

WARRANTY (USA)

Should your LG Dual Fuel Range fail due to a defect in materials or workmanship under normal home use, during the warranty period set forth below, LG will at its option repair or replace the product. This limited warranty is valid only to the original retail purchaser of the product and applies only when purchased and used within the United States including U.S. Territories. Proof of original retail purchase is required to obtain warranty service under this limited warranty.

Warranty Period	Scope of Warranty	HOW SERVICE IS HANDLED
One (1) year from date of original retail purchase	Parts and Labor	LG will provide parts and labor to repair or replace defective parts.

- Replacement products and parts are warranted for the remaining portion of the original warranty period or ninety (90) days, whichever is greater.
- Replacement products and parts may be new or remanufactured.

THIS WARRANTY IS IN LIEU OF ANY OTHER WARRANTY, EXPRESS OR IMPLIED, INCLUDING WITHOUT LIMITATION, ANY WARRANTY OF MERCHANTABILITY OR FITNESS FOR A PARTICULAR PURPOSE. TO THE EXTENT ANY IMPLIED WARRANTY IS REQUIRED BY LAW, IT IS LIMITED IN DURATION TO THE EXPRESS WARRANTY PERIOD ABOVE. NEITHER THE MANUFACTURER NOR ITS U.S. DISTRIBUTOR SHALL BE LIABLE FOR ANY INCIDENTAL, CONSEQUENTIAL, INDIRECT, SPECIAL, OR PUNITIVE DAMAGES OF ANY NATURE, INCLUDING WITHOUT LIMITATION, LOST REVENUES OR PROFITS, OR ANY OTHER DAMAGE WHETHER BASED IN CONTRACT, TORT, OR OTHERWISE.

Some states do not allow the exclusion or limitation of incidental or consequential damages or limitations on how long an implied warranty lasts, so the above exclusion or limitation may not apply to you. This warranty gives you specific legal rights and you may also have other rights that vary from state to state.

THIS LIMITED WARRANTY DOES NOT COVER:



- Service trips to deliver, pick up, or install or repair the product; instruction to the customer on operation of the product; repair or replacement of fuses or correction of wiring or plumbing, or correction of unauthorized repairs/installation.
- Failure of the product to perform during power failures and interruptions or inadequate electrical service.
- Damage caused by leaky or broken water pipes, frozen water pipes, restricted drain lines, inadequate or interrupted water supply or inadequate supply of air.
- Damage resulting from operating the Product in a corrosive atmosphere or contrary to the instructions outlined in the Product's owner's manual.
- Damage to the Product caused by accidents, pests and vermin, lightning, wind, fire, floods, or acts of God.
- Damage or failure caused by unauthorized modification or alteration, or if it is used for other than the intended purpose, or any water leakage where the unit was not properly installed.
- Damage or failure caused by incorrect electrical current, voltage, or plumbing codes, commercial or industrial use, or use of accessories, components, or consumable cleaning products that are not approved by LG.
- Damage caused by transportation and handling, including scratches, dents, chips, and/or other damage to the finish of your product, unless such damage results from defects in materials or workmanship and is reported within one (1) week of delivery.
- Damage or missing items to any display, open box, discounted, or refurbished Product.
- Products with original serial numbers that have been removed, altered, or cannot be readily determined. Model and Serial numbers, along with original retail sales receipt, are required for warranty validation.
- Increases in utility costs and additional utility expenses.
- Repairs when your Product is used in other than normal and usual household use (e.g. commercial use, in offices and recreational facilities) or contrary to the instructions outlined in the Product's owner's manual.
- Costs associated with removal of your Product from your home for repairs.

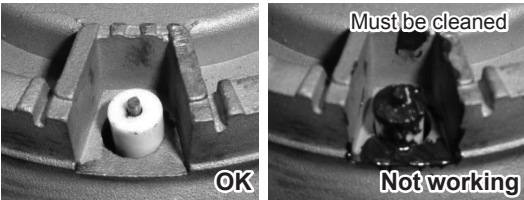
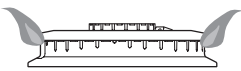
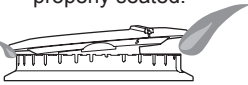
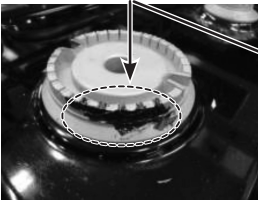
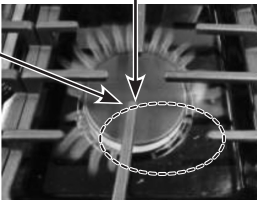
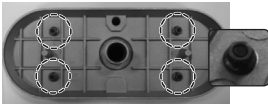
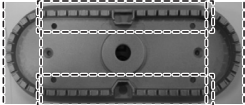
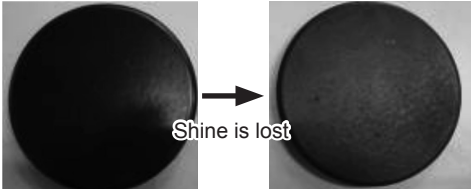

62 WARRANTY

- The removal and reinstallation of the Product if it is installed in an inaccessible location or is not installed in accordance with published installation instructions, including LG's owner's and installation manuals.
- Damage resulting from misuse, abuse, improper installation, repair, or maintenance. Improper repair includes use of parts not approved or specified by LG.

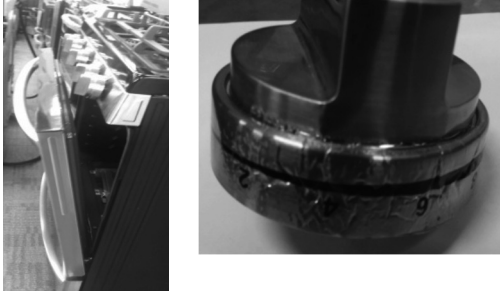
The following circumstances are not covered under the warranty:

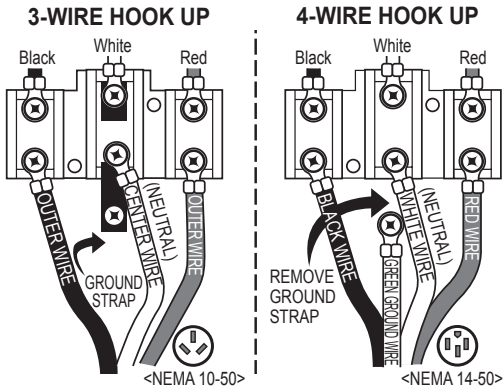
Problem	Cause	Prevention
<ul style="list-style-type: none"> • Burners do not light 	<p>Clogged or dirty burner ports or electrodes will not allow the burner to operate properly</p> 	<ul style="list-style-type: none"> • Check and clean the gas electrode.
<ul style="list-style-type: none"> • Uneven flame 	<ol style="list-style-type: none"> 1. Improper burner cap installation <div style="display: flex; justify-content: space-around; align-items: flex-start;"> <div style="text-align: center;"> <p>Burner cap is properly seated.</p>  </div> <div style="text-align: center;"> <p>Burner cap is NOT properly seated.</p>  </div> </div> 2. Burner ports clogged by food residue <div style="display: flex; justify-content: space-around; align-items: flex-start;"> <div style="text-align: center;"> <p>Ports blocked by dirt</p>  </div> <div style="text-align: center;"> <p>Flames uneven</p>  </div> </div> <p>* Oval burner</p> <div style="display: flex; justify-content: space-around; align-items: flex-start;"> <div style="text-align: center;"> <p>To clean: Release 4 nuts</p>  </div> <div style="text-align: center;"> <p>Clean ports with toothbrush</p>  </div> </div>	<ul style="list-style-type: none"> • Check installation of burner head and cap • Hardened residue should be removed using a toothbrush. <ul style="list-style-type: none"> • Oval burner <ol style="list-style-type: none"> 1) Release 4 nuts 2) Clean residue using toothbrush
<ul style="list-style-type: none"> • Burner cap color change and lost shine 	<ol style="list-style-type: none"> 1. Scratching 2. Use of detergent or abrasive cleansers 	<ul style="list-style-type: none"> • Do not use steel wool or abrasive cleansers to clean. • To remove burnt-on food, soak the burner heads in hot water for 20–30 minutes. (Do not use detergent)

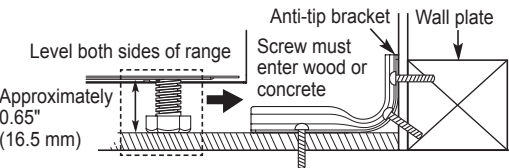
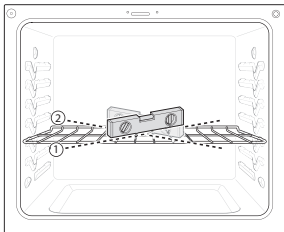
Problem	Cause	Prevention
<ul style="list-style-type: none"> Knobs melt 	<p>Improper usage</p> 	<ul style="list-style-type: none"> Do not leave door at stop position during Broil/Bake mode or right after cooking.
<ul style="list-style-type: none"> Oven or racks are stained after using aluminum foil 	<p>Aluminum foil has melted in the oven</p> 	<ul style="list-style-type: none"> Never cover the oven bottom or cover an entire rack with materials such as aluminum foil. If the foil has already melted onto the oven, it will not affect the performance of the oven.
<ul style="list-style-type: none"> Unit has no power 	<ol style="list-style-type: none"> House power turned off (power supply) Tripped breaker The power cord is not installed properly. 	<ul style="list-style-type: none"> Check power at main board before calling for service. Match power cord type and outlet type Properly install the power cord

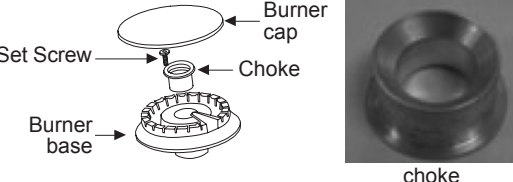
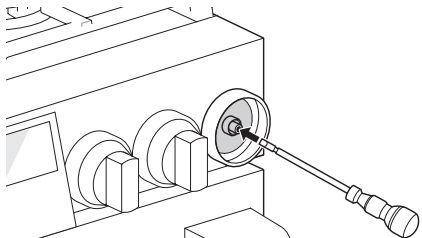
Problem	Cause	Prevention
<ul style="list-style-type: none"> • Surface is not level • Oven is tipping 	<ol style="list-style-type: none"> 1. Range not leveled 2. Anti-tip device not installed correctly  	<ul style="list-style-type: none"> • Check with installer first
<ul style="list-style-type: none"> • Flames too big on converted cooktop (NP → LP) 	<p>The installer missed part of the conversion. (Check 3 parts: regulator, cooktop valve, broil/bake valve).</p> 	<ul style="list-style-type: none"> • Check with installer first • Refer to installation manual
	<p>18.5 K burner needs choke.</p> 	<ul style="list-style-type: none"> • Check with installer first • Refer to installation manual
<ul style="list-style-type: none"> • Flame is too small or too large 	<ol style="list-style-type: none"> 1. Variable gas pressure 2. Installer did not check 	<ul style="list-style-type: none"> • Check with installer first

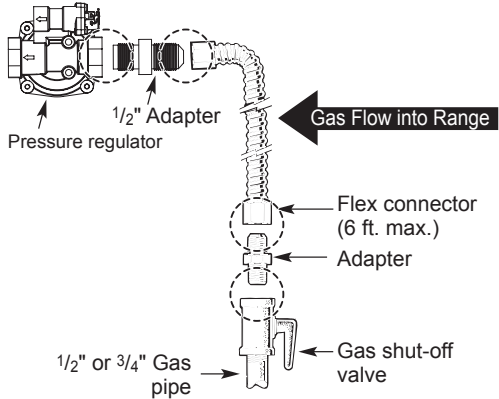
Problem	Cause	Prevention
<ul style="list-style-type: none"> Gas smell 	<p>Improper connection</p> <p>Flexible Connector Hookup</p>  <p>The diagram illustrates a gas line assembly. On the left, a pressure regulator is connected to a 1/2" adapter. This adapter is connected to a flexible connector, which is labeled as having a maximum length of 6 feet. The flexible connector is further connected to another adapter, which is then connected to a gas shut-off valve. The shut-off valve is connected to a 1/2" or 3/4" gas pipe. An arrow labeled "Gas Flow into Range" points from the right towards the flexible connector.</p>	<ul style="list-style-type: none"> Check with installer first

The cost of repair or replacement under these excluded circumstances shall be borne by the consumer.

OBTAIN WARRANTY SERVICE AND ADDITIONAL INFORMATION

If you do not have access to the internet and you need assistance using your product or you would like to schedule service, you may contact LG Electronics at the number below.

For assistance or service, call 1-800-984-6306.

If you need further assistance, you can write to LG with any questions or concerns at the address below:

LG Electronics, 201 James Record Road, Huntsville, Alabama 35813

For additional product information, visit our website at <http://www.lg.com>