

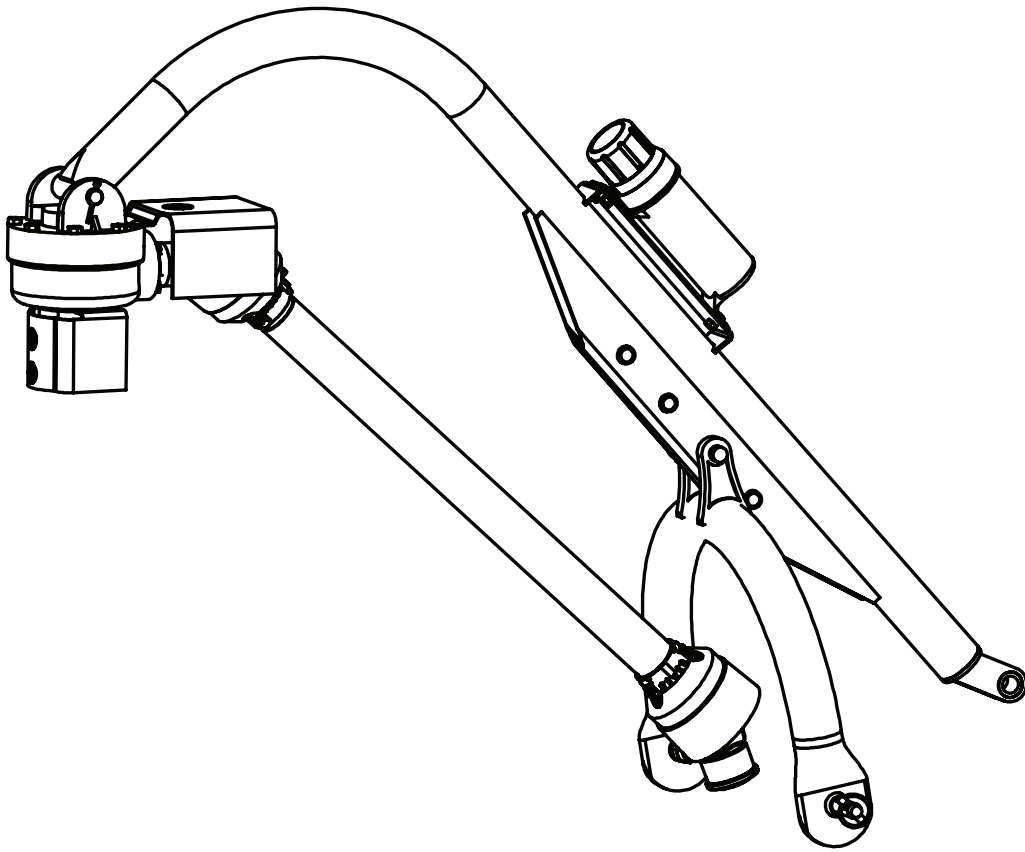

DIRTY HAND<sup>®</sup>  
TOOLS

# Post Hole Diggers

• Compact • Standard • Heavy Duty



MODEL 90 / MODEL 100 / MODEL 110  
# 100623                      # 100498                      # 100624

## Operation Manual



This safety alert symbol identifies important safety messages in this manual. Failure to follow this important safety information may result in serious injury or death.

Part # 100625 Rev E

*Designed & Engineered in Colorado, USA*



*Assembled with Foreign & Domestic Components*

For Service or Questions

**Call 1-877-487-8275**

**720-287-5182**

**[www.dirtyhandtools.com](http://www.dirtyhandtools.com)**

Dirty Hand Tools® is a brand of



**FrictionlessWorld**

1100 W 120th Ave, Suite 600  
Westminster, CO 80234 • 720-287-5182

**Register warranty online within 30 days of purchase!**

**[dirtyhandtools.com](http://dirtyhandtools.com)**

In the toolbar, click “Support” then “Warranty”

# Table of Contents

<b>Important Safety Information</b> .....	4
Intended Use .....	4
Personal Protective Equipment .....	4
General Safety .....	5
Safety Decals .....	7
<b>Assembly Instructions</b> .....	8
<b>Operating Instructions</b> .....	10
<b>Maintenance</b> .....	11
<b>Post Hole Digger Parts List</b> .....	12
<b>Auger Parts List</b> .....	13
<b>Warranty &amp; Specifications</b> .....	Back Cover

# Important Safety Information



WARNING

**WARNING:** Read and thoroughly understand all instructions and safety information before assembling or operating this post hole digger. Failure to do so may cause serious injury or death. Do not allow anyone to operate this post hole digger who has not read this manual. As with all power equipment, a post hole digger can be dangerous if assembled or used improperly. Do not operate if you have doubts or questions concerning safe operation.

Call our customer service department at **720-287-5182**, **1-877-487-8275**, or visit [www.dirtyhandtools.com](http://www.dirtyhandtools.com) if you have any questions or concerns about the safe operation of this equipment.



DANGER

## INTENDED USE

Do Not Use the post hole digger for any purpose other than digging post holes in soil when connected to a 3-point linkage system and power take off of a tractor. Any other use is unauthorized and may result in serious injury or death.

## PERSONAL PROTECTIVE EQUIPMENT

When operating this post hole digger it is essential that you wear safety gear including goggles or safety glasses, steel toed shoes and tight fitting gloves (no loose cuffs or draw strings).



CAUTION

**Do Not** wear loose clothing or jewelry that can be caught by moving parts of the post hole digger including the auger and driveline. Keep clothing and hair away from all moving parts when operating.



DANGER

## GENERAL SAFETY

Failure to follow warnings, cautions, assembly and operation instructions in the Operation Manual may result in serious injury or death.

### Read the Operation Manual before operation.

- **Do not** permit others that have not read and understood the complete Operation Manual to operate this equipment.
- Keep all people and pets a minimum of 10 feet away from the work area when operating this post hole digger.
- **Do not** operate the post hole digger when under the influence of alcohol, drugs or medication.
- **Do not** allow a person who is tired or otherwise impaired or not completely alert to operate the post hole digger
- **Always** check with authorities for underground utilities before digging holes. Serious injury or death could result from contact with gas or electric lines.
- **Read the tractor's operation manual** concerning the proper attachment and use of 3-point equipment and safety.
- **Always** make sure that all safety shields are in place and securely fastened. Do not operate if any shields are missing.
- **Make sure** that the auger point and cutting edges are intact and in good working condition prior to use.



DANGER

**ALWAYS OPERATE THIS POST HOLE DIGGER FROM THE TRACTOR SEAT.** Only one person should operate the digger.

**DO NOT ATTACH THE POST HOLE DIGGER TO THE TRACTOR WITH THE ENGINE RUNNING.**

**DO NOT OPERATE THE POST HOLE DIGGER WITH ANYONE IN CONTACT WITH ANY PART OF THE IMPLEMENT, PTO DRIVELINE OR AUGER.**

**SERIOUS INJURY CAN RESULT FROM ENTANGLEMENT WITH MOVING PARTS.**

## Important Safety Information



DANGER

- **Make sure** that the tractor brake is set before deploying the post hole digger.
- **Do not** manually deploy the auger.
- **Do not** manually position or force the auger into the ground.
- **Turn off tractor engine** before leaving the seat of the tractor.
- **Do not** move the tractor with the power take off in the ON position.
- **Do not** exceed the 540 RPM PTO operating speed.



DANGER

- **NEVER OPERATE THE POST HOLE DIGGER WITH THE AUGER MORE THAN 6 INCHES ABOVE GROUND LEVEL.** Operating the post hole digger in an elevated position may cause the PTO driveline u-joints to bind resulting in equipment damage and operator injury.
- **ALWAYS** turn off the post hole digger if a rock or other obstacle is encountered during operation to prevent damage to the gear box and possible operator injury. Shear bolts could become welded to the input shaft of the drive shaft if left running after being sheared.



DANGER

- **ONLY PERFORM MAINTENANCE** such as lubrication, adjustments and repairs with the tractor engine turned off, the PTO disengaged and the auger point resting at ground level.
- **ALWAYS** replace shear bolts with the correct shear bolt size and grade (SAE Grade 5). Never use a shear bolt that is longer or larger than what is specified in the operation manual for that post hole digger model.

# Important Safety Information

## SAFETY DECALS

Make sure all safety warning decals are attached and in readable condition. Replace missing or defaced decals. Contact Dirty Hand Tools at 1-877-487-8275 for replacement decals.

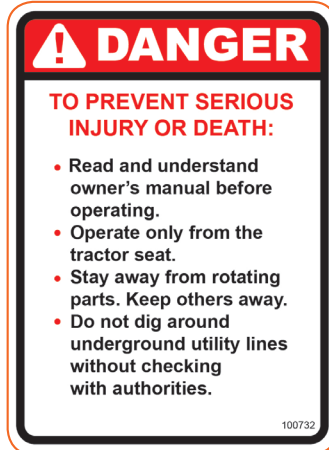

Location: PTO drive shaft shield



Location: Top end of auger tube

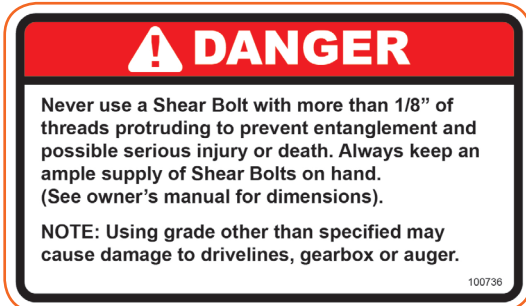

Location: Gear box shield



Location: Boom, hitch end, right side

Location: PTO drive shaft inside shield



Location: PTO drive shaft shield



Location: Boom, gear box end, left side



Location: Gear box case



# Assembly Instructions

## Step 1: Fill the gear box with lubricant.

The gear box is shipped without lubricant. Fill the top hole with EP90 lubricant or equivalent. The gear box holds 25 fluid oz. (0.7 liters). Fill to the bottom of the plug on the side. **Do not overfill as this can cause damage to the seals. Check the oil level every 50 hours of operation.**

## Step 2: Attach the boom.

Attach the boom to the top link mounting bracket on the tractor using a top link pin and a lynch pin through the hole on the bottom of the boom. Top link pin and lynch pin are not provided.

## Step 3: Connect the A frame.

Connect the A frame to the tractor's 3-point lift arms using draw pin assembly provided, with nut and lock washer. Attach the A frame to the boom after selecting the desired hole for adjustment using the A frame pin and a lynch pin. The size of your tractor and auger will determine which hole will work best.

## Step 4: Attach the gear box.

Attach the gear box to the boom using the gear box draw pin provided with the gear box and secure with cotter pins provided. The input shaft shield and the output shaft shield are already attached to the gear box.

## Step 5: Attach the auger.

Attach the auger to the output shaft on the bottom of the gear box using 1/2 in. hex cap screws, 1/2 in. lock washers and 1/2 in. hex nuts provided.

## Step 6: Attach the driveline.

Attach the driveline to the gear box input shaft using 5/16 in. hex cap screw, 5/16 in. lock washer and 5/16 in. hex nut. For Model 110, attach the driveline to the gear box input shaft using 3/8 in. hex cap screw, 3/8 in. lock washer and 3/8 in. hex nut. Insert 1/4 in. x 3/8 in. set screw into the hole on the yoke that aligns with the 3/16 in. groove on the gear box input shaft.



ATTENTION

The 5/16 in. hex cap screw (3/8 in. for Model 110) provides shear protection. Only use a Grade 5 3 in. bolt to avoid damage to the gear box or auger.

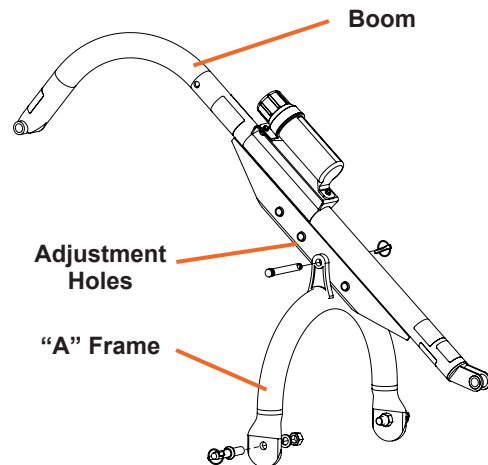

Figure A

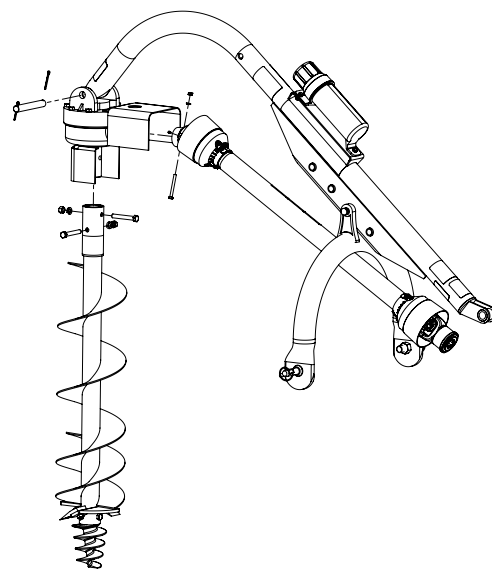

Figure B



The universal joint should be greased with chassis lube every week. Grease the sliding drive shaft members with moly grease at the beginning of each season of use. All post hole diggers are equipped with quick release universal joints on the PTO end for a 1-3/8 in. splined shaft.

### **Step 7: Attach the tractor end of driveline.**

Attach the tractor end of the driveline to the tractor PTO shaft. Push the spring loaded pin in the splined yoke and slip it onto the splined PTO shaft of the tractor. Release the pin and push until it locks securely.

Note: it may be necessary to obtain a 1-1/8 in. to 1-3/8 in. sleeve spline adapter if the tractor has a 1-1/8 in. spline shaft.

### **Step 8: Check tightness of all bolts and nuts.**

Stabilizers should be kept tight to avoid side sway of the post hole digger.

See Figure A for reference in assembling the post hole digger and attachment to the tractor.

Note: The boom angle can be adjusted on the tractor for proper hole digging and ground clearance by moving the A frame to a different mounting hole.

Note: If the 7/8 in. diameter pull pins are too small for the holes in the lift arms, bushings should be used to obtain the correct fit for operation.

# Operating Instructions



## WARNING

**WARNING:** Read and thoroughly understand all instructions and safety information before assembling or operating this post hole digger. Failure to do so may cause serious injury or death.

### Step 1: Lower auger.

After attaching the post hole digger to the tractor, **before engaging the power**, slowly lower the auger to the ground at the desired angle for hole digging.

### Step 2: Engage PTO.

Engage the power take off and start digging at a slow speed lowering the auger slowly as the hole is dug.

### Step 3: Increase speed.

Increase the speed as the auger goes deeper into the ground. The type of soil will determine the proper auger speed. A very hard or compacted soil may require operation at varying speeds to be the most efficient in digging.



## CAUTION

## NEVER ALLOW THE TRACTOR'S ENGINE TO RUN WHILE MANUALLY DISLODGING AN OBSTACLE.

If a rock or other obstacle is encountered that is too large for the auger to displace the post hole digger will begin to vibrate. Slowly withdraw the auger from the hole completely. Turn off the tractor's power and remove the obstacle manually. Slowly lower the auger into the hole and engage the power to complete digging the hole.

### Step 4: Removing the auger.

After the desired hole depth has been reached, spin the auger at a high speed to clear the hole of soil. Reduce the speed before withdrawing the auger from the hole.

### Step 5: Disengage PTO.

Disengage the power take off after withdrawing the auger from the hole and move to the next desired hole location.



WARNING

**ALWAYS PERFORM MAINTENANCE OPERATIONS WITH THE TRACTOR'S ENGINE POWERED OFF, PTO DISENGAGED, AND THE AUGER TIP RESTING ON THE GROUND.**

Before operation check all safety shields. Replace shields that are worn or broken before operating the post hole digger.

When the self-sharpening points on the auger show excessive wear it is important to replace them.

Check the oil level after every 50 hours of operation. Use EP90 lubricant or equivalent and fill to oil level plug. Always use the same replacement lubricant type.

Universal joints should be greased with chassis lube once a week during operating season. Grease the sliding drive shaft members with moly grease at the beginning of each season.

To remove the auger from the gear box output shaft, remove the two 1/2 in. x 3 in. hex cap screws.

To remove the drive shaft from the gear box input shaft, remove the shear pin bolt and 1/4 in. set screw.

# Post Hole Digger Parts List

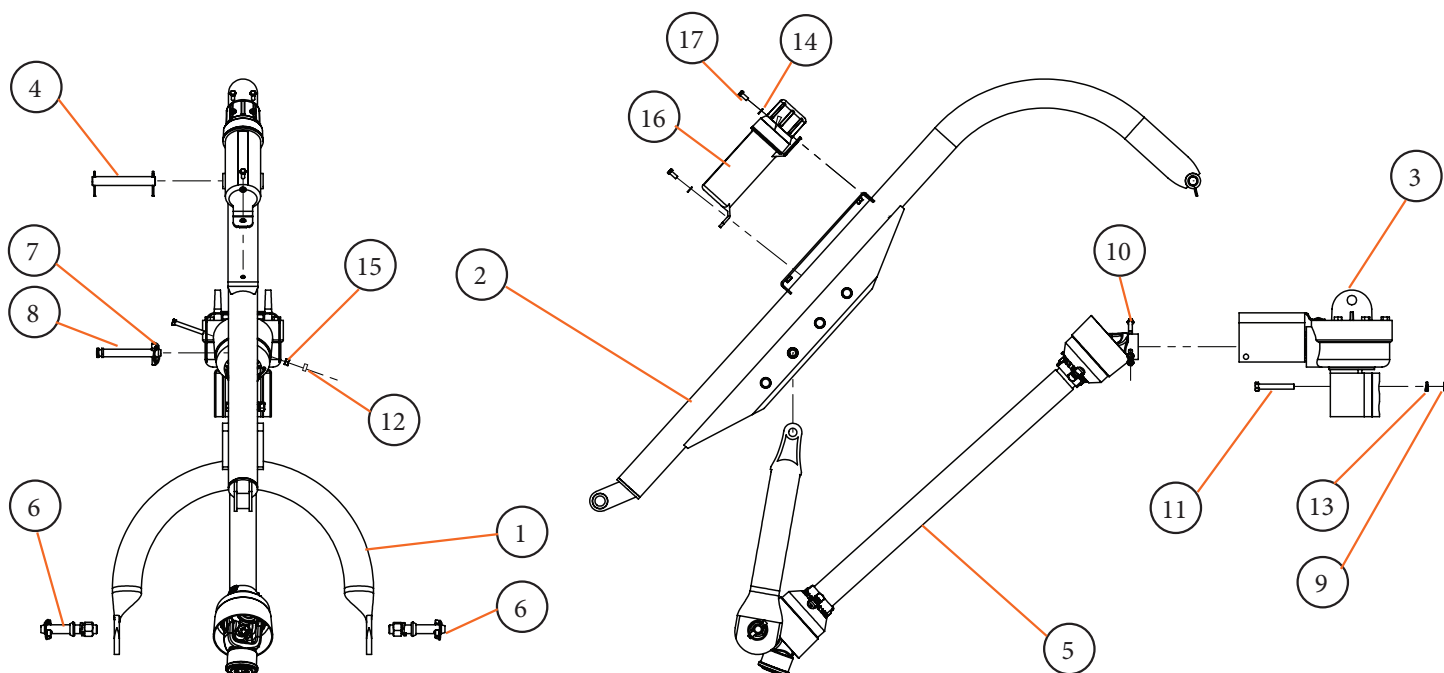

Item #	Part #	Description	Qty
1	100551	Tube, 3 Pt A Frame Round, Model 100	1
	101197	Tube, 3 Pt A Frame Round, Model 90	1
	101314	Tube, 3 Pt A Frame Round, Model 110	1
2	100549	Boom, Model 100	1
	101203	Boom, Model 90	1
	101309	Boom, Model 110	1
3	100643	Gearbox Covered Assembly	1
	101302	Gearbox Covered Assembly, Model 110	1
4	100607	Gearbox Draw Pin	1
	101317	Gearbox Draw Pin, Model 110	1
5	100603	PTO Driveline Assembly	1
	106250	PTO Driveline Assembly, Model 110	1
6	102120	Draw Pin Assembly, 7/8 in. - 14 x 1-5/8 in., G8	2
7	102351	Lynch Pin, 3/8 in. x 1-3/4 in.	3
8	102150	Top Link Pin, 3/4 in. x 4-3/4 in., G8	1
9	100575	Hex Nut 1/2 in. - 13	2
10	100609	Hex Bolt, 5/16 in. - 18 x 3 in, G5	1
11	100574	Hex Bolt, 1/2 in. - 13 x 3-1/2 in., G5	2
12	100610	Hex Nut, 3/8 in. - 6, G5	1
13	100576	Lock Washer, 1/2 in.	2
14	100130	Flat Washer, M8	3
15	100611	Lock Washer, 3/8 in.	1
16	100084	Manual Cannister	1
17	100125	Hex Bolt, M8 x 1.25 x 20MM, G8.8	3

# Auger Parts List

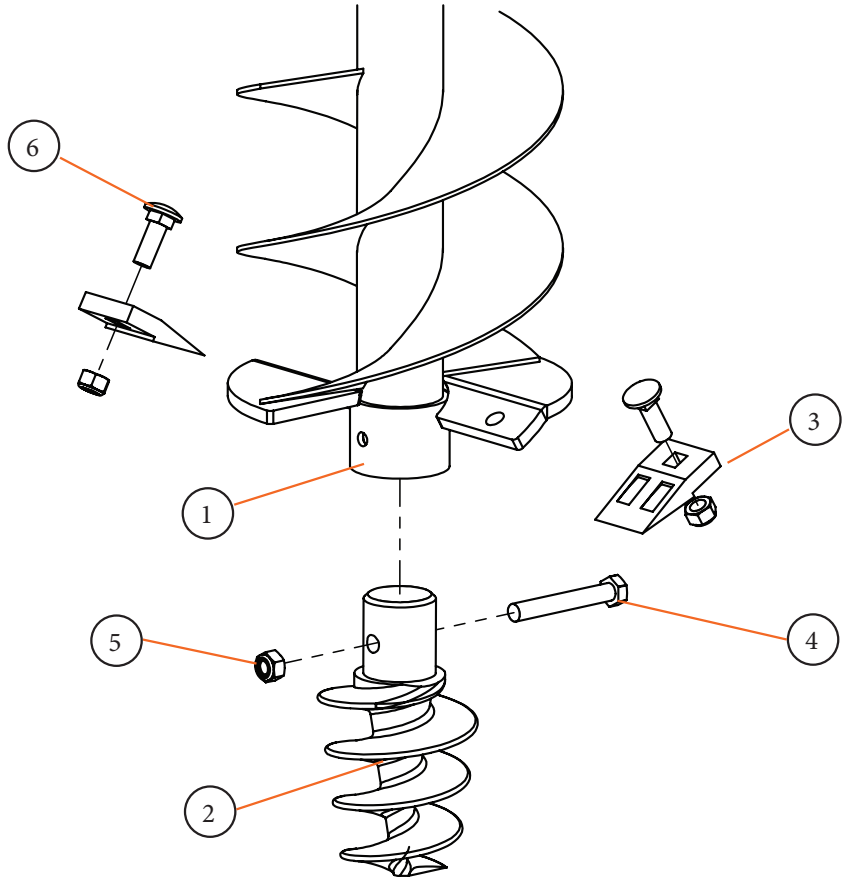
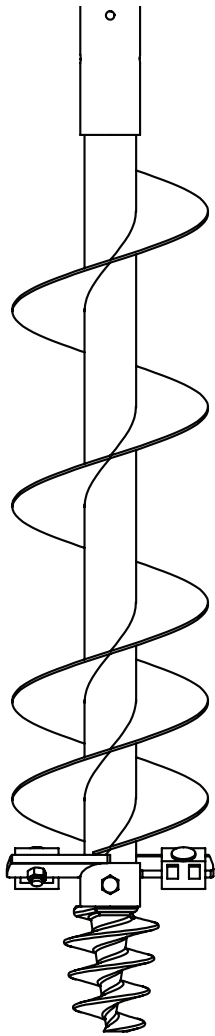

Auger Diameter	Number of Cutting Edges
6 in.	2
9 in.	2
12 in.	4
18 in.	4
24 in.	6

Item #	Part #	Description	Qty
1	100618	Auger Flutes	1
2	100620	Auger Tip	1
3	100619	Auger Cutting Tooth	2
4	100574	Hex Bolt, 1/2 in. - 13 x 3-1/2 in., G5	1
5	100059	Hex Nut, M12 x 1.75 in., G8.8	1
6	100581	Carriage Bolt, 1/2 in. - 13 x 2 in., G5	1



# Notes

---

---

---

---

---

---

---

---

---

---

---

---

---

---

---

---

---

---

---

---

---

---

---

---

---

---

---

---

---

---



# Warranty & Specifications

## IMPORTANT NOTICE

We, the manufacturer, reserve the right to change the product and/or specifications in this manual without notification. The manual is for information usage only and the pictures and drawings depicted herein are for reference only.

## Warranty Repair and Service

Do not return this product to the store for warranty issues or repair. Call our customer service department at **720-287-5182, 1-877-487-8275**, or visit [www.dirtyhandtools.com](http://www.dirtyhandtools.com) for the location of the nearest service center.

Record the information below for future reference.

Model No. \_\_\_\_\_

Serial No. \_\_\_\_\_

Date of Purchase \_\_\_\_\_

Place of Purchase \_\_\_\_\_

Register warranty online within 30 days of purchase!

[dirtyhandtools.com](http://dirtyhandtools.com)

In the toolbar, click "Support" then "Warranty"

## Specifications

SKU/Part No.	100623	100498	100624
Model #	90	100	110
Description	Compact	Standard Duty	Heavy Duty
Tractor Category	Subcompact and Cat 0	Cat 1 and Cat 2	Cat 1 and Cat 2
Gear Box	3:1 Ratio, 2 in. output shaft	3:1 Ratio, 2 in. output shaft	3:1 Ratio, 2 in. output shaft
Driveline	Yoke fits 6-spline PTO	Yoke fits 6-spline PTO	Yoke fits 6-spline PTO
Auger Diameter	6 in., 9 in., 12 in.	6 in., 9 in., 12 in.	6 in., 9 in., 12 in.
Boom	2-7/8 in. O.D. tubing	2-7/8 in. O.D. tubing	3-1/4 in. O.D. tubing
A-Frame	2-7/8 in. O.D. tubing	2-7/8 in. O.D. tubing	2-7/8 in. O.D. tubing
Safety Shields	On driveline, gear box "U" joint and gear box output shaft		
Shear Bolt	Replaceable, on input shaft, to protect driveline, auger and gears		
Options	6 in. auger	6 in. auger	6 in. auger
	9 in. auger	9 in. auger	9 in. auger
	12 in. auger	12 in. auger	12 in. auger
	-	-	18 in. auger
	-	-	24 in. auger
Item / Shipping Weight	202 / 222 lbs.	208 / 228 lbs.	269 / 289 lbs.
Warranty	2 Year Limited Warranty	2 Year Limited Warranty	2 Year Limited Warranty
UPC	856206004157	856206004102	856206004164

Dirty Hand Tools® is a brand of



**FrictionlessWorld**

1100 W 120th Ave., Suite 600  
Westminster, CO 80234 • 720-287-5182

For Service or Questions

Call 1-877-487-8275

**720-287-5182**

[www.dirtyhandtools.com](http://www.dirtyhandtools.com)