

DEEBOT™ M88

EN

Instruction Manual



Note: This Instruction Manual applies to units purchased in North America only.

Live Smart. Enjoy Life.

Congratulations on the purchase of your ECOVACS ROBOTICS DEEBOT! We hope it brings you many years of satisfaction. We trust the purchase of your new robot will help keep your home clean and provide you with more quality time to do other things.

Before you go any further, please register your product on the ECOVACS ROBOTICS website at www.ecovacsrobotics.com/registration/. We also suggest you record your model number, serial number, date of purchase and attach your receipt to this page for safekeeping.

MODEL # _____

SERIAL # _____

DATE OF PURCHASE ____/____/____

Should you have any problems programming the robot or getting your robot to function properly, please call us before contacting or returning it to the place of purchase. Call toll free number 1-844-ECOVACS (1-844-326-8227) or 1-330-994-1760 from outside the United States of America and Canada for assistance.

Thank you for choosing DEEBOT!

Contents

1. Important Safety Instructions	2
2. Package Contents and Technical Specifications	4
2.1 Package Contents	4
2.2 Specifications	4
2.3 Product Diagram	5
3. Operating and Programming	7
3.1 Notes Before Cleaning	7
3.2 Quick Start	8
3.3 Cleaning Pattern and Cleaning Mode Selection	11
3.4 Programming the Robot	15
3.5 Choosing a Suction Option	16
3.6 Optional Advanced Wet/Dry Mopping System	17
3.7 Alarm Indicator Light and Sounds	20
4. Maintenance	21
4.1 Dust Bin and Filters	21
4.2 Advanced Wet/Dry Cleaning Cloth, Advanced Wet/Dry Reservoir	22
4.3 Main Brush, Direct Suction Option and Side Brushes	23
4.4 Other Components	24
5. Troubleshooting	25

1. Important Safety Instructions

When using an electrical appliance, basic precautions should always be followed, including the following:

READ ALL INSTRUCTIONS BEFORE USING THIS APPLIANCE.

SAVE THESE INSTRUCTIONS

1. This Appliance is not intended to be used by children under 8 or anyone lacking knowledge on proper use. Supervision may be necessary. Do not allow children to sit on or play with the Appliance.
2. Clear the area to be cleaned. Remove power cords and small objects from the floor that could entangle the Appliance. Tuck rug fringe under the rug base, and lift items such as curtains and tablecloths off the floor.
3. If there is a drop off in the cleaning area due to a step or stairs, you should operate the Appliance to ensure that it can detect the step without falling over the edge. It may become necessary to place a physical barrier at the edge to keep the unit from falling. Make sure the physical barrier is not a trip hazard.
4. Only use as described in this manual. Only use attachments recommended or sold by the manufacturer.
5. Please make sure your power supply voltage matches the power voltage marked on the Charging Dock.
6. For INDOOR household use ONLY. Do not use the Appliance in outdoor, commercial or industrial environments.
7. Use only the original rechargeable battery and Charging Dock provided with the Appliance from the manufacturer. Non-rechargeable batteries are prohibited. For battery information, please refer to Specifications section.
8. Do not use without dust bin and/or filters in place.
9. Do not operate the Appliance in an area where there are lit candles or fragile objects.
10. Do not use in extremely hot or cold environments (below -5°C/23°F or above 40°C/104°F).
11. Keep hair, loose clothing, fingers, and all parts of body away from any openings and moving parts.
12. Do not operate the Appliance in a room where an infant or child is sleeping.
13. Do not use Appliance on wet surfaces or surfaces with standing water.
14. Do not allow the Appliance to pick up large objects like stones, large pieces of paper or any item that may clog the Appliance.
15. Do not use Appliance to pick up flammable or combustible materials such as gasoline, printer or copier toner, or use in areas where they may be present.
16. Do not use Appliance to pick up anything that is burning or smoking, such as cigarettes, matches, hot ashes, or anything that could cause a fire.
17. Do not put objects into the suction intake. Do not use if the suction intake is blocked. Keep the intake clear of dust, lint, hair, or anything that may reduce air flow.
18. Take care not to damage the power cord. Do not pull on or carry the Appliance or Charging Dock by the power cord, use the power cord as a handle, close a door on the power cord, or pull power cord around sharp edges or corners. Do not run Appliance over the power cord. Keep power cord away from hot surfaces.
19. If the power cord is damaged, it must be replaced by the manufacturer or its service agent in order to avoid a hazard.
20. Do not use the Charging Dock if it is damaged.
21. Do not use with a damaged power cord or receptacle. Do not use the Appliance or Charging Dock if it is not working properly, has been dropped, damaged, left outdoors, or come in contact with water. It must be repaired by the manufacturer or its service agent in order to avoid a hazard.

1. Important Safety Instructions

22. Turn OFF the power switch before cleaning or maintaining the Appliance.
23. The plug must be removed from the receptacle before cleaning or maintaining the Charging Dock.
24. Remove the Appliance from the Charging Dock, and turn OFF the power switch to the Appliance before removing the battery for disposal of the Appliance.
25. The battery must be removed and discarded according to local laws and regulations before disposal of the Appliance.
26. Please dispose of used batteries according to local laws and regulations.
27. Do not incinerate the Appliance even if it is severely damaged. The batteries can explode in a fire.
28. When not using the Charging Dock for a long period of time, please unplug it.
29. The Appliance must be used in accordance with the directions in this Instruction Manual. ECOVACS ROBOTICS cannot be held liable or responsible for any damages or injuries caused by improper use.

Changes or modifications not expressly approved by the party responsible for compliance could void the user's authority to operate the equipment.

This equipment has been tested and found to comply with the limits for a Class B digital device, pursuant to part 15 of the FCC Rules. These limits are designed to provide reasonable protection against harmful interference in a residential installation. This equipment generates uses and can radiate radio frequency energy and, if not installed and used in accordance with the instructions, may cause harmful interference to radio communications. However, there is no guarantee that interference will not occur in a particular installation. If this equipment does cause harmful interference to radio or television reception, which can be determined by turning the equipment off and on, the user is encouraged to try to correct the interference by one or more of the following measures:

- Reorient or relocate the receiving antenna.
- Increase the separation between the equipment and receiver.
- Connect the equipment into an outlet on a circuit different from that to which the receiver is connected.
- Consult the dealer or an experienced radio/TV technician for help.

To satisfy FCC / IC RF exposure requirements, a separation distance of 20 cm or more should be maintained between the antenna of this device and persons during device operation.

To ensure compliance, operations at closer than this distance is not recommended.

2. Package Contents and Technical Specifications

2.1 Package Contents

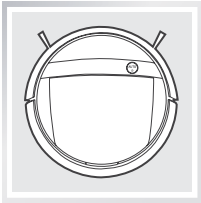

Robot

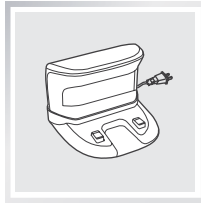

Charging Dock

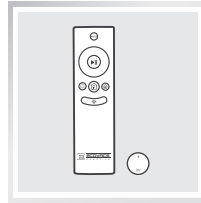

Remote Control with
Button Cell Battery



Instruction Manual

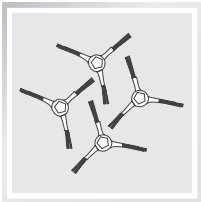

(4) Side Brushes

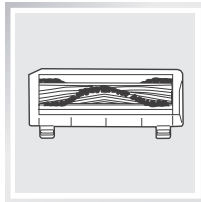

Main Brush Option
(pre-installed)

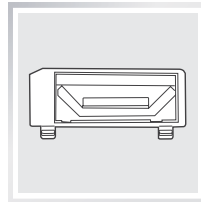

Direct Suction Option

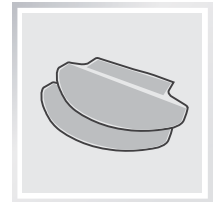

(2) Advanced Wet/Dry
Cleaning Cloths

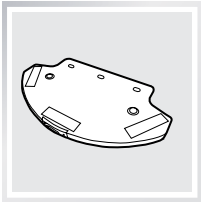

Advanced Wet/Dry
Reservoir

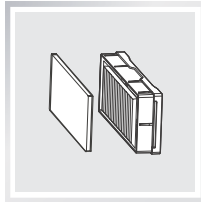

Replacement High
Efficiency Filter+
Sponge Filter

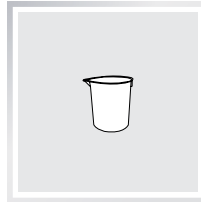

Measuring Cup



Reservoir Cleaning
Solution

2.2 Specifications

Model	DM88		
Working Voltage	12V DC	Rated Power	30W
Charging Dock Model	CH1465A		
Rated Input Voltage	100-240V AC	Rated Output Voltage	20V DC
Rated Output Current	1A	Rated Power	25W
Remote Control Model	RC1521	Input Voltage	3V DC
Battery	Ni-MH SC 3000mAh		

* Technical and design specifications may be changed in the course of continuous product improvement.

2. Package Contents and Technical Specifications

2.3 Product Diagram

Robot

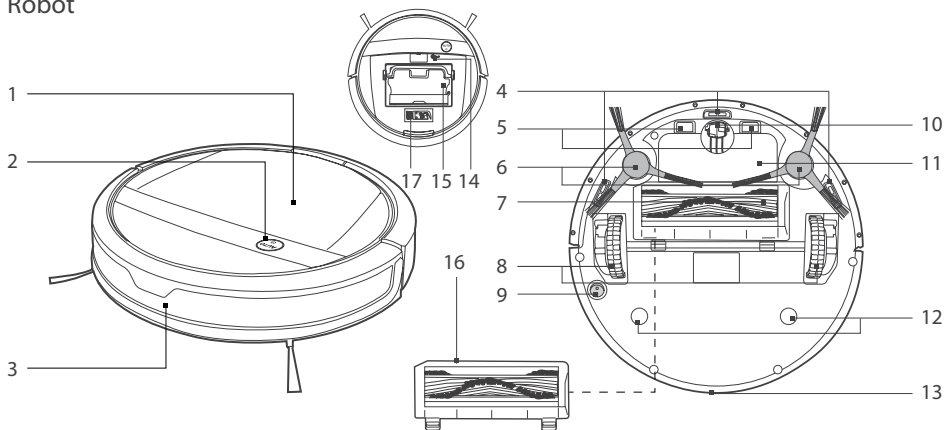

- | | | |
|---------------------------|--|---|
| 1. Top Cover | 8. Driving Wheels | 14. Reset Button
(For Customer Service Only) |
| 2. Control Panel | 9. Bottom Power Switch | 15. Dust Bin |
| 3. Anti-Collision Sensors | 10. Universal Wheel | 16. Main Brush Cover |
| 4. Anti-Drop Sensors | 11. Battery Cover | 17. Multi-Function Cleaning Tool |
| 5. Charging Contacts | 12. Advanced Wet/Dry Reservoir Slots | |
| 6. Side Brushes | 13. Infrared Receiver for Remote Control | |
| 7. Main Brush Option | | |

Control Panel



- | |
|--|
| 1. AUTO Mode Button
(One-touch START/PAUSE) |
| 2. Wi-Fi Indicator Light |

Charging Dock

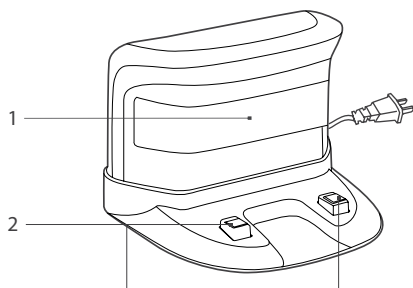

- | |
|------------------------------|
| 1. Infrared Signal Generator |
| 2. Charging Dock Pins |

2. Package Contents and Technical Specifications

Remote Control

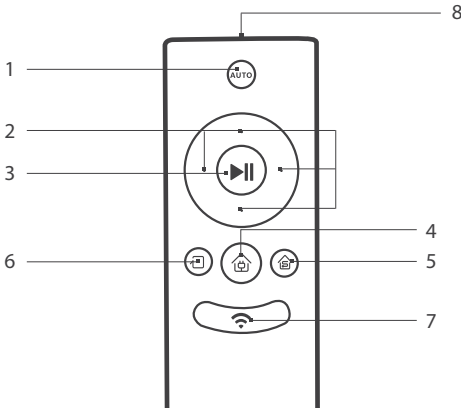

1. AUTO Mode Button
2. Direction Control Buttons
3. START/PAUSE Button
4. Return to Charger Mode Button
5. Single Room Mode Button
6. Edge Cleaning Mode Button
7. Network Setup Button
8. Infrared Emitter

Dust Bin

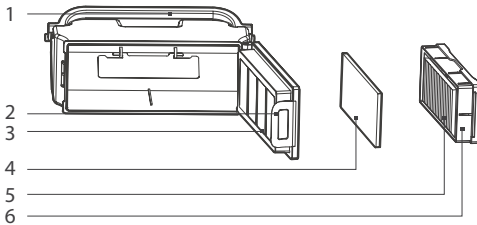

1. Dust Bin Handle
2. Dust Bin Lock
3. Filter Net
4. Sponge Filter
5. High Efficiency Filter
6. Dust Bin Cover

Advanced Wet/Dry Reservoir

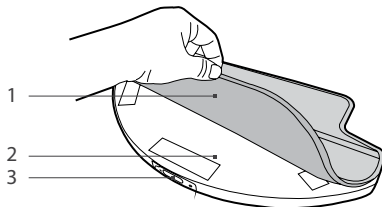

1. Advanced Wet/Dry Cleaning Cloth
2. Advanced Wet/Dry Reservoir
3. Water Inlet

3. Operating and Programming

3.1 Notes Before Cleaning

Before operating DEEBOT, take a few moments to survey the area to be cleaned and remove any obstacles.

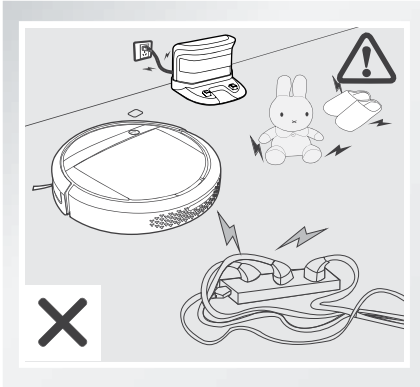

Remove power cords and small objects from the floor that could entangle the product.

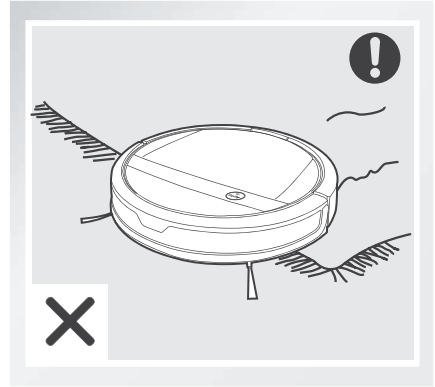

The product is not suitable for use on long-pile carpet. Before using the product near an area rug or on a short-pile area rug with tasseled edges, please fold area rug edges under themselves.

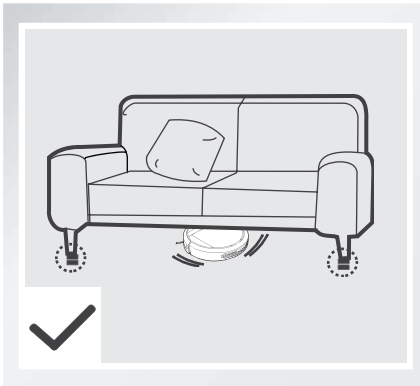

Please be aware that the robot needs at least an 8 cm (3.15") clearance to clean under furniture without complications.

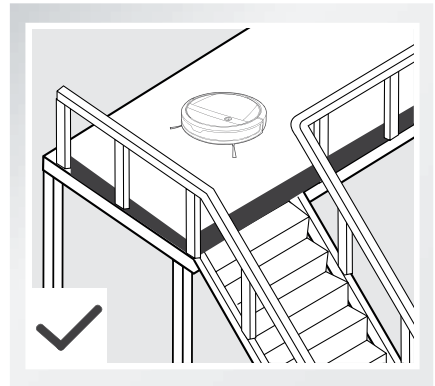

If there is a step or stairs in the cleaning area, please operate DEEBOT to ensure its Anti-Drop Sensors can detect the drop off. It may be necessary to place a physical barrier at the edge of the drop off to keep the unit from falling over the edge.

3. Operating and Programming

When DEEBOT is cleaning using Programmed Cleaning Pattern, please do not stand in narrow spaces, such as hallways, or DEEBOT may fail to identify the area to be cleaned.

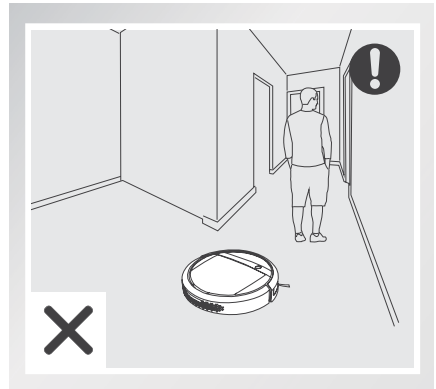

3.2 Quick Start

- * Remove the Bumper Rail protection sponge on the DEEBOT before the first use.

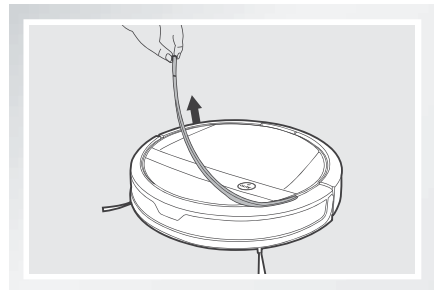

1 Charging Dock Placement

- Place the Charging Dock on a level floor surface against the wall with the base perpendicular to the ground. Keep the immediate area 1.5m (5') in front of the charger and 0.5m (1.6') on both sides of the charger clear of objects and reflective object surfaces.
- Plug the Charging Dock in.

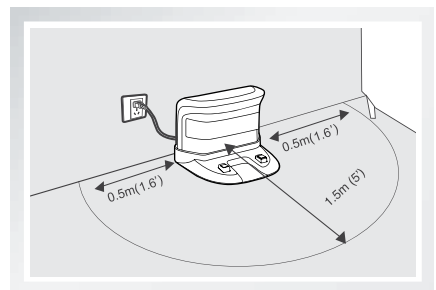

3. Operating and Programming

2 Install Side Brushes

- Attach Side Brushes to the bottom of DEEBOT by pressing a brush into each slot with the matching color until it clicks.

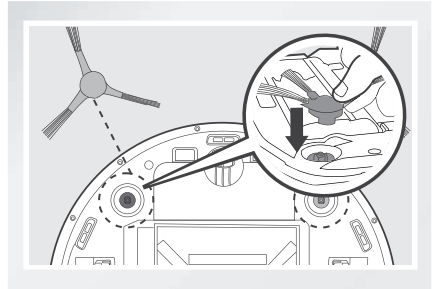

3 Power ON

- Turn the robot's Bottom Power Switch to the ON position. "I"=power ON; "O"=power OFF. Press and hold AUTO Mode Button on the robot. DEEBOT is powered ON when the AUTO Mode Button glows a continuous BLUE.

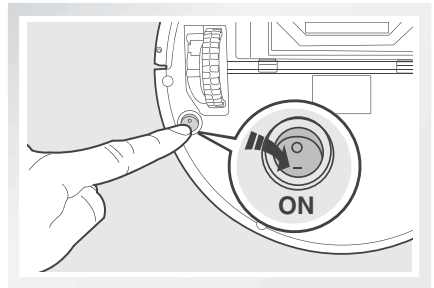

* When DEEBOT is not cleaning, it is suggested to keep it powered ON and charging instead of powered OFF.

4 Charge DEEBOT

- Place DEEBOT on the Charging Dock making sure the Charging Contacts on DEEBOT and the Charging Dock Pins make a connection.
- Charge DEEBOT for at least 4 hours before the first use.

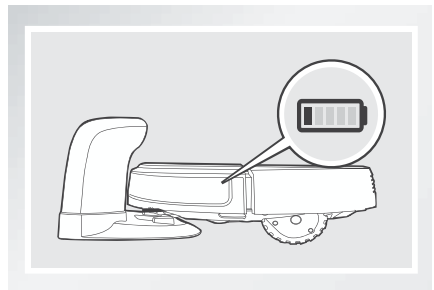

* Make sure to turn the robot's Bottom Power Switch to the ON position before charging. ("I"=power ON; "O"=power OFF. The robot's default setting is "O".) DEEBOT is powered ON when the AUTO Mode Button glows a continuous BLUE.

* AUTO Mode Button blinks when DEEBOT is charging. AUTO Mode Button stops glowing when DEEBOT is fully charged.

* Remove the Water Reservoir before charging DEEBOT.

3. Operating and Programming

5 Start

- Press the AUTO Mode Button on DEEBOT or on the Remote Control. DEEBOT starts to work immediately in AUTO Cleaning Mode using the default Random Cleaning Pattern.

* To choose another Cleaning Mode or Cleaning Pattern, please refer to section 3.3 Cleaning Pattern and Cleaning Mode Selection for details.

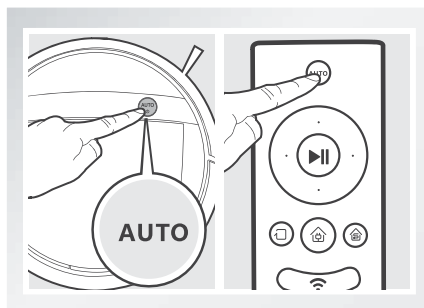

6 Pause

- Pause DEEBOT by pressing the AUTO Mode Button on DEEBOT or the START/PAUSE Button on the Remote Control.

* Press AUTO Mode Button on DEEBOT or the START/PAUSE Button on the Remote Control to restart.

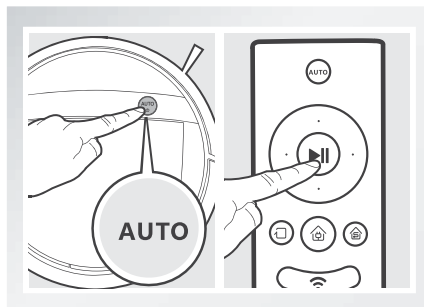

* DEEBOT can be directed to move forward, backward, left and right using the Direction Control Buttons on the Remote Control when it is Paused. DEEBOT cleans when it is directed to move forward using the Remote Control.

* The AUTO Mode Button on the robot's Control Panel stops glowing after the robot is paused for more than 5 minutes. Press AUTO Mode Button on the robot to wake up the robot, or press any button on the Remote Control to start the robot immediately.

7 Power OFF

- Pause DEEBOT. Move the Bottom Power Switch to the OFF position.

* When DEEBOT is not cleaning, it is suggested to keep it powered ON and charging.

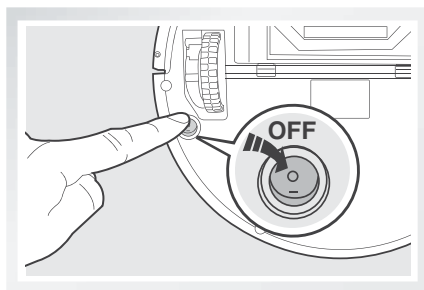

3. Operating and Programming

3.3 Cleaning Pattern and Cleaning Mode Selection

DEEBOT has 2 Cleaning Patterns and several Cleaning Modes to choose from to effectively clean different floors. Cleaning Patterns and Cleaning Modes are selected using the Remote Control or the ECOVACS App. For more information on the ECOVACS App, see the separate ECOVACS App leaflet.

Set Cleaning Pattern

Set the cleaning pattern based on floor type.

Random Cleaning Pattern (default pattern)

Random Cleaning Pattern is the robot's default pattern and should be set when cleaning carpet. In Random Pattern, DEEBOT cleans in a straight line and changes directions when it meets an obstacle.

Programmed Cleaning Pattern

Programmed Cleaning Pattern should be set when cleaning bare floors. In Programmed Cleaning Pattern the robot plans the most efficient route, cleans in a back and forth straight-line pattern, returns to clean missed spots, then cleans room edges before completing the cleaning cycle.

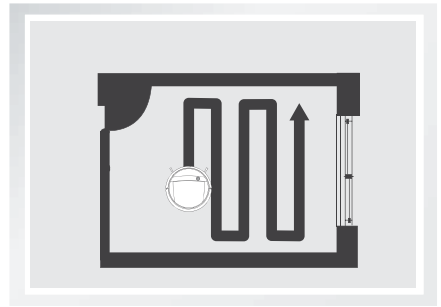
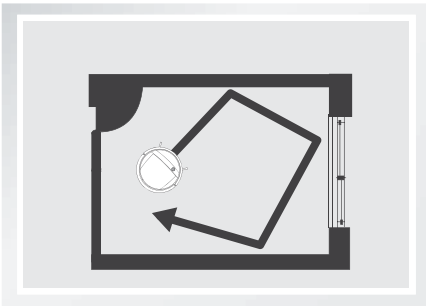

When Programmed Cleaning Pattern is Set:

- * DEEBOT automatically conducts route planning when cleaning. If the robot is paused, moved manually or directed by the Remote Control during cleaning, DEEBOT will reconfigure the route and restart. Therefore, avoid using the Remote Control or moving DEEBOT manually when it is cleaning to ensure efficiency.
- * DEEBOT may pause temporarily to recalculate its cleaning path. This is normal. Please be patient, the frequency and duration of the pause is determined by room complexity.
- * If the cleaning environment contains both bare floors and carpet, barriers (for example a closed door) should be set between different floor types and cleaning patterns should be set accordingly. If both floor types are to be cleaned in one cleaning cycle, Random Cleaning Pattern should be set.

3. Operating and Programming

Press and hold the AUTO Mode Button on the Remote Control for 3 seconds. Programmed Cleaning Pattern is set when DEEBOT emits two beeps. To switch back to Random Cleaning Pattern, press and hold the AUTO Mode Button on the Remote Control for 3 seconds. Random Cleaning Pattern is set when DEEBOT emits one beep.

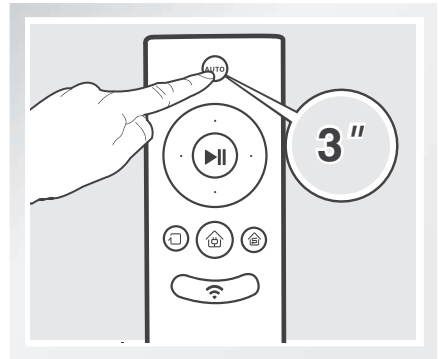

Cleaning Patterns can also be set using the ECOVACS App.

DEEBOT uses the set Cleaning Pattern when cleaning in AUTO Cleaning Mode and Single Room Cleaning Mode.

Select Cleaning Mode

1 AUTO Cleaning Mode

This is the most commonly used mode and is good for every day cleaning.

To start AUTO Cleaning Mode, press the AUTO Mode Button on the robot, on the Remote Control, or  on the App main screen.

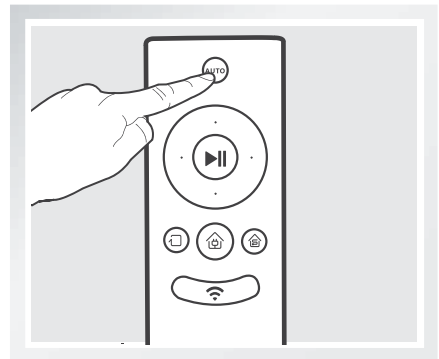

* AUTO Cleaning Mode cleans using the Cleaning Pattern set in the previous step. Random Cleaning Pattern is best for carpet. Programmed Cleaning Pattern is best for bare floors.

* When the cleaning cycle is complete, DEEBOT returns to the Charging Dock.

3. Operating and Programming

2 Single Room Mode

This mode is used when DEEBOT only needs to clean a single room with a maximum size of 30 m² (323 sq ft). To start Single Room Cleaning Mode, press the Single Mode Button on the Remote Control or  on the App main screen.

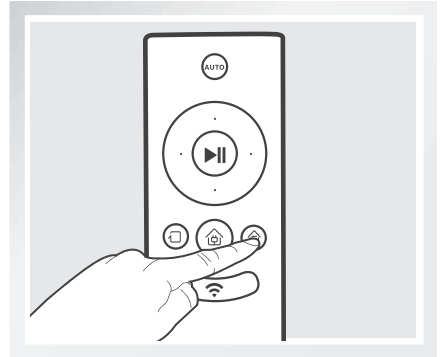

- * Single Room Cleaning Mode cleans using the set Cleaning Pattern. Random Cleaning Pattern is best for carpet. Programmed Cleaning Pattern is best for bare floors.
- * The room must be contained for Single Room Mode to function properly. Close doors to the room entrance and exit to contain the room.

3 Spot Cleaning Mode (2-5 minutes)

This mode is applicable for a small area of highly concentrated dirt or dust. To start Spot Cleaning Mode, press  on the App main screen. In Spot Cleaning Mode, DEEBOT focuses on a specific area to clean. DEEBOT cleans the area in a spiral pattern and returns to its starting point when it completes cleaning.

- * Spot Cleaning Mode can only be started using the App.

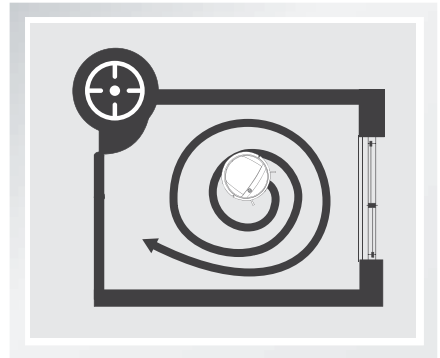



3. Operating and Programming

4 Edge Cleaning Mode

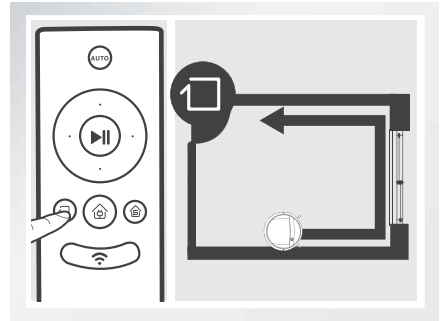
This mode is good for cleaning the edges and corners of a room. To start Edge Cleaning Mode, press the Edge Cleaning Mode Button on the Remote control or  on the App main screen. In Edge Cleaning Mode, DEEBOT cleans along a border (e.g. wall), and returns to the Charging Dock when it completes cleaning.



* Use the App to increase the suction power of any Cleaning Mode already in process. Press  in the App for MAX suction power. Press  to switch back to standard suction power.

5 Return to Charger Mode

When battery power gets low, DEEBOT automatically switches to Return to Charger Mode and returns to the Charging Dock to recharge itself.

* DEEBOT can also be sent back to the Charging Dock at any time by pressing the Return to Charger Button on the Remote Control or  on the App main screen.

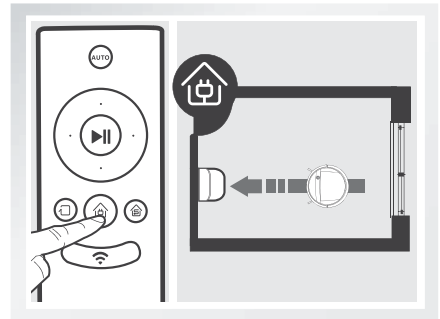

3. Operating and Programming

3.4 Programming the Robot

DEEBOT has an Intelligent Scheduling and a Time Scheduling function to schedule cleaning times. DEEBOT can be programmed to automatically clean once per day at the same time with Intelligent Scheduling using the robot's Control Panel. DEEBOT can also be programmed weekly to clean up to two times per day at specific times with Time Scheduling using the App.

* All scheduled cleanings are performed in AUTO Cleaning Mode using the Random Cleaning Pattern.

Intelligent Scheduling

1 Set Intelligent Scheduling

DEEBOT can be scheduled to clean once per day at the same time, even if nobody is at home.

Press the Auto Mode Button on the robot twice to set the current time as the scheduled cleaning time. Intelligent Scheduling is set successfully when the robot beeps twice. DEEBOT automatically cleans at the scheduled cleaning time every day.

For example: Set Intelligent Scheduling successfully at 9:00am, and DEEBOT automatically cleans at 9:00am every day.

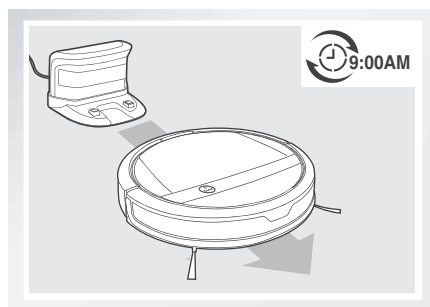
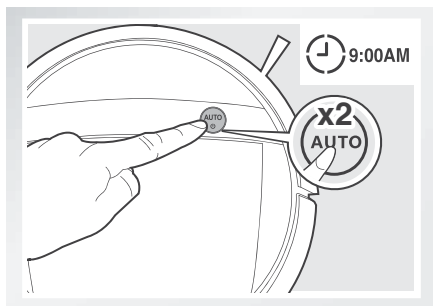

2 Cancel Intelligent Scheduling

Press the Auto Mode Button on the robot twice. Intelligent Scheduling is cancelled when the robot beeps three times.

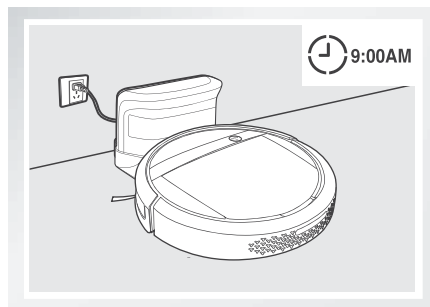
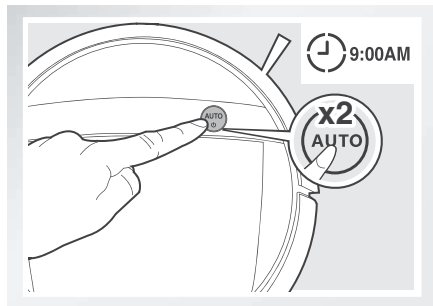

* To automatically clean at another time, first cancel the current Intelligent Scheduling, then set Intelligent Scheduling again at the desired time.

* If DEEBOT is powered OFF, Intelligent Scheduling is cancelled.

3. Operating and Programming

Time Scheduling

Set Time Scheduling

DEEBOT can be programmed weekly to clean multiple times per day at specific times using the ECOVACS App.

Open the ECOVACS App. Press "... " in top right corner on the App's main screen. Set new scheduled cleanings and cancel existing scheduled cleanings in "Time Scheduling."

* Please allow at least 7 hours between scheduled cleaning times.

3.5 Choosing a Suction Option

The robot has 2 interchangeable suction options for your convenience.

Main Brush Option: The best choice for deep cleaning with a combination of the Main Brush and strong suction. The Main Brush Option comes pre-installed in DEEBOT.

Direct Suction Option: The best choice for daily cleaning with the Main Brush removed for direct suction. This Suction Option is specifically designed to pick up hair without tangling.

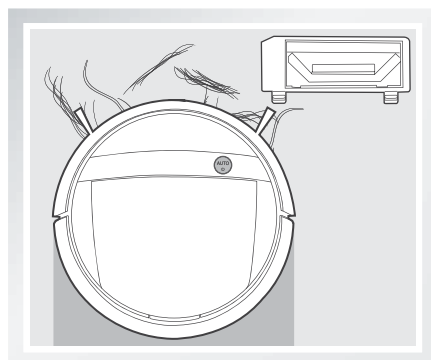
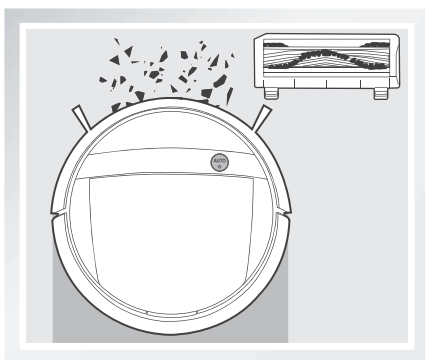

Install the Direct Suction Option

Turn the robot over. Push both buttons on the Main Brush Option and remove the Main Brush Cover. Remove the Main Brush.

Line up the Direct Suction Option tabs with the slots on the bottom of the robot. Press until the component clicks into place.

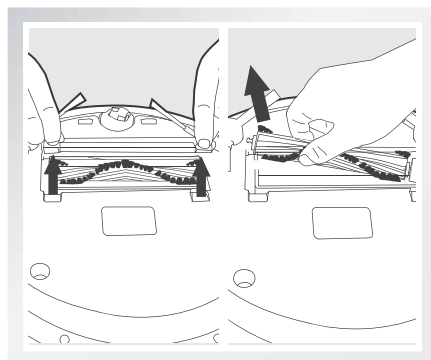

3. Operating and Programming

Install the Main Brush Option

Turn the robot over. Push both buttons on the Direct Suction Option and remove Direct Suction Option.

Insert the Main Brush into the bottom of the robot.

Line up the Main Brush Cover tabs with the slots on the bottom of the robot. Press until the component clicks into place.

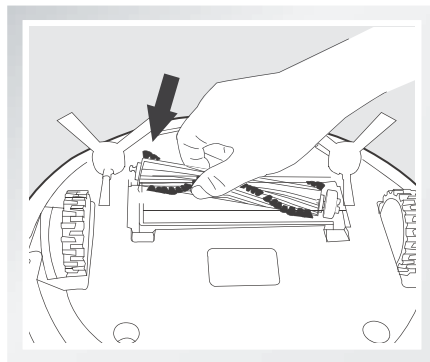

3.6 Optional Advanced Wet/Dry Mopping System

DEEBOT has an optional Advanced Wet/Dry Mopping System using a Advanced Wet/Dry Cleaning Cloth attached to a proprietary Advanced Wet/Dry Reservoir. The washable/reusable Cleaning Cloth automatically damp mops and then dries the floor to a spotless clean.

- * Do not use the mopping system on carpet.
- * When using the mopping system, fold area rug edges under themselves so DEEBOT will avoid the rug.
- * When using the mopping system, do not stop the robot and allow it to stand still. This prevents the Cleaning Cloth from leaving water on the floor.
- * Remove the Advanced Wet/Dry Reservoir before charging DEEBOT.

1 Attach Advanced Wet/Dry Cleaning Cloth to the Reservoir

- Attach the Advanced Wet/Dry Cleaning Cloth to the Advanced Wet/Dry Reservoir. Ensure that the blue and white side of the Cleaning Cloth faces out.

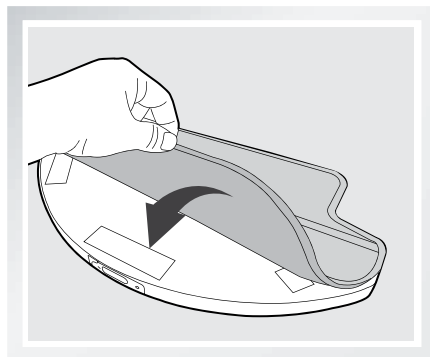

3. Operating and Programming

2 Add Water to the Advanced Wet/Dry Reservoir

* Before adding water to the Advanced Wet/Dry Reservoir remove the Advanced Wet/Dry Reservoir from the bottom of the robot.

Fill the provided Measuring Cup with water. Open the Water Inlet lid on the Advanced Wet/Dry Reservoir and slowly pour water from the Measuring Cup into the Reservoir. Close the Water Inlet lid.

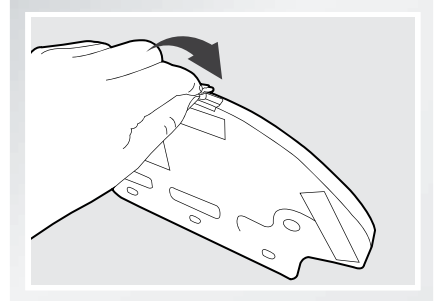
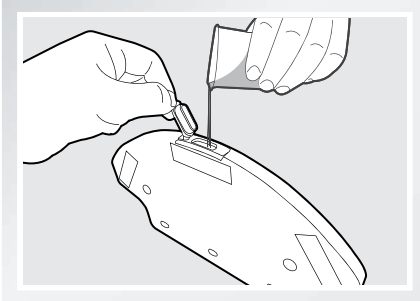

Attach the Advanced Wet/Dry Reservoir to the bottom of the robot. Insert the tabs on the Advanced Wet/Dry Reservoir into the Advanced Wet/Dry Reservoir Slots on the bottom of the robot until you hear a click.

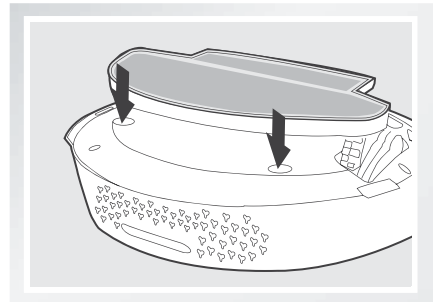

3. Operating and Programming

3 Start

- Select the desired Cleaning Mode. DEEBOT sweeps, lifts, vacuums, mops and dries in the selected mode.

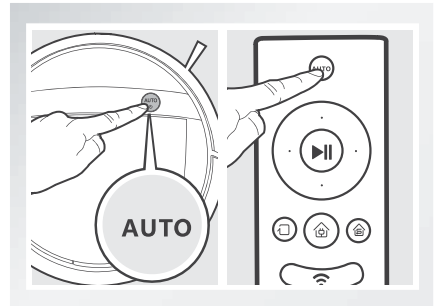

- * It is suggested to select Single Room Mode when using the optional Advanced Wet/Dry Mopping System for maximum efficiency.
- * To mop another room, move DEEBOT to the room to be cleaned, refill the Water Reservoir/ change the Cleaning Cloth as needed and restart.
- * If DEEBOT is Paused during mopping to refill the Water Reservoir or change the Cleaning Cloth, DEEBOT will reconfigure its cleaning route, and restart the cleaning cycle.

4 Remove

- After DEEBOT finishes mopping, remove the Advanced Wet/Dry Reservoir from DEEBOT, empty any remaining water from the Reservoir, and remove the Advanced Wet/Dry Cleaning Cloth.

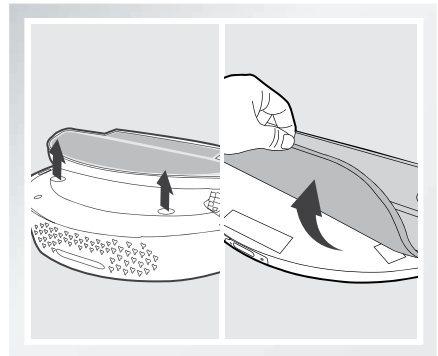

3. Operating and Programming

3.7 Alarm Indicator and Sounds

If DEEBOT detects a problem and needs your assistance, it emits alarm beeps and the AUTO Mode Button flashes RED.

Alarm Sound	Problems	Solution
One Beep	Driving Wheel Malfunction	Check Driving Wheels for tangled hair or debris and clean as described in section 4 Maintenance.
Three Beeps	Driving Wheel Malfunction	Turn over the robot. Press Driving Wheels to check for a clicking sound. If they do not click, please contact Customer Service.
	DEEBOT gets into trouble while working and stops	Manually remove the obstacles and restart DEEBOT.
Four Beeps	Dust Bin Malfunction	Remove the Dust Bin and re-install it properly. If the robot still emits the alarm, please contact Customer Service.
Five Beeps	Low Battery	Manually place the robot on the Charging Dock to charge.
Six Beeps	Side Brush Malfunction	Check Side Brushes for tangled hair or debris and clean as described in section 4 Maintenance.
Seven Beeps	Anti-Drop Sensor Malfunction	Check Anti-Drop Sensors for dust and clean as described in section 4 Maintenance.

4. Maintenance

Before performing cleaning and maintenance, power OFF DEEBOT and unplug the Charging Dock.

4.1 Dust Bin and Filters

Cleaning the Dust Bin and Filters

Open the robot's Top Cover and remove the Dust Bin. Open the Dust Bin Lock and empty the Dust Bin.

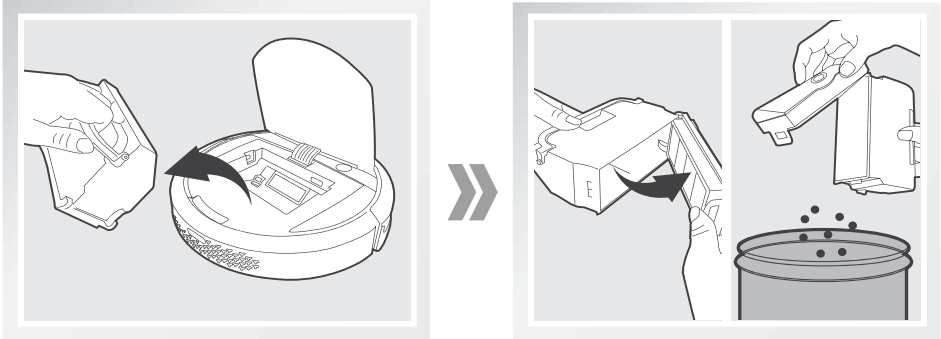

Remove the filters. Pat the High Efficiency Filter clean. Do not rinse the High Efficiency Filter under water.

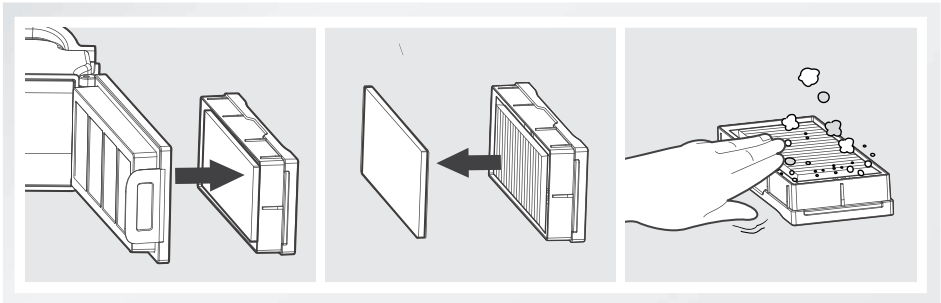

Rinse the Sponge Filter, Dust Bin and Filter Net under running water.

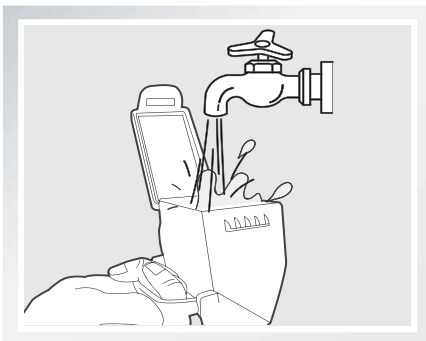

Dry the Dust Bin and filters completely before reinstalling.

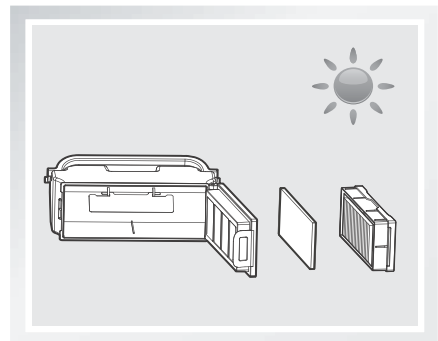

4. Maintenance

4.2 Advanced Wet/Dry Cleaning Cloth an Advanced Wet/Dry Reservoir

Cleaning the Advanced Wet/Dry Cleaning Cloth

If the mopping system was used, remove the Advanced Wet/Dry Reservoir from the bottom of DEEBOT and remove the Advanced Wet/Dry Cleaning Cloth.

Empty any remaining water from the Reservoir.

Wash the Cleaning Cloth by hand, and lay flat to dry.

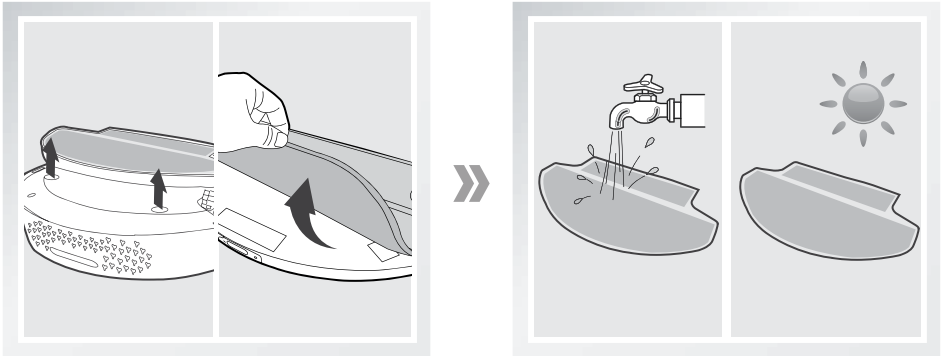

Cleaning the Advanced Wet/Dry Reservoir

If the mopping system was used, remove the Advanced Wet/Dry Reservoir from the bottom of DEEBOT.

Empty any remaining water from the Reservoir, and set out to dry.

Wipe the outside of the Advanced Wet/Dry Reservoir with a dry cloth.

If the Advanced Wet/Dry Reservoir does not run out of water after DEEBOT cleans for 60 minutes, the water outlets on the Reservoir are clogged. Clean the Reservoir with the provided ECOVACS Reservoir Cleaning Solution according to the instructions on the bottle of the solution.

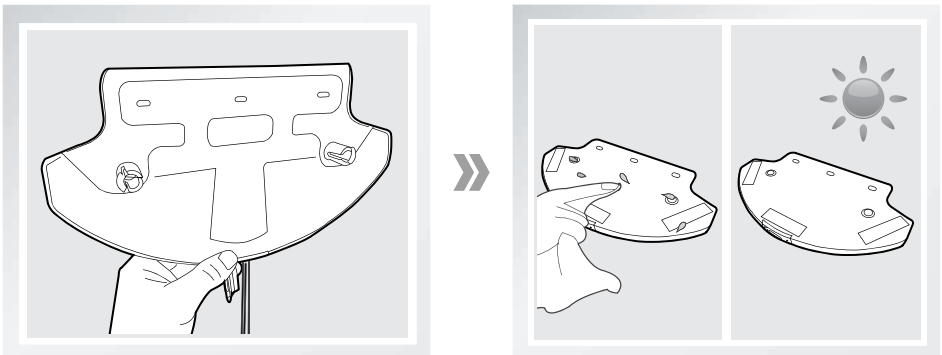

4. Maintenance

4.3 Main Brush, Direct Suction Option and Side Brushes

* A Multi-Function Cleaning Tool is provided for easy maintenance. Handle with care, this cleaning tool has sharp edges.

Cleaning the Main Brush

Turn the robot over. Push both buttons on the Main Brush Option and remove the Main Brush cover. Remove the Main Brush. Use the Multi-Function Cleaning Tool to cut off and remove any hair tangled around the Main Brush.

Clean any tangled hair or debris from both ends of the Main Brush and inside the plastic caps.

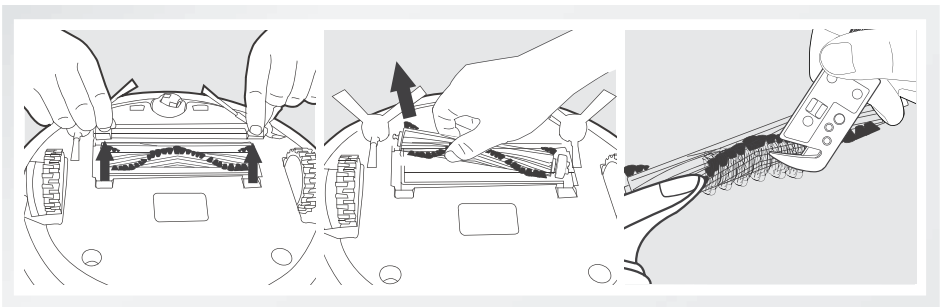

Cleaning the Direct Suction Option

Wipe the Direct Suction Option clean with a dry cloth.

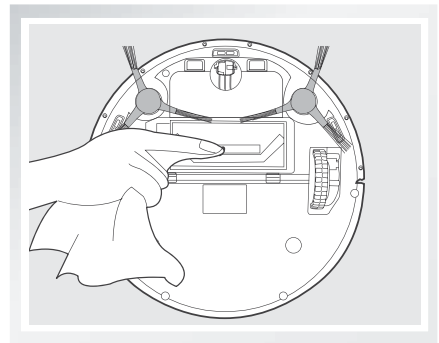

Cleaning the Side Brushes

Remove any hair or debris tangled around the Side Brushes with the provided Multi-Function Cleaning Tool. Remove the Side Brushes and wipe the Side Brushes and their slots with a clean cloth.

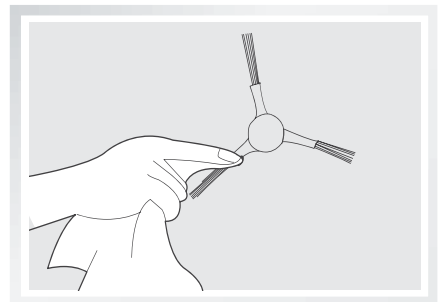

4. Maintenance

4.4 Other Components

Use the Multi-Function Cleaning Tool to cut off and remove any hair tangled around the Universal Wheel.

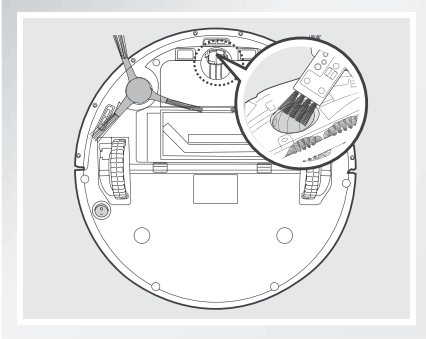

Wipe the Anti-Drop Sensors with the brush or felt side of the Multi-Function Cleaning Tool to maintain their effectiveness.

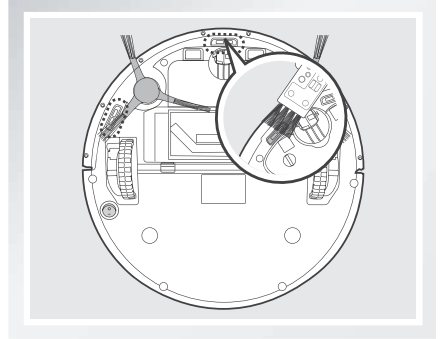

Wipe the robot's Charging Contacts and Charging Docks Pins with the brush of the Multi-Function Cleaning Tool or with a dry cloth to maintain their effectiveness.

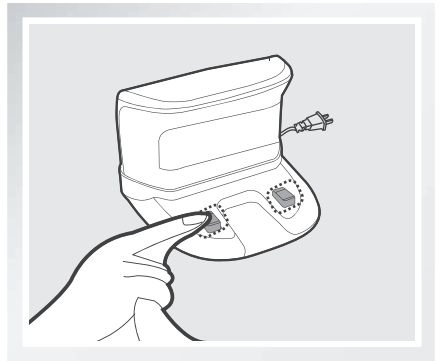
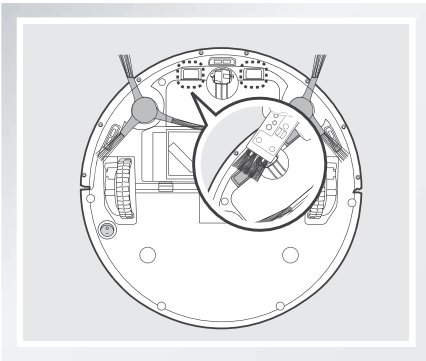

5. Troubleshooting

Please use this chart to troubleshoot common problems using DEEBOT.

No.	Malfunction	Possible Causes	Solutions
1	DEEBOT will not charge.	DEEBOT is not powered ON.	Move the robot's Bottom Power Switch to the ON position.
		DEEBOT has not made a connection with the Charging Dock.	Be sure that the robot's Charging Contacts have made a connection with the Charging Dock Pins. You may move the robot manually to make the connection if necessary.
		The Charging Dock is unplugged while DEEBOT is powered ON, which causes battery consumption.	Plug in the Charging Dock and ensure DEEBOT is powered ON. Keep DEEBOT on the Charging Dock to make sure it has full battery to work at any time.
		The battery is completely discharged.	Re-activate the battery.
2	DEEBOT will not return to the Charging Dock.	The Charging Dock is placed incorrectly.	Please refer to section 3.2 Quick Start for details on proper Charging Dock placement.
3	DEEBOT gets into trouble while working and stops.	DEEBOT is tangled with something on the floor (electrical cords, drooping curtains, area rug fringe etc.).	DEEBOT will try various ways to get itself out of trouble. If it is unsuccessful, manually remove the obstacles and restart.
		The Side Brushes are tangled with hair or debris, and low rotation speed causes DEEBOT to Pause and triggers an alarm.	Check Side Brushes for tangled hair or debris, clean as described in section 4 Maintenance and restart. If the Side Brushes still rotate slowly, please contact Customer Service.
		The Main Brush is stuck, and low rotation speed causes DEEBOT to Pause and triggers an alarm.	Remove the Main Brush Cover and remove the Main Brush. Clean any tangled hair or debris on the Main Brush as described in section 4 Maintenance and restart. If DEEBOT does not function normally, replace the Main Brush.

5. Troubleshooting

No.	Malfunction	Possible Causes	Solutions
4	DEEBOT returns to the Charging Dock before it finishes cleaning.	When battery power gets low, DEEBOT automatically switches to Return to Charger Mode and returns to the Charging Dock to recharge itself.	This is normal. No solution necessary.
		Working time varies according to floor surface, room complexity and the selected Cleaning Mode.	This is normal. No solution necessary.
5	DEEBOT will not clean automatically at scheduled time.	Intelligent Scheduling/ Time Scheduling function is cancelled.	Set Intelligent Scheduling or Time Scheduling. Please refer to section 3.4 Programming the Robot for details.
		DEEBOT is powered OFF.	Power ON DEEBOT.
		The robot's battery is low.	Keep DEEBOT powered ON and on the Charging Dock to make sure it has full battery to work at any time.
		The robot's components are blocked and/or its components are tangled with debris.	Turn the robot's power OFF, clean the Dust Bin and invert the robot. Clean the robot's Main Brush, Side Brushes and other components as described in section 4 Maintenance.
6	DEEBOT misses the spots to be cleaned.	Items on the floor in the cleaning area need to be put away.	Please refer to section 3.1 Notes Before Cleaning for details.
		Cleaning frequency is too low.	Daily cleaning is suggested to obtain best results.

5. Troubleshooting

No.	Malfunction	Possible Causes	Solutions
7	Remote Control failure (Effective control range of the Remote Control is 5m (16')).	The battery in the Remote Control need to be replaced.	Replace with a new battery making sure it is installed correctly.
		DEEBOT is powered OFF or the robot's battery is low.	Make sure DEEBOT is powered ON and fully charged.
		The infrared signal cannot be transmitted because the Infrared Emitter on Remote Control or the Infrared Receiver on DEEBOT is dirty.	Use clean dry cloth or the brush side of the provided Multi-Function Cleaning Tool to wipe the Infrared Emitter on Remote Control and the Infrared Receiver on DEEBOT.
		There is other equipment interfering with the infrared signal to DEEBOT.	Avoid using the Remote Control near other equipment using infrared signals.



Designed and Manufactured by/Conception et fabrication par/
Diseñado y fabricado por

ECOVACS ROBOTICS, Co., Ltd.

MADE IN CHINA/FAIT EN CHINE/HECHO EN CHINA

Distributed by/Distribué par/Distribuido por

ECOVACS ROBOTICS, Inc.

Canton, OH, USA/Canton, OH, É.-U./Canton, OH, EE. UU.

DM88-AM01-IM2016R01