

luxier®

Escutcheon Deck Plate

Model Number:

DKPL-6

DKPL-7

DKPL-10

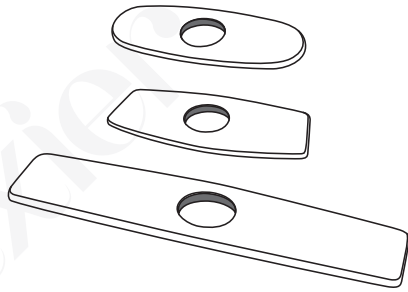

Installation

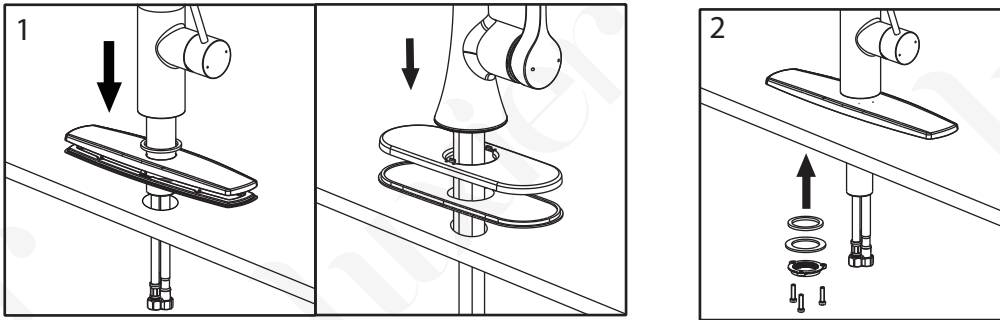

Kitchen Sink / Bathroom Sink

1. Place the deck plate onto the mounting surface. Align the plate and make sure the unused holes are covered completely. (NOTE: make sure the supporting rubber spacer is seated properly under the deck plate.)
2. Place the faucet on the deck plate through the opening. Carefully secure the faucet and the deck plate with the supplied mounting hardware from the faucet manufacturer. Do not overtighten as it will damage both the faucet and the deck plate.

Maintenance Guide

Please follow the cleaning material manufacturer's instructions. Damage caused by improper treatment will not be covered by product warranty. In addition, pay attention to the following points:

- Regular cleaning can prevent mineral build up on faucet spout.
- Carefully read the cleaner product label to ensure the cleaner is safe for use on the material.
- Test the cleaner on a small area before using on the entire surface.
- Use a mild detergent such as liquid dishwashing soap and warm water for cleaning.
- Do not use abrasive / harsh chemical when cleaning the fixture as they will damage and dull the finish.
- When using spray cleaners, spray first onto a soft cloth or sponge. Never spray directly onto the faucet as droplets can enter openings and gaps and cause damage.
- After cleaning, rinse thoroughly with clean water to remove any cleaner residue.

Thank you for purchasing Luxier products. Please read the information below and keep this installation guide for future reference. If you require assistance, please contact our customer service department at 1-877-711-8828, Monday - Friday 9AM - 5PM Pacific Time or by email at support@luxierusa.com.

Limited Lifetime Warranty (For USA Only)

The manufacturer warrants this product to be leak and drip free during daily normal household use for as long as it is owned by the original purchaser of this product. Please keep a copy of the original invoice as proof of purchase.

Should a malfunction occur within the warranty period, Luxier USA will, as its option, (1) repair or replace the defective part(s) or product at no charge; (2) issue a refund of the purchase price paid for the product (Valid within 30 days from the date of purchase); or (3) issue a credit to be applied against the purchase of a new Luxier product. Shipping/delivery charges may apply and are in Luxier USA's sole discretion.

This limited warranty shall not apply to goods which have been subject to accident, negligence, improper installation, product abuse, product misuse, or use of cleaners containing abrasives, alcohol or other organic solvents, whether performed by a contractor, service company, or yourself, are excluded from this warranty.

Our responsibility under this warranty is limited to only to replacement parts and no other costs. Luxier USA will not be responsible for labor charges and/or damage incurred by installation, repair or replacement, nor for any indirect incidental or consequential damages, losses, injury or costs of any nature relating to this faucet. Except as provided by law, this warranty is in lieu of and excludes all other warranties, conditions, and guarantees, whether expressed or implied, statutory or otherwise, including without restriction those merchantability of fitness for use.

This limited warranty is non-transferable. This limited warranty only applies to products purchased and installed in the United States. This limited warranty covers the original consumer purchase only and does not include business, commercial or industrial use of this product. To obtain service under the Limited Warranty, please contact Luxier USA at support@luxierusa.com. The Luxier USA Customer Care Department will determine whether to repair or replace your product, issue a refund, or issue a credit.