

USE AND CARE GUIDE

LED MINI PENDANT

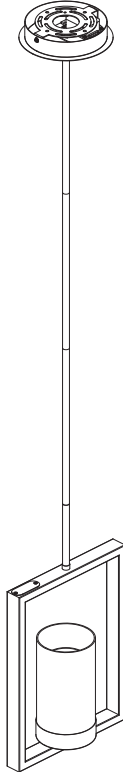

Questions, problems, missing parts? Before returning to the store,
call Home Decorators Collection Customer Service
8 a.m. - 7 p.m., EST, Monday – Friday, 9 a.m. - 6 p.m., EST, Saturday

1-800-986-3460

WWW.HOMEDEPOT.COM/HOMEDECORATORS

THANK YOU

We appreciate the trust and confidence you have placed in Home Decorators Collection through the purchase of this LED Mini Pendant. We strive to continually create quality products designed to enhance your home. Visit us online to see our full line of products available for your home improvement needs. Thank you for choosing Home Decorators Collection!

Table of Contents

Table of Contents.....	2	Hardware Included.....	3
Safety Information.....	2	Package Contents.....	4
Warranty.....	2	Installation.....	5
Pre-Installation.....	3	FCC Statement.....	7
Planning Installation	3	Care & Cleaning.....	7
Tools Required.....	3	Troubleshooting.....	7

Safety Information

- Read all instructions before assembling and installing.
- Consult a qualified electrician for installation of this fixture.
- If you have any non-electrical questions about this fixture, please contact our Customer Service Team at 1-800-986-3460 or visit www.homedepot.com/homedecorators.
- Please reference your SKU 1003 547 754 or (UPC 773546287609).
- Keep your receipt and these instructions for proof of purchase.



CAUTION: Before starting installation of this fixture or removal of a previous fixture, disconnect the power by turning off the circuit breaker or by removing the fuse at the fuse box.



IMPORTANT: Do not install this lighting system in damp or wet locations.



IMPORTANT: Inspect the wire insulation for any cuts, abrasions, or exposed copper that have occurred during shipping. If there is a defect in the wire, do not continue the assembly process. Please call our Customer Service Team at 1-855-HD-HAMPTON.

Warranty

LIMITED WARRANTY

WHAT IS COVERED

The manufacturer warrants this lighting fixture to be free from defects in materials and workmanship for a period of three (3) years from date of purchase. This warranty applies only to the original consumer purchaser and only to products used in normal use and service. If this product is found to be defective, the manufacturer's only obligation, and your exclusive remedy, is the repair or replacement of the product at the manufacturer's discretion, provided that the product has not been damaged through misuse, abuse, accident, modification, alteration, neglect, or mishandling.

WHAT IS NOT COVERED

This warranty shall not apply to any product that is found to have been improperly installed, set-up, or used in any way not in accordance with the instructions supplied with the product. This warranty shall not apply to a failure of the product as a result of an accident, misuse, abuse, negligence, alteration, faulty installation, or any other failure not relating to faulty material or workmanship. This warranty shall not apply to the finish on any portion of the product, such as surface and/or weathering, as this is considered normal wear and tear. The manufacturer does not warrant and specially disclaims any warranty, whether express or implied, of fitness for a particular purpose, other than the warranty contained herein. The manufacturer specifically disclaims any liability and shall not be liable for any consequential or incidental loss or damage, including but not limited to any labor/expense costs involved in the replacement or repair of said product.

Contact Customer Care at 1-800-986-3460 or visit www.homedepot.com/homedecorators.

Pre-Installation

PLANNING INSTALLATION

Read all instructions before assembly and installation. To avoid damaging this product, assemble it on a soft, non-abrasive surface, such as carpet or cardboard. Inspect each part for defects that may have occurred during shipping. Keep your receipt and these instructions for proof of purchase.

TOOLS REQUIRED



Safety goggles

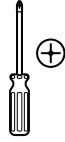

Phillips screwdriver



Flathead screwdriver

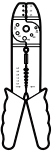

Wire strippers



Wire cutters



Ladder

HARDWARE INCLUDED



NOTE: Hardware not shown to actual size.

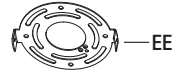

Part	Description	Quantity
AA	Wire nut	5
BB	Outlet box screw	2
CC	Ground screw	1
DD	Mounting screw	2
EE	Universal crossbar	1

Pre-Installation (continued)

PACKAGE CONTENTS

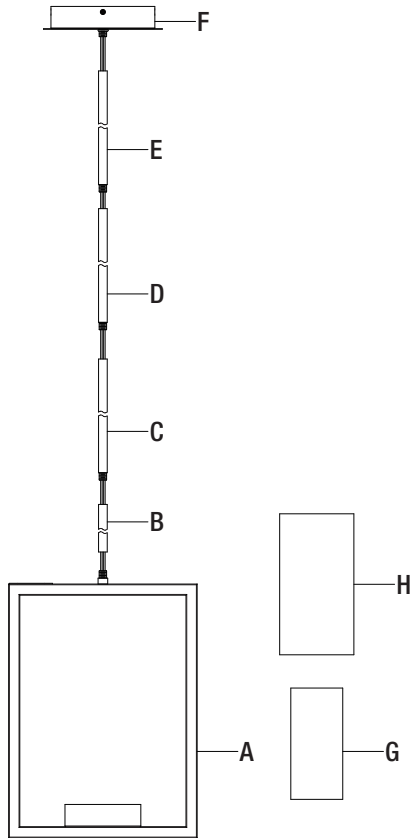

Part	Description	Quantity
A	Fixture body	1
B	Center rod B	1
C	Center rod C	1
D	Center rod D	1
E	Center rod E	1
F	Canopy	1
G	Small glass	1
H	Large glass	1

Installation

1 Installing the center rods

WARNING: Turn off power at the main fuse box.

- Carefully unpack the fixture. Lay out all the parts on a clean surface.
- Unfold the fixture arms, as shown below.
- Unravel the supply power and ground wires and pass them through the center hole of the rod (B), (C), (D), (E), and canopy (F).
- Install center rods (B), (C), (D), (E), and the canopy (F) by twisting each piece clockwise as the figure shows.

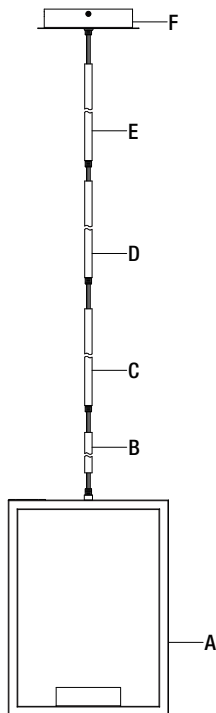

2 Making the electrical connections

NOTE: Always use the wire nuts (AA) to connect wires and push all excess wires and connections back into the canopy (F).

- Connect the red wire of the driver to the red wire of the fixture and connect the blue wire of the driver to the blue wire of the fixture.

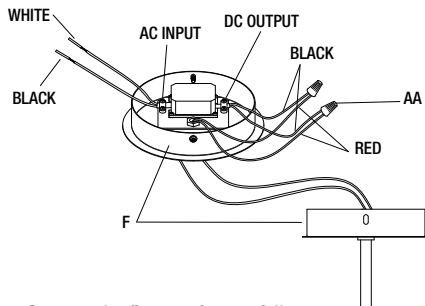

- Connect the fixture wires as follows.

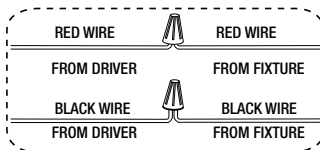

3 Installing the universal crossbar

WARNING: Turn off power at the main fuse box.

- Secure the universal crossbar (EE) to the junction box (not included) with the two outlet box screws (BB).

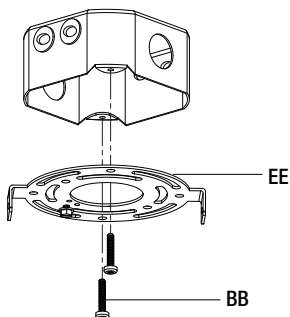

Installation (continued)

4 Making the electrical connections



NOTE: Always use the wire nuts (AA) to connect wires and push all excess wires and connections back into the junction box (not included).

- Connect the ground wire from the branch circuit to the ground screw (CC) on the universal crossbar (EE).

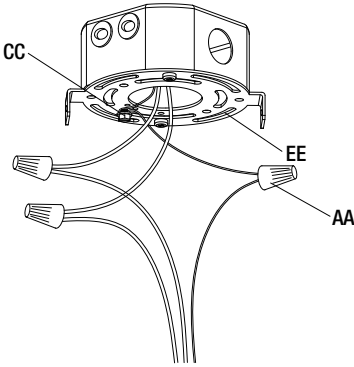

- Connect the fixture wires as follows.

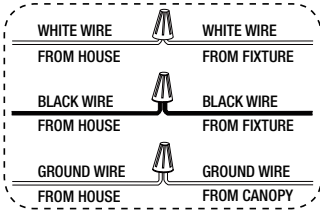

5 Installing the canopy

- Install the canopy (F) in the universal crossbar (EE) with mounting screws (DD).

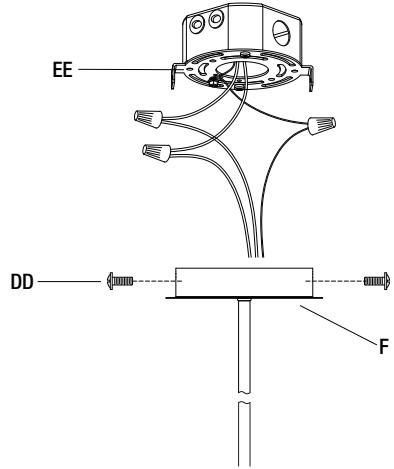

6 Installing the glass

- With reference to the line drawing, install the small glass (G) and large glass (H) to the fixture body (A) and twist clockwise to secure in place.

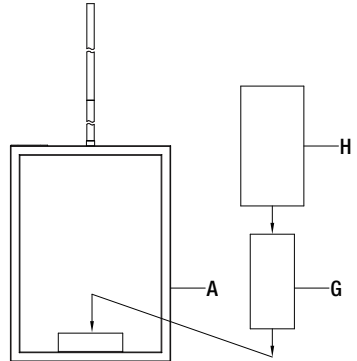

FCC Statement



WARNING: Changes or modifications to this unit not expressly approved by the party responsible for compliance could void the user's authority to operate the equipment.

NOTE: This equipment has been tested and found to comply with the limits for a Class B digital device, pursuant to Part 15 of the FCC Rules. These limits are designed to provide reasonable protection against harmful interference in a residential installation. This equipment generates, uses and can radiate radio frequency energy and, if not installed and used in accordance with the instructions, may cause harmful interference to radio communications. However, there is no guarantee that interference will not occur in a particular installation. If this equipment does cause harmful interference to radio or television reception, which can be determined by turning the equipment off and on, the user is encouraged to try to correct the interference by one or more of the following measures:

- Reorient or relocate the receiving antenna.
- Increase the separation between the equipment and receiver.
- Connect the equipment into an outlet on a circuit different from that to which the receiver is connected.
- Consult the dealer or an experienced radio/ TV technician for help.

Care and Cleaning

- Clean the light fixture carefully with a soft, dry cloth. Do not use any cleaners with chemicals, solvents, or harsh abrasives.

Troubleshooting

Problem	Possible Cause	Solution
<input type="checkbox"/> The bulb will not light.	<input type="checkbox"/> The bulb is burned out.	<input type="checkbox"/> Replace the light bulb.
	<input type="checkbox"/> The power is off.	<input type="checkbox"/> Ensure that the power supply is turned on.
	<input type="checkbox"/> The circuit breaker is off.	<input type="checkbox"/> Ensure that the circuit breaker is set to the ON position.
<input type="checkbox"/> The fuse blows or the circuit breaker trips when the light is turned on.	<input type="checkbox"/> There are too many items on one circuit.	<input type="checkbox"/> Unplug the other items on the circuit. <input type="checkbox"/> Contact a qualified electrician or call the Customer Service Team at 1-800-986-3460.

HOME DECORATORS COLLECTION

Questions, problems, missing parts? Before returning to the store,
call Home Decorators Collection Customer Service
8 a.m. - 7 p.m., EST, Monday – Friday, 9 a.m. - 6 p.m., EST, Saturday

1-800-986-3460

WWW.HOMEDEPOT.COM/HOMEDECORATORS

Retain this manual for future use.