

LawnMaster®

Operators Manual / Manuel D'utilisation

EN p. 2

19" 60V MAX* Lithium-Ion Cordless Mower CLMFT6018A

FR p. 37

Tondeuse Sans Fil CLMFT6018A 60V MAX* 480mm (19 po)

APPROVED

By Ben Means at 2:38 pm, Mar 10, 2017

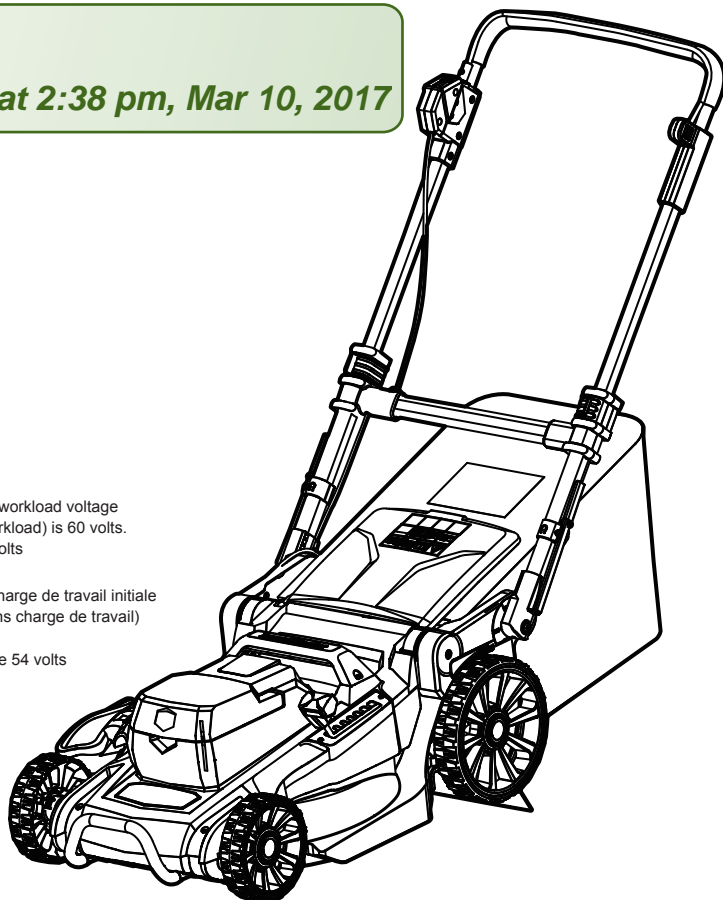

* Maximum initial battery workload voltage (measured without a workload) is 60 volts. Nominal voltage is 54 volts

* Tension batterie de la charge de travail initiale maximale (mesurée sans charge de travail) est de 60 volts. Tension nominale est de 54 volts

MNL_CLMFT6018A_V1



Read all safety rules and instructions carefully before operating this tool.

Distributed By Cleve North America 601 Regent Park Court Greenville, SC 29607 (866)-384-8432



Lisez attentivement toutes les consignes de sécurité ainsi que les instructions avant de faire fonctionner cet outil.

Distribué par Cleve North America 601 Regent Park Court Greenville, SC 29607 (866)-384-8432

TABLE OF CONTENTS

TABLE OF CONTENTS	2
SPECIFICATIONS	2
INTRODUCTION	3
GENERAL SAFETY RULES	3-5
SPECIFIC SAFETY RULES	6-8
SYMBOLS	9-10
FEATURES	11-13
ASSEMBLY	13-20
OPERATION	21-23
BATTERY PACK AND CHARGER	23
MAINTENANCE	24-30
ENVIRONMENTAL SAFE BATTERY DISPOSAL	31
TROUBLESHOOTING	32
LawnMaster® 60V WARRANTY	33
EXPLODED VIEW / PARTS LIST	34-35
NOTES	36

SPECIFICATIONS

60V CORDLESS MOWER

Battery Type	60V MAX* Lithium-Ion, 5.0Ah
No-load Speed	3200 r/min
Deck Width	19 inch (48cm)
Cutting Width	18 Inch (46cm)
Height Adjustments	7 Positions (1"-3.4") (25-85mm)
Functions	3-in-1: Mulch, Rear Bag, Side Discharge
Wheel Size	6.70" (170mm) / 9.25" (235mm)
Unit Weight (With 5.0Ah Battery)	42.8 Lbs (19.4kg)

* Maximum initial battery workload voltage (measured without a workload) is 60 volts.
Nominal voltage is 54 volts

CHARGER

Model No	60LFC02-ETL
Rated Input Voltage	120V ~ 60Hz
Rated Output	60V DC
Rated Output Current	4A
Charging Time	85min (For 60LB5025-S)

INTRODUCTION

This product has many features for making its use more pleasant and enjoyable. Safety, performance, and dependability have been given top priority in the design of this product making it easy to maintain and operate.

GENERAL SAFETY RULES

WARNING

This symbol indicates important safety instructions. If these instructions are not followed, it could endanger the personal safety and/or property of the operator and others. Read and understand all instructions in this manual before attempting to operate the mower. Failure to comply with these instructions may result in personal injury.

DANGER

This mower was built to be operated according to the rules for safe operation that are contained in this manual. As with any type of power equipment, carelessness or error on the part of the operator can result in serious injury. This mower is capable of amputating body parts and throwing objects. Failure to observe the following safety rules could result in serious injury or death.

WARNING

Use of this mower should be restricted to individuals who have read and understood and will follow the warnings and instructions that are printed in this manual and on the mower.

- Carefully read all instructions on the mower and in the manual before attempting to assemble and operate the mower. Keep this manual in a safe place for future reference, and consult it regularly.
- Do not use the lawn mower in damp or wet conditions or operate in the rain.
- Become familiar with all controls and their proper operation. Know how to stop the mower and how to disengage the power in an emergency.
- In order to avoid contact with the blade or injury caused by a thrown object, stay in the operating zone behind the handles, and keep children and bystanders at least 50 ft. (15 m) away from the mower while it is in operation. Stop the motor immediately if someone enters the mowing area.
- Thoroughly inspect the area where the mower is to be used. Remove all stones, sticks, wire, bones, toys, and other objects that could be tripped over or thrown by the blade. Thrown objects can cause serious personal injury.

GENERAL SAFETY RULES

- Plan your mowing pattern in such a way as to avoid discharging material toward roads, sidewalks, bystanders, etc. Do not discharge material against a wall or obstruction. Doing so may cause the discharged material to ricochet back toward the operator.
- Always wear proper eye protection in order to protect your eyes while operating or performing any adjustment or repair. Thrown objects that ricochet can cause serious eye injury.
- Always wear safety glasses with side shields. Everyday glasses have only impact resistant lenses. They are NOT safety glasses. Following this rule will reduce the risk of eye injury. Use face mask if operation is dusty.
- Wear safety glasses or goggles that are marked to comply with ANSI Z87.1 standard when operating this product.
- Always wear a face mask or a dust mask when operating the mower in a dusty environment.
- Dress properly. Do not wear loose clothing or jewelry that can get caught in moving parts. The wearing of protective gloves and safety footwear is recommended.
- Many injuries occur as a result of the mower being pulled over the operator's foot during a fall caused by slipping or tripping. Do not operate this mower in bare feet, or while wearing sandals or lightweight (e.g., canvas) shoes. Do not hold on to the mower if you are falling. Release the handle immediately.
- Never pull the mower back toward you while you are walking. If you must back the mower away from a wall or an obstruction, first look down and behind in order to avoid tripping, and then follow these steps:
 - Step back from the mower in order to fully extend your arms.
 - Be sure that you are well balanced.
 - Pull the mower back slowly.
- Do not use the mower for any job except that for which it is intended. Do not force the mower.
- Do not operate the mower while under the influence of alcohol or drugs.
- Stay Alert: Do not operate the mower when you are tired. Pay attention to what you are doing. Use common sense.
- Do not put hands or feet near rotating parts or under the cutting deck. Contact with the blade can amputate hands and feet.
- Keep hands and feet away from cutting area.
- Do not attempt to adjust the wheels or the cutting height while the motor is running.
- Avoid dangerous environments. Do not operate the mower in the rain or in wet or damp grass.
- Mow only in daylight or in good artificial light. Do not rush a mowing job.
- Stop the blade when crossing gravel driveways, walkways, or roads.
- If the mower starts to vibrate excessively, stop the motor and check for the cause immediately. Vibration is generally a warning of trouble.
- Stop the motor and wait until the blade comes to a complete stop before removing the collection bag or unclogging the chute. The cutting blade will continue to rotate for a few seconds after the motor is shut off. Do not place any part of your body in the blade area until you are sure that the blade has stopped rotating.

GENERAL SAFETY RULES

- Never operate mower without a proper trail shield, discharge cover, collection bag, switch control, or other safety device in place and in working order. Do not operate the mower with damaged safety devices. Doing so can result in injury.

CHILD SAFETY

- Tragic accidents can occur if the operator is not aware of the presence of children.
- Keep children out of the mowing area and under the watchful care of a responsible adult.
- Do not allow children under the age of 14 to operate this mower. Children who are 14 years of age and older must read and understand the operating instructions and safety rules in this manual, and must be trained and supervised by a parent.
- Stay alert, and turn the mower off if a child or any other person enters the mowing area.
- Look behind and down for small children before and while moving backwards.
- Use extreme care when approaching blind corners, doorways, shrubs, trees, or other objects that may obscure your view of a child who may run into the path of the mower.

CAUTION

USE ONLY LawnMaster® APPROVED REPLACEMENT BATTERIES, OTHER BATTERIES
MAY CAUSE INJURY OR DAMAGE TO THE MOWER.

Use with LawnMaster® 60V Lithium-Ion battery.

SPECIFIC SAFETY RULES

BATTERY SAFETY RULES

- Battery tools do not have to be plugged into an electrical outlet; therefore, they are always in operating condition. Be aware of possible hazards when not using your battery tool or when changing accessories. Following this rule will reduce the risk of electric shock, fire, or serious personal injury.
- Do not place battery tools or their batteries near fire or heat. This will reduce the risk of explosion and possibly injury.
- Do not crush, drop or damage battery pack. Do not use a battery pack or charger that has been dropped or received a sharp blow. A damaged battery is subject to explosion. Properly dispose of a dropped or damaged battery immediately.
- Batteries can explode in the presence of a source of ignition, such as a pilot light. To reduce the risk of serious personal injury, never use any cordless product in the presence of open flame. An exploded battery can propel debris and chemicals. If exposed, flush with water immediately.
- Do not charge battery tool in a damp or wet location. Following this rule will reduce the risk of electric shock.
- For best results, your battery tool should be charged in a location where the temperature is more than 45°F but less than 104°F. To reduce the risk of serious personal injury, do not store outside or in vehicles.
- Under extreme usage or temperature conditions, battery leakage may occur. If liquid comes in contact with your skin, wash immediately with soap and water. If liquid gets into your eyes, flush them with clean water for at least 10 minutes, then seek immediate medical attention. Following this rule will reduce the risk of serious personal injury.
- When battery pack is not in use, keep it away from other metal objects like: paper clips, coins, keys, nails, screws, or other small metal objects that can make a connection from one terminal to another. Shorting the battery terminals together may cause sparks, burns, or a fire.
- Always remove battery pack from your tool when you are assembling parts, making adjustments, cleaning, or when not in use. Removing battery pack will prevent accidental starting that could cause serious personal injury.
- Always remove battery pack before storing the device. When battery becomes fully charged, unplug the charger from the power supply and remove the battery pack from the charger.
- Always wear eye protection with side shields marked to comply with ANSI Z87.1, along with hearing protection. Failure to do so could result in objects being thrown into your eyes and other possible serious injuries.
- Keep battery pack dry, clean, and free from oil and grease. Always use a clean cloth when cleaning. Never use brake fluids, gasoline, petroleum-based products, or any solvents to clean battery pack.

SPECIFIC SAFETY RULES

BATTERY & CHARGER

CAUTION

USE ONLY LawnMaster® APPROVED REPLACEMENT BATTERIES, OTHER BATTERIES MAY CAUSE INJURY OR DAMAGE TO THE MOWER. Use with LawnMaster® 60V Lithium-Ion battery.

Ensure that the device is switched off before inserting the battery. Inserting a battery into a power tool that is switched on may result in accidents.

Recharge the batteries indoors only because the battery charger is designed for indoor use only. To reduce the electric shock hazard, unplug the battery charger from the outlet before cleaning the charger.

Do not subject the battery to strong sunlight over long periods and do not leave it on a heater. Heat damages the battery and there is a risk of explosion.

Allow a hot battery to cool before charging.

Do not open up the battery and avoid mechanical damage to the battery. Risk of short circuit and fumes may be emitted that irritate the respiratory tract. Ensure fresh air and seek medical assistance in the event of discomfort.

Do not use non-rechargeable batteries!

The device must not be used by people (including children) with limited physical, sensory or mental faculties or who lack the necessary experience and/or knowledge - other than they are supervised by a person responsible for safety or are being instructed to operate the appliance by such a person. Children must be supervised in order to ensure that they do not play with the equipment.

To charge the battery, use only the charger supplied. Risk of fire and explosion. This ensures that the safety of the device is maintained.

Before each use, check the charger, cable and plug and have them repaired by qualified professionals and only with original parts. Do not use a defective charger and do not open it up yourself. This ensures that the safety of the device is maintained.

Connect the charger only to a socket that is grounded. Ensure that the outlet voltage matches specifications on the charger rating plate. Risk of electric shock.

Disconnect the charger from the outlet before closing or opening connection to the battery / power tool /device.

Keep the charger clean and away from wet and rain. Do not use the charger outdoors. Dirt and the entry of water increase the risk of electric shock.

Operate the charger only with the appropriate original batteries. Charging other batteries may result in injuries and risk of fire.

Avoid mechanical damage to the charger. This can result in internal short circuits.

SPECIFIC SAFETY RULES

Do not operate the charger on a combustible surface (e.g. paper, textiles). Risk of fire due to heating during charging.

If the power cord for this equipment is damaged, it must be replaced by the manufacturer, a customer service agent of the same or qualified person in order to prevent hazards.

The battery of the appliance is not fully charged at the time of delivery. It therefore needs to be fully recharged before you use it for the first time. For the first recharge cycle, charge the battery pack fully. Slot the battery into the base and plug the battery charger into an outlet.

When the battery is fully charged, unplug the charger from the outlet and from the appliance. Charging time is approx. 85 min.









Do not charge the battery continuously since this may damage the battery cells.

NOTE: Repeatedly charging small capacities may damage the battery cells. Recharge the battery only if the appliance is becoming slow.





Do not use the charger to charge non-rechargeable batteries.

SYMBOLS



Some of the following symbols may be used on this product. Please study them and learn their meaning. Proper interpretation of these symbols will allow you to operate the product better and safer.

SYMBOL	NAME	DESIGNATION/EXPLANATION
V	Volts	Voltage
---	Direct Current	Type or a characteristic of current
A	Amperes	Current
Hz	Hertz	Frequency (cycles per second)
W	Watt	Power
hrs	Hours	Time
	Class II Construction	Double-insulated construction
	Safety Alert	Precaution that involves your safety.
	Read The Operator's Manual	You must read the operating instructions carefully.
	Do not mow up and down slopes!	To avoid the risk of injury do not mow up and down slopes. Always mow across slopes. (Angle $\leq 15^\circ$)
	Keep all persons and pets at a safe distance from the mower while operating!	To avoid the risk of injury to bystanders keep all persons and pets at a safe distance from the mower while operating.
	Keep hands and feet clear of mower deck and discharge opening at all times!	Rotating blades can cause serious injury. Keep hands and feet clear of mower deck and discharge opening at all times. Always be sure blade has stopped after releasing switch lever and unplugging before removing and replacing collection bag, cleaning, servicing, transporting or lifting the mower.
	Stay behind the handle when the motor is running!	Objects struck by mower blade can cause serious injury. Stay behind the handle when the motor is running. Always ensure persons and pets are clear of the discharge from the mower while operating.
	Wear hearing and eye protection when operating this equipment.	Safety Alert Precautions that involve your safety.

SYMBOLS

	Lithium-Ion Battery Recycling	Designates that this tool is in compliance with Lithium-Ion battery recycling program requirements
	Keep Away From Water	Do not dispose of battery packs in rivers or immerse in water
	Keep Away From Fire	Do not dispose of battery packs in fire. They will explode or leak and cause injury.
	Heat Alert	Do not expose battery packs to heat in excess of 60°C (140°F).
	Recycle Symbol	This product uses lithium-ion batteries. Local, state, or federal laws may prohibit disposal of batteries in ordinary trash. Consult your local waste authority for information regarding available recycling and/or disposal options.

The following signal words and meanings are intended to explain the levels of risk associated with this product.

SYMBOL	SIGNAL	MEANING
	DANGER:	Indicates an imminently hazardous situation, which, if not avoided, will result in death or serious injury.
	WARNING:	Indicates a potentially hazardous situation, which, if not avoided, could result in death or serious injury.
	CAUTION:	Indicates a potentially hazardous situation, which, if not avoided, may result in minor or moderate injury.
	CAUTION:	(Without Safety Alert Symbol) Indicates a situation that may result in property damage.

SERVICE

Servicing requires extreme care and knowledge and should be performed only by a qualified service technician. For service we suggest you return the product to your nearest SERVICE CENTER for repair. When servicing, use only identical replacement parts.

WARNING

To avoid serious personal injury, do not attempt to use this product until you read thoroughly and understand completely the operator's manual.

If you do not understand the warnings and instructions in the operator's manual, do not use this product. Call customer service for assistance (866-384-8432).

WARNING

 The operation of any power tool can result in foreign objects being thrown into your eyes, which can result in severe eye damage. Before beginning power tool operation, always wear safety goggles or safety glasses with side shields and, when needed, a full face shield.

We recommend Wide Vision Safety Mask for use over eyeglasses or standard safety glasses with side shields. Always use eye protection which is marked to comply with ANSI Z87.1.

FEATURES

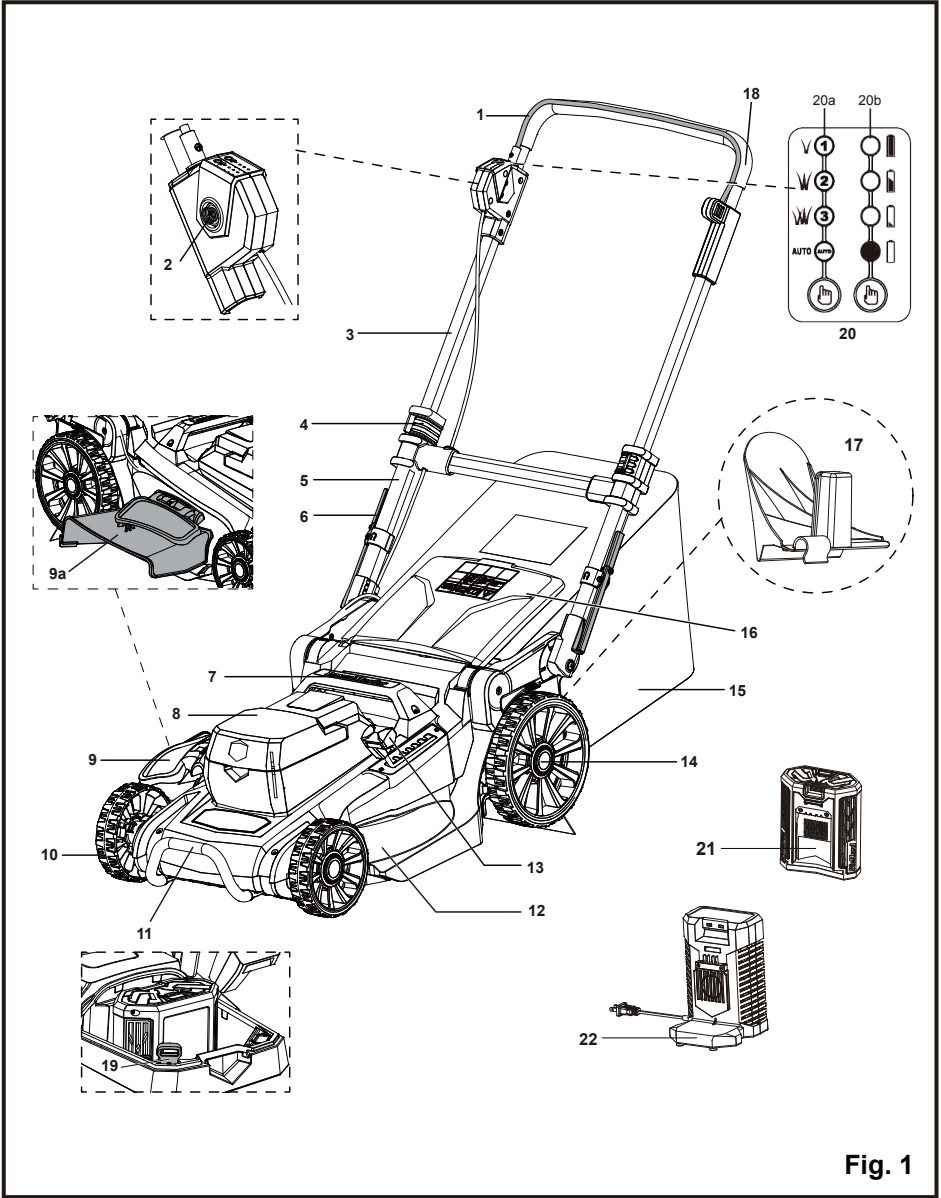

Fig. 1

FEATURES

KNOW YOUR LAWN MOWER (See Fig 1)

The safe use of this product requires an understanding of the information on the product and in this operator's manual as well as a knowledge of the project you are attempting.

Before use of this product, familiarize yourself with all operating features and safety rules.

- | | |
|-------------------------------|---|
| 1. Start/stop Bale Switch | 13. Cutting Height Adjustment Lever |
| 2. Safety Switch Button | 14. Rear Wheels |
| 3. Upper Handle Bar | 15. Collection Bag |
| 4. Handle Locking Clips X2 | 16. Safety Flap |
| 5. Lower Handle Bar | 17. Mulching Plug |
| 6. Locking Levers X2 | 18. Foam Grip |
| 7. Mower Carry Handle | 19. Safety Key
(Inside the Battery Pack Compartment) |
| 8. Battery Compartment Cover | 20. iPower Control Panel |
| 9. Side Discharge Door | 20a. iPower Mower Mode Indicator |
| 9a. Side Discharge Chute | 20b. iPower Battery Meter Indicator |
| 10. Front Wheels | 21. Battery Pack |
| 11. Front Bumper Guard/Handle | 22. Battery Charger |
| 12. Deck | |

NOTE: the above parts and their associated number/letters will be used throughout this manual to identify parts.

Unpack

This product requires assembly.

- Carefully remove the product and any accessories from the box. Make sure that all items listed in the packing list are included (p,13). Look under the interior bottom carton flaps for any missing small items.
- Inspect the product carefully to make sure no breakage or damage occurred during shipping.
- Do not discard the packing material until you have carefully inspected and satisfactorily operated the product.
- If any parts are damaged or missing, please call 866-384-8432.

YOU WILL NEED (ITEMS NOT SUPPLIED)

- Screwdriver, flat head
- Suitable personal protective equipment

FEATURES

PACKING LIST

Mower

Safety Key (Attached inside the Battery Pack Compartment of Mower)

Mulching Plug - Comes installed from factory at rear of mower

Grass Collection Bag Assembly (Bag & Metal Frame)

Side Discharge Chute

Battery Charger

60V Lithium-Ion Battery

Operator's Manual

Handle Operation Card (Attached to the Mower)

NOTE: The safety key must be installed for mower to operate. The safety key only fits into the switch in one direction. **DO NOT FORCE IT!**

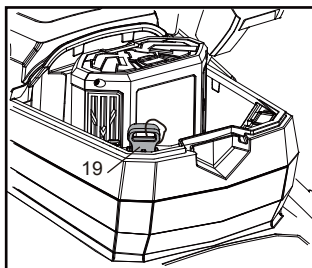

ASSEMBLY

⚠ WARNING

If any parts are damaged or missing do not operate this product until the parts are replaced. Failure to heed this warning so could result in serious personal injury.

Do not attempt to modify this product or create accessories not recommended for use with this product. Any such alteration or modification is misuse and could result in a hazardous condition leading to possible serious personal injury.

Do not connect power supply until assembly is complete. Failure to comply could result in accidental starting and possible serious personal injury.

Never operate the mower without the proper safety devices in place and working. Never operate the mower with damaged safety devices. Failure to heed this warning can result in serious personal injury.

ASSEMBLY

ASSEMBLING THE COLLECTION BAG (See Figs. 2-3)

Your LawnMaster® mower comes with a tool-less collection bag.

To assemble:

- Check the collection bag before assembling to make sure there is no damage.
- Pull the collection bag over the steel frame as shown.
- Pry open the soft plastic clamping sleeves with your fingers and insert the steel frame into the sleeves as shown. Ensure all sleeves are properly clamped with your fingers on the frame.
- The completely assembled collection bag is shown as below.

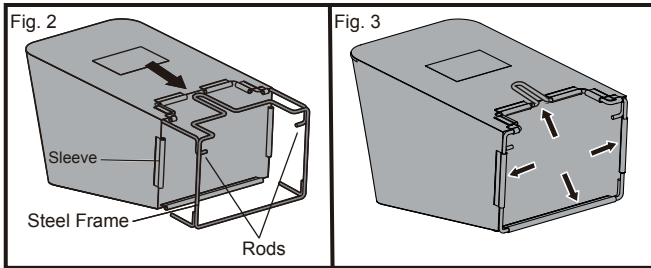

INSTALLING THE COLLECTION BAG (See Fig. 4)

NOTE: When using the collection bag, do not install the mulching plug (17). Mulching plug **MUST** be removed prior to installing collection bag.

- Lift the rear safety flap (16) and hold it in position.
- Lift the collection bag by its handle, hook the rods of collection bag on the mower holder under rear safety flap.
- Release the rear safety flap.
- Make sure both rods are firmly seated on the holder and rear safety flap (16) rests firmly against the top of the collection bag.

NOTE: Under normal usage, bag material is subject to wear. To reduce the risk of injury, frequently inspect the bag assembly and replace if there are any signs of wear or deterioration.

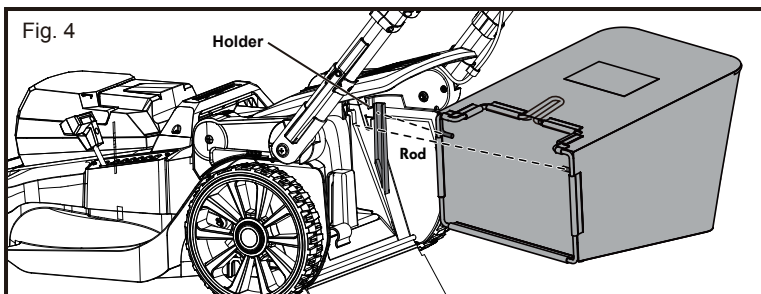

ASSEMBLY

INTENDED USE

This cordless lawnmower is designated with LawnMaster® 60V Lithium-Ion batteries.

The product is intended for mowing and mulching grass in domestic yards only. It must not be used for mowing unusually high, dry or wet grass, e.g. pasture grass, or for shredding leaves.

This product is intended for private domestic use only, not for any commercial trade use. It must not be used for any purposes other than those described.

HANDLE BAR TILT ADJUSTMENT

The working position is for operating the product. Just install the battery pack and operate it in this position.

The parking position is an intermediate position, which is used to empty the collection bag. Stop the machine and remove the battery pack before switching to this position.

The storage position is used to store the product in a space-saving manner when not in use. Stop the machine and remove the battery pack before switching to this position.

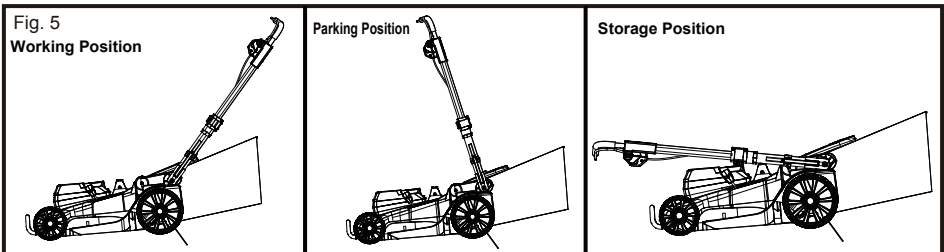

- When the product is purchased, out of the box the handle bar is in its storage position.
- Press and hold the locking levers (6) on both sides of handle bar with both your hands to release handle bar from locked position, then rotate the handle to switch into desired position. Gently pivot the handle until you hear and feel the locking pin engage in desired position.
- Release the levers. Make sure they are locked into place.

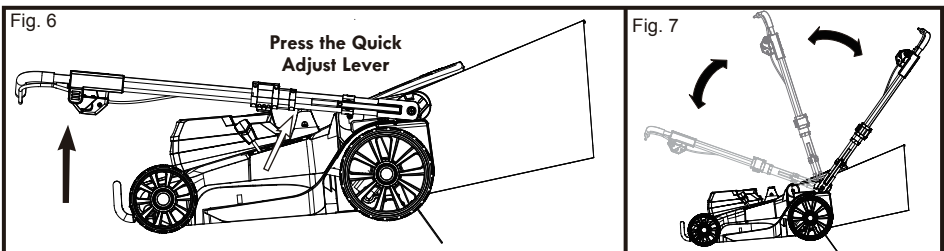

ASSEMBLY

HANDLE BAR HEIGHT ADJUSTMENT (See Figs. 8-9)

To adjust height for working:

- Rotate handle bar into working position.
- Adjust handle bar to the extreme working position by pulling it up, then close the locking clips (4).
- Before operating the machine, make sure the handle bars are locked into place with the pins of locking clips (4) inserted into holes on the bar.

To adjust height for storage:

- Unlock both locking clips, then push down the handle bar to the lower position.
- Press and hold the locking levers (6) on both sides of handle bar with both hands to release handle bar from locked position, then pivot the handle bar all the way to storage position. Gently pivot the handle until you hear and feel the locking pin engage in storage position (Figs. 6-7).

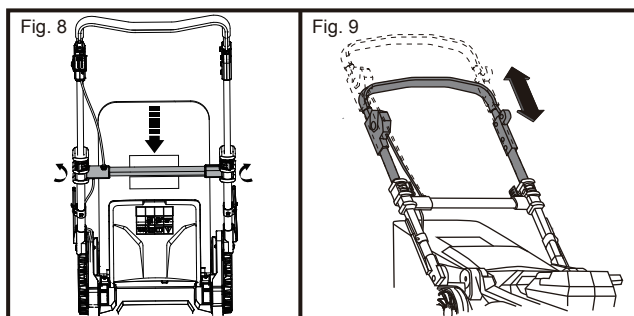

SETTING CUTTING HEIGHT (See Fig. 10)

⚠ WARNING

Do not at any time make any adjustment to the lawn mower without first stopping the motor and removing the safety key. Keep your feet away from the deck when adjusting its height.

When shipped, the rear wheels (14) on the mower are set to a low-cutting position. Before using the mower for the first time, adjust the cutting position to the height best suited for your lawn. The mower can be set to 7 cutting heights between 1" (25mm) and 3.4" (85mm). 7 is the highest setting, 1 is the lowest. Choose the proper cutting height according to the types and conditions of the grass. To set the cutting height:

- To raise the cutting height, grasp the cutting height adjustment lever (13), then move it toward the back of the mower and engage the lever in the desired cutting height position on the mower deck.
 - To lower the cutting height, grasp the cutting height adjustment lever (13), then move it toward the front of the mower and engage the lever in the desired cutting height position on the mower deck.
-

ASSEMBLY

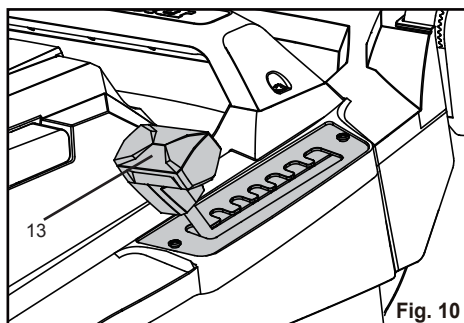

COLLECTION BAG VIEW WINDOW (See Fig. 11)

- The collection bag (15) is equipped with a clear view window through which user can observe the filling condition during the mowing process.
- Empty the collection bag in time when there is a sign that collection bag is full or nearly full by observing the view window.

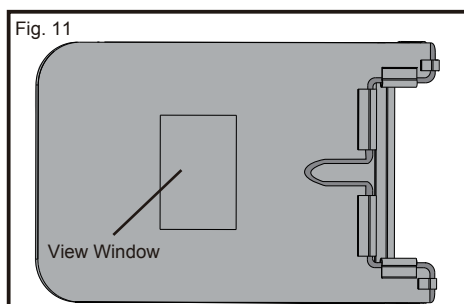

EMPTYING

- Lift the collection bag by its handle and lift to remove from mower.
- Empty grass clippings.
- Lift the safety flap (16) and reinstall the collection bag as described earlier in this manual.

ATTACHING/REMOVING THE MULCHING PLUG

WARNING

Do not at any time make any adjustment to the lawn mower without first stopping the motor and removing the safety key (19). Do not attach the collection bag (15) and the mulching plug (17) at the same time.

ASSEMBLY

NOTE: Mulch plug **MUST** be removed if collection bag is used during mowing operation. The mulching plug (17) prevents grass from being collected by blocking the collection chute. This allows the grass clippings to be deposited back on the lawn during cutting.

- Lift the safety flap (16) and detach the grass collection bag.
- Open the safety flap (16), hold it in position and insert the mulching plug into the rear discharge chute (Fig. 12). Ensure the locking button snaps into place, as picture shown (Fig. 13).
- Press the locking button to release and remove the mulching plug (Fig. 14).

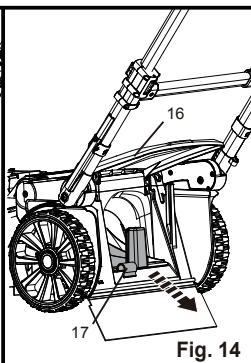
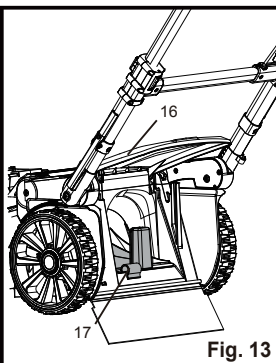
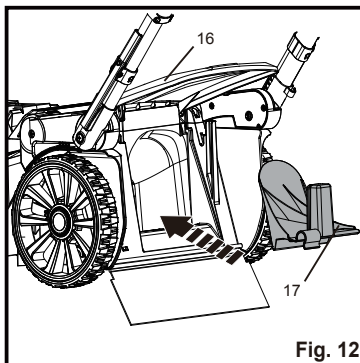

INSTALLING THE SIDE DISCHARGE CHUTE (See Fig. 15)

⚠ WARNING

Do not at any time make any adjustment to the lawn mower without first stopping the motor and removing the safety key (19).

The mower is designed to disperse the clippings back to the lawn. Pull up the side discharge door and insert the side discharge chute. The side discharge is optional, if you do not need, you can take it away.

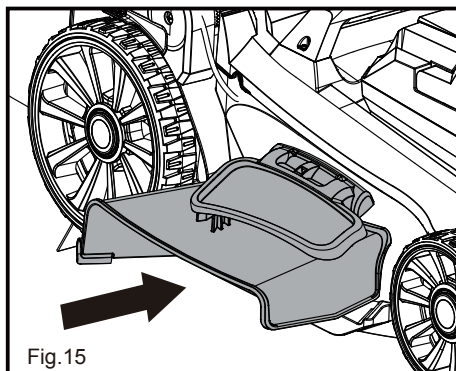

ASSEMBLY

INSTALLING / REMOVING THE BATTERY PACK

⚠ WARNING

If any parts are broken or missing, do not attempt to attach the battery pack to the mower or operate the mower until the broken or missing parts are replaced. Failure to do so could result in serious injury. Do not connect the battery and/or the safety key before the product is completely assembled.

To install battery pack:

- Open the plastic battery compartment cover (8) at front of mower.
- Align the raised ribs on the mower with the grooves in the battery pack (21), and then insert the battery pack into the compartment.
- Push the battery pack (21) until you hear a “click”.
- Close the battery compartment cover (8).
- Your product is now ready to be used.

NOTE: Make sure that battery pack firmly snaps into place and is secured to the mower before starting operation.

To remove battery pack:

- Stop the machine. Lift the battery compartment cover (8) and remove the safety key (19).
- Press the release button on the battery pack (21), grasp the battery pack firmly and pull out of the battery compartment (Fig. 16).
- Close the battery compartment cover (8) (Fig. 17).

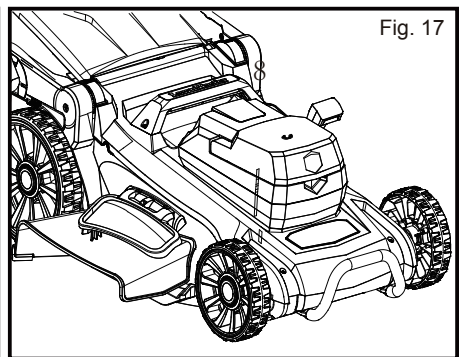
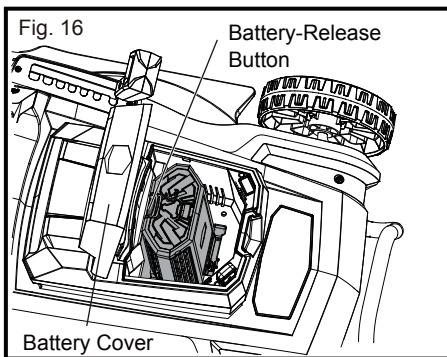

ASSEMBLY

iPOWER MOWER MODE INDICATOR (20a) (See Fig. 18)

Located on upper mower handle

- By default, the motor power is set to “AUTO” and will automatically adjust to your lawn.
- Push the press button repeatedly to cycle through the different motor power levels.
 - Set the motor power to “1”, if your lawn needs only light mowing.
 - Set it to “2”, if you are going to mow taller and thicker grass.
 - Set it to “3” to utilize the maximum motor power for mowing the most stubborn grass.

iPOWER BATTERY METER INDICATOR (20b) (See Fig. 18)

- Push the press button to check on the battery status.
- The number of lights lit will depend on the condition of the battery.
- 4 lights indicate a fully charged battery, 1 light indicates the battery needs to be charged.

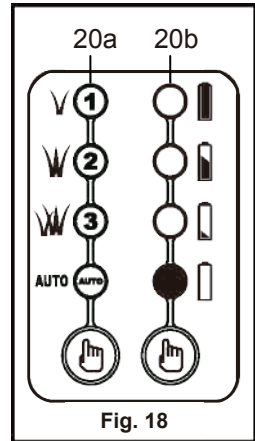

iPower Control Panel (20)

⚠ WARNING

A flashing LED on the cutting mode control panel indicates that the current is too high. A flashing LED on the battery indicates that the voltage is too low. In either case the motor will be shut down automatically. Do not continue to activate the On/Off switch if the motor has been shut down automatically. The battery may be damaged.

OPERATION

STARTING / STOPPING

- To switch on, insert the safety key (19), press and hold the safety switch button (2) and gently pull the start/stop bale switch (1) (Fig. 19-21). Once started, release the safety switch button (2).
- To power off the mower, release the start/stop bale switch (1). Pull out the safety key (19) if the mower is not going to be used immediately (Fig. 22).

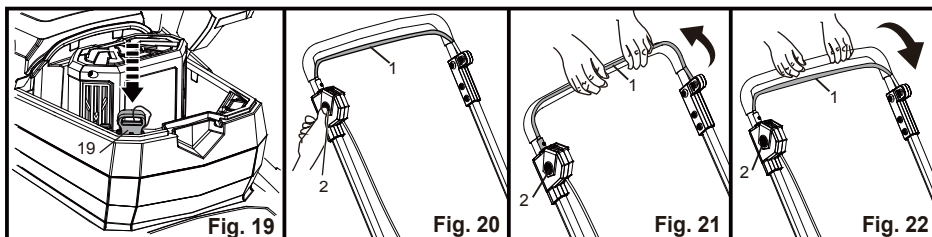

GENERAL OPERATION

Check the product, its power cord and accessories for damage before each use. Before use, please ensure all power connections are in good working order prior to installing the power key and battery. If damage is present or observed, please stop and have mower serviced before use. Do not use the product if it is damaged or shows wear.

- Double check that the blade is properly installed.
- Always hold the product by its handles. Keep the handles dry to ensure safe support.
- Ensure that the air vents are always unobstructed and clear. Clean them if necessary with a soft brush. Blocked air vents may lead to overheating and damage the product.
- Switch the product off immediately if you are disturbed while working by other people entering the working area. Always let the product come to complete stop before removing the grass collection box.
- Do not overwork yourself. Take regular breaks to ensure you can concentrate on the work and have full control over the product.

MOWING

- Make sure the lawn is clear of stones, sticks, wires, and other objects that could damage the lawn mower blades or motor. Such objects could be accidentally thrown by the mower in any direction and cause serious personal injury to the operator and others.
- For a healthy plot of grass, always cut off one-third or less of the total length of the grass.
- When cutting heavy grass; reduce walking speed to allow for more effective cutting and a proper discharge of the clippings.
- Do not cut wet grass. It will stick to the underside of the deck (12) and prevent proper mulching of grass clippings.
- New or thick grass may require a narrower cut.
- Clean the underside of the mower deck (12) after each use to remove grass clippings, leaves, dirt, and any other accumulated debris.

OPERATION

Mow in slight overlapping rows. The most effective pattern for mowing lawns is straight lines along one of the sides. This will keep the rows even and ensures that all the lawn is cut without missing any spots (Fig.23).

AFTER USE

- Switch the product off, remove the battery pack (21) and let it cool down.
- Check, clean and store the product as described below.

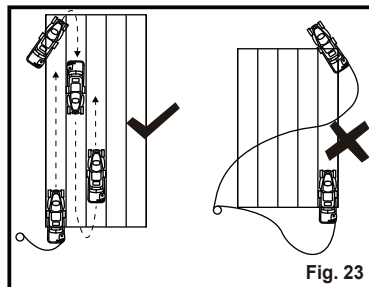

Fig. 23

BATTERY PACK AND CHARGER

BATTERY CHARGING

- Use only with 60V LawnMaster® battery chargers. The battery charger supplied is specifically designed for the Lithium-Ion battery used in this garden appliance.
- Check the power voltage! Battery chargers operate on 120 V.
- The battery is charged between 45°F and 104°F. This ensures an optimum battery service life.
- Protect the battery from heat, from continuous exposure to sun and keep away from radiation or other heat sources. Do not leave the battery in the mower in direct sunlight over long periods.
- The battery is supplied partially charged. To ensure full capacity of the battery, charge the battery before using your appliance for the first time. The Lithium-Ion battery can be charged at any time without reducing its service life. Interrupting the charging procedure does not affect the battery.
- Always leave it fully charged if kept in the charger for storage.





CHARGER LEDS

- If the battery is not inserted, a **continuous red LED light** indicates that the outlet plug is plugged into a outlet socket and the battery charger is ready for operation.
- Charging: a **flashing green LED** on the charger indicates that the battery is charging normally.
- Charged: **continuous green LED** on the charger indicates that the battery is ready for use.
- Technical Issue: a **flashing red LED light** on the charger indicates that battery pack has a charging problem or might be defective.
 - One possible condition is the battery temperature is not within the charging temperature range of 45°F - 104°F or the charging current is too high. As soon as the permitted temperature and the charging current ranges are reached, the battery charger will automatically switch to charging.

OPERATION

- If the temperature range and charging current are correct and flashing red LED light continues, then remove and reinstall the battery pack. If the LED status repeats a second time, try to charge another identical battery. If the battery charges normally, dispose of the defective battery pack (see Environmental Safe Battery Disposal section).
- If the flashing red light continues after installing the second battery, the charger may be defective. Replace with a new one.
- After continuous or repeated charging cycles without interruption, the charger may warm up. This is normal and does not indicate a technical defect of the battery charger.

The indicator lights on the charger show the charger status:

SYMBOL	INDICATOR LIGHTS	STATUS
	Red, continuous	Connected to power supply
	Green, blinking	Charging
	Green, continuous	Fully charged
	Red, blinking	Charging problem: See Technical Issue

BATTERY PACK AND CHARGER

BATTERY LED PANEL

- The panel consists of 2 LEDs on the battery. Press and release the button, the LEDs will show you the charge levels
- The battery's charge level can be checked either when the battery is attached on the machine or removed from the machine.

LEDs on battery (Continuous lighting)	Battery Capacity
Green	50%~100%
Orange	25%~ 50%
Red	0-25% (Recharge required)

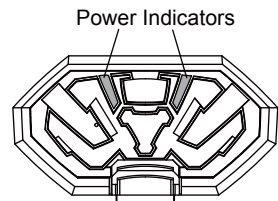

MAINTENANCE

WARNING

When servicing, use only identical replacement parts. Use of any other parts may create a hazard or cause product damage.

WARNING

Always wear safety goggles or safety glasses with side shields during power tool operation or when blowing dust. If operation is dusty, also wear a dust mask.

GENERAL MAINTENANCE

Avoid using solvents when cleaning plastic parts. Most plastics are susceptible to damage from various types of commercial solvents and may be damaged by their use. Use clean cloths to remove dirt, dust, oil, grease, etc.

WARNING

Do not use any attachments or accessories not recommended by the manufacturer of this product. The use of attachments or accessories not recommended can result in serious personal injury.

- Do not at any time make any maintenance to the lawn mower without first stopping the motor and removing the safety key and battery pack. Adjust the handle bar or make other adjustments as illustrated in the manual, if necessary or if it can make it easier for maintenance.
- Periodically check all nuts and bolts for proper tightness to insure safe operation of the mower.
- Remove any buildup of grass and leaves on or around the motor cover. Wipe the mower clean with a dry cloth occasionally. Do not use water.

LUBRICATION

All of the bearings in this product are lubricated with a sufficient amount of high grade lubricant for the life of the unit under normal operating conditions. Therefore, no further bearing lubrication is required. At the beginning and end of each mowing season:

- Lubricate the springs on the rear discharge door with light oil.
 - Lubricate the cutting height adjustment lever (13) and related hardware with light oil.
 - Remove the wheels and lubricate the surface of the axle bolt and the inner surface of the wheels with light oil.
 - Remove the blade and blade hub assembly and lubricate the motor shaft with light oil or engine oil. See Replacing the Cutting Blade for instructions on removing the blade.
-

MAINTENANCE

⚠ WARNING

Always protect hands by wearing heavy gloves and/or wrapping the cutting edges of the blade with rags and other material when performing blade maintenance. Failure to heed this warning could result in serious personal injury.

⚠ WARNING

Before performing any maintenance, make sure the mower is unplugged from the power supply and battery has been removed. Failure to heed this warning could result in serious personal injury.

REPLACING THE MOWER BLADE (See Figs. 24-25)

NOTE: Remove safety key and battery before performing any maintenance!

NOTE: Only use identical replacement blades. LawnMaster® mower blade replacement part #RMB6018A.

- Stop the motor and allow the blade to come to a complete stop.
- With blade stopped, remove **SAFETY KEY** and **BATTERY** from mower and store in safe location.
- Remove collection bag from mower if attached.
- Slowly turn the mower onto its side.
- Wedge a block of wood between the blade and the mower deck (12) in order to prevent blade from turning while the blade nut is being removed.
- Loosen the blade nut using a wrench or socket (not provided).
- Remove the blade nuts counterclockwise, then remove the blade.
- Make certain the fan assembly is pushed completely against the motor shaft.
- Place the new blade on the shaft against the fan assembly. Make sure it is installed with the curved ends pointing up toward the mower deck (17) and not down toward the ground.
- Thread the blade nuts on the shaft and finger tighten.
- Torque the blade nuts down using a torque wrench (not provided) to 25 N•m (221.5 pound-inches) to ensure the bolt is properly tightened.

NOTE: Make certain all parts are replaced in the exact order in which they were removed.

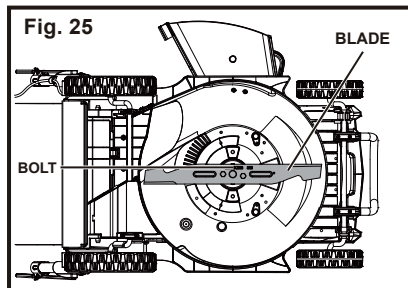
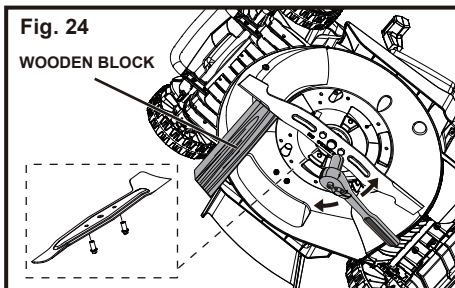

MAINTENANCE

SHARPENING THE BLADE (See Fig. 26)

For best mowing performance, the mower blade must be kept sharp. A dull blade does not cut grass evenly and overloads the motor. Under normal circumstances, sharpening the blade twice during the mowing season is usually sufficient. However, if your lawn has sandy soil, more frequent sharpening may be required.

- Following the instructions in the Replacing Mower Blade section (p. 25), remove the mower blade. DO NOT attempt to sharpen the blade while it is attached to the mower.
- Using a fine-tooth file or sharpening stone, sharpen cutting edges on both ends of the blade, removing equal amounts of material from both ends.

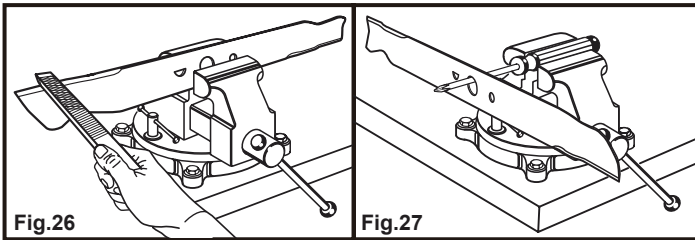

⚠ WARNING

When removing, inspect the blade carefully. If blade is bent or damaged, replace immediately with a new blade. Failure to replace a bent or damaged blade could cause an accident resulting in possible serious injury.

BALANCING THE BLADE (See Fig. 27)

When sharpening, care should be taken to keep the blade balanced. An unbalanced blade will cause excessive vibration when the mower is running. This vibration will eventually cause damage to the mower, especially the motor.

To check the blade balance:

- Clamp a screwdriver horizontally in a vise as shown.

NOTE: If a vise is not available, a straight nail can also be used.

- Place the center hole of blade on the screwdriver (or nail) shank.
- If blade is balanced, it will remain in a horizontal position. If either end of the blade drops downward, sharpen the heavy side until the blade is balanced.

MAINTENANCE

REPLACING WHEELS (See Fig. 28)

To replace a wheel (10 or 14):

NOTE: before replacing a rear wheel (14), set the mower at the highest position.

- Remove safety key (19) and battery (21) at first before replacing the wheel.
- Turn the mower upright.
- Push the inner hubcap tabs from inner side of the wheel, by using a flat head screwdriver or other adequate tool.
- When all inner hubcap tabs have been depressed, the hubcap should become free allowing access to the axle.
- Remove the cotter pin using a pair of pliers, and slide the washer off the axle.
- Remove the wheel, replace with a new identical replacement wheel.
- Reinstall the washer and press cotter pin back into place. Reinstall the inner hubcap. Make sure all tabs are locked into place.

NOTE: Servicing or replacing requires extreme care, knowledge and skills, and we suggest it be performed by a qualified service technician. You can return the product to your nearest **SERVICE CENTER** for repairing or replacing. When servicing, use only identical replacement parts.

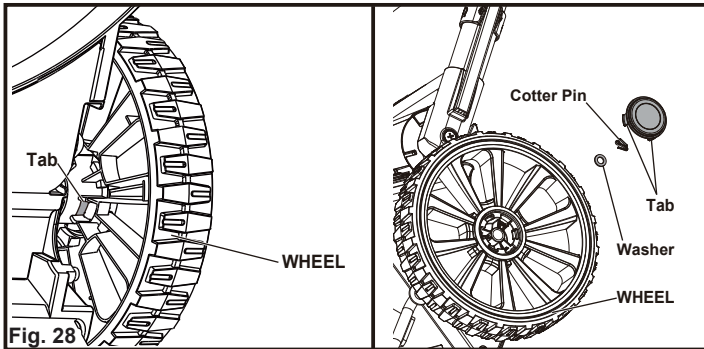

MAINTENANCE

STORING THE MOWER (See Fig. 29-34)

- Remove mower safety key (19) and battery.
- Turn mower on its side and clean grass clippings that have accumulated on the underside of the mower deck (12).
- Wipe the mower clean with a dry cloth.
- Check all nuts, bolts, knobs, screws, fasteners, etc., for tightness.
- Inspect moving parts for damage, breakage, and wear. Have repairs made on any damaged or missing parts.
- Store mower indoors in a clean, dry place out of the reach of children.
- Do not store near corrosive materials such as fertilizer or rock salt.

To lower the handle before storing:

- Unlock the locking clips on both sides of the handle bar, then push down the handle bar to the lower position (Fig. 29-30).

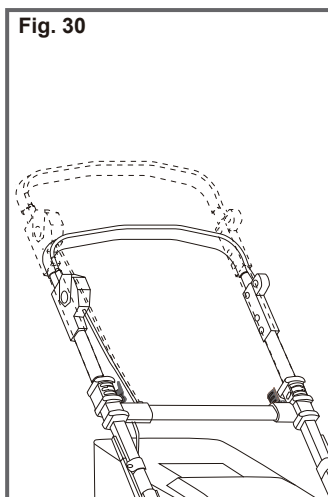
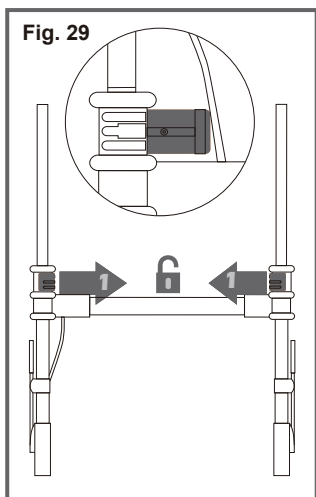

MAINTENANCE

- Press and hold the locking levers (6) on both sides of handle bar with both hands to release handle bar from locked position, then rotate the handle bar all the way to storage position. Gently pivot the handle until you hear and feel the locking pin engage in storage position.

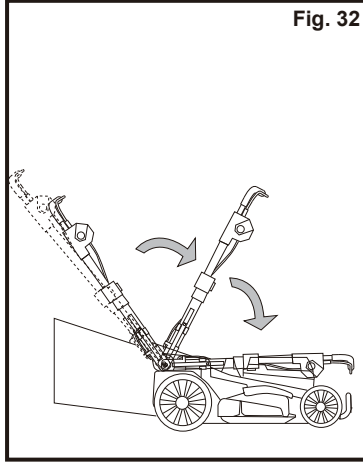
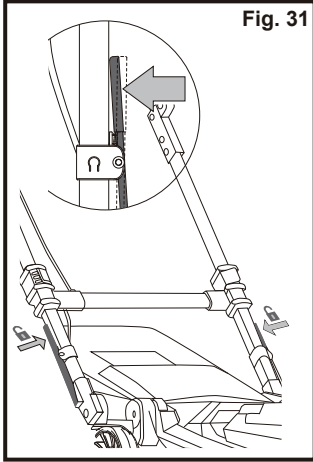

- Store the mower upright or flat (Fig. 33-34).

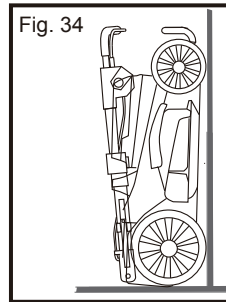
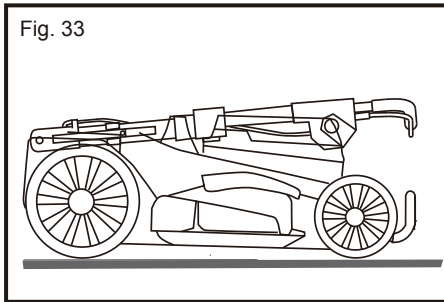

MAINTENANCE

CHARGER MAINTENANCE

- Keep the charger clean and clear of debris. Do not allow foreign material into the recessed cavity or on the contacts. Wipe with a dry cloth. Do not use solvents, water, or place in wet conditions.
- Always unplug the charger when there is no battery pack in it.
- Check that the charger contacts have not been shorted by debris or foreign material.

REPLACING THE BATTERY

The mower battery is designed for maximum life, however, like all batteries, will eventually need to be replaced.

Always charge new batteries before use.

To install a new battery:

- Remove the safety key (19).
- Carefully unlock and remove the battery pack (21).
- Install the new battery pack (21).
- Take the old battery pack to a recycling center that accepts lithium-ion batteries.

Never dispose of battery in fire or regular household trash.

CLEAN THE MOWER

WARNING

To reduce the risk of electric shock, do not expose the mower to water.

WARNING

Do not at any time make any maintenance to the lawn mower without first stopping the motor and removing the safety key and battery pack.

The underside of mower deck (12) should be cleaned after each use as grass clippings, leaves, dirt and other debris will accumulate causing rust and corrosion.

- Remove any buildup of grass and leaves on or around the motor cover (do not use water). Wipe the mower clean with a dry cloth occasionally.
- If debris build up on the underside of the unit while in use, stop the motor and remove the battery pack. Tilt the mower forward, or on its side, and clean.

ENVIRONMENTAL SAFE BATTERY DISPOSAL

The following toxic and corrosive materials are in the batteries used in this battery pack: **Lithium-Ion, a toxic material.**

WARNING

All toxic materials must be disposed of in a specified manner to prevent contamination of the environment. Before disposing of damaged or worn out Lithium-Ion battery packs, contact your local waste disposal agency, or the local Environmental Protection Agency for information and specific instructions.

WARNING

If the battery pack cracks or breaks, with or without leaks, do not recharge it and do not use. Dispose of it and replace with a new battery pack. **DO NOT ATTEMPT TO REPAIR IT!** To avoid injury and risk of fire, explosion, or electric shock, and to avoid damage to the environment:

- Cover the battery terminals with heavy-duty adhesive tape.
 - DO NOT attempt to remove or destroy any of the battery pack components.
 - DO NOT attempt to open the battery pack.
 - If a leak develops, the released electrolytes are corrosive and toxic.
DO NOT get the solution in the eyes or on skin, and do not swallow it.
 - DO NOT place these batteries in your regular household trash.
 - DO NOT incinerate.
 - DO NOT place batteries where they will become part of any waste landfill or municipal solid waste stream.
 - Take batteries to a certified recycling or disposal center.
-

TROUBLESHOOTING

PROBLEM	POSSIBLE CAUSE	SOLUTION
Mower fails to start.	Key not installed.	Check the key installation.
	Battery not attached or not attached securely.	Check connection of battery to mower.
	No power or power is too low.	Charge the battery.
	Defective switch.	Replace the switch (call the toll free helpline, at 866-384-8432).
	Jammed blade.	Stop mower and remove battery; check for grass and debris under the deck, clean to make blade free to move.
	Battery depleted.	Replace the battery (call the toll free helpline, at 866-384-8432).
Mower cuts unevenly.	Rough or uneven lawn.	Check the mowing area.
	Cutting height not set properly.	Set the mower at a higher position
	Dull blade.	Sharpen or replace the blade.
Mower does not mulch properly	Wet grass clippings sticking to the underside of the deck.	Wait until the grass dries before mowing.
	Missing mulching plug.	Install the mulching plug.
Mower is hard to push	High grass and low cutting height. Rear of mower housing and blade dragging in heavy grass.	Raise the cutting height.
Mower vibrates overly and makes excessive noise.	Cutting blade not assembled securely.	Tighten the blade bolts.
	Unbalanced blade.	Sharpen and balance the blade following the manual (see page 26). Or replace the blade.
	Bent motor shaft.	Stop mower and remove battery. Have the mower inspected and repaired by an authorized service center before restarting.

LawnMaster® 60V WARRANTY



LawnMaster®

LawnMaster® 60V LIMITED WARRANTY

We take pride in producing a high quality, durable product. This LawnMaster® product carries a limited four (4) year warranty against defects in workmanship and materials from date of purchase under normal household use. This warranty is void if this product is ever used while providing commercial services or if rented to another person. **Batteries and chargers carry a two-year warranty against defects in workmanship and materials from date of purchase.** Batteries must be charged in accordance with the operator's manual directions and regulations in order to be valid. Warranty does not apply to defects due to alterations, direct or indirect abuse, negligence, misuse, accidents, repairs and lack of maintenance. Please keep your receipt/packing list as proof of purchase. This warranty gives you specific legal rights, and you may have other rights, which vary from state to state. For product service call Customer Service at 866-384-8432.

Items not covered by warranty :

1. Any part that has become inoperative due to alteration, misuse, commercial use, abuse, neglect, accident, or improper maintenance.
2. The unit, if it has not been operated and/or maintained in accordance with the owner's manual.
3. Normal wear, except as noted below.
4. Routine maintenance items such as lubricants, blade sharpening, etc.
5. Normal deterioration of the exterior finish due to use or exposure.
6. Parts that can wear out from normal use within the warranty period, such as the blades, collection bags, spools, spool covers, etc.

Transportation Charges : Transportation charges for the movement of any power equipment unit or attachment are the responsibility of the purchaser. It is the purchaser's responsibility to pay transportation charges for any part submitted for replacement under this warranty unless such return is requested in writing by LawnMaster.

**THIS WARRANTY ONLY APPLIES TO ORIGINAL PURCHASER WITH PROOF OF PURCHASE.
THIS WARRANTY IS VOID WITHOUT PROOF OF PURCHASE.**

EXPLODED VIEW / PARTS LIST

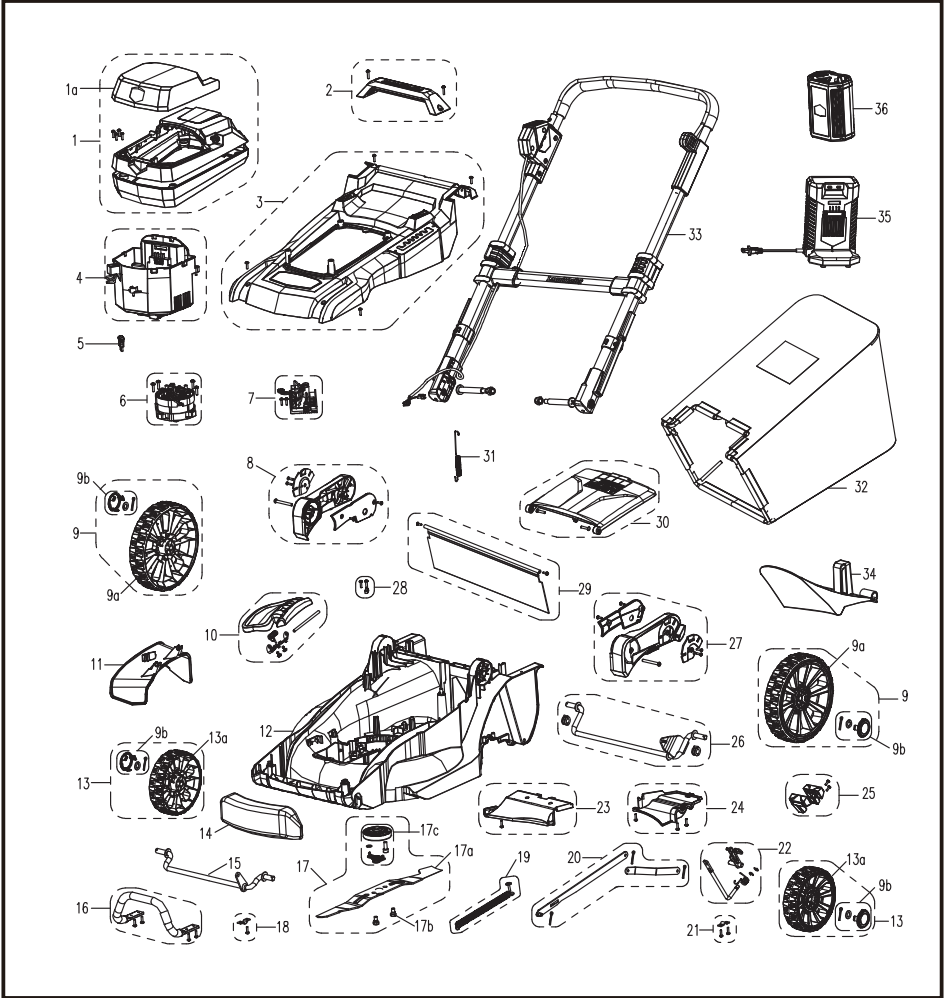

EXPLODED VIEW / PARTS LIST

CLMFT6018A MANUAL PARTS LIST			
Key Number	Part Number	Description	Quantity
1	111198101	Upper Motor Cover Assembly	1
1a	111198139	Battery Cover Housing	1
2	111198102	Motor Cover Handle Assembly	1
3	111198103	Motor Cover Assembly	1
4	111198104	Battery Holder Assembly	1
5	111198105	Safety Key	1
6	111198106	Motor Assembly	1
7	111198107	Circuit Board Assembly	1
8	111198108	Handle Bracket (Right)	1
9	111198109	Wheel Assembly (235mm)	2
9a	111198133	Wheel(235mm)	2
9b	111198134	Wheel Assembly Hardware Pack	4
10	111198110	Side Discharge Door	1
11	111198111	Side Discharge Chute	1
12	111198112	Deck Assembly	1
13	111198113	Wheel assembly (170mm)	2
13a	111198135	Wheel(170mm)	2
14	111198114	Ballast Assembly	1
15	111198116	Front Axle Assembly	1
16	111198115	Handle Assembly	1
17	111198117	Blade Assembly	1
17a	RMB6018A	Blade	1
17b	111198137	Blade Stud	2
17c	111198138	Blade Bracket Assembly	1
18	111088115	Front Axle Bracket	1
19	111005119	Height Spring Assembly	1
20	111198118	Height Connection Assembly	1
21	111198119	Height Adjustment Axle Bracket	1
22	111198120	Adjustment Assembly	1
23	111198121	Protector Plate	1
24	111198122	Deck Cover Plate	1
25	111198123	Height Adjustment Handle	1
26	111198124	Rear Axle Assembly	1
27	111198125	Handle Bracket (Left)	1
28	111008129	Cable Clamp Assembly	1
29	111198126	Rear Debris Shield	1
30	111198127	Safety Door Assembly	1
31	111193126	Safety Door Spring	1
32	111198128	Collection Bag Assembly	1
33	111198129	Handle Assembly	1
34	111198130	Mulch Plug	1
35	60LFC02-ETL	Charger	1
36	60LB5025-S	Battery	1

* Parts highlighted in gray are available for after sales purchase.

