

John Deere S160-CARB Lawn Tractor

Parts and Maintenance Information

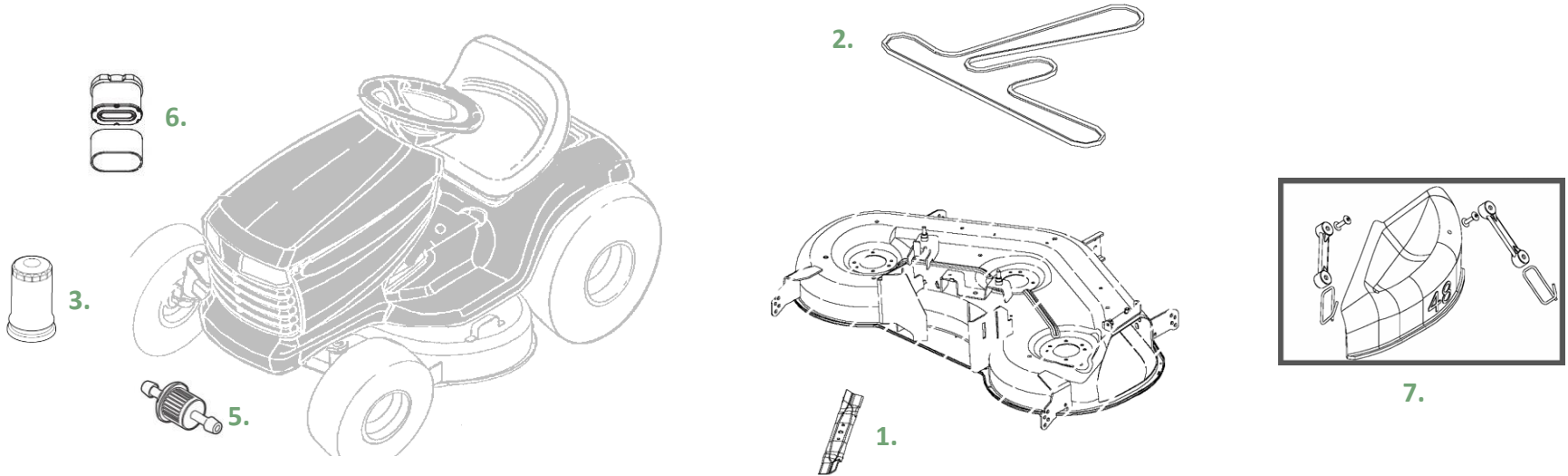

Key	Description	Part Number	THD Store SKU	THD Online SKU
1.	48 inch Mower Blade (3n1)	GY20852	469-450	100571304
2.	48 inch Mower Deck Belt	GX21833	470-341	100546396
3.	John Deere Easy Change™	AUC12916	1002832224	303336752
4.	Oil – As Needed	TY22029	226-971	100127512
5.	Fuel Filter	GY20709	289-625	100126418
6.	Air Filter	GY21057	718-508	202274986
7.	Mulch Cover	GY20417	NA	100670937

John Deere E160-CARB Lawn Tractor

Parts and Maintenance Information

- **Service Intervals**

After 8 Hours	Yearly or Every 50 Hours (Whichever Comes First)
Lubricate mower spindles and pivot points.	Change engine oil & replace filter. (Service more frequently under dusty conditions.)
Check mower deck spindle brakes (Manual PTO)	Clean/replace air filter precleaner & element. (Service more frequently under dusty conditions.)
Lubricate front axle pivot and axle spindles.	Replace fuel filter.
Lubricate front axle wheel bushings.	Sharpen/replace mower blades.
Every 25 Hours	Check/replace mower drive belt.
Lubricate mower spindles and pivot points.	Every 200 Hours
Lubricate front axle pivot and axle spindles.	Check/adjust valve clearance. See your John Deere dealer for this service.
Lubricate front axle wheel bushings.	

For complete parts information for 100 Series Tractors: Visit your local John Deere Dealer or www.Deere.com

*Refer to Operators Manual for a complete listing of service intervals.