

WOOD FENCING

Planning and Installing Your Fence

Items you may need

Tools	Materials
Power saw	String
Hammer	Grade stakes
Level	Concrete and gravel
Posthole digger	Fence panels or pickets
Power drill	Fence posts
Tape measure	2x4s for bracing posts
Carpenter's pencil	Nails or screws*

* Use hot-dip galvanized fasteners or other fasteners as required by building codes.

Preparation

Check with local ordinances and regulations before building fences in your area. Before construction, contact your local utility companies to mark any underground cables and pipelines. In addition, it's a good idea to discuss plans with any neighbors along your proposed fence line.

Design and layout

- Determine the number of posts, panels and gates needed to complete the job, based on total linear footage. Take into consideration post, panel and gate width when determining the total number of each.
- Adjust layout to accommodate as many full panels as possible. If you must use part of a panel, place in farthest rear corner of the property. Some types of pre-assembled panels can be trimmed to fit odd-sized layouts, but other types are difficult or impossible to cut to size.
- Locate property boundaries and drive stakes into the ground at corners and ends of fence line, 6" inside property boundary.
- Stretch twine or heavy string between stakes and pull tight to mark layout of fence line.
- Be sure to measure your fence panels and gates prior to locating the postholes. Also take into consideration your chosen method of attaching the backer rails to posts (see **Connecting backer rails to posts** section). Locate post placement in the following order along string line:
 - a) End/corner posts
 - b) Gate posts
 - c) Line posts

Installing fences on sloped landscapes

Fences are installed on slopes using one of two methods (Fig. 1). Preassembled panels can only be installed using the step method. The fence gradually steps up the slope with the rails level, rather than parallel to the slope.

Fig. 1

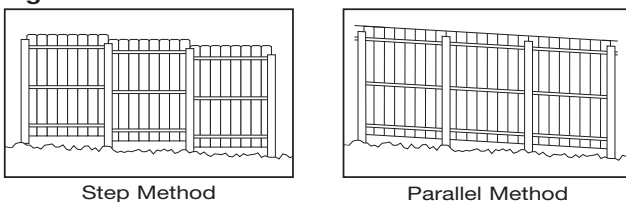

With loose components, you have the option to use the parallel method. The rails are installed based on the degree of the slope. Because this method requires that the fence be constructed to conform to the slope, it cannot be accomplished using pre-assembled fence panels.

Digging postholes

A general rule of thumb is to place 1/3 of the length of the post in the ground. Local municipalities may require postholes to be a specific depth. Please verify code compliance prior to installation. The fence will be stronger if end, corner and gate posts are set at least 6" deeper. Using a posthole digger or power auger, dig the holes 10" to 12" wide and 6" deeper than needed. Backfill the hole with 6" of gravel to drain water away from the bottom of the post (Fig. 2). Keep the height of your fence panels in mind when digging your postholes.

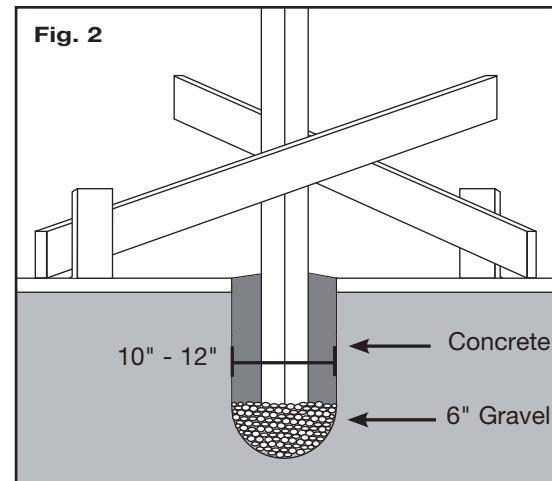

Setting posts

Install end and corner posts first. Tie a string between the posts along the fence line. This establishes a reference, ensuring the posts are in line (Fig. 3). Brace the posts using 2x4s nailed to both the posts and stakes in the ground. This will keep them straight while the concrete sets. Check for plumb (90° angle) on two adjacent sides prior to pouring concrete. Fill holes with ready-mix concrete following the package instructions. Tamp the concrete to remove any air pockets. Overfill the holes at the top and slope the concrete away from the post to keep water from collecting around it. Recheck plumb and alignment of all posts and allow concrete to cure for 24 to 48 hours.

Cutting the posts to the proper height

An easy method to ensure your post tops are level is to run a string from corner post to corner post at the desired height, keeping the string taut (Fig. 3). Mark each post at the string line and cut off the tops of the posts. Finish off your posts with one of our decorative finial tops.

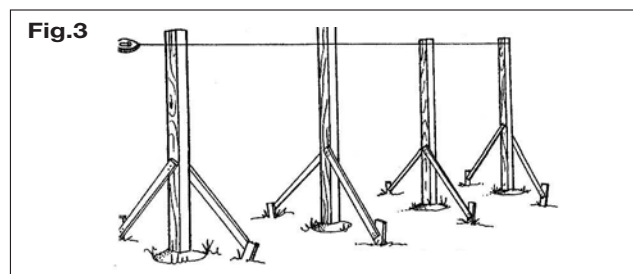

Planning and Installing Your Fence, continued

Installing panels and pickets

When installing panels or pickets, be sure to leave a minimum 2" gap between the ground and the picket bottoms. Pickets should not touch the ground.

For pre-assembled fence panels, use 18d to 20d nails to attach them to the posts. If possible, pre-drill holes through the panels to minimize any splitting from using such a large nail.

To install loose pickets to backer rails, use 8d or 10d box nails. Start at one end of the rail and check for level and plumb every three or four pickets. If you wish to build a solid "privacy" fence, butt the pickets without leaving a gap in between. To build a spaced picket fence, cut a board the width of the desired gap and use it as a spacer. Remember to check for plumb every few pickets. Use three backer rails for fences 6' tall and higher and two rails for shorter fences. Note: Attach rails 4" from the top and bottom of pickets to minimize picket movement.

Connecting backer rails to posts

There are many ways to attach backer rails or stringers to the posts (Fig. 4).

Place a board under pre-assembled panels to use as a lever to adjust the panel to the proper height on the post. All backer rails should run the same measurement to the ground and to each other on a horizontal plane, regardless of minor grade changes. Your finished product will be much more appealing to the eye if proper attention is given to this detail.

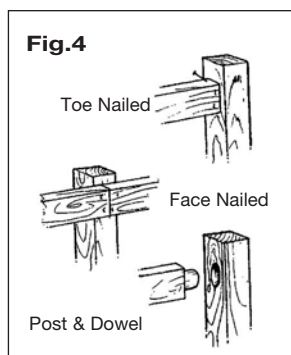

Gate installation

- Determine the swing direction (left- or right-hand open).
- Mount hinge hardware to gate frame at the proper height, pre-drilling all screw holes.
- Mount gate to gate post, pre-drilling all screw holes.
- Check for full gate swing clearance.
- Mount latch hardware, pre-drilling all screw holes.

Finishing your fence/initial maintenance

Applying a protective finish is recommended to prolong the life of your fence. The type of finish will be determined by the look desired and the wood species used. There are three options in finishing treatments: stain, paint and waterproofing sealer. Clean your fence with a cleaner/brightener that contains a mildewcide, prior to applying your finish.

- Stain provides a durable finish coat while maintaining the natural look of wood. A semitransparent stain is recommended for new fences. It gives an even appearance and hint of color while allowing the grain to show through.
- Paint adds color as it protects and seals the fence. The color can easily be coordinated with your home. Clean, dry and prime with oil-based primer prior to painting the fence. A durable exterior latex paint is recommended.
- Waterproofing sealer is best for woods that are not naturally resistant to decay or are exposed to weather. The sealer helps prevent rain and moisture from soaking into the wood. Choose one with a UV stabilizer to slow the discoloration process.

Common maintenance concerns

The continuous changes in weather conditions are extremely harsh on your fence. Your maintenance plan must be geared to combat the problems caused by water absorption and water loss, mildew growth, and discoloration of wood due to the sun's ultraviolet rays. All of the maintenance concerns discussed below are weather-related. The degree to which your fence is affected by them depends on many factors. These factors include general climate conditions (such as normal precipitation, humidity, etc.) and location in your yard (with regard to direct sun exposure, foliage coverage, etc.). If your fence is built using pressure-treated lumber, it is important to note that the pressure treatment does not increase the likelihood that your fence will develop these natural defects to any greater degree than the same material left untreated. These weather-related defects are beyond the control of the pressure treatment process.

Natural characteristics of wood

We cannot control the occurrence of the natural characteristics of the wood, which may include raised grain, splitting, warping, shrinking, swelling or twisting. Continuous water absorption and water loss in the wood used for your fence will cause its natural defects to surface. A well-maintained fence will still experience some of these natural defects. However, the extent can be significantly reduced through a maintenance plan.

To effectively combat these maintenance concerns, it will be up to you to follow a preventative maintenance plan.

Your initial maintenance plan should be determined by water absorption and loss, mildew growth and UV discoloration.

- First-year maintenance: Reapply cleaner/brightener as described in initial maintenance, and as called for by the finish of your choice (paint, stain or waterproofing sealer).
- Future periodic preventative maintenance: Depending on the location of your fence with regard to direct sun exposure, foliage, coverage, etc., it may be sufficient to clean/brighten and recoat every two years. A power washer may be necessary to properly clean your fence.