

C Series Freezer

Le Congélateur de Feuilleton de c

Congelador de Serie C

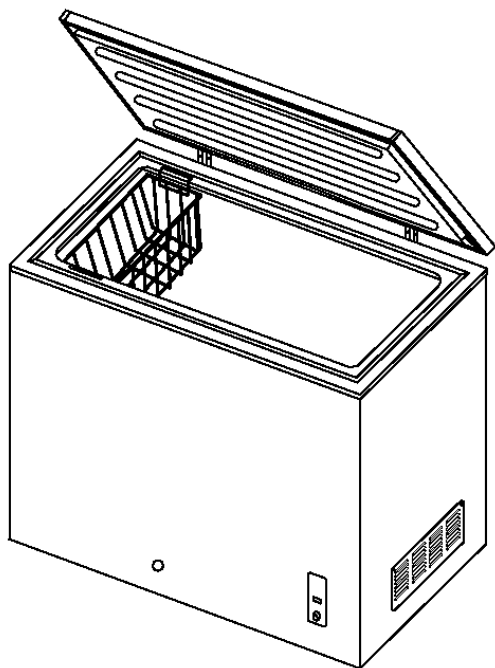

User Manual
HCM050EC, HCM050LC, HCM070LC

Guide de l'Utilisateur
HCM050EC, HCM050LC, HCM070LC

Manual del Usuario Modelo
HCM050EC, HCM050LC, HCM070LC

Haier

Quality · Innovation · Style

SAFETY PRECAUTIONS

Read all of the instructions before using this appliance. When using this appliance, always exercise basic safety precautions, including the following:

1. Use this appliance only for its intended purpose as described in this use and care guide.
2. This freezer must be properly installed in accordance with the installation instructions before it is used. See grounding instructions in the installation section.
3. Never unplug your freezer by pulling on the power cord. Always grasp the plug firmly and pull straight out from the outlet.
4. Repair or replace immediately, all electric service cords that have become frayed or otherwise damaged. Do not use a cord that shows cracks or abrasion damage along its length, the plug or the connector end.
5. Unplug your freezer before cleaning or before making any repairs.
Note: If for any reason this product requires service, we strongly recommend that a certified technician performs the service.
6. Do not use any electrical device or any sharp instrument in defrosting your freezer.
7. If your old freezer is not being used, we recommend that you remove the doors. This will reduce the possibility of danger to children.
8. After your freezer is in operation, do not touch the cold surfaces in the freezer compartment, particularly when hands are damp or wet. Skin may adhere to these extremely cold surfaces.
9. Do not refreeze foods, which have been thawed completely. The United States Department of Agriculture in Home and Garden Bulletin No. 69 reads: "...You may safely refreeze frozen foods that have thawed if they still contain ice crystals or if they are still cold-below 40°F".

"...Thawed ground meats, poultry, or fish that have any off-odor or off-color should not be refrozen and should not be eaten. Thawed ice cream should be discarded. If the odor or color of any food is poor or questionable, discard it. The food may be dangerous to eat."

"...Even partial thawing and re-freezing reduce the eating quality of foods, particularly fruits, vegetables, and prepared foods. The eating quality of red meats is affected less than that of many other foods. Use refrozen foods as soon as possible, to save as much of its eating quality as you can."

10. This freezer should not be recessed or built-in an enclosed cabinet. It is designed for freestanding installation only.
11. Do not operate your freezer in the presence of explosive fumes.

SAVE THESE INSTRUCTIONS

For Future Reference Please

DANGER

Risk of child entrapment. Before you throw away your old refrigerator or freezer, take off the doors. Leave the shelves in place so that children may not easily climb inside.

Thank you for using our Haier product. This easy-to-use manual will guide you in getting the best use of your freezer.

Remember to record the model and serial number. They are on a label in back of the freezer.

Model number

Serial number

Date of purchase

Staple your receipt to your manual.

You will need it to obtain warranty service.

Table Of Contents

	PAGE
Safety Precautions	1
Parts And Features	4
Installing Your Freezer	5
Unpacking Your Freezer	5
Adjusting Your Freezer	5
Proper Air Circulation	5
Electrical Requirements	6
Use of Extension Cords	6
Install Limitations.....	6
Freezer Features And Use	7
Operating Your Freezer	7
General Features	7
Food Storage Baskets	8
Defrosting And Draining	8
Food Storage Information	9
Normal Operating Sounds	9
Proper Freezer Care and Cleaning	10
Cleaning and Maintenance	10
Power Interruptions	11
Vacation and Moving Care	11
Troubleshooting	12
Warranty Information	14

Parts and Features

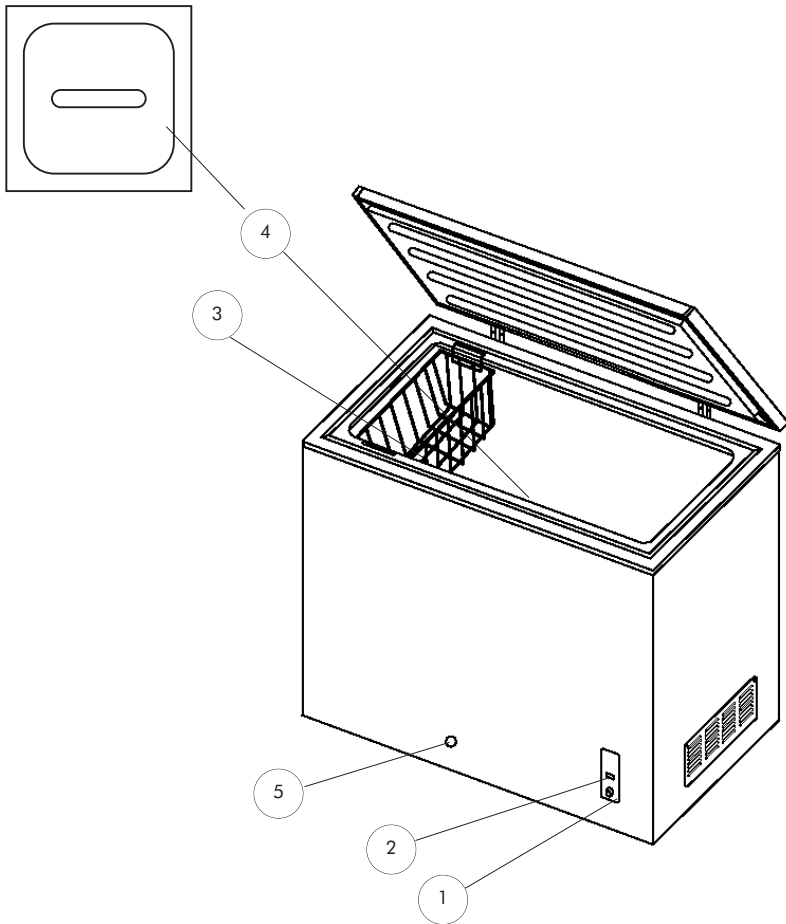

1. Temperature Control Adjustment
2. Power-On Indicator (Green) (Not in all models)
3. Vinyl Coated Wire Basket (Not in all models)
4. Interior Drain Plug (See Insert)
5. Exterior Drain Plug

Installing Your Freezer

Unpacking Your Freezer

1. Remove all packaging material. This includes the foam base and all adhesive tape holding the freezer accessories inside and outside.
2. Inspect and remove any remains of packing, tape or printed materials before powering on the freezer.

Adjusting Your Freezer

- Your freezer is designed for freestanding installation only. It should not be recessed or built-in.
- Place the freezer on a floor strong enough to support it fully loaded.
- When moving the freezer, never tilt it more than a 45-degree angle. This could damage the compressor and the sealed system.
- If the freezer is tilted let it stand in an upright position for at least 24 hours prior to plugging. This is to allow the refrigerant to settle.

Proper Air Circulation

- To assure your freezer works at the maximum efficiency it was designed for, you should install it in a location where there is proper air circulation, plumbing and electrical connections.
- The following are recommended clearances around the freezer:
Sides.....4" (102mm)
Top.....4" (102mm)
Back.....4" (102mm)

Electrical Requirement

- Make sure there is a suitable power Outlet (115 volts, 15 amps outlet) with proper grounding to power the freezer.
- Avoid the use of three plug adapters or cutting off the third grounding in order to accommodate a two plug outlet. This is a dangerous practice since it provides no effective grounding for the freezer and may result in shock hazard.

Use of Extension Cord

- Avoid the use of an extension cord because of potential safety hazards under certain conditions. If it is necessary to use an extension cord, use only a 3-wire extension cord that has a 3-blade grounding plug and a 3-slot outlet that will accept the plug. The marked rating of the extension cord must be equal to or greater than the electrical rating of the appliance.

Install Limitations

- Do not install your freezer in any location not properly insulated or heated e.g. garage etc. Your freezer was not designed to operate in temperature settings below 55° Fahrenheit or above 90° Fahrenheit.
- Select a suitable location for the freezer on a hard even surface away from direct sunlight or heat source e.g. radiators, baseboard heaters, cooking appliances etc. Any floor unevenness should be corrected.

Freezer Features and Use

Operating Your Freezer

- Once the freezer is in its proper place, plug it in an electrical outlet having 115 volts and 15 amps. Turn on power switch. Power light will come on, the green run light will be lit indicating that the freezer has power.
- Set the temperature, on the temperature control knob. "1" being the warmest and "7" being the coldest. Initially set the temperature on "4". Place food inside the freezer. After using the freezer for 24 hours set the freezer to your desired setting.
- In case you unplug your freezer or experience an electrical outage, allow 5 minutes before plugging it back in.

General Features

Adjustable temperature dial: (see fig. # 1)

Your freezer will automatically maintain the temperature level you select. The temperature control dial has 7 settings plus OFF. "1" is the warmest, "7" is the coldest. Turning the dial to OFF stops cooling the freezer. Set the dial to "4" and allow 24 hours to pass before adjusting the temperature to your needs.

(Note: If the freezer has been placed in a horizontal or tilted position for any period of time wait 24 hours before plugging the unit in.)

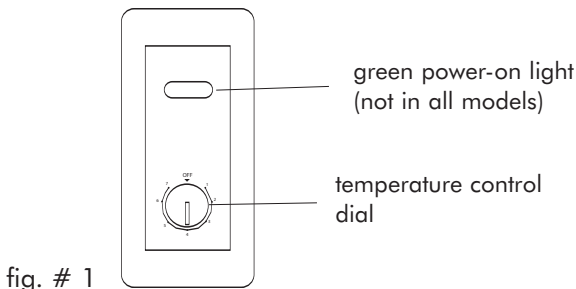

Food Storage Basket (Not in all models)

(see fig. # 2)

- Depending on your model purchased your freezer may have a food storage basket. Removable baskets allow you to store food more accessibly or you can remove them if not needed.



fig. # 2

Defrosting and Draining

- Defrost whenever the frost becomes 1/4" thick. Never use a sharp or metallic instrument to remove the frost, as it may damage the cooling coils. (A punctured coil will void the warranty)
- Turn the temperature control to OFF position and unplug the unit. Remove the drain plug from the inside of the freezer. Defrosting usually takes a few hours. To defrost faster keep the freezer door open.
- For draining, place a tray beneath the outer drain plug. Pull out the drain dial (see fig. #3). This will let the water flow out in the tray. When done, push the drain dial in. Re-plug the drain plug inside the freezer compartment. **Note:** monitor the container under the drain to avoid overflow.
- Wipe the interior of the freezer and replace the electrical plug in the electrical outlet.
- Reset the temperature control to the desired setting.

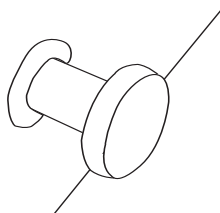

fig. # 3

Food Storage Information

Frozen Food:

- Wipe containers before storing to avoid needless spills.
- Hot food should be allowed to cool before storing in the freezer. This will prevent unnecessary energy use.
- When storing meats, keep in the original packaging or rewrap as necessary.
- Proper freezer storage requires correct packaging. All foods must be in packages, which do not allow the flow of air or moisture in, or out. Improper storage will result in odor and taste transfer and will result in the drying out of the improperly packaged food.
- Follow package or container instructions for proper storage.
- **Packaging Recommendations:**
 - Plastic containers with air tight lids
 - Heavy duty aluminum foil
 - Plastic wrap made from saran film
 - Self-sealing plastic bags
- Do not refreeze defrosted/thawed foods.
- It is recommended that the freezing date be marked on the packaging.

Normal Operating Sounds You May Hear

- Boiling water, gurgling sounds or slight vibrations that are the result of the refrigerant circulating through the cooling coils.
- The thermostat control will click when it cycles on and off.

Proper Freezer Care and Cleaning

Cleaning and Maintenance

Warning: To avoid electric shock always unplug your freezer before cleaning. Ignoring this warning may result in death or injury.

Caution: Before using cleaning products, always read and follow manufacturer's instructions and warnings to avoid personal injury or product damage.

General:

- Prepare a cleaning solution of 3-4 tablespoons of baking soda mixed with warm water. Use sponge or soft cloth, dampened with the cleaning solution, to wipe down your freezer.
- Rinse with clean warm water and dry with a soft cloth.
- Do not use harsh chemicals, abrasives, ammonia, chlorine bleach, concentrated detergents, solvents or metal scouring pads. SOME of these chemicals may dissolve, damage and/or discolor your freezer.

Door Gaskets: • Clean door gaskets every three months according to general instructions. Gaskets must be kept clean and pliable to assure a proper seal.

- Petroleum jelly applied lightly on the hinge side of gaskets will keep the gasket pliable and assure a good seal.

Power Interruptions

- Occasionally there may be power interruptions due to thunderstorms or other causes. Remove the power cord from AC outlet when a power outage occurs. When power has been restored, replug power cord to AC outlet. If outage is for a prolonged period, inspect and discard spoiled or thawed food in freezer. Clean freezer before reusing.

Vacation and Moving Care

- For long vacations or absences, empty food from freezer, move the temperature DIAL to the OFF position and clean the door gaskets according to "General cleaning" section. Prop doors open, so air can circulate inside. When moving always move the freezer vertically. Do not move with the unit lying down. Possible damage to the sealed system could occur.

Troubleshooting

Freezer Does Not Operate:

- Check if thermostat control is not in the "OFF" position.
- Check if freezer is plugged in.
- Check if there is power at the ac outlet, by checking the circuit breaker.
- Wait for 30-40 minutes to see whether freezer will start. Compressor cycle must be complete to operate.

Food temperature appears too warm:

- Frequent door openings.
- Allow time for recently added warm food to reach freezer temperature.
- Check gaskets for proper seal.
- Clean condenser coils (for models with exposed condenser coils).
- Adjust temperature control to colder setting.

Food temperature is too cold:

- If temperature control setting is too cold, adjust to a warmer setting and allow several hours for temperature to adjust.

Freezer runs too frequently:

- This may be normal to maintain constant temperature during high temperature and humid days.
- Doors may have been opened frequently or for an extended period of time.
- Check gasket for proper seal.
- Check to see if doors are completely closed.
- Check freezer compartment for blockage from frozen food packages, containers, etc.

Freezer has an odor:

- Interior needs cleaning.
- Foods improperly wrapped or sealed are giving off odors.

Limited Warranty

What is covered and for how long?

This warranty covers all defects in workmanship or materials for a period of:

12 months for labor

12 months for parts (Functional Parts Only)

5 years for sealed system

The warranty commences on the date of item purchase. Customer shall provide Haier with proof of the date of purchase, brand, model and serial number for verification prior to any warranty service being provided.

EXCEPTIONS: Commercial or Rental Use warranty

90 days for labor

90 days for parts

No other warranty applies

What is covered/Not covered?

1. The mechanical and electrical parts of the appliance which serve the functional purpose of this appliance are covered for a period of 12 months. This includes all parts except finish and trim.
2. Manufacturing defects to the components of the sealed system (e.g. hermetic compressor, condenser and evaporator) are covered for a period of 5 years from the date of purchase. Any damages to such components caused by mechanical abuse, improper handling or shipping will not be covered.
3. The limited warranty does not cover any credit or refund for any loss or injury caused by the product or defects to the product including but not limited to incidental or consequential damages.

What will be done?

1. Any mechanical or electrical part that proves to be defective in normal usage during the specified warranty period will be repaired or replaced at Haier's discretion.

A&E factory service is the authorized service provider for Haier.

If it is determined that repair is not appropriate or replacement part is unavailable for repair, Haier will exchange the product with a refurbished or new product the same or similar to the original at its discretion.

2. There will be no charge to the purchaser for functional replacement parts and labor on any

covered items during the initial 12-month period. Beyond this period, only the components of the sealed system are covered, labor is not provided and must be paid for by the customer.

3. To have your product serviced, please contact Haier customer service
1-877-337-3639.

THIS WARRANTY COVERS APPLIANCES WITHIN THE CONTINENTAL UNITED STATES, PUERTO RICO AND CANADA. IT DOES NOT COVER THE FOLLOWING:

- Damages from improper installation.
- Damages incurred during shipping.
- Defects other than manufacturing.
- Damage from misuse, abuse, accident, alteration, lack of proper care and maintenance or incorrect current overvoltage.
- Damage from other than household use.
- Damage from service by other than an authorized dealer or service center.
- Decorative trims or replaceable light bulbs.
- Transportation and shipping.
- Labor (after the initial 12 months).
- Credit or Refund for products over 30 days past date of purchase
- Food loss for food spoiled as a direct result of mechanical failure of the product or of any delay in providing service, repair, replacement.
- This limited warranty doesn't apply to refurbished product or unit purchased as/like new or second-hand.

THIS LIMITED WARRANTY IS GIVEN IN LIEU OF ALL OTHER WARRANTIES, EXPRESSED OR INCLUDING THE WARRANTIES OF MERCHANTABILITY AND FITNESS FOR A PARTICULAR PURPOSE

The remedy provided in this warranty is exclusive and is granted in lieu of all other remedies. This warranty does not cover incidental or consequential damages, so the above limitations may not apply to you. Some states do not allow limitations on how long an implied warranty lasts, so the above limitations may not apply to you. This warranty gives you specific legal rights, and you may have other rights, which vary from state to state.

Haier America
New York, NY 10018.
877-337-3639

IMPORTANT

Do Not Return This Product To The Store

If you have a problem with this product, please contact the "Haier Customer Satisfaction Center" at 1-877-337-3639.

DATED PROOF OF PURCHASE REQUIRED FOR WARRANTY SERVICE

IMPORTANT

Ne pas Réexpédier ce Produit au Magasin

Pour tout problème concernant ce produit, veuillez contacter le service des consommateurs 'Haier Customer Satisfaction Center' au 1-877-337-3639.
UNE PREUVE D'ACHAT DATEE EST REQUISE POUR BENEFICIER DE LA GARANTIE.

IMPORTANTE

No regrese este producto a la tienda

Si tiene algún problema con este producto, por favor contacte el "Centro de Servicio al Consumidor de Haier" al 1-877-337-3639 (Válido solo en E.U.A).

NECESITA UNA PRUEBA DE COMPRA FECHADA PARA EL SERVICIO DE LA GARANTIA

115V, 60 Hz

Made in China
Fabriqué en Chine
Hecho en China

Haier

**Haier America
New York, NY 10018**

Printed in China