



Item #661532

Model #S5-ADH04301

USE AND CARE GUIDE

NILES PARK SWIVEL ROCKER

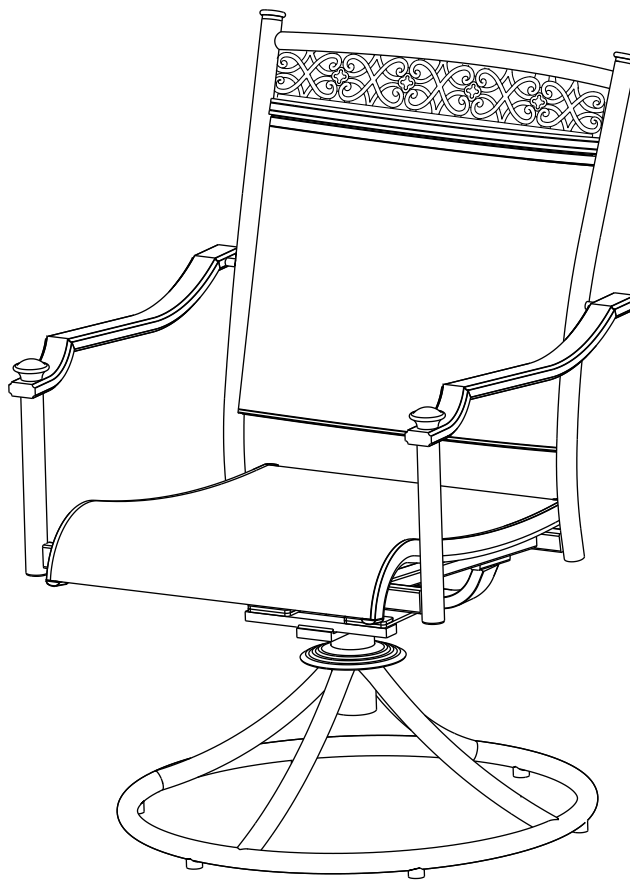

Questions, problems, missing parts? Before returning to the store,
call Hampton Bay Customer Service
8 a.m. - 6 p.m., EST, Monday - Friday

1-855-HD-HAMPTON

HAMPTONBAY.COM

THANK YOU

We appreciate the trust and confidence you have placed in Hampton Bay through the purchase of this rocker.

We strive to continually create quality products designed to enhance your home.

Visit us online to see our full line of products available for your home improvement needs.

Thank you for choosing Hampton Bay!

Table of Contents

Table of Contents.....	2	Assembly.....	5
Warranty	2	Maintenance	6
What is Covered	2	Care and Cleaning	6
What is Not Covered	2	Troubleshooting	6
Pre-Assembly	3		
Planning Assembly.....	3		
Hardware Included.....	3		
Package Contents.....	4		

Warranty

3 Year Frame Limited Warranty / 2 Year Fabric Limited Warranty

What is Covered

We warrant the frame to be free of manufacturing defects to the original purchaser for three years and the fabric for two years.

What is Not Covered

It remains the customer's responsibility for freight and packaging charges to and from our service center. This warranty does not cover commercial use, hardware, acts of nature, fire, freezing and abusive use. In addition, purchased parts are not covered under this warranty. We reserve the right to make substitutions with similar merchandise, if the model in question is no longer in production.

Contact Customer Care at 1-855-HD-HAMPTON or visit www.HamptonBay.com.

Pre-Assembly

PLANNING ASSEMBLY

Identify all parts packed in the carton against the parts list. Remove all protective materials. Place parts on a non-abrasive surface to avoid scratching. If you are missing any parts or are unsure how to proceed with the assembly, call our Customer Service Team at 1-855-HD-HAMPTON. Do not attempt assembly if any parts are missing or damaged.

Two people may be required to assemble the rocker.

Damage to welds or frames resulting from over tightened bolts or improper assembly is not covered under our warranty. Please read all instructions carefully before assembly. If you have any questions regarding your assembly, call our Customer Service Team at 1-855-HD-HAMPTON.

HARDWARE INCLUDED



NOTE: Hardware not shown to actual size.

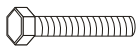

___AA



___BB



___CC



___DD



___EE



___FF



___GG

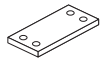

___HH



___II



___JJ

Part	Description	Order Part #	Quantity
AA	5/16 in. x 40 mm Bolt	HW0794	4
BB	Ø8.0 x 2.3 mm Spring Washer	HW0003	4
CC	Metal Plate	HW0686	4
DD	5/16 in. Nut	HW0015	4
EE	Bolt Cover	HW0028	8
FF	Hex Wrench-1	HW0008	1
GG	Hex Wrench-2	HW0007	1
HH	Rocker Plate (Preassembled)	G0228	2
II	Foot Cap (Preassembled)	FC0013	6
JJ	Sling Tube Cap (Preassembled)	FC0427	4

Pre-Assembly (continued)

PACKAGE CONTENTS

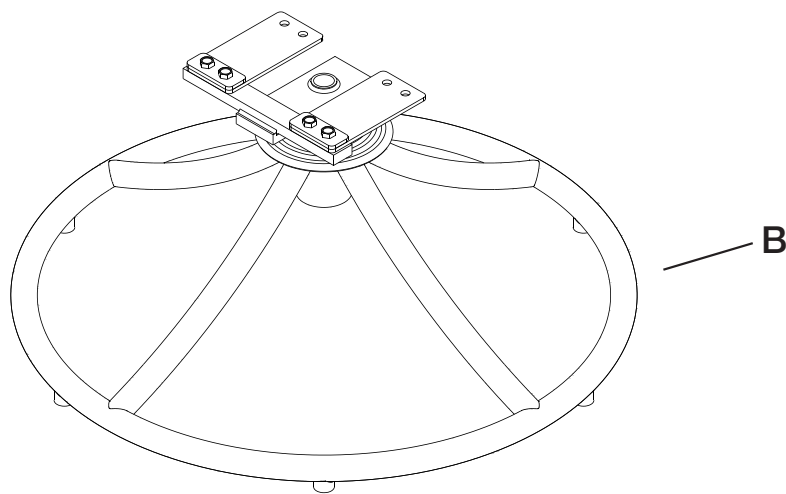
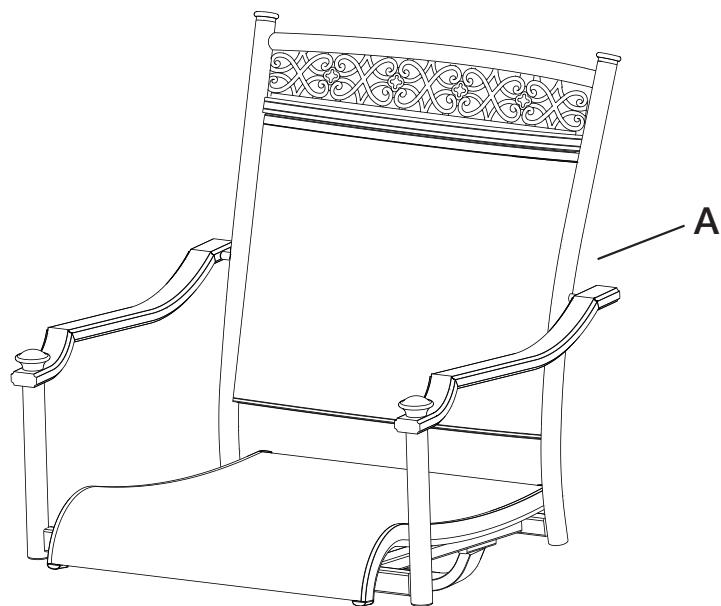

Part	Description	Order Part #	Quantity
A	Chair Frame	AR19771	1
B	Swivel Base	AR19772	1

Assembly

1 Positioning the chair frame

- Place the swivel base (B) on a flat, solid surface.
- Ensure the rocker portion (preassembled parts HH) of the swivel base (B) is positioned all the way into the swivel base (B). It may have shifted or vibrated out during shipment.
- Note the arrow labels on the "U" bar and the rocker assembly (HH). Also note the horseshoe shape of the assembled rocker plate (HH).
- Point the open end of the horseshoe away from you, so that the arrows on the rocker assembly (HH) point towards you.
- Set the chair frame (A) on the rocker assembly (HH) with the front of the seat facing you and the arrows on the "U" bar pointing towards you. If the chair frame (A) has been properly positioned on the rocker assembly (HH), all arrows on the "U" bar and rocker assembly (HH) will be pointing in the same direction.

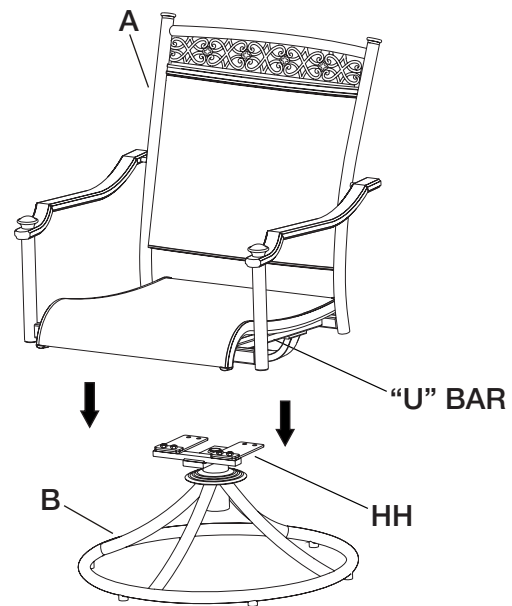

2 Attaching the chair frame to the chair base



CAUTION: Failure to place the metal plates (CC) under and above the rocker plates (HH) exactly as shown in the diagram will cause the bolt heads and nuts to damage the structure of the rocker plates. Damage due to over tightening of bolts or improper assembly could cause injury and may void your warranty.

- Place a metal plate (CC) on the topside of the "U" bar, aligning the holes in the metal plate (CC) with the holes in the "U" bar.
- Guide two bolts (AA) through the holes in the metal plate (CC), through the hole in the "U" bar, and then through the hole in the rocker plate (HH).
- Finally, add a spring washer (BB) and a nut (DD) to the bottom of each bolt (AA). Hand tighten the nuts (DD) 3-4 revolutions only.
- Repeat the same procedure on the other side of the rocker assembly (HH).
- Cover all bolts with bolt covers (EE).

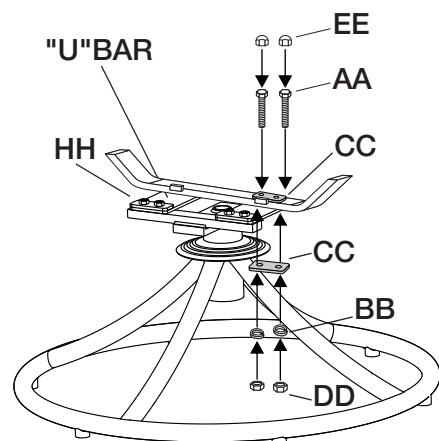

Maintenance

FRAME:

Periodically clean and dry thoroughly. Be sure to drain any water accumulated inside the frames. To thoroughly drain the frames, remove the foot caps and tilt the frames, if necessary, to remove all water. This is critical. Water allowed to accumulate inside the frames and then exposed to sub-freezing temperatures can cause damage to the frame tubing. Such damage is not covered under the warranty. Always clean, drain, and dry thoroughly before storing for the winter. For best results, always store or cover your furniture when not in use. We recommend commercially available outdoor furniture covers. Any small nicks or scratches can be covered with a light application of touchup paint.

FABRIC (CUSHIONS/SLINGS):

The best way to maintain the beauty of cushions and slings is to store them in a dry area and out of the elements when not in use or cover with commercially available outdoor furniture covers.

Care and Cleaning

FRAME:

Use mild soap and warm water. Do not use abrasive materials, cleansers, or bleach products. Rinse with clean water and dry thoroughly.

FABRIC (CUSHIONS/SLINGS):

Wipe minor spills immediately. Clean with mild soap, warm clean water, and a soft cloth. Do not use abrasive materials, cleansers, or bleach products. Although fabric has been treated to resist stains, occasional use of commercially available fabric cleaners may be necessary. Follow the manufacturer's instructions.

Troubleshooting

If your chair is not rocking properly, double-check your assembly procedure, especially Step 2. If the chair rocks too far forward or is difficult to rock backwards, you have probably installed the seat frame backwards on the rocker assembly.



Questions, problems, missing parts? Before returning to the store,
call Hampton Bay Customer Service
8 a.m. - 6 p.m., EST, Monday - Friday

1-855-HD-HAMPTON

HAMPTONBAY.COM

Retain this manual for future use.



Item #661534

Model #S5-ADH04301

USE AND CARE GUIDE

NILES PARK 48 IN. ROUND CAST TOP DINING TABLE

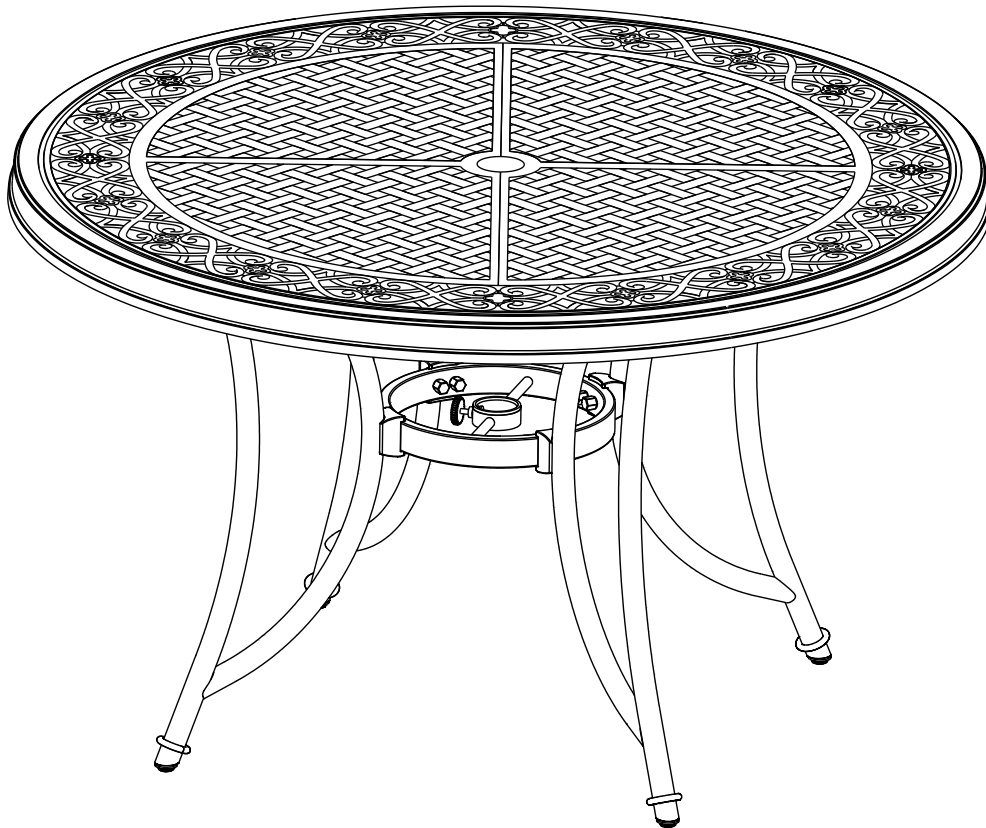

Questions, problems, missing parts? Before returning to the store,
call Hampton Bay Customer Service
8 a.m. - 6 p.m., EST, Monday - Friday

1-855-HD-HAMPTON

HAMPTONBAY.COM

THANK YOU

We appreciate the trust and confidence you have placed in Hampton Bay through the purchase of this table.

We strive to continually create quality products designed to enhance your home.

Visit us online to see our full line of products available for your home improvement needs.

Thank you for choosing Hampton Bay!

Table of Contents

Table of Contents.....	2	Assembly.....	5
Warranty	2	Maintenance	6
What is Covered	2	Care and Cleaning	6
What is Not Covered	2		
Pre-Assembly	3		
Planning Assembly.....	3		
Hardware Included.....	3		
Package Contents.....	4		

Warranty

3 Year Frame Limited Warranty

What is Covered

We warrant the frame to be free of manufacturing defects to the original purchaser for three years.

What is Not Covered

It remains the customer's responsibility for freight and packaging charges to and from our service center. This warranty does not cover commercial use, hardware, acts of nature, fire, freezing and abusive use. In addition, purchased parts are not covered under this warranty. We reserve the right to make substitutions with similar merchandise, if the model in question is no longer in production.

Contact Customer Care at 1-855-HD-HAMPTON or visit www.HamptonBay.com.

Pre-Assembly

PLANNING ASSEMBLY

Identify all parts packed in the carton against the parts list. Remove all protective materials. Place parts on a non-abrasive surface to avoid scratching. If you are missing any parts or are unsure how to proceed with the assembly, call our Customer Service Team at 1-855-HD-HAMPTON. Do not attempt assembly if any parts are missing or damaged.

Two people may be required to assemble the table.

Damage to welds or frames resulting from over tightened bolts or improper assembly is not covered under our warranty. Please read all instructions carefully before assembly. If you have any questions regarding your assembly, call our Customer Service Team at 1-855-HD-HAMPTON.

HARDWARE INCLUDED



NOTE: Hardware not shown to actual size.

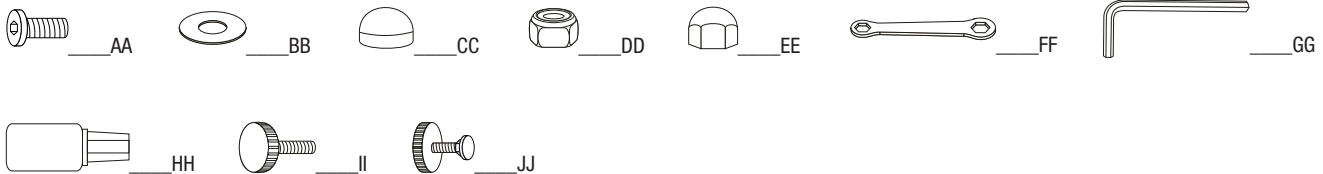

Part	Description	Order Part #	Quantity
AA	1/4 in. x 18 mm Bolt	HW0035	8
BB	Ø6.5 x 1.0 mm Washer	HW0004	16
CC	Bolt Cover	HW0105	8
DD	1/4 in. Nut	HW0014	8
EE	Nut Cover	HW0027	8
FF	Hex Wrench	HW0009	1
GG	Hex Bolt Driver	HW0006	1
HH	Touch-up Paint	G0003	1
II	Foot Cap (Preassembled)	FC0614	4
JJ	Umbrella Pole Stopper & Nut (Preassembled)	G0091 & HW0448	1

Pre-Assembly (continued)

PACKAGE CONTENTS

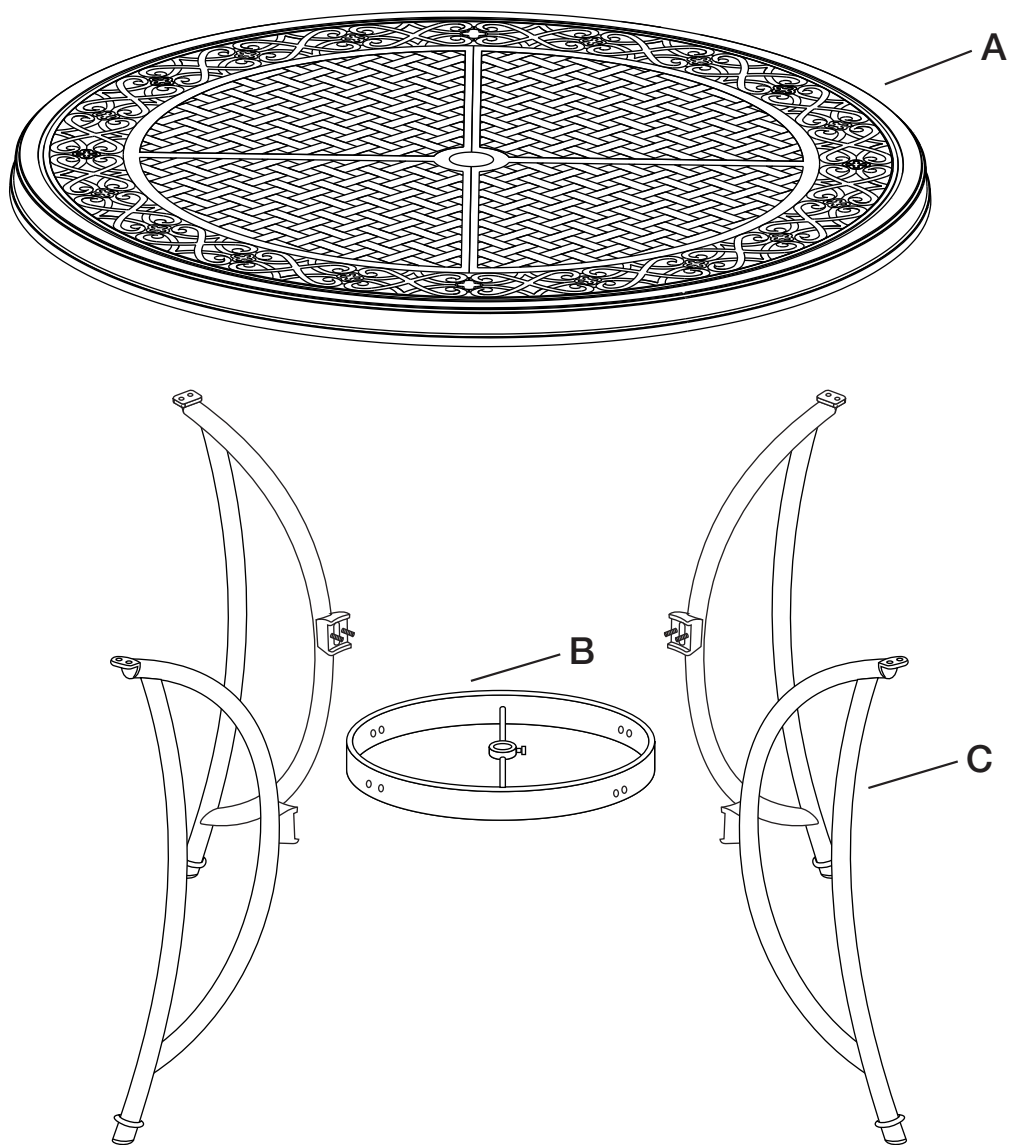

Part	Description	Order Part #	Quantity
A	Tabletop	AT71909	1
B	Leg Connector Bracket	AT71910	1
C	Table Leg	AT71911	4

Assembly

1 Assembling the table legs

- Place the tabletop (A) up-side down on a flat, solid surface.
- Attach a table leg (C) to the tabletop (A) by using the bolts (AA) and washers (BB) as shown in the diagram.
- Guide the bolts (AA) through the holes in the table leg (C), and into the pre-drilled holes in the tabletop (A).
- Hand tighten three to four turns only. (Do not tighten completely. Some adjustments may be necessary to ensure proper alignment of the table legs.)
- Repeat for the other three legs.

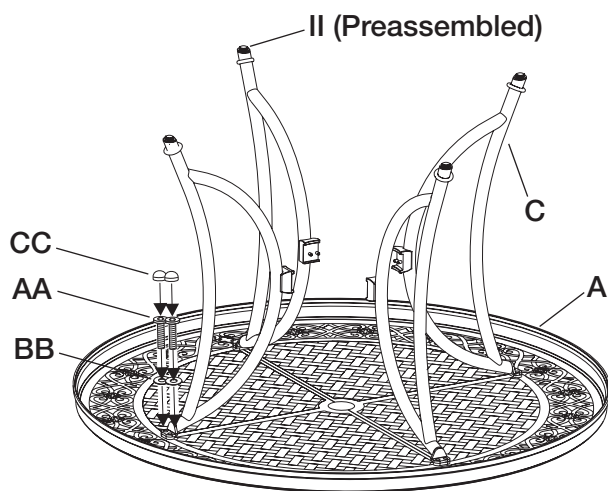

2 Assembling the leg connector bracket

- Attach a leg (C) to the leg connector bracket (B) by carefully guiding the bolts (AA) through the holes, in the leg (C) and connector bracket (B).
- Add a washer (BB) and a nut (DD) to the end of each bolt.
- Hand tighten three to four turns only. (Do not tighten completely.)
- Repeat on the other three legs.

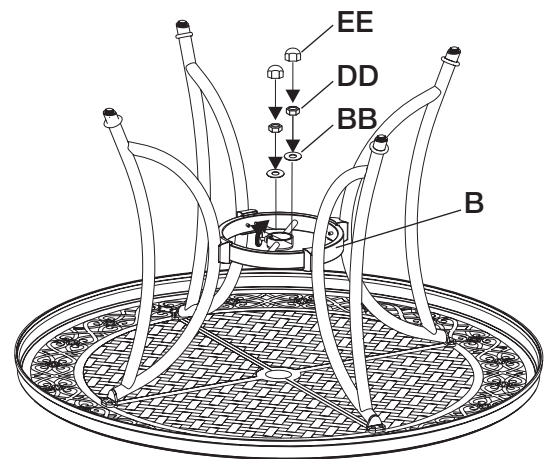

3 Tightening the nuts to the bolts

- Use the hex bolt driver (GG) and hex wrench (FF) to tighten all nuts (DD) and bolts (AA). (Do not over tighten. Over tightening may strip bolts.)
- Cover all nuts (DD) and bolts (AA) with covers (CC and EE).
- Place the table right side up. If the table appears uneven, twist the foot caps (II) on the bottom of the legs to level the table.

Maintenance

Periodically clean and dry thoroughly. Be sure to drain any water accumulated inside the frame. To thoroughly drain the frame, remove the foot caps and tilt the frame, if necessary, to remove all water. This is critical. Water allowed to accumulate inside the frame and then exposed to sub-freezing temperatures can cause damage to the frame tubing. Such damage is not covered under the warranty. Always clean, drain, and dry thoroughly before storing for the winter. For best results, always store or cover your furniture when not in use. We recommend commercially available outdoor furniture covers. Any small nicks or scratches can be covered with a light application of touch-up paint.

Care and Cleaning

Use mild soap and warm water. Do not use abrasive materials, cleansers, or bleach products. Rinse with clean water and dry thoroughly.



Questions, problems, missing parts? Before returning to the store,
call Hampton Bay Customer Service
8 a.m. - 6 p.m., EST, Monday - Friday

1-855-HD-HAMPTON

HAMPTONBAY.COM

Retain this manual for future use.