

# Millbridge Energystar 52" Ceiling Fan



## Specifications

<b>Material Construction:</b>	Steel
<b>Motor Size:</b>	153mm X 20mm
<b>Diameter:</b>	52"
<b>Downrod:</b>	4"
<b>Mounting:</b>	Tri-Mount adaptable (downrod, close-to-ceiling & vaulted ceiling)
<b>Blade Details:</b>	5 blades: MDF
<b>Blade Color:</b>	Reversible: Black/ Light Maple
<b>Blade Material:</b>	Zinc Die Casted
<b>Speed Control:</b>	3 speed pull chain control
<b>Voltage:</b>	120V
<b>Weight:</b>	18.8 lbs.
<b>Light Kit - Lens</b>	Frosted Opal Glass
<b>Light Kit - Lamp Info</b>	3 x 60W, candelabra-based incandescent lamp
<b>Airflow at High Speed:</b>	5380 CFM
<b>Electricity Usage:</b>	65W
<b>Airflow Efficiency:</b>	83 CFM/W
<b>RPMs (High/Med/Low):</b>	180/135/85



## Dimensions

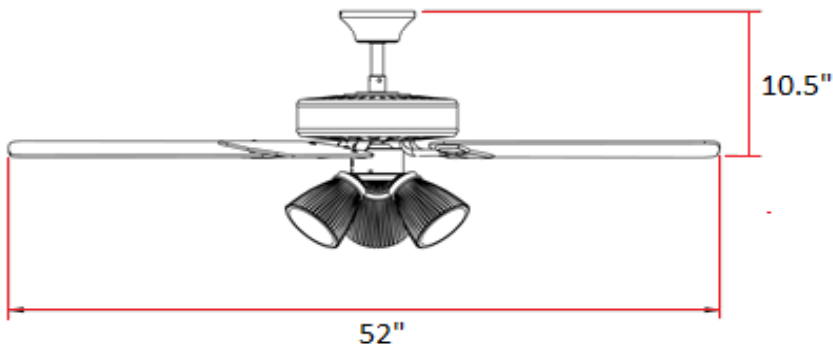

## Warranty & Compliances

<b>Warranty</b>	10 Year Limited Warranty
<b>UL</b>	UL Listed
<b>EnergyStar</b>	Qualified



## Companion Fixtures

**Satin Nickel** 154229

Type:

Job:

Order Code:

Approvals:

Design House reserves the right to make changes in materials, specifications & models at any time. Design House also reserves the right to discontinue product without notice or obligation.