

## WALLPACK LIGHT

## SPEC SHEET



Catalog No. : PWRW50-PC-4K-BZ

Type : Wallpack Light

Project Name :

Location :

Qty :

Date :



PROBRITE's Outdoor High-Output LED Wall Pack and Area Security Light with integral Dusk to Dawn photocell features high-performance LEDs saving 85% on energy bills. Its dimensions match most 150-Watt traditional metal halide commercial wall packs allowing for easy upgrades and replacements. Dimming feature enables the user to control the amount of light output, from ambient to high-output brightness of 6,800-Lumen. The Dual-Control Enabled feature allows for both Dusk to Dawn operation for automatic nighttime on/daytime off ensuring efficient energy usage or normal Switch-Controlled operation for more hands on control.

### APPLICATIONS

Ideal for both residential and commercial applications requiring high brightness and a large coverage area. Perfect for wall perimeter lighting, garages, large backyards, commercial loading bays, warehouses, apartment complexes, hotels, office and retail complexes.

### PRODUCT PERFORMANCE AT A GLANCE

SYSTEM WATTAGE	LED WATTAGE	LUMENS	LP/W	CRI	REPLACES (MH)
50W	45W	6800 lm	136 lm/w	≥70	175W



### HOUSING

High-grade commercial quality die-cast aluminum housing with UV-stabilized borosciliate prismatic glass lens, mounted with stainless steel hardware.

### OPTICS

Direct LED distribution with white reflective light distribution refractor. Prismatic glass lens reduces glare while providing even and wide light distribution.

### FINISH

Fade, weather, and abrasion resistant, electrostatically applied, thermally cured, triglycidal isocyanurate (TGIC) textured polyester powdercoat finish. Paint is dark bronze.

### IP RATING & LISTINGS

LED light engine is weather proof rated IP65.

DLC 4.3, cULus

### MOUNTING

Easy knock-outs on back box allows mounting to any standard 3 1/2" to 4" square and octagonal or 4 inch round electrical junction boxes. Can also be flush mounted to any surface and wired via conduit entries.

### WARRANTY

Fixture is covered by a 5-year limited warranty. See [probrite.com/warranty](http://probrite.com/warranty) for details.

## PRODUCT LINE DRAWING

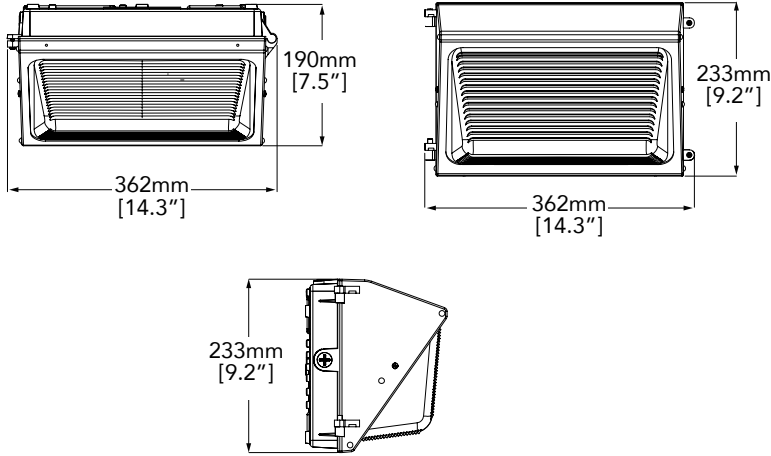

SUGGESTED MOUNTING HEIGHT:  
8-20FT. (2.4-6M)

## 3D PHOTOMETRIC VIEW

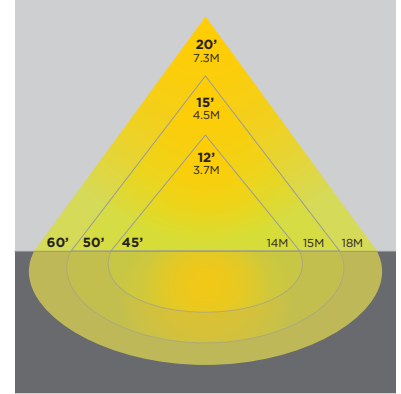

## 2D PHOTOMETRIC VIEW

MOUNTED AT 12FT.

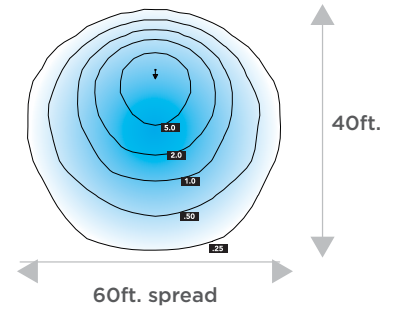

## PRODUCT SPECIFICATIONS

Product Dimensions	: 14.3" x 7.5" x 9.2"
Weight	: 12.12 lbs
Lumens	: 6800
System Wattage	: 50W
LED Wattage	: 45W
Efficacy	: 136
CRI	: 70
Replaces (MH)	: 175W
Mounting	: Wall
Frequency	: 50-60Hz
THD (Total Harmonic Distortion)	: <20%
PF (Power Factor)	: >0.9
Ambient Operating Temperature	: (-30) - 40°C
Input Voltage	: 120-277V
LED Chip	: HL-AT-2835FVW-S1-08-PCT-HR3
Photocell	: Yes
Driver	: 0-10V Dimming
Standard Lifetime	: L70 >50,000hrs
Standard Warranty	: 5 Years
Water Proofing Grade	: P66
CCT	: 4000K
Certifications	: DLC, UL/cUL

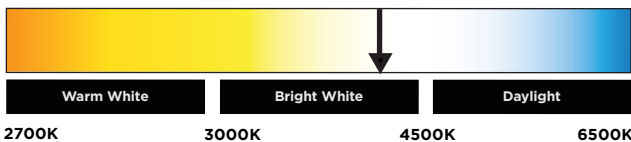

## APPLICATION

