



TORO®

Do-It-Yourself Irrigation Planning & Installation Guide

Your beautiful
landscape awaits...

INCLUDED INSIDE:

- **Toro Water Smart®
Irrigation Design Service**
- **Step-By-Step Sprinkler
Installation Instructions**
- **Water Saving Tips**
(See reverse for Spanish)





Toro Irrigation Systems Precise, Efficient, Practical.

Toro has been a leader in irrigation for over 45 years and has dedicated itself to providing homeowners innovative water saving solutions that are effective and easy to use—all with the Toro quality you can count on.

A Toro irrigation system will help you create the landscape you've always wanted by making sure your plants get the water they need, just when they need it. Other watering methods can use up to 50% more water than your yard needs. That isn't good for your lawn or your budget. The solution is precision watering using an irrigation system that can be adjusted to the individual needs of your landscape. As a result you will see thicker, greener lawns and more beautiful gardens as you save time and water.

This guide will walk you through how to take advantage of the Toro Water Smart® Design Service to plan a new system or upgrade an existing system. When you receive your irrigation design, use this guide for easy to understand, step-by-step installation instructions, too.

We encourage you to review this guide in its entirety before getting started. And don't worry—if you have any questions the experts at Toro are here to help.

For more information:

ONLINE ASSISTANCE

www.Toro.com
www.ToroDesign.com
www.ECXTRA.com

TOLL-FREE ASSISTANCE

Toro Technical Support **800-367-8676**
 The Toro Design Center **800-891-0742**

For maximum water savings and efficiency the Toro Design Service will incorporate drip irrigation into your design where applicable. For more information on drip irrigation design and installation please refer to the *Toro Blue Stripe Drip Planning & Installation Guide* available online at www.ToroDesign.com or at your local home improvement retailer.

Table of Contents

Using the Toro Water Smart® Design Service
NEW System Installation 3
UPGRADE an Existing System 3

How to Complete the Toro Water Smart® Design Questionnaire 4

Toro Water Smart® Design Questionnaires
NEW System Installation 5
UPGRADE an Existing System 6
 Property Plan Layout 7

Installing your Toro Irrigation System
 Before You Start 9
 STEP 1: Connect the Water Source 9
 STEP 2: Install Valves 10
 STEP 3: Connect Sprinklers and Piping 11
 STEP 4: Install the Timer 11

Water Smart® Tips 12



The Toro Water Smart® Design Service is exclusively for residential applications (homeowners and their personal property). Recommended products and specifications are limited to Toro irrigation products available in retail stores or online. Request for commercial property will be denied. Some residential design requests that are better suited to professional installation may be denied due to complexity or scale of the property.

Using the Toro Water Smart® Design Service

NEW System Installation

The first step in achieving a successful irrigation system is a good design. Properly designed sprinkler and drip systems decrease water consumption by improving the accuracy, timing and delivery of water, thereby reducing runoff and preventing over watering. This leads to better looking lawns and landscapes while preventing plant loss.

The Toro Water Smart® Design Service makes planning your system easy by creating a customized professional irrigation plan specific to your property's geography and landscape.

How the Water Smart® Design Service Works:

Using the Design Service is easy. All you need to do is provide us with a sketch of your property and a few details. Follow the simple directions on page 4 to complete the **NEW System Installation Questionnaire** (page 5) and create a property sketch (page 7). Once completed, email, mail or fax the questionnaire and the property sketch to Toro, and a customized design will be prepared for you. Each design includes information on proper equipment placement throughout your yard, correct sprinkler selection, number of zones needed, ideal timer location and a complete shopping list of all the parts and accessories you need—even the amount of PVC or poly pipe your system will require. Designs are broken down by zone for ease of planning.

There are three Design Service options available:

- **FREE Standard Service**

A professional irrigation design will be emailed to you in PDF format within 7 business days*.

- **\$19.95 Premium Service**

A 22" x 34" professional irrigation design will be sent to your address within 7 business days and includes water source and pipe installation instructions* In addition, electronic files will be sent via email in PDF format.

- **\$39.95 Premium Express Service**

Receive your Premium Service plan within 2 business days* Designs received after 11:00 a.m. PST will be processed the following business day. Addresses with P.O. boxes are not eligible for express service.

*Additional design time may be required depending on the complexity of the project.

UPGRADE an Existing System

Did you know that an outdated or poorly designed irrigation system can result in water waste, unhealthy plant growth, dry or patchy lawn and a host of other common landscape problems? In many cases, upgrading the layout and components in your irrigation system can be the solution. In addition, a more up to date irrigation system means a more efficient system—saving you money.

Water conservation has increasingly become an important focus for the irrigation industry. If your system was installed 5 years ago or more you may be missing out on important water saving irrigation products that will result in more efficient water delivery and savings.

The Toro Water Smart® Design Service can upgrade your existing irrigation system to a water efficient system using the best Toro Water Smart® products available.

How the Water Smart® Design Upgrade Service Works:

Follow the simple directions on page 4 to complete the **UPGRADE an Existing System Questionnaire** (page 6) and create a property sketch (page 7). Once completed, email, mail or fax the questionnaire and the property sketch to Toro, and a customized water savings design will be prepared for you.

Each design includes information on proper equipment placement throughout your yard, correct sprinkler selection, number of zones needed, ideal timer location and a complete shopping list for all the parts and accessories you will need. Designs are broken down by zone for ease of planning.

This **\$39.95 Water Smart® Design Upgrade Package** Includes:

- 22" x 34" professional irrigation design
- Electronic files sent via email in PDF format
- Complete shopping list to upgrade your system
- Detailed installation instructions
- A custom watering schedule that tells you when to water and for how long to achieve the most efficient results.

Design time will vary depending upon the complexity of the project. A Toro Water Smart® Advisor may request a brief telephone consultation to discuss your specific needs.

How to Complete the Toro Water Smart® Design Questionnaire

1 Draw Your Property to Scale

Use the Property Sketch Sheet (page 7). Each small square on the graph paper should represent one square foot of actual property or use a scale such as 1" = 10', 1" = 20', etc. Using a tape measure, measure your property and draw it to scale on the graph paper (see sample drawing on page 8).

1. Outline your house, garage, and other structures.
2. Show walkways, drives, slabs, patios and other surfaces.
3. Identify trees or major obstacles.
4. Measure and record the perimeter of your property.
5. Identify slopes.
6. Show ground cover, grass, flower beds and landscaping.
7. Identify the location of the water meter (or pump) and main line.

Additional grid paper is available at www.ToroDesign.com.

2 Determine Your Soil Type

You can easily determine your soil type—sand, loam or clay—using a clean empty jar with a lid, clean tap water, a tablespoon of detergent and a sample of the soil from your yard.

1. Fill the jar about ½ full with the soil to be tested.
2. Add water and detergent and cap the jar.
3. Shake the jar vigorously and set aside for several hours.
4. Evaluate the results and record on the questionnaire.

Sand Soil: Water is clear and soil has settled to the bottom of the jar.

Loam Soil: Water is still murky with bits of suspended matter.

Clay Soil: Water is murky and there is a ring of sediment around the jar.

3 Determining the Service Line Size

Contact your local water company or wrap a piece of string around the pipe once and then measure the string. Use the chart below to determine the supply line size/diameter. Record the line size on the questionnaire.

Length of String	2¾"	3¼"	3½"	4"	4¾"	5"
Copper Service Line	¾"		1"		1¼"	
Galvanized or PVC		¾"		1"		1¼"

If you have specific concerns please note them on a separate sheet of paper and submit along with your questionnaire and scale drawing.

4 Determine Your Water Pressure and Flow

Water pressure and flow can be determined using a Flow & Pressure Gauge or by performing a bucket test and using a standard pressure gauge.

Using a Toro Flow and Pressure Gauge

The Toro Flow and Pressure Gauge is designed to measure water pressure up to 160 PSI and water flow up to 13 GPM. The gauge is not intended for use on lines larger than one inch.

Measure static pressure:

1. Ensure all water inside the home is turned off.
2. Attach the flow gauge to the outdoor faucet closest to where the main line enters the house.
3. Ensure that the gauge is completely closed.
4. Open the outside faucet slowly.
5. When the outdoor faucet is fully open, read the static pressure and record it on the questionnaire.

Measure dynamic pressure and gallons-per-minute (GPM):

1. Open the flow gauge slowly. (*The static reading will drop and the GPM will rise as the gauge is opened.*)
2. Continue to open the gauge until pressure drops to 50 PSI.
3. Record the GPM at 50 PSI on the questionnaire.
4. Continue to close the gauge to 45 and 40 PSI and record the GPM readings.

If the pressure does not drop to 40 PSI or is above 50 PSI after opening the flow gauge all the way, then take the flow and pressure reading at the full open position. If rapid fluctuation occurs on the flow gauge, record the average reading.

Using a Bucket and Standard Pressure Gauge

1. Locate the outdoor faucet closest to the water supply line (Call this Faucet 1).
2. Select a different outdoor faucet on the house and attach a pressure gauge (This will be Faucet 2).
3. With Faucet 1 closed, open Faucet 2 all the way and record the static water pressure on the questionnaire.
4. With Faucet 1 open all the way, check the pressure reading on the gauge at Faucet 2. (*If less than 40 PSI, turn down the water flow from Faucet 1 until the reading reaches 40 PSI.*)
5. Place a 5 gallon bucket under Faucet 1 and time how long it takes to fill it. Use the chart below to convert to GPM to determine the water capacity at 40 PSI.
6. Repeat this procedure at 45 PSI and 50 PSI and record the results on the questionnaire.
7. If pressure is greater than 50 PSI record that reading.

TIME TO FILL BUCKET	GALLONS PER MINUTE
15 seconds	20 GPM
20 seconds	15 GPM
25 seconds	12 GPM
30 seconds	10 GPM
40 seconds	7.5 GPM

Toro Water Smart® Design Questionnaire: **NEW** System Installation

DESIGNS ARE INTENDED FOR USE WITH TORO PRODUCTS ONLY.

To receive a Toro Water Smart® irrigation design for a new system installation complete the following and email, mail or fax to Toro along with a sketch of your property.

Please **PRINT CLEARLY** and fill out the form completely. All information must be properly supplied before we will be able to design your system. Your design and the recommended parts list will be based on the accuracy of the information we receive.

NAME _____

ADDRESS _____

CITY _____

STATE _____ ZIP _____

DAYTIME PHONE NUMBER _____

EVENING PHONE NUMBER _____

EMAIL ADDRESS _____

For e-mail notification when your design is complete

RETAIL STORE WHERE YOU WILL BE PURCHASING PRODUCT:

We will attempt to ensure that most recommended parts and products can be purchased from your retailer of choice.

PAYMENT METHOD: VISA MasterCard

We are unable to accept checks, money orders, debit cards, Discover or American Express

CARD NO. _____

EXP. DATE: MO _____ YR _____

PLEASE NOTE: Homeowner is required to tap into water source and comply with local codes and permits. Before digging or trenching, check with your local utility companies to identify any buried cables, pipe or gas lines.

DISCLAIMER: The Toro Sprinkler Design and parts are recommended to customer based solely on the information, dimensions and drawings provided to Toro by the customer. Toro has not inspected customer's property landscape, sun exposure or soil conditions. Toro has no control over whether recommended Toro parts or sprinkler system design are properly purchased, installed, used or maintained. Toro shall have no liability, and disclaims any and all liability, arising from or with respect to the design, purchase and/or installation of the sprinkler systems. For specific warranty on Toro products, go to www.Toro.com.

MAIL PROPERTY SKETCH AND QUESTIONNAIRE TO:

**Toro Water Smart® Design Center
5825 Jasmine Street, Riverside, CA 92504**

FAX TO: (800) 504-4978

EMAIL TO: DesignService@Toro.com

If you have any questions feel free to call (800) 891-0742 or visit our web site at www.ToroDesign.com.

1. Scale of Drawing: _____ Inch = _____ Feet

2. Water Meter Size: 5/8" 3/4" 1"

3. Water Supply Line: Copper Galvanized
 PVC PEX (Poly)

4. Water Supply Line Size: 3/4" 1" 1 1/4"

5. Water Pressure and Flow Readings:

Static water pressure _____ PSI

Gallons-per-minute: at 40 PSI: _____

at 45 PSI: _____

at 50 PSI: _____

If PSI is greater than 50: _____ PSI _____ GPM

6. Pump Information

If you use a pump, it is recommended that it produce a minimum of 45 PSI @ 10 GPM for a sprinkler system. If your pump is not adequate, call for advice or write "will purchase new pump" on your layout. We will design your system using the pump output recommended for your property.

7. Soil information: Sandy Loam Clay

8. Install timer: Indoors

9. Irrigation water: Clean Containing Sediment

10. Does the ground freeze? Yes No

11. Please select a service option:

Standard Service – FREE

Your professional irrigation design will be sent to you in Adobe PDF® format via email within 5 to 7 business days**

Premium Service – \$19.95

A 22" x 34" professional irrigation design will be sent to you within 5 to 7 business days** Additionally, electronic files will be sent via email in Adobe PDF® format.

Premium Express – \$39.95*

Includes Premium Service package designed and shipped within 2 full business days** NO P.O. BOXES PLEASE.

**Prices are based on shipping within the Continental United States and are subject to change. Shipment to areas outside the Continental United States may be higher.*

***Additional design time may be required depending on the complexity of the project.*

Please double check to ensure that:

- Your property is drawn to scale
- All slopes are identified and show direction
- Water meter/pump location is indicated
- Timer and valve location is indicated
- All information on the questionnaire is complete

TORO®

THD-Web

Toro Water Smart® Design Questionnaire: **UPGRADE** an Existing System

DESIGNS ARE INTENDED FOR USE WITH TORO PRODUCTS ONLY.

To upgrade your existing irrigation system, complete the following and email, mail or fax to Toro along with a sketch of your property.

Please **PRINT CLEARLY** and fill out the form completely. All information must be properly supplied before we will be able to design your system. Your design and the recommended parts list will be based on the accuracy of the information we receive.

NAME _____

ADDRESS _____

CITY _____

STATE _____ ZIP _____

DAYTIME PHONE NUMBER _____

EVENING PHONE NUMBER _____

EMAIL ADDRESS _____

For e-mail notification when your design is complete

RETAIL STORE WHERE YOU WILL BE PURCHASING PRODUCT: _____

We will attempt to ensure that most recommended parts and products can be purchased from your retailer of choice.

\$39.95 PAYMENT METHOD: VISA MasterCard

We are unable to accept checks, money orders, debit cards, Discover or American Express

CARD NO. _____

EXP. DATE: MO _____ YR _____

PLEASE NOTE: Homeowner is required to tap into water source and comply with local codes and permits. Before digging or trenching, check with your local utility companies to identify any buried cables, pipe or gas lines.

DISCLAIMER: The Toro Sprinkler Design and parts are recommended to customer based solely on the information, dimensions and drawings provided to Toro by the customer. Toro has not inspected customer's property landscape, sun exposure or soil conditions. Toro has no control over whether recommended Toro parts or sprinkler system design are properly purchased, installed, used or maintained. Toro shall have no liability, and disclaims any and all liability, arising from or with respect to the design, purchase and/or installation of the sprinkler systems. For specific warranty on Toro products, go to www.Toro.com.

MAIL PROPERTY SKETCH AND QUESTIONNAIRE TO:

**Toro Water Smart® Design Center
5825 Jasmine Street, Riverside, CA 92504**

FAX TO: (800) 504-4978

EMAIL TO: DesignService@Toro.com

If you have any questions feel free to call (800) 891-0742 or visit our web site at www.ToroDesign.com.

1. Scale of Drawing: _____ Inch = _____ Feet

2. Water Meter Size: ½" ¾" 1"

3. Water Supply Line: Copper Galvanized
 PVC PEX (Poly)

4. Water Supply Line Size: ¾" 1" 1¼"

5. Water pressure and flow readings:

Static water pressure _____ PSI

Gallons-per-minute: at 40 PSI: _____

at 45 PSI: _____

at 50 PSI: _____

If PSI is greater than 50: _____ PSI _____ GPM

6. Pump Information

If you use a pump, it is recommended that it produce a minimum of 45 PSI @ 10 GPM for a sprinkler system. If your pump is not adequate, call for advice or write "will purchase new pump" on your layout. We will design your system using the pump output recommended for your property.

7. Soil information: Sandy Loam Clay

8. Irrigation water: Clean Containing Sediment

9. Does the ground freeze? Yes No

10. Please indicate the type of sprinkler currently installed:

Spray head Gear Rotor Impact Rotor

11. Please indicate the brand and model of sprinkler currently installed (i.e. Toro 570): _____

12. Please indicate the type of valve currently installed:

Anti-siphon In-line

13. Valve size: ¾" 1"

14. Please indicate the brand(s) and model(s) for valves currently installed (i.e. Lawn Genie Model L7010): _____

15. Main Line Size: ¾" 1" 1¼"

16. Lateral Line Pipe:

PVC Schedule 40 PVC Class 200 Poly

17. Lateral Line Size: ¾" 1"

18. Timer: _____ Number of Stations/Zones

Please double check to ensure that:

- Your property is drawn to scale
- All slopes are identified and show direction
- Water meter/pump location is indicated
- Timer and valve location is indicated
- Sprinkler location(s) are indicated
- Indicate which sprinklers are connected to each valve
- Indicate overly dry or wet areas
- All information on the questionnaire is complete
- Any sleeves/conduits and size of pipe inside is identified





Property Sketch Sheet

See sample drawings on page 8.
Additional sheets available at www.ToroDesign.com.

Your name: _____ Scale of Drawing: _____ Inch = _____ Feet

Designs must be to scale and cannot exceed 11" x 17".

New System Sample Drawing

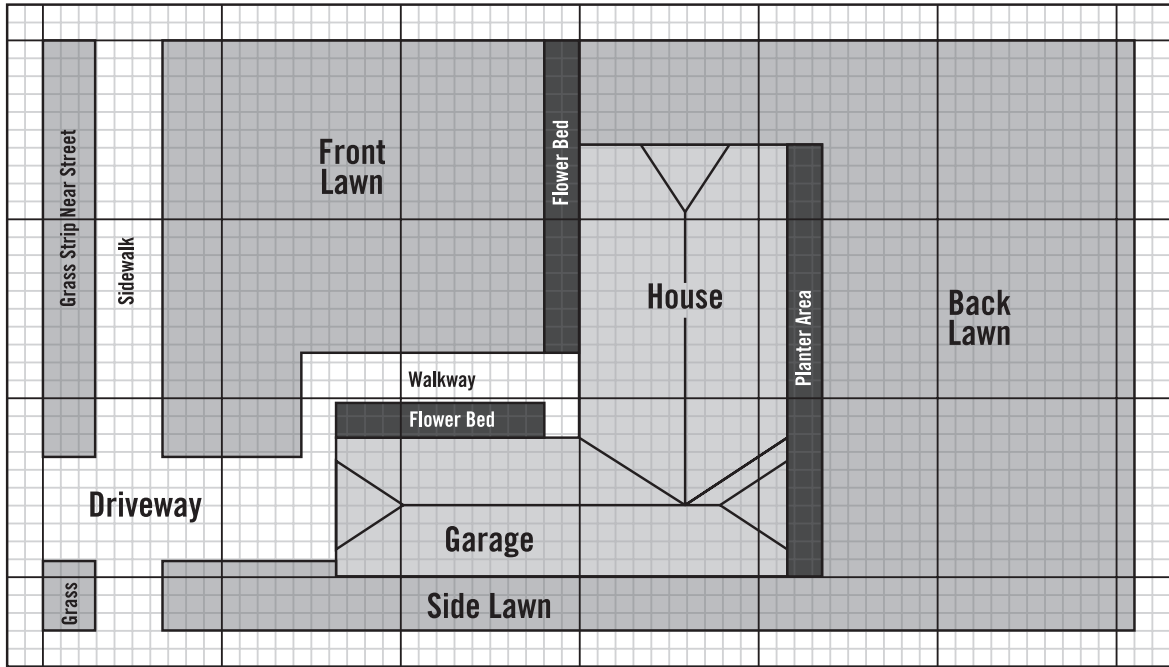

Existing System Sample Drawing

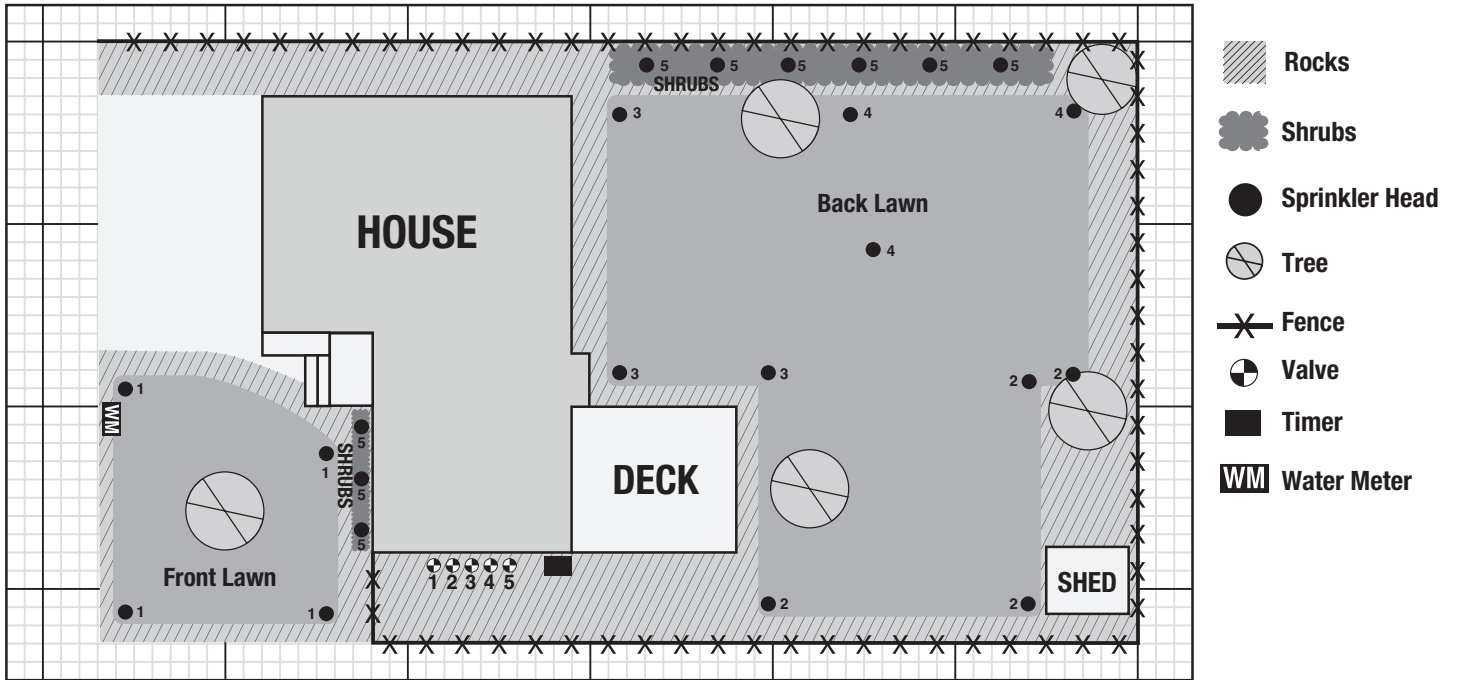

Installing your Toro Irrigation System

Before You Start

Check local codes to ensure that you have secured all necessary permits. In addition, have your local utilities mark all the buried lines and pipes before you start digging. In many areas, simply dialing 811 will connect you with one resource that will arrange to have all your utilities marked. Otherwise, contact your local utility provider(s) directly.



Tools and Supplies

In addition to the Toro parts called for on your irrigation design you may need additional installation tools and supplies. Use the list below as a guideline:

- PVC Pipe Cutter
- Screwdriver
- Pipe Wrenches
- Hammer
- Trenching Shovel
- Line Marking Paint
- Poly Pipe Clamps
- Poly Pipe Crimper
- PTFE Tape
- Tape Measure
- Solvent, Primer, Rags
(PVC only — do not use pipe glue on plastic-threaded fittings.)
- Marking Flags
- Grease Cap/Water-Proof Wire Connectors
- 18-gauge, multi-strand direct burial wire

STEP 1: Connect the Water Source

MARK YOUR SPRINKLERS, RISERS, VALVES & TRENCHES

Use marking flags to indicate sprinkler locations according to your design. Also, mark the location of your drip system risers, if applicable. Even if you plan to install the drip system at a later date, you can install your drip risers with the rest of your system now. Use line-marking spray paint to mark where you'll trench for pipes and wiring. Check your design to make sure you mark the lines accurately. You will be digging your trenches along these lines.

TAP INTO THE MAIN LINE

By cutting into your service line and slipping on a compression tee, you can connect your irrigation system to the water supply without soldering. Depending upon the location of your water meter, the steps that follow will guide you through tapping into the main line.

Additionally, we recommend installing a shut-off valve between the zone valves and the service line. This will allow you to easily turn off the water to your irrigation system if you need to make repairs or replace parts. Check local codes for the type of shut-off valve recommended.

Cold Climates: If you live in an area where freezing occurs, it is best to contact a professional to winterize your system in the fall. However, to make attaching the air line for blowing out your system easier, add a tee in the main supply line (S x S x T) between the Pressure Vacuum Breaker (PVB) and valve manifold. Screw a cap onto the extra leg.

A. If the meter is in your yard:

1. Shut off your water supply at the meter.
2. Dig to expose the service line.
3. Tie into the service line, between the water meter and the house.
4. Remove a section of pipe, leaving a gap large enough to slide on the compression tee.
5. Slip the tee over each end of the pipe.
6. Tighten the compression nuts. The rubber gasket will compress against the pipe, creating a seal to prevent leakage.
7. Install a short nipple, using PTFE tape on all threaded connections to the tee.
8. Attach a shut-off valve, in a small enclosure, to this section of pipe. The shut-off valve allows you to turn off the system by hand, if necessary. *This is your tap water supply so try to keep the connection as clean as possible.*

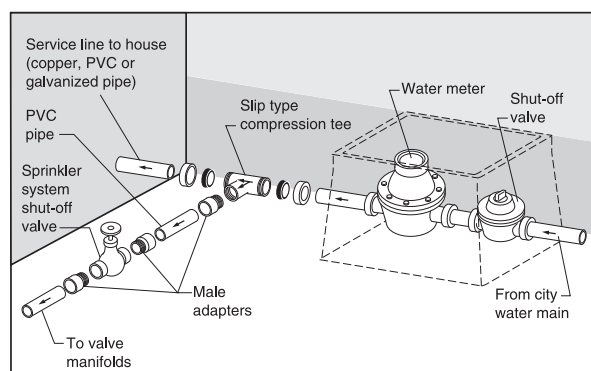

B. If the meter is in your basement:

1. Shut-off your water supply at the meter.
2. Install an appropriate tee into the service line for the irrigation connection.
3. Drill a hole through the sill above the foundation, or chisel a hole in the basement wall for the irrigation line to run through. Make the hole no larger than necessary for the pipe specified on your design.
4. Install the connection fittings, as shown below. A ball valve is a good choice for the irrigation shut-off. For the drain valve, use a gate-type valve. The drain valve should be as low as possible to allow complete system drainage.
5. Feed your irrigation system pipe out through the basement wall, and run it to the backflow preventer location.
6. Seal the hole in the sill or foundation with caulking compound.

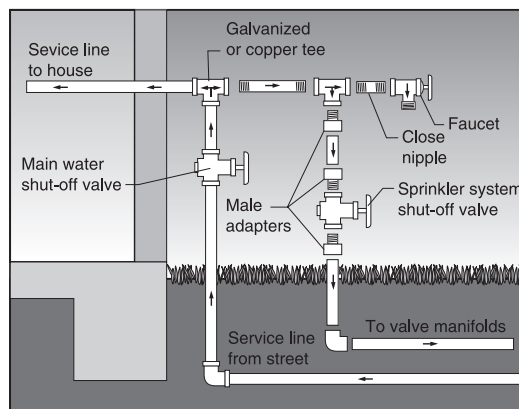

MAIN AND LATERAL LINE TRENCHING

Remember to have all utilities marked before you begin trenching to prevent serious injury. Call your local utilities or dial 811. To soften the soil when trenching with a shovel, water the ground approximately two days before you dig. Dig trenches 8" to 12" deep. Put sod on one side of the trench and soil on the other.

Trenching machines are an easier, faster alternative to digging with a shovel. Typically, Toro trenching machines can be rented from a lawn supply store or rental equipment dealer. The store or dealer can show you how to operate the machine properly.

In cold or freezing climates, where poly pipe is used instead of PVC, a vibratory plow is used for pulling pipe. Deeper trenching may also be necessary.

INSTALL THE SYSTEM MAIN LINE

Attach the main line to the service line. Run it along the bottom of the trench from the house to the first set of valves, and if necessary, to the second set of valves. Place the valve wires under the pipe in the bottom of the trench whenever possible.

A. Working with PVC Pipe:

1. Cut pipe with a PVC pipe cutter.
2. Brush on a primer to clean the pipe surface and the inside of the fitting.
3. Brush glue on the outside end of the pipe lightly inside the fitting.
4. Slip the pipe into the fitting and give it a quarter turn.
5. Hold in place for about 15 seconds so the glue can set.
6. Wipe off excess glue with a rag.
7. Wait at least one hour before running water through the pipe (*check manufacturer's recommendations*).

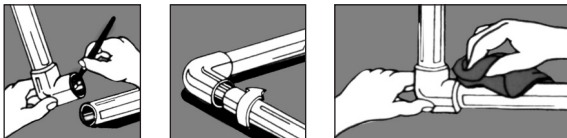

B. Working with Poly Pipe:

Do not use poly pipe as a connecting pipe between the service line and the control valves. Surge pressure may rupture the pipe. Check your local codes for the correct type of pipe to use.

1. To relax poly pipe, expose it to sunlight. (*Never expose to open flame.*)
2. Cut pipe with a PVC or poly pipe cutter.
3. Slip a stainless-steel clamp over the end of the pipe.
4. Insert the barbed fitting into the end of the poly pipe, past the barbs.
5. Slide the clamp over the barbs of the fitting.
6. Tighten the clamp.

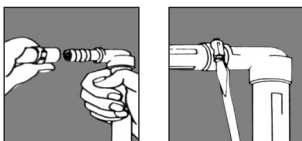

STEP 2: Install Valves

BUILD VALVE MANIFOLDS

A group of valves is called a valve manifold. Use flags to mark the location of the valves as indicated on your irrigation design.

A. Anti-Siphon Valve Installation

Anti-siphon valves are a combination of a valve and atmospheric backflow preventer and are always installed above ground. Some sort of backflow prevention is required on every irrigation system so check building codes in your area to find out if an anti-siphon valve will work for you. Dig out an area large enough to accommodate your inlet and outlet pipes.

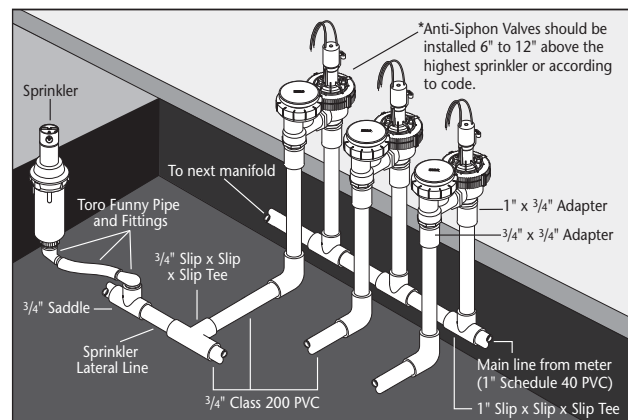

B. In-Line Valve Installation

In-line valves are installed below ground and require a separate backflow device. Protect valves below ground by sheltering them in a valve box. Dig out the area where the valves are to be installed. Install the valve box at or below grade level. When purchasing a valve box, be sure to find out how many valves fit in each box so that you can be sure to purchase the correct number of boxes. In some cases, you will need more than one valve box per manifold.

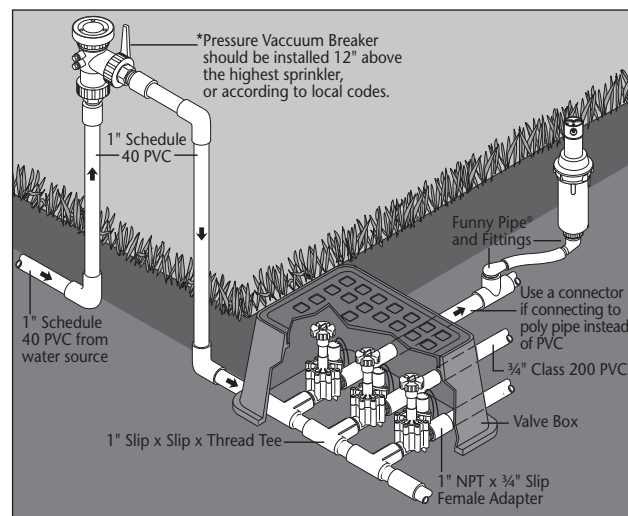

SHUT-OFF VALVES

We recommend installing a shut-off valve between the zone valves and the service line. This will allow you to easily turn off the water to your irrigation system if you need to make repairs or replace parts. Check local codes for the type of shut-off valve recommended.

STEP 3: Connect Sprinklers and Piping

INSTALL LATERAL PIPE

Start from the valve and move outward, laying the connecting pipe along the bottom of the trench (more than one pipe may be laid in a trench). At each flag, install a tee or elbow fitting, and if needed, a riser for sprinkler attachment. We recommend that you use Toro Funny Pipe® for all your sprinkler head installations.

INSTALL SPRINKLERS ZONE-BY-ZONE

Using your irrigation design as a reference, install the sprinklers one zone at a time, using Toro Funny Pipe® to connect to the lateral lines.

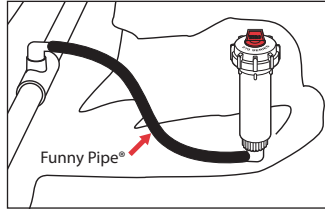

1. Place a sprinkler in the trench as a guide and measure from the connecting pipe fitting to the bottom of the sprinkler. Cut a length of Funny Pipe® to fit. (Place sprinklers at least 3" from sidewalks and curbs and 6" from fences and buildings.)
2. Install the appropriate Funny Pipe® elbow into the sprinkler and PVC or poly pipe fitting. No glue or clamps are needed.
3. Connect the Funny Pipe® to the sprinkler and pipe fitting. (Do not use more than 4' of Funny Pipe® with each sprinkler.)
4. Position the sprinkler in the trench so that the top of the sprinkler is flush with the ground. Stabilize the sprinkler with the soil but do not fill the entire trench.
5. Verify the sprinkler is vertical for optimum performance.
6. Repeat this process for each sprinkler.

FLUSH THE SYSTEM TO CLEAR DEBRIS

After the pipe has been connected and the glue has dried (PVC only), turn on the water, open the valves one zone at a time and flush the water until it runs clear. *If your sprinklers have nozzles pre-installed, remove the nozzles for flushing.*

INSTALL SHRUB HEADS AND BUBBLERS

Shrub heads and bubblers should be mounted on risers that lift them several inches above the soil surface. This allows the spray patterns to reach maximum radius.

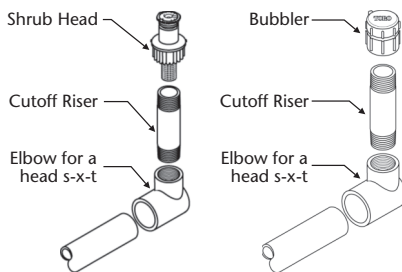

ADJUST THE SPRAY COVERAGE

Turn on each valve, one at a time, to make sure that you are getting the proper coverage. If not, the sprinklers may need to be adjusted. Also, most valves include a flow control feature that reduces wasteful misting and fogging. Follow the instructions included with the valve to adjust the flow control feature. If the flow controls are at their maximum and the sprinklers are not throwing water as far as they should, you may have too many sprinklers on that valve or line. Double check to be sure that the installation matches the recommended design.

STEP 4: Install the Timer

1. Install the timer in your garage or other convenient location. For outdoor installation be sure to use an outdoor cabinet to protect the timer against the effects of weather. Make sure an adequate power supply is available. *All outdoor electrical connections must be waterproofed. Use grease caps for water proof wire connections. See instructions included with the timer for details.*
2. If you haven't already done so, lay the valve wires in the bottom of the trenches, beneath the pipes.

Installing more wire strands than your system currently requires can be a real time saver. Adding them now is simple; adding them later after all the dirt is back in place and the grass is growing is not.

3. Connect the valves to the timer using the valve wires.
 - a. Take one wire from each valve and connect them to a common wire. (For ease of identification, use the white wire as the common.)
 - b. At the timer, connect the common wire to the common terminal on the timer.
 - c. Take the other wire from each valve and connect them to the timer terminals in sequence.
4. Plug in the timer and program per manufacturer's instructions.
5. For help creating a watering schedule download EC•XTRA™ Scheduling Advisor™ software at www.ECXTRA.com.

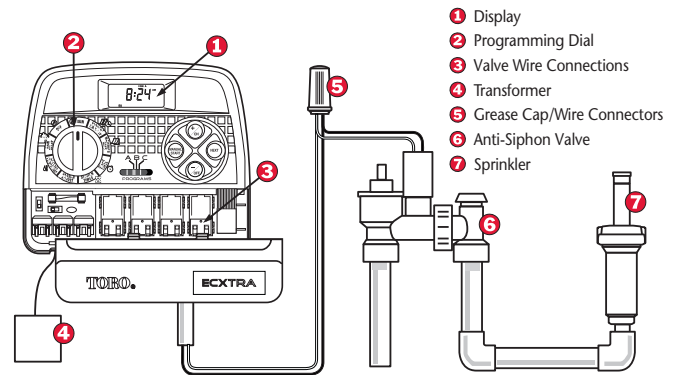

OPTIONAL: Connecting a Pump Start Relay

If your system will get water from a well, water tank or pond, a pump start relay lets you automatically activate the pump if your water supply requires one. For proper function, the timer must be installed at least 12' from the pump and 5' from the pump start to prevent malfunctions.

For expanded installation instructions visit www.ToroDesign.com.

Congratulations, installation is complete!



Water Smart® Tips



Install a rain sensor to automatically prevent watering when it rains. Check with your local water authority for rebates on rain sensor installations.



Include drip irrigation in gardens, planters and beds. Drip irrigation can save up to 70% in water usage due to more efficient delivery.



In hot weather keep grass taller. This will lessen the soil's exposure to the sun and allow the soil to hold on to moisture for a longer period of time.



Prevent water waste—adjust sprinklers to avoid watering walkways, sidewalks and buildings.



Use mulch or bark in beds and planters to reduce sun exposure and water loss through evaporation. This also helps prevent weed growth.



Optimize water usage and prevent over watering by using Toro XTRA SMART™ Scheduling Advisor™ Software to customize a watering schedule for your landscape.

