



Intelligent Design™

Model: AD5030, AD5031  
AD6030

**Step 1**

Unfold chair assembly

**Step 2**

Insert (2) 2 1/4" bolts, washers and locknuts into pre-drill holes  
Then insert pins

**Step 1**

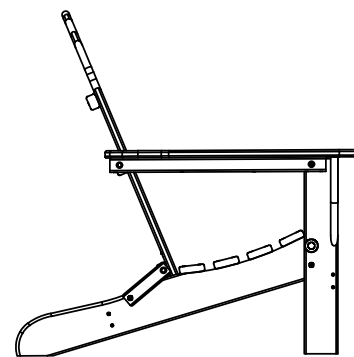

Correct

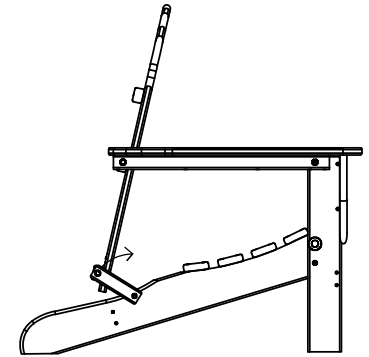

Incorrect

**TOOLS NEEDED**

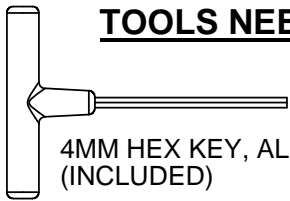

4MM HEX KEY, ALLEN, T-HANDLE  
(INCLUDED)

Qty.	Description
------	-------------

2	3/4 X 2 ADIRONDACK PIN HDPE
---	-----------------------------

2	A - 1/4-20 X 2-1/4 WAFER SHCS
---	-------------------------------

2	B - 1/4 FLAT WASHER
---	---------------------

2	B - 1/4-20 NYLOCK NUT
---	-----------------------

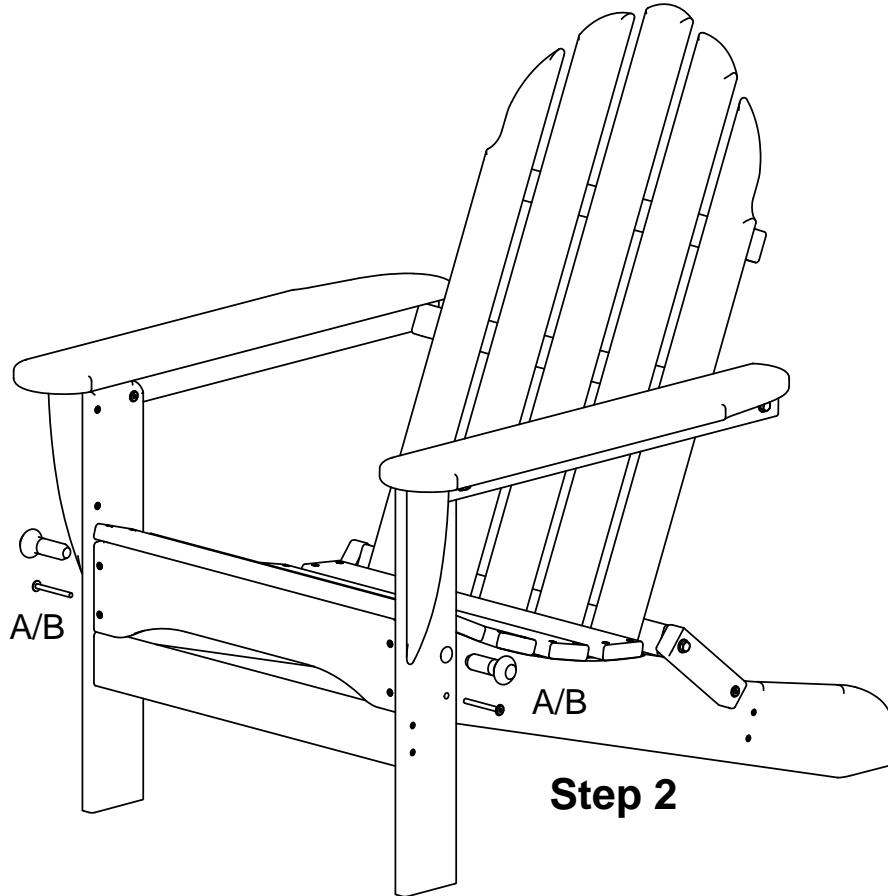

**Step 2**

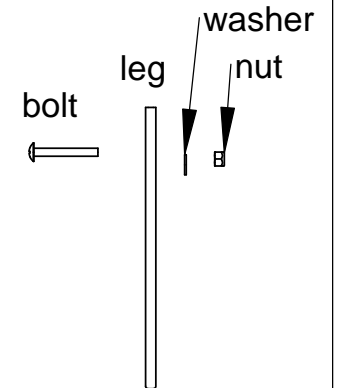



Intelligent Design™

Model: RCT38, RKT38

- (1) Table top
- (4) Legs
- (2) Short Brace
- (2) Long Brace
- (1) Hardware pack

**TOOLS NEEDED**

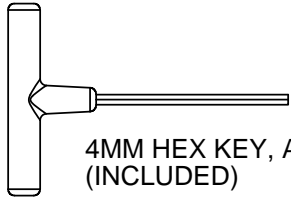

4MM HEX KEY, ALLEN, T-HANDLE (INCLUDED)

**Step 1**  
 Lay table top on flat surface.  
 Attach legs to table top and braces to legs  
 using (8) 2 1/2" screws.

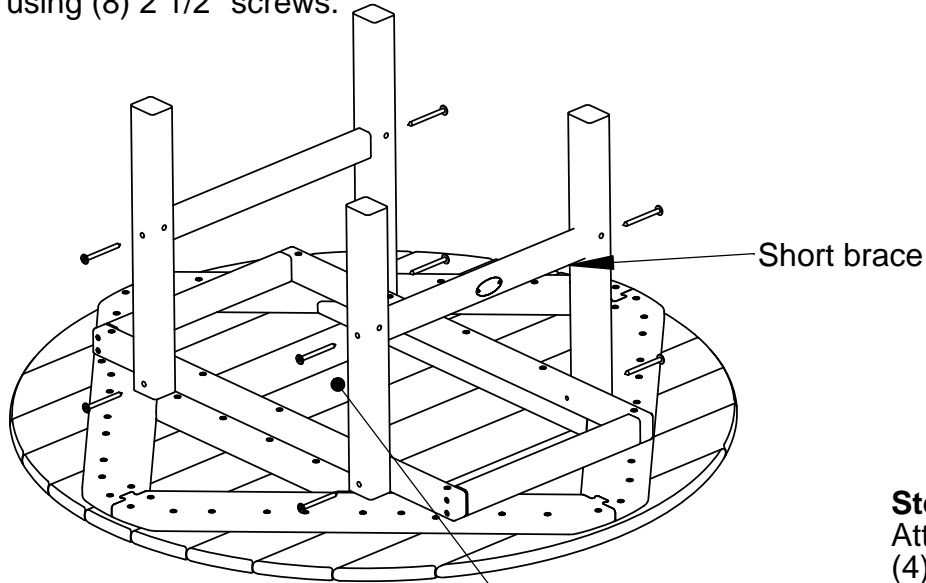

Removable table plug included in table.

**Step 2**  
 Attach braces to legs using  
 (4) 2 1/2" screws.

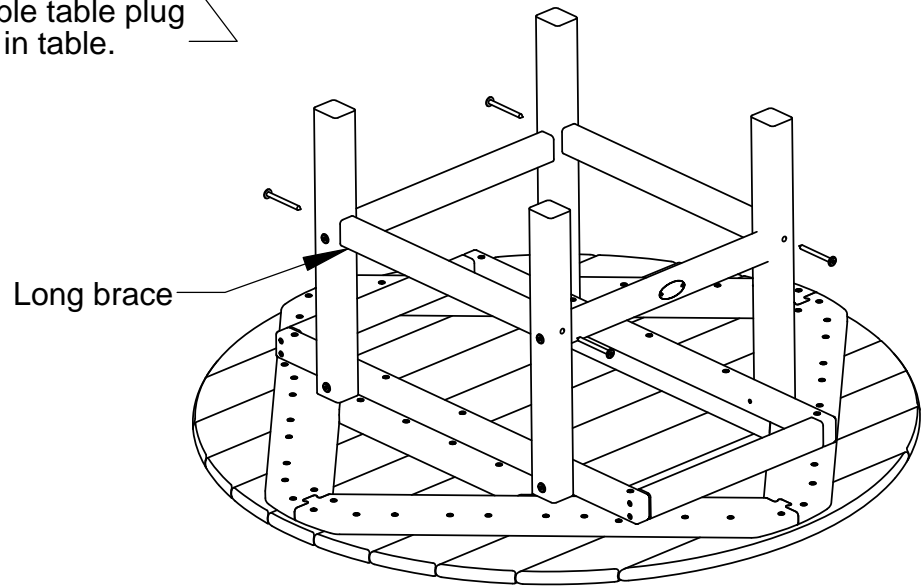

Qty.	Description
12	.27 X 2-1/2 SOCKET WAFER A

