

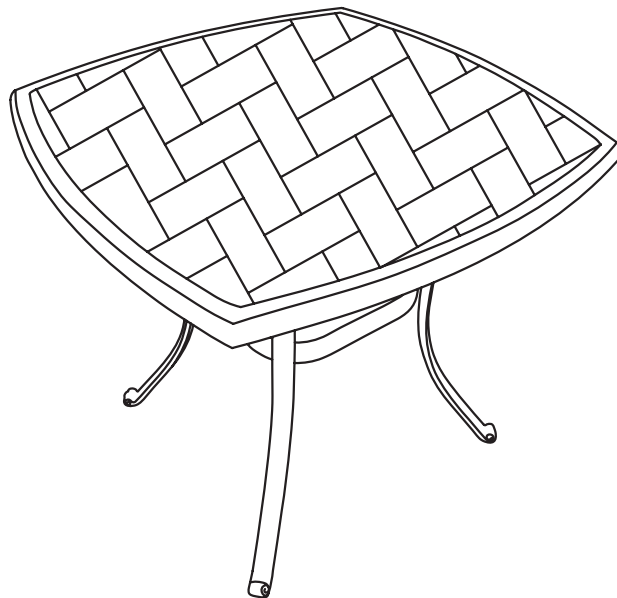

Item # 1001 857 637
Model # D11334-TS

USE AND CARE GUIDE

BELCOURT ACCENT TABLE



Questions, problems, missing parts? Before returning to the store,
call Hampton Bay Customer Service
8 a.m. - 7 p.m., EST, Monday-Friday
9 a.m. - 6 p.m., EST, Saturday

1-855-HD-HAMPTON

HAMPTONBAY.COM

THANK YOU

We appreciate the trust and confidence you have placed in Hampton Bay through the purchase of this accent table. We strive to continually create quality products designed to enhance your home. Visit us online to see our full line of products available for your home improvement needs.

Thank you for choosing Hampton Bay!

Table of Contents

Table of Contents.....	2	Assembly.....	5
Safety Information.....	2	Care and Cleaning.....	6
Warranty.....	2		
What is Covered	2		
What is Not Covered.....	2		
Pre-Assembly.....	3		
Planning Assembly	3		
Hardware Included	3		
Table Package Contents.....	4		

Safety Information



WARNING: Do not sit or stand on the table top.



WARNING: Do not place heavy items on the table top.

Warranty

THIS IS A RESIDENTIAL WARRANTY ONLY. THIS WARRANTY DOES NOT APPLY TO COMMERCIAL USE.

5-YEAR FRAME LIMITED WARRANTY

WHAT IS COVERED

We warrant the frame to be free of manufacturing defects to the original purchaser for five years.

WHAT IS NOT COVERED

It remains the customer's responsibility for freight and packaging charges to and from our service center.

This warranty does not cover commercial use, hardware, acts of nature, fire, freezing and abusive use.

In addition, purchased parts are not covered under this warranty. We reserve the right to make substitutions with similar merchandise, if the model in question is no longer in production.

For a copy of our full limited warranty, please contact our customer service team at 1-855-HD-HAMPTON or visit www.hamptonbay.com.

Pre-Assembly

PLANNING ASSEMBLY

Please read this entire instruction manual prior to assembly. Identify all parts packed in the carton against the parts list. Remove all protective materials and place the parts on a non-abrasive surface to avoid scratching.



NOTE: More than one person may be required to assemble the product.

HARDWARE INCLUDED



NOTE: Hardware not shown to actual size.

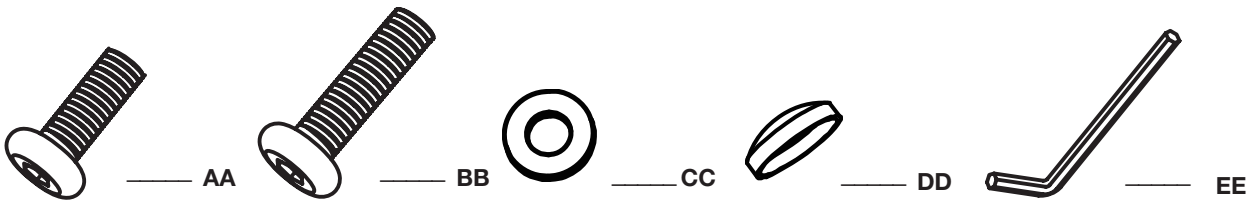

Part	Description	Quantity
AA	M6x15 mm Bolt	4
BB	M6x25 mm Bolt	8
CC	M6 Washer	12
DD	Bolt cap	12
EE	Hex wrench	1

Pre-Assembly (continued)

TABLE PACKAGE CONTENTS

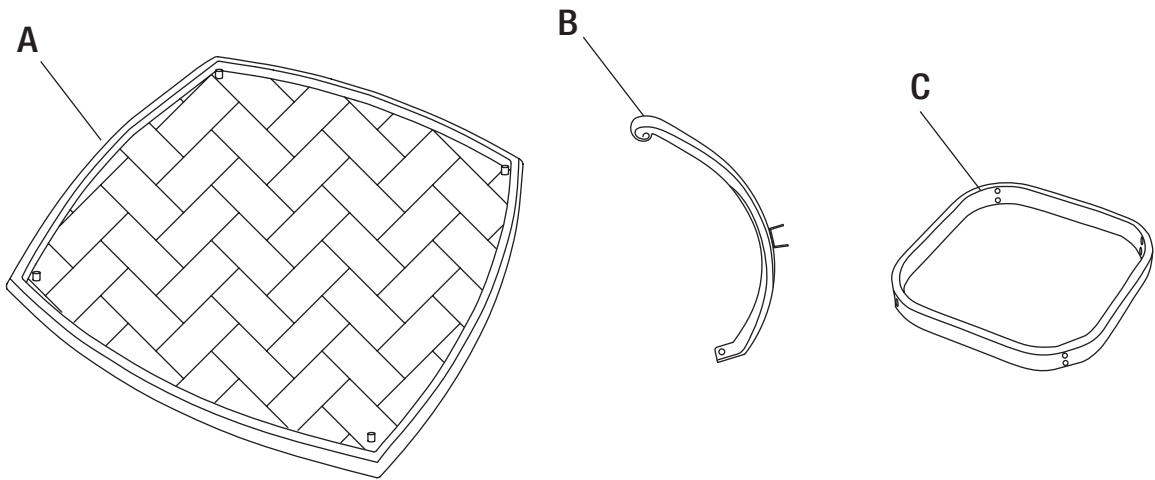

Part	Description	Quantity
A	Table frame	1
B	Table legs	4
C	Connector ring	1

Assembly

1 Attaching the table legs

- Place the table frame (A) upside-down on a soft, flat, non-abrasive surface. Attach the table legs (B) to the table frame (A) using M6x15mm bolts (AA) and M6 washers (CC). Do not fully tighten the bolts.

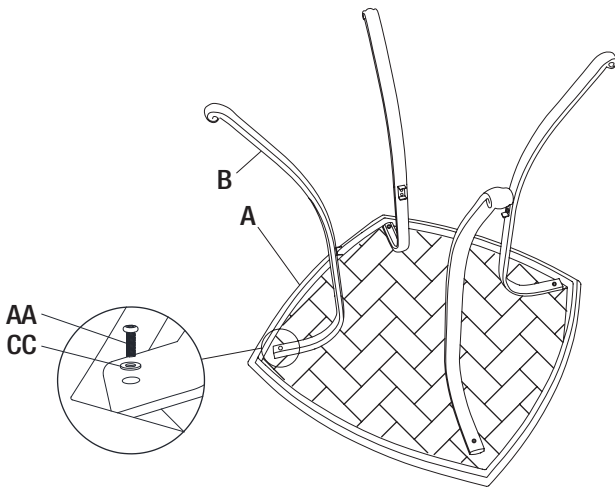

2 Attaching the connector ring

- Attach the connector ring (C) to the table legs (B) using M6x25 mm bolts (BB) and M6 washers (CC). Fully tighten all the bolts with the hex wrench (EE). Ensure all bolts are aligned and assembled correctly.
- Attach the bolt caps (DD) on all bolts.

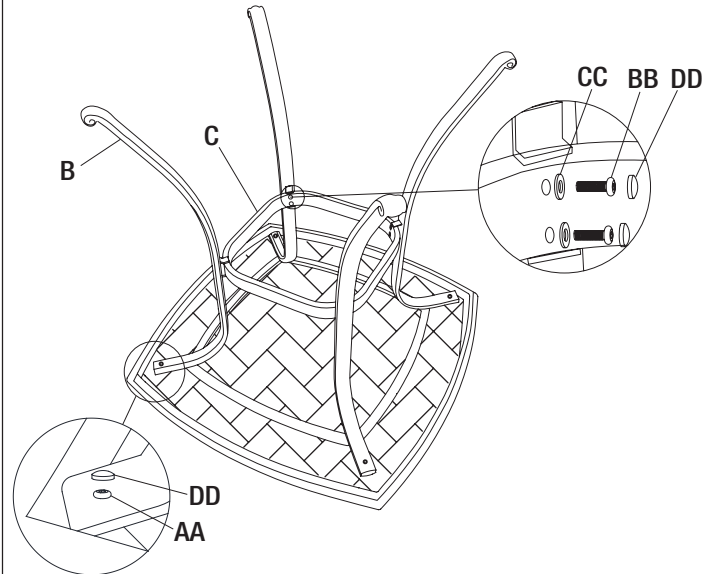

3 Positioning the table

- Turn the table right side up.

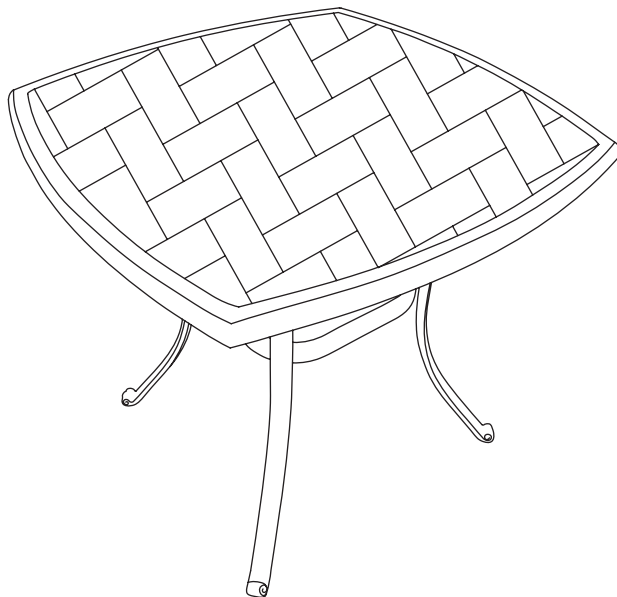

Care and Cleaning

- Do not allow water to build up on the table frame. This will cause corrosion and possible freezing damage in cold climates.
- Use a mild soap and water for normal cleaning. Do not use janitorial or alcohol based cleaners as the ingredients in some cleaners may cause discoloration or have an adverse reaction on your finish.
- Rinse with clean water and dry with a soft, absorbent cloth towel.
- Treat the frame with a liquid wax for maximum protection against UV rays and/or salty, damp air.



Questions, problems, missing parts? Before returning to the store,

call Hampton Bay Customer Service

8 a.m. - 7 p.m., EST, Monday-Friday

9 a.m. - 6 p.m., EST, Saturday

1-855-HD-HAMPTON

HAMPTONBAY.COM

Retain this manual for future use.