

# How To Assemble Your Rocking Chair (REV. 12/2016)







**TOOLS NEEDED:** Philips screwdriver, power drill optional

**CAUTION:** When assembling chair, **DO NOT** completely tighten the bolts and nuts until all the parts & holes are properly aligned.

- This chair is not recommended for weight of more than 250lbs.
- Care should be taken to avoid tipping while seated.
- This chair is designed for use on level ground only. Do not use on unlevel ground.
- To avoid harm or injury - do not sit on arms.
- Product is for residential use only - not meant for commercial use.





## PART LIST

When unpacking, please be careful not to discard any parts with the packaging. Before continuing, make sure you have the following parts:

| No. | Description | Qty | Sketch  | No. | Description | Qty | Sketch  |
|-----|-------------|-----|---|-----|-------------|-----|---|
| A   | Seat        | 1   |  | E   | Left Arm    | 1   |  |
| B   | Front Frame | 1   |  | F   | Right Arm   | 1   |  |
| C   | Back        | 1   |  | G   | Runner      | 2   |  |
| D   | Rail        | 2   |  |     |             |     |   |

## HARDWARE LIST

When unpacking, please be careful not to discard any hardware with the packaging. Before continuing, make sure you have the following hardware:

| No. | Description   | Qty | Sketch   | No. | Description            | Qty | Sketch  |
|-----|---------------|-----|--|-----|------------------------|-----|---|
| I   | Bolt          | 4   |  | L   | Long Screw<br>Ø4x45mm  | 10  |  |
| J   | Spring Washer | 4   |  | M   | Size:2<br>Hexagon Head | 2   |  |
| K   | Allen Wrench  | 1   |  | N   | Allen Wrench           | 1   |  |

### Step 1:

Attach Seat (A) to the Back (C) with 2 bolts (I) & 2 Spring Washers (J) by using the Allen Wrench (N).

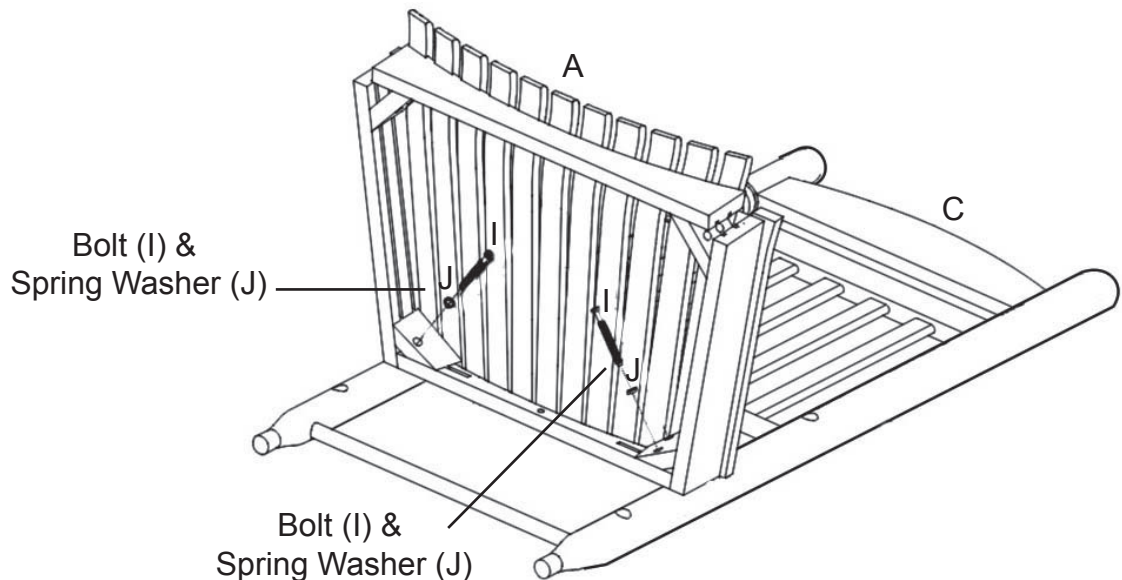

**Step 2:**

Put the 2 Rails (D) & the Front Frame (B) to the corresponding place, connect 2 Rails (D) & the Front Frame (B) with 4 Screws (L) then tighten with 2 Bolts (I) and 2 Spring Washers (J) by using the Allen Wrench (N).

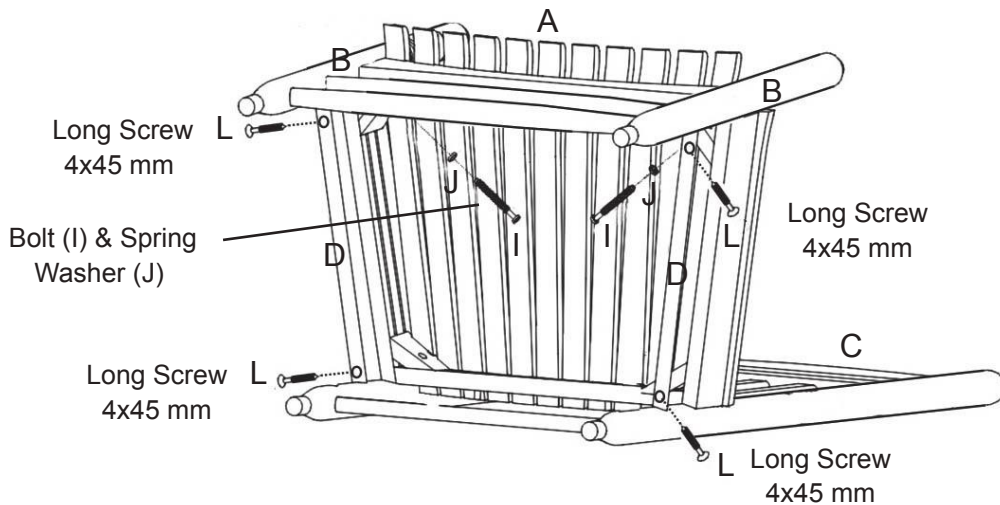

**Step 3:**

1. Attach the Left & Right Arms (E, F) as pictured below. With a screwdriver, tighten the arms to the Back (C) with 2 Hexagon Heads (M) & to the Front Frame (B) with 2 Long Screws (L).
2. Attach the Runners (G) to the Back (C) & to the Front Frame (B) with 4 Long Screws (L) and a screwdriver.

