

# Dyna-Glo®

## 5-BURNER LP GAS GRILL WITH SIDE BURNER

Model #DGF510SBP

Français p. 31

Español p. 61

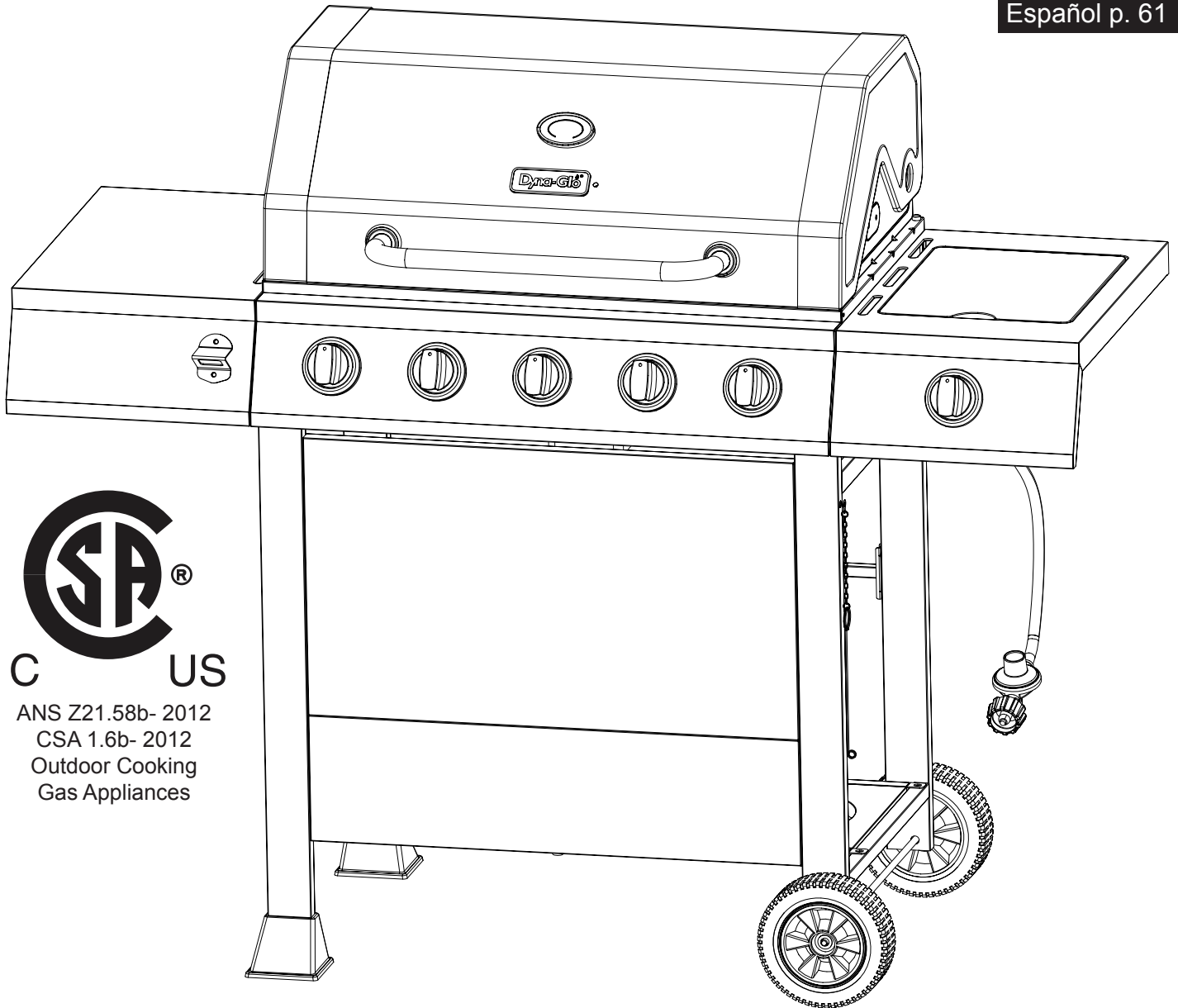

C US

ANS Z21.58b- 2012  
CSA 1.6b- 2012  
Outdoor Cooking  
Gas Appliances

**ATTACH YOUR RECEIPT HERE**

Serial Number \_\_\_\_\_ Purchase Date \_\_\_\_\_



**Questions, problems, missing parts?** Before returning to your retailer, call our customer service department at 1-877-447-4768, 8:30 a.m. – 4:30 p.m., CST, Monday – Friday or e-mail us at [customerservice@ghpgroupinc.com](mailto:customerservice@ghpgroupinc.com).



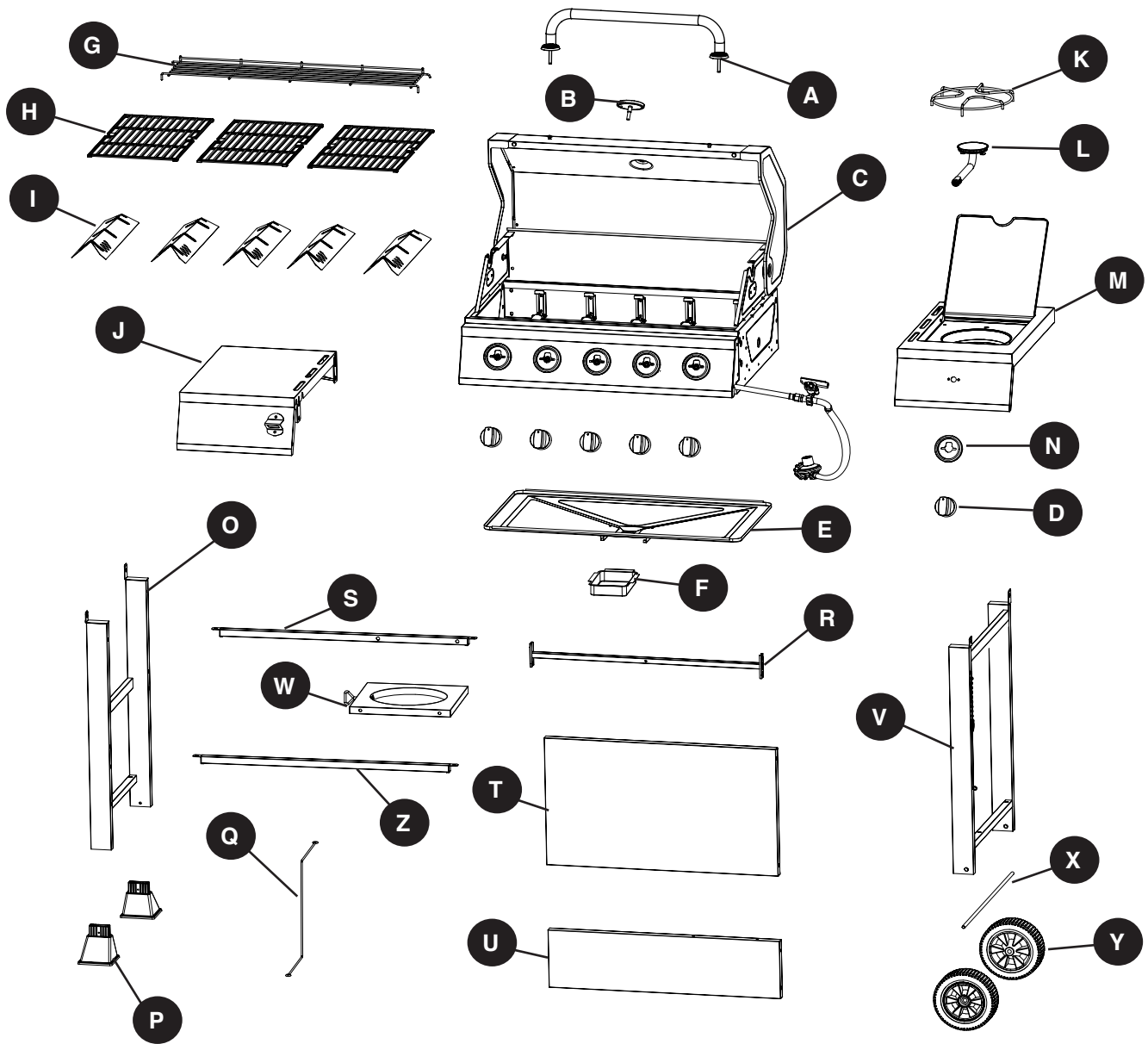





# PACKAGE CONTENTS

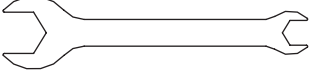

PART	DESCRIPTION	QUANTITY
A	Hood Handle	1
B	Temp Gauge	1
C	Grill Body Assembly	1
D	Control Knob	6
E	Grease Pan	1
F	Grease Cup	1
G	Warming Rack	1
H	Cooking Grate	3
I	Heat Tent	5
J	Left Side Table Assembly	1
K	Side Burner Rack	1
L	Side Burner	1
M	Right Side Burner Body	1
N	Control Knob Bezel	1

PART	DESCRIPTION	QUANTITY
O	Left Leg Assembly	1
P	Leg End Cap	2
Q	Cylinder Block Bar	1
R	Cart Rear Support	1
S	Bottom Shelf's Rear Bracket Assembly	1
T	Cart Front Panel - Upper	1
U	Cart Front Panel - Lower	1
V	Right Leg Assembly	1
W	Bottom Shelf	1
X	Axle	1
Y	Wheel	2
Z	Bottom Shelf's Front Bracket Assembly	1

## HARDWARE CONTENTS

AA	BB	CC	DD	EE	FF
					
ST4.8x10 Screw	M10 Nut	M10-M6 Wrench	M6x16 Bolt	M5x12 Bolt	M6 Wingnut
Qty. 2	Qty. 2	Qty. 2	Qty. 34	Qty. 2	Qty. 2
GG	HH	II			
					
M6 Spring Washer	M6 Washer	M4x10 Bolt			
Qty. 2	Qty. 2	Qty. 2			

## PREPARATION

Before beginning assembly of product, make sure all parts are present. Compare parts with package contents list on previous page and hardware contents above. If any part is missing or damaged, do not attempt to assemble the product. Contact customer service for replacement parts.

**Estimated Assembly Time:** 50 minutes with 2 people.

**Tools Required for Assembly and Leak Testing (not included):** Phillips screwdriver, Spray bottle, Plier, Adjustable Wrench

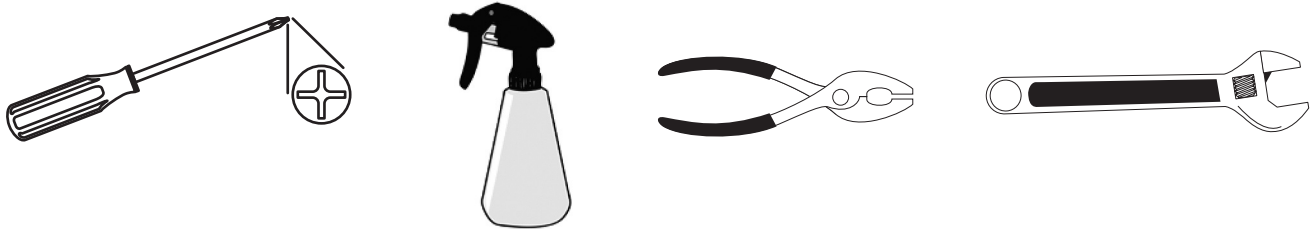

## ⚠ CAUTION

**THIS UNIT IS HEAVY. Two people required for safe assembly.**

Two people required for safe assembly. Some parts may contain sharp edges. Wear protective gloves if necessary. Read and follow all safety statements, warnings, assembly instructions and use and care instructions before attempting to assemble and use.

## ASSEMBLY INSTRUCTIONS

1. Put two leg end caps (P) under left leg assembly (O), and fasten them with two ST4.8X10 screws (AA).

### Hardware Used

**AA** ST4.8x10 Screw  x 2

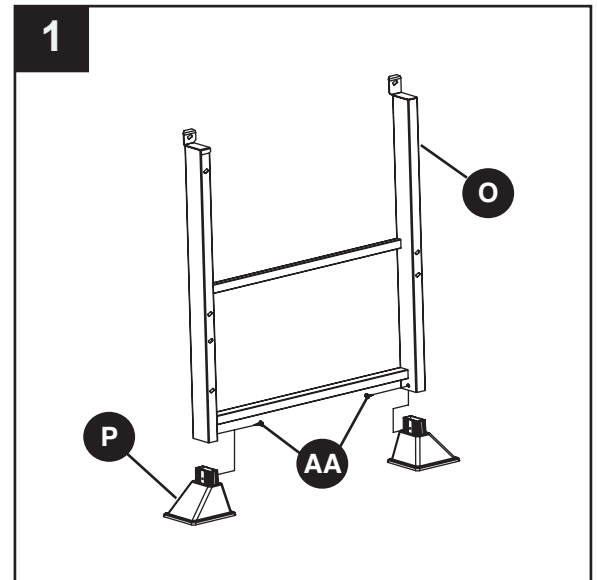

2. Slide the axle (X) through the right leg assembly (V) and then put the wheels (Y) on both sides, and tighten the wheels with M10 nuts (BB) with wrenches (CC). Please note, this step requires two people to complete, and if necessary any other plier or adjustable wrench can be used for assembly.

### Hardware Used

**BB** M10 Nut  x 2

**CC** M10-M6 Wrench  x 2

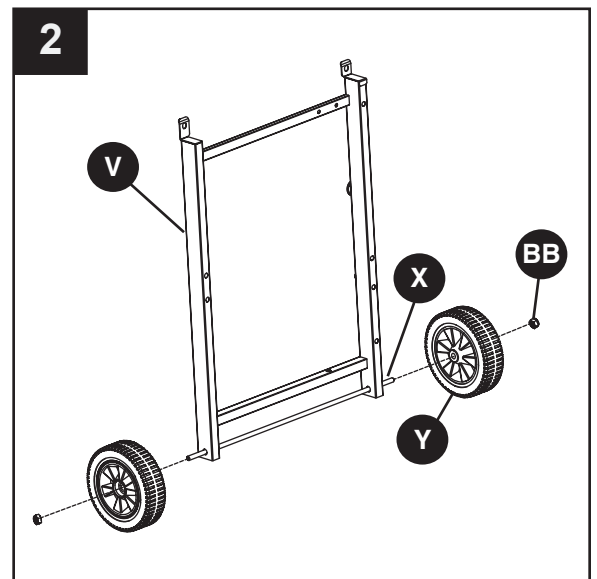

## ASSEMBLY INSTRUCTIONS

3. Use eight M6x16 bolts (DD) to assemble cart front panel - upper (T) and cart front panel - lower (U) between left leg assembly (O) and right leg assembly (V). Please note the front panel - lower's (U) direction, the side with rivet nut in the middle should be downward.

### Hardware Used

**DD** M6x16 Bolt  x 8

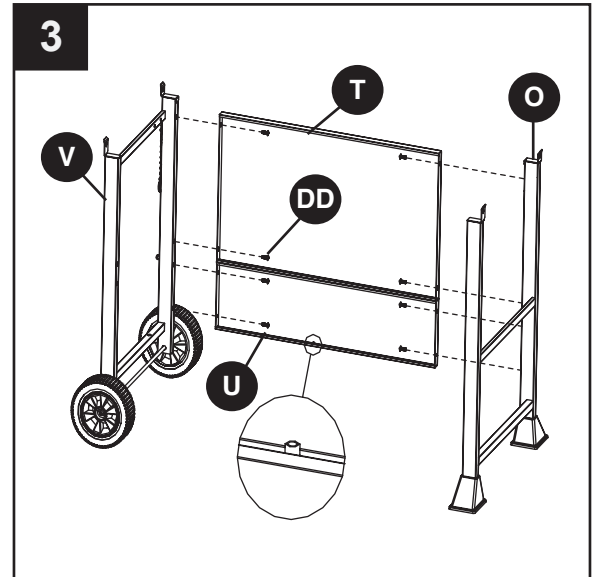

4. Use four M6X16 bolts (DD) to fasten the bottom shelf's front bracket assembly (Z), bottom shelf's rear bracket assembly (S) and bottom shelf (W).

### Hardware Used

**DD** M6x16 Bolt  x 4

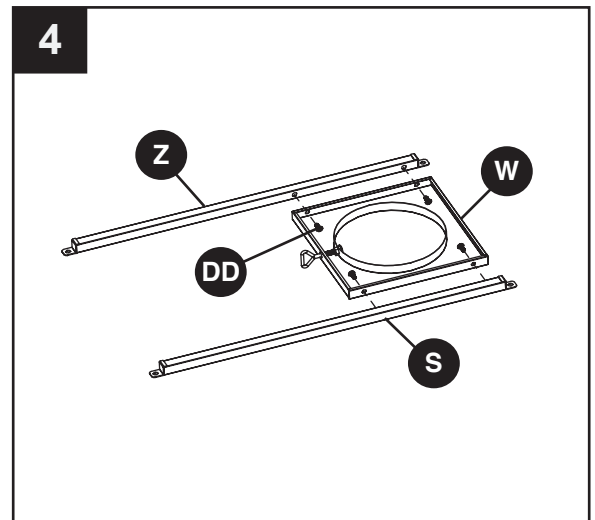

## ASSEMBLY INSTRUCTIONS

5. Assemble bottom shelf assembly to the left leg assembly (V) and right leg assembly (V) with four M6X16 bolts (DD).

### Hardware Used

**DD** M6x16 Bolt  x 4

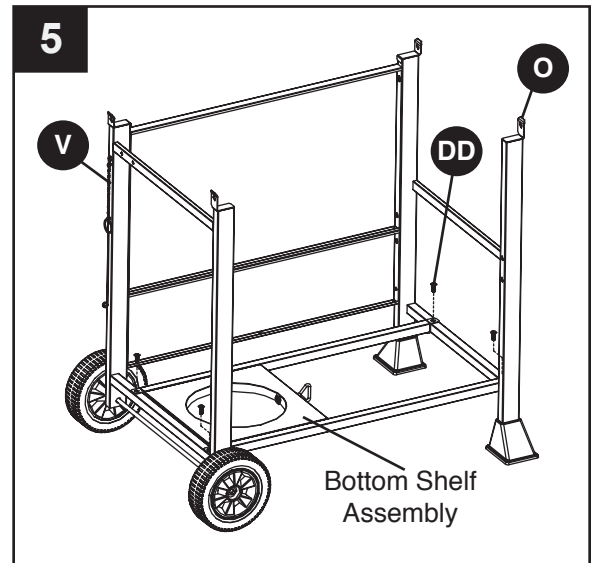

6. Use four M6x16 bolts (DD) to fasten the cart rear support (R) to the left and right leg assembly. Please note the cart rear support's (R) direction, the side with the rivet nut in the middle should be upward. Then use two M5x12 bolts (EE) to fasten the cylinder block bar (Q) between the cart front panel - lower (U) and the cart rear support (R).

### Hardware Used

**DD** M6x16 Bolt  x 4

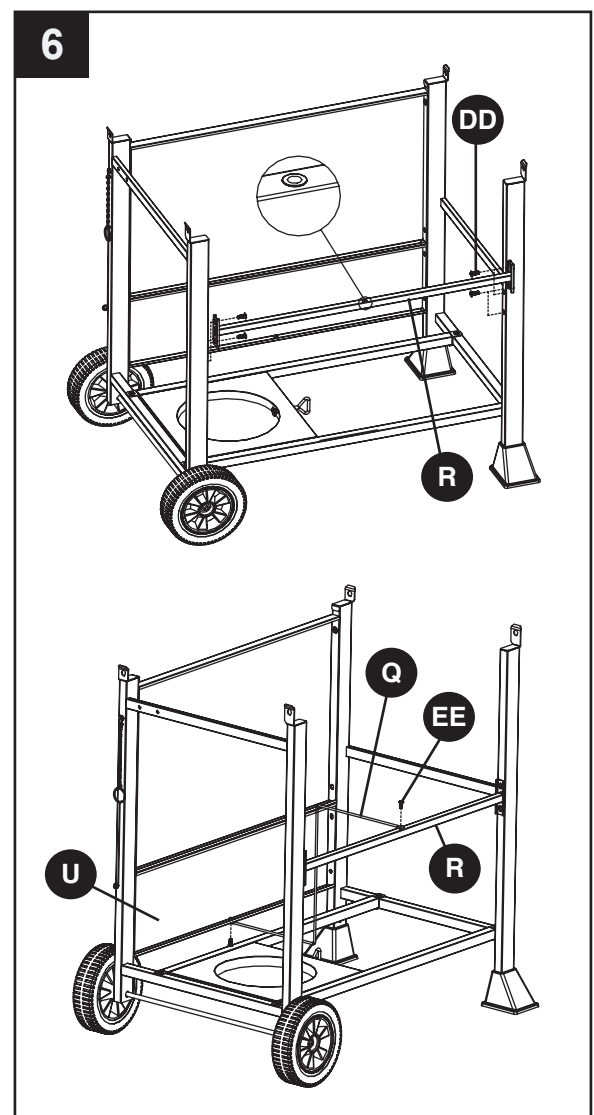

**EE** M5x12 Bolt  x 2



## ASSEMBLY INSTRUCTIONS

7. Assemble the hood handle (A) to the hood with two wingnuts (FF) and two spring washers (GG) and two M6 washers (HH).

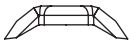
### Hardware Used

<b>FF</b>	M6 Wingnut		x 2
<b>GG</b>	M6 Spring Washer		x 2
<b>HH</b>	M6 Washer		x 2

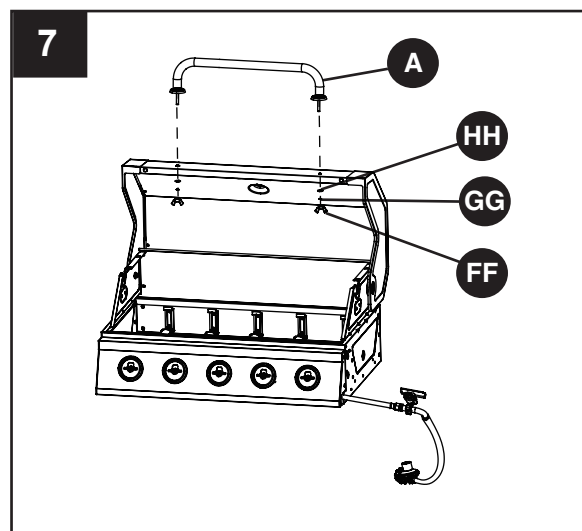

8. Assemble the temp gauge (B) onto the hood. Please use the washer and wing nut pre-assembled with temp gauge to install the temp gauge (B) onto the hood.

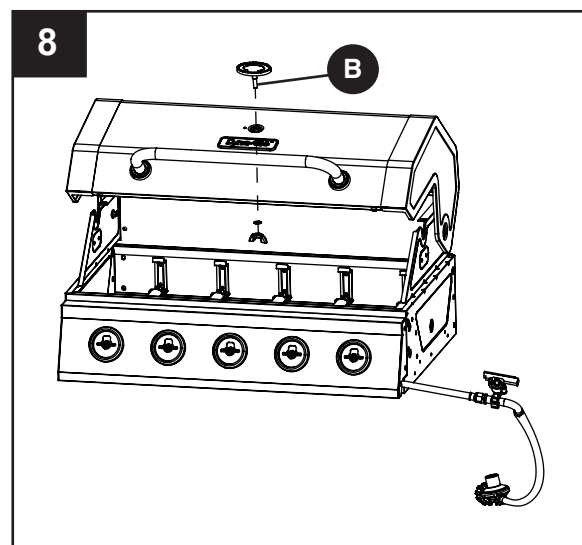

## ASSEMBLY INSTRUCTIONS

9. Assemble the grill body assembly (C) onto the cart assembly with four M6x16 bolts (DD).

### Hardware Used

**DD** M6x16 Bolt  x 4

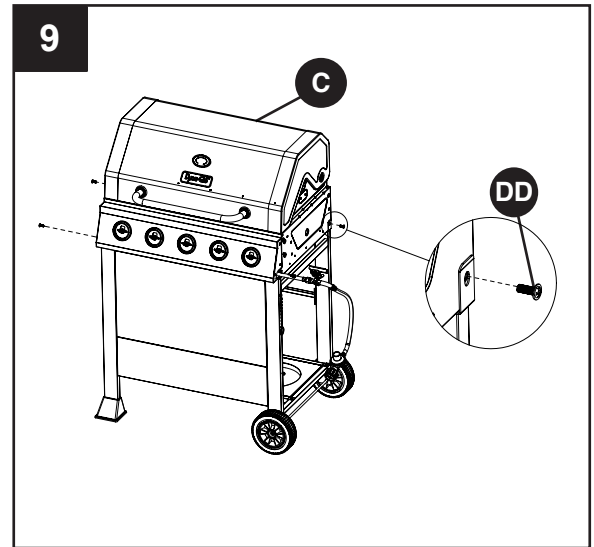

10. Pre-assemble two M6x16 bolts (DD) onto the grill body assembly (C) and do not tighten them and make sure to leave a 5mm gap between the bolt and grill body's end cap. Then hang the left side table assembly (J) on the bolts and fasten the left side table assembly (J) with three M6x16 bolts (DD) and tighten all bolts.

### Hardware Used

**DD** M6x16 Bolt  x 5

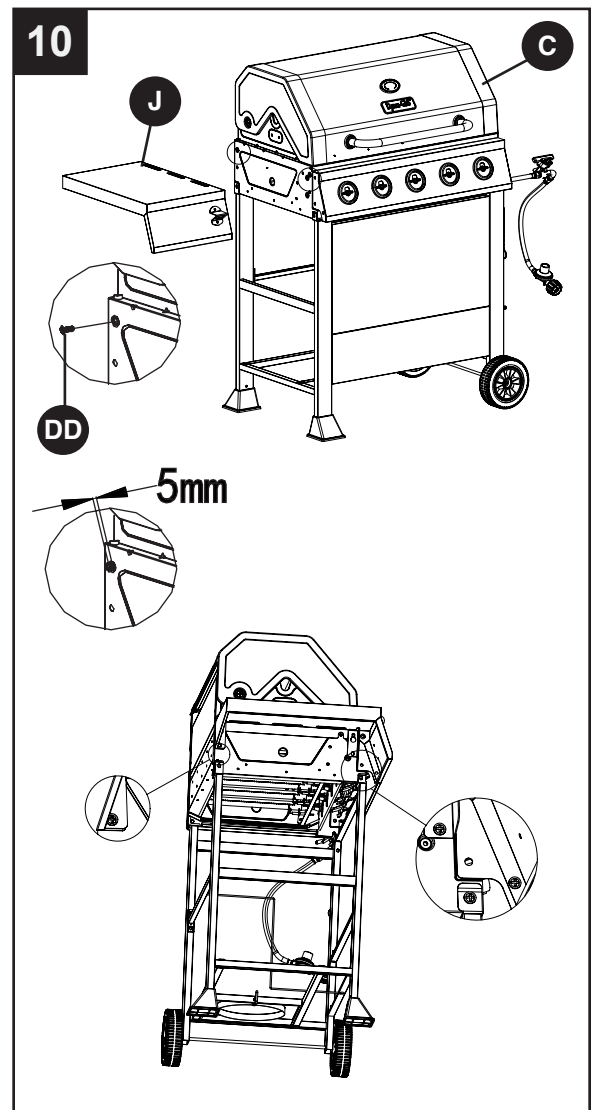



## ASSEMBLY INSTRUCTIONS

11. Pre-assemble two M6x16 bolts (DD) onto the grill body assembly (C) and do not tighten them and make sure to leave a 5mm gap between the bolt and grill body's end cap. Then hang the right side burner body (M) on the bolts and fasten the right side burner body (M) with three M6x16 bolts (DD) and tighten all bolts.

### Hardware Used

**DD** M6x16 Bolt  x 5

12. Use two M4x10 bolts (II) to assemble the side burner valve assembly and control knob bezel (N) to the right side burner body (M).

### Hardware Used

**II** M4x10 Bolt  x 2

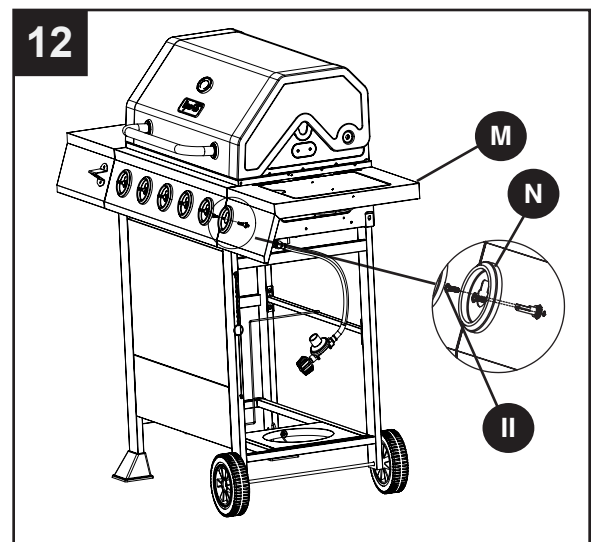
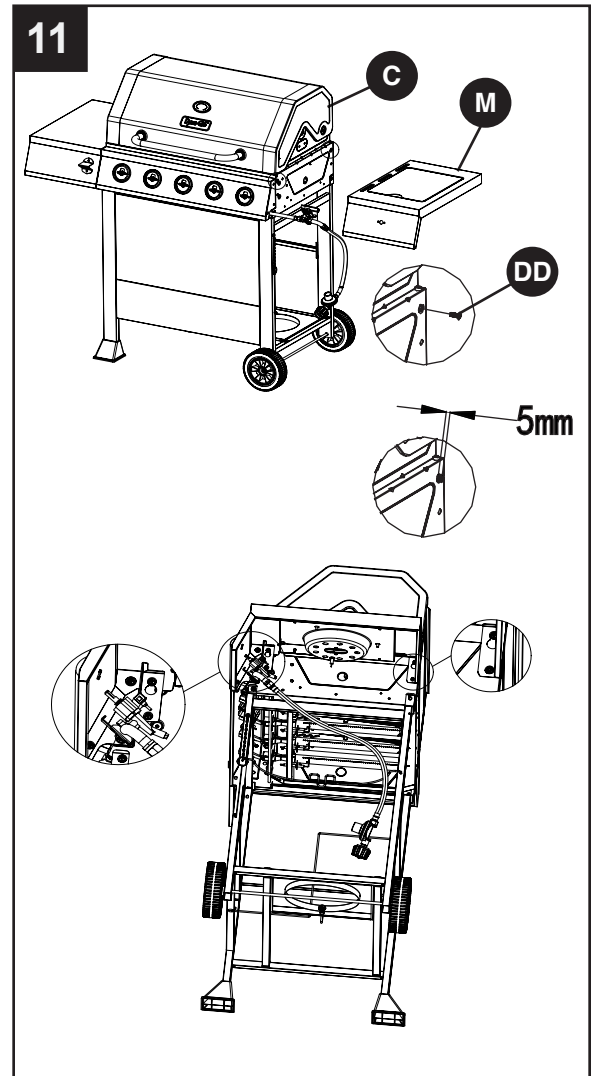

# ASSEMBLY INSTRUCTIONS

13. Disassemble two M4x10 bolts that are pre-assembled on the side burner (L) and use them to assemble the side burner (L) on the right side burner body (M). Please ensure the gas valve orifice is correctly positioned inside side burner inlet (venturi).

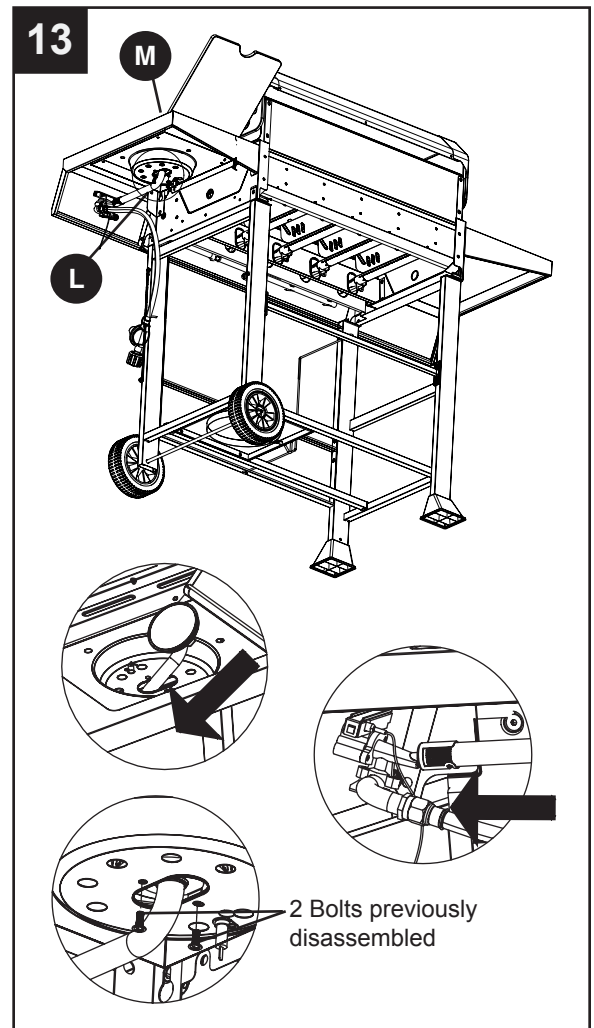
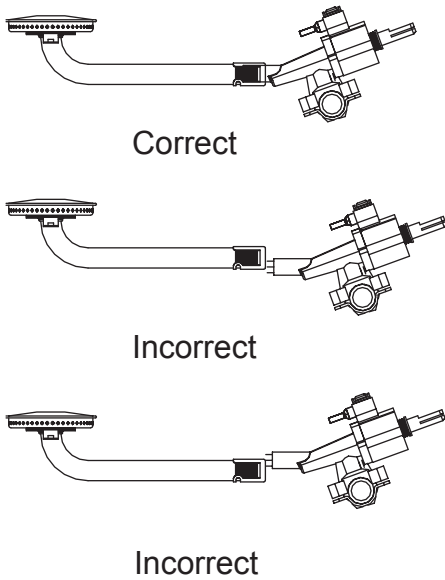

14. Connect the side burner sparker wire to the side burner sparker.

**⚠ WARNING: IT IS VERY IMPORTANT TO CHECK AND ENSURE THAT EACH AND EVERY BURNER IS FULLY ENGAGED WITH THE ADJACENT VALVE ORIFICE BEFORE COMPLETING STEP 15. FAILURE TO DO SO MAY RESULT IN FIRE OR EXPLOSION, POSSIBLY CAUSING SERIOUS INJURY OR DEATH. REFER TO MAINTENANCE SECTION INSTRUCTIONS TO PROPERLY CHECK THE ENGAGEMENT.**

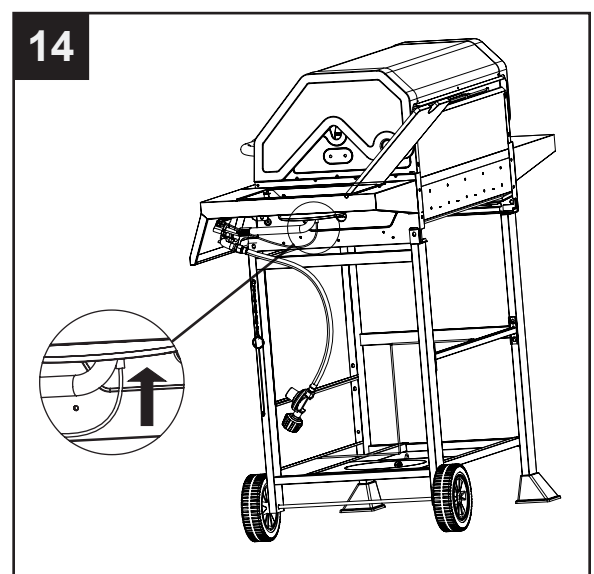
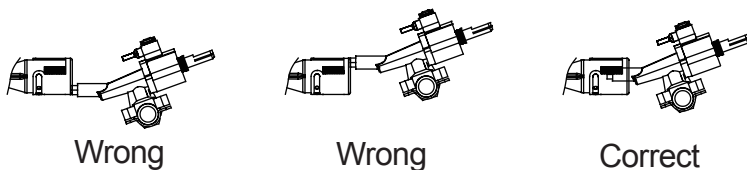

## ASSEMBLY INSTRUCTIONS

15. Put the side burner rack (K) in place.

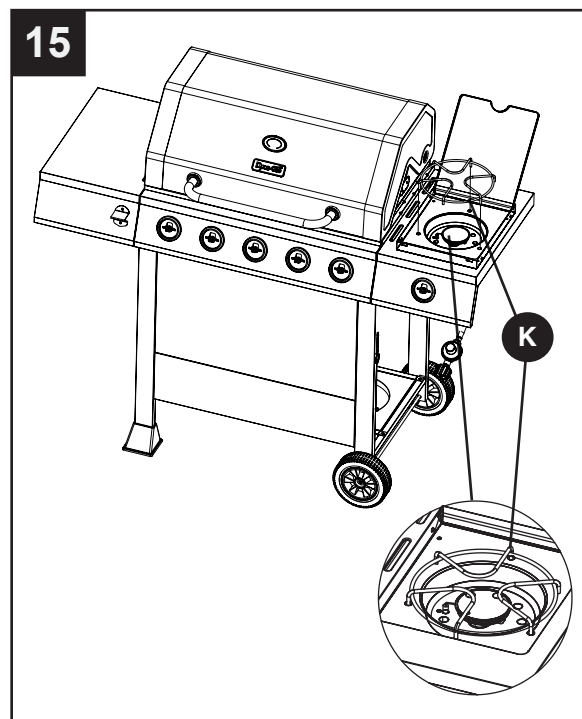

16. Assemble the six control knobs (D).

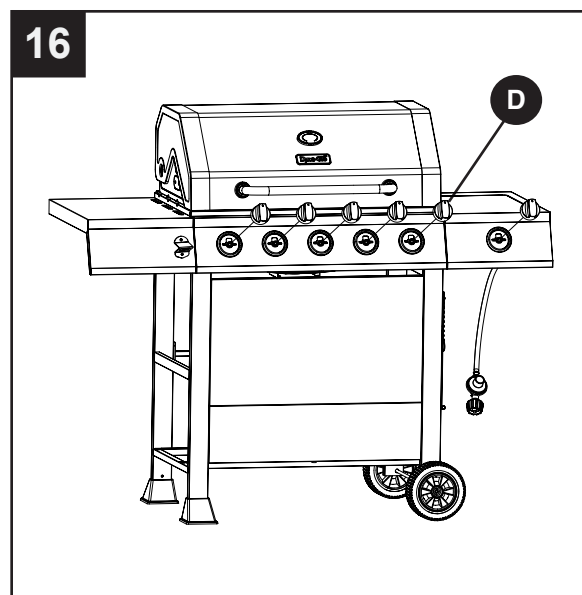

## ASSEMBLY INSTRUCTIONS

17. Put the five heat tents (I) into place over each burner.

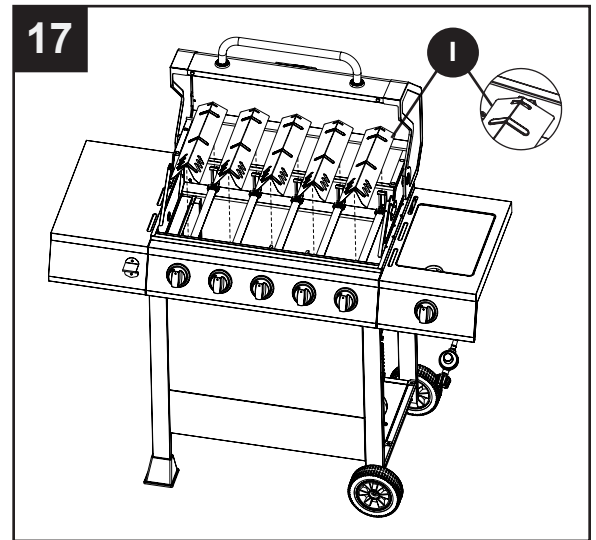

18. Put three cooking grates (H) and one warming rack (G) in place.

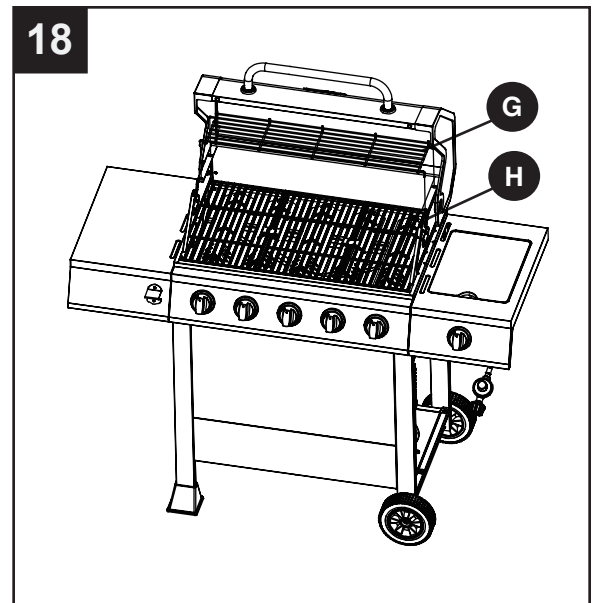

## ASSEMBLY INSTRUCTIONS

19. Place grease pan (E) and grease cup (F) in place.

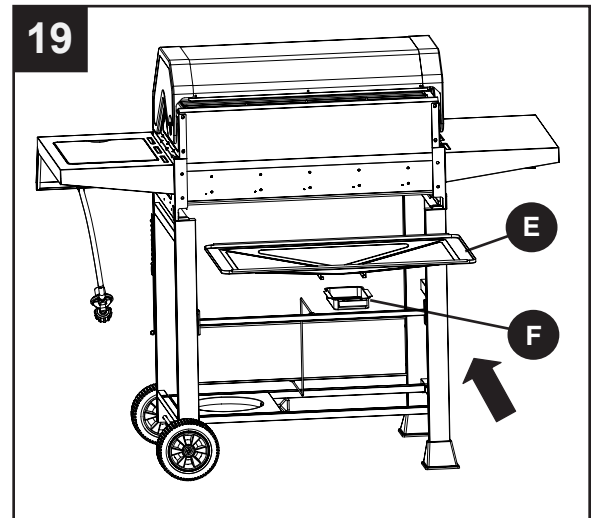

20. Place gas cylinder (sold separately) into the nesting hole located in the Bottom shelf (W). Rotate the gas cylinder until the hose/regulator coupling aligns with the threaded valve of the cylinder. Hand-tighten the hose/regulator coupling to the threaded valve of the LP gas cylinder.

Tighten the tank screw clockwise  in the bottom shelf (W) until the cylinder is secured in place inside the nesting hole of the Bottom shelf (W).

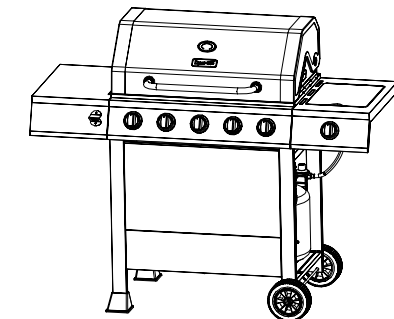

Front View

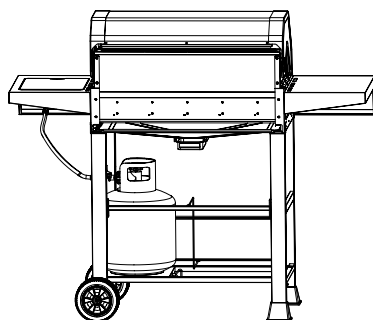

Rear View

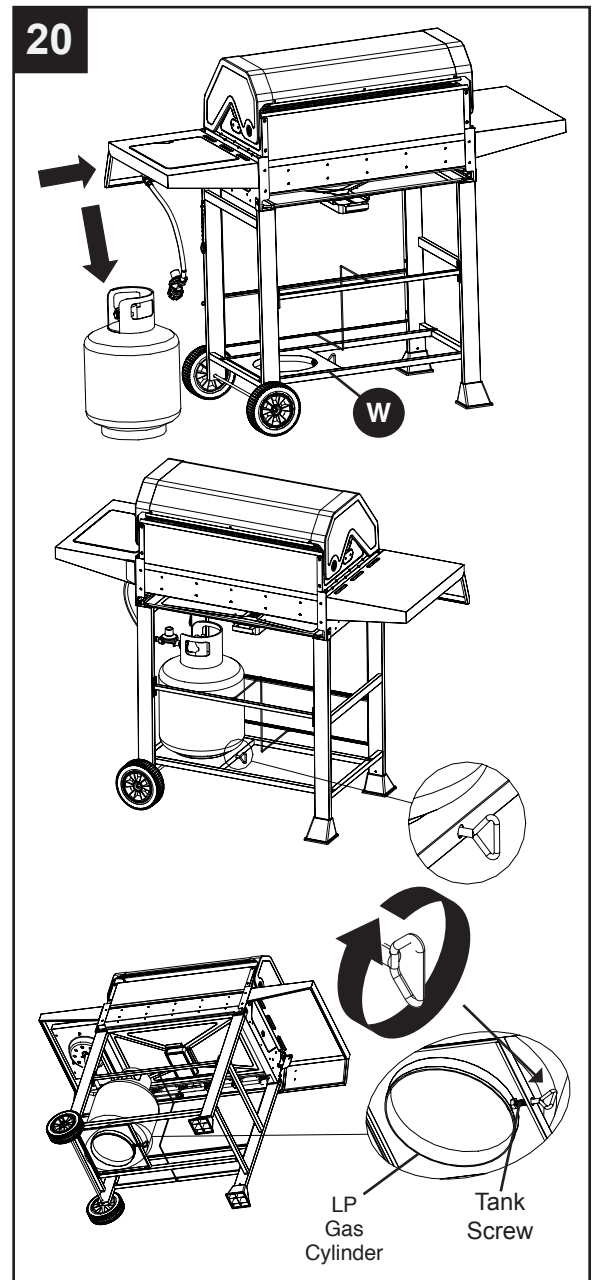

# Dyna-Glo®

## GRIL À 5 BRÛLEURS AVEC BRÛLEUR LATÉRAL À UTILISER AVEC DU PROPANE LIQUIDE

Modèle #DGF510SBP

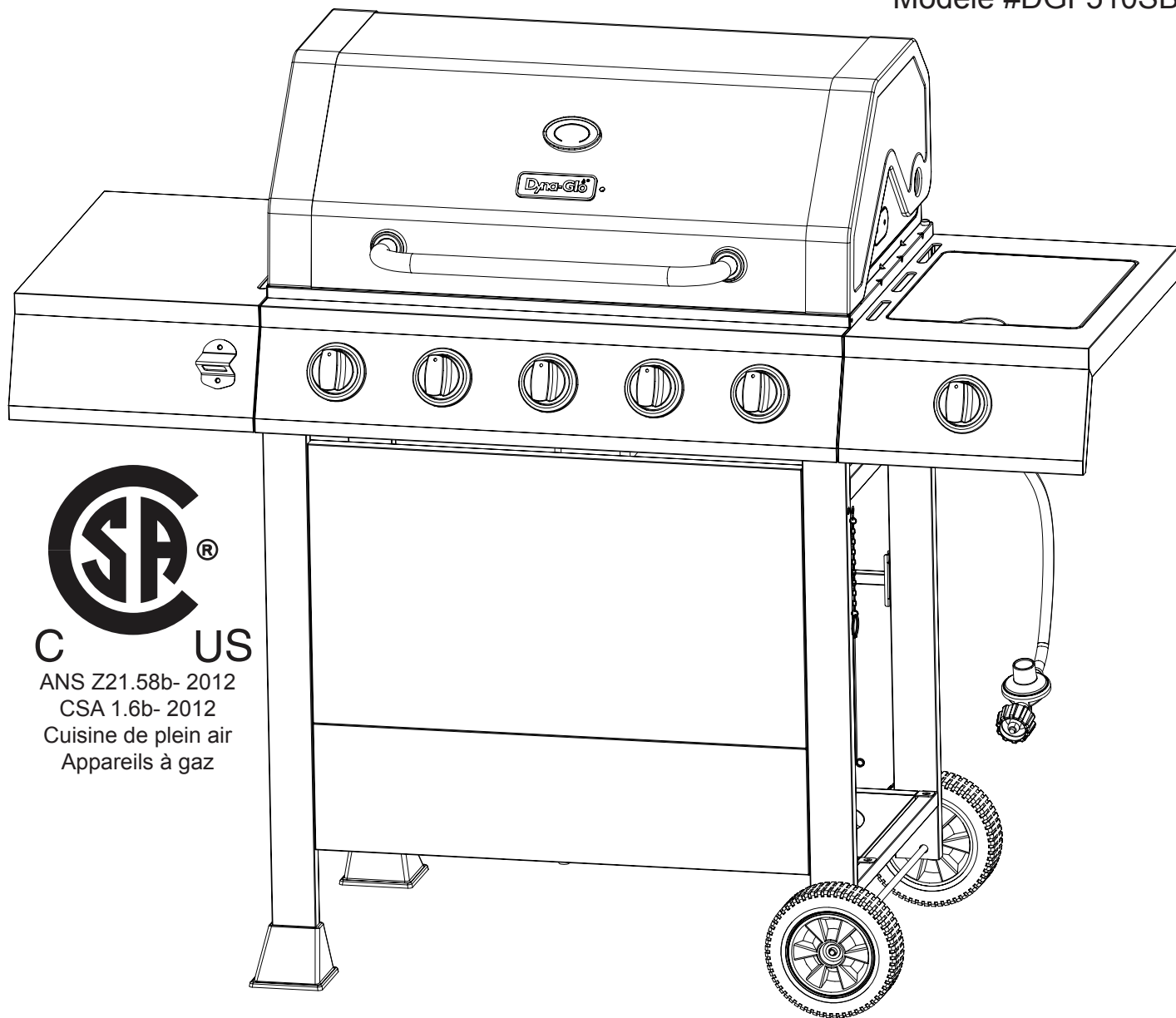

C US

ANS Z21.58b- 2012

CSA 1.6b- 2012

Cuisine de plein air

Appareils à gaz

**JOIGNEZ VOTRE REÇU ICI**

Numéro de série \_\_\_\_\_ Date d'achat \_\_\_\_\_



**Des questions, des problèmes, des pièces manquantes?** Avant de retourner l'article au détaillant, appelez notre service à la clientèle au 1-877-447-4768, 08:30-16 heures 30, HNC, du lundi - vendredi ou par e-mail à [customerservice@ghpgroupinc.com](mailto:customerservice@ghpgroupinc.com).



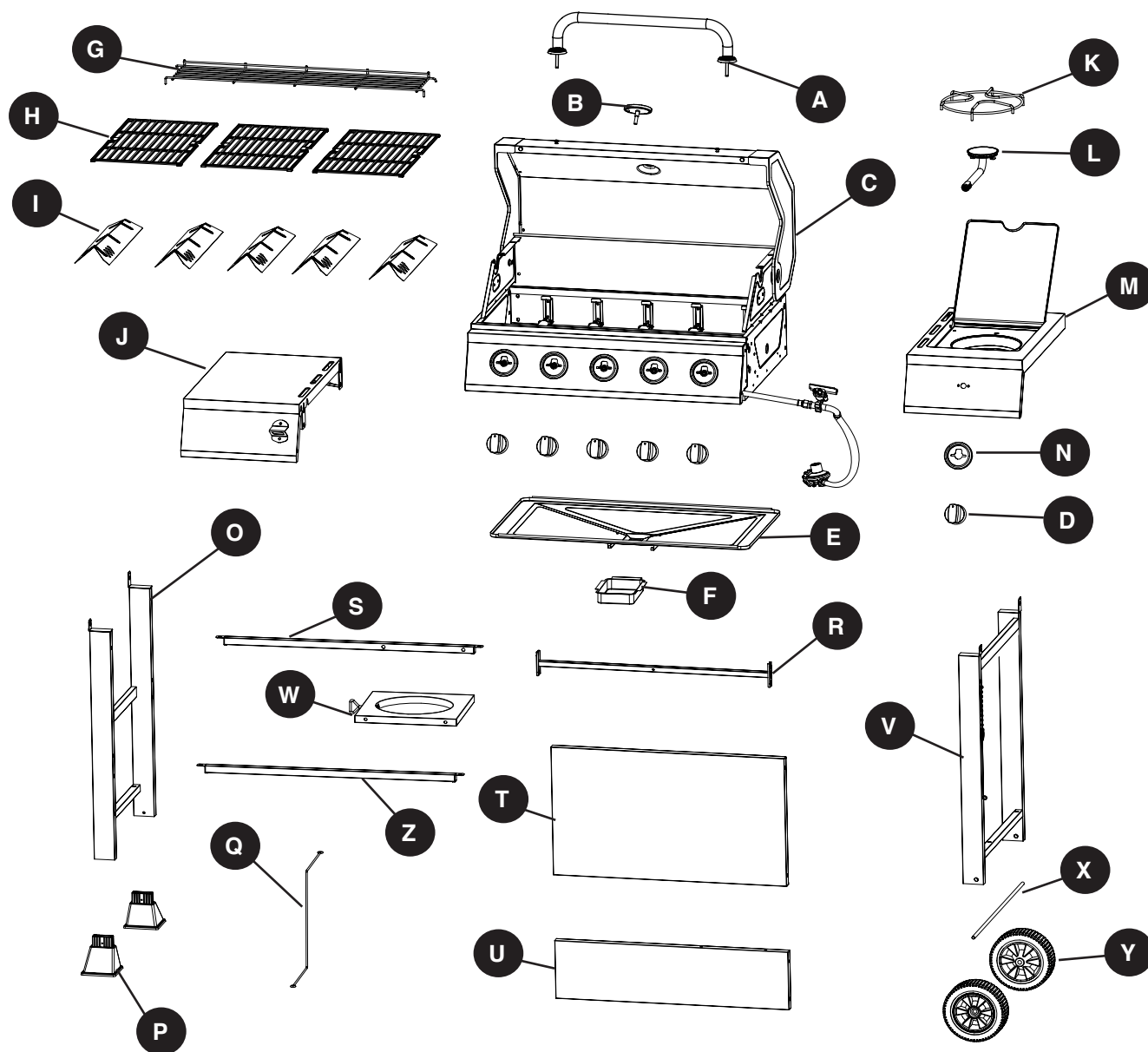





## CONTENU DE L'EMBALLAGE



PIÈCE	DESCRIPTION	QTÉ
A	Poignée au couvercle	1
B	Jauge à température	1
C	Structure du barbecue	1
D	Poignées de commande	6
E	Plateau à graisse	1
F	Godet collecteur	1
G	Plaque chauffante	1
H	Grille de cuisson	3
I	Plaques de chaleurs	5
J	Côté gauche la table d'assemblage	1
K	Planche de brûleur	1
L	Brûleur latéral	1
M	Corps du brûleur latéral droit	1
N	Poignées de commande lunette	1

PIÈCE	DESCRIPTION	QTÉ
O	Patte gauche d'assemblage	1
P	Embouts	2
Q	Barre bloc-cylindres	1
R	Support d'assemblage du chariot	1
S	Planche basse du support arrière d'assemblage	1
T	Panneau avant supérieur du chariot	1
U	Panneau avant inférieur du chariot	1
V	Patte droite d'assemblage	1
W	Planche basse	1
X	Roues	1
Y	Fil du cylindre de rétention	2
Z	Planche basse du support avant d'assemblage	1

## QUINCAILLERIE INCLUSE (grandeur réelle)

					
ST4.8x10 Vis	M10 Écrou	M10-M6 Cle	M6x16 Boulon	M5x12 Boulon	M6 Écrous Papillon
Qte. 2	Qte. 2	Qte. 2	Qte. 34	Qte. 2	Qte. 2
					
M6 Rondelles de Blocage	M6 Rondelles	M4x10 Boulon			
Qte. 2	Qte. 2	Qte. 2			

## PRÉPARATION

Avant de commencer l'assemblage du produit, assurez-vous d'avoir toutes les pièces. Comparez les pièces dans l'emballage avec la liste des pièces de la page précédente et la quincaillerie indiquée ci-dessus. S'il y a des pièces manquantes ou endommagées, ne tentez pas d'assembler le produit. Communiquez avec le service à la clientèle pour obtenir des pièces de rechange.

**Temps d'assemblage approximatif** : 50 minutes, par deux personnes

**Outils nécessaires pour l'assemblage et la vérification des fuites (non inclus)** : tournevis cruciforme et vaporisateur, pince, clé à molette

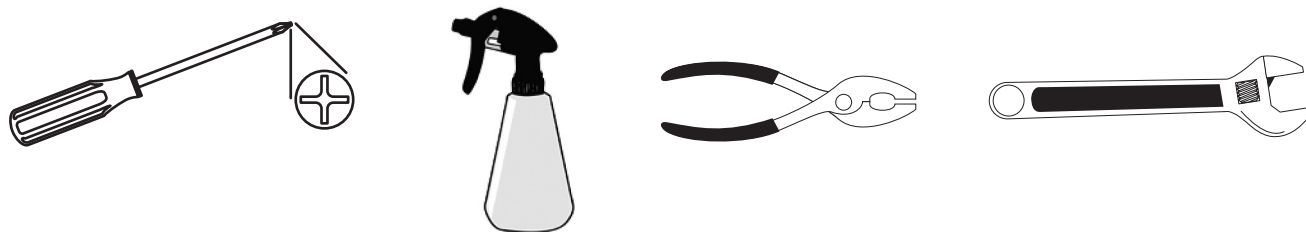

## ⚠ MISE EN GARDE

**CET ARTICLE EST LOURD. DEUX PERSONNES SONT NÉCESSAIRES POUR ASSEMBLER L'ARTICLE EN TOUTE SÉCURITÉ.**

Deux personnes sont nécessaires pour l'assembler en toute sécurité. Soyez prudent, car certaines pièces peuvent avoir des bords coupants. Au besoin, portez des gants protecteurs. Lisez et respectez tous les énoncés sur la sécurité et les avertissements, et suivez toutes les instructions pour l'assemblage ainsi que la section sur l'entretien de l'article avant de tenter d'assembler et d'utiliser cet article.



## INSTRUCTIONS POUR L'ASSEMBLAGE

1. Mettre les deux embouts (P) en dessous de la patte gauche d'assemblage (O), et puis fixer les avec les deux vis ST4.8X10 (AA).

### Quincaillerie utilisée

<b>AA</b>	ST4.8x10 Vis		x 2
-----------	--------------	---	-----

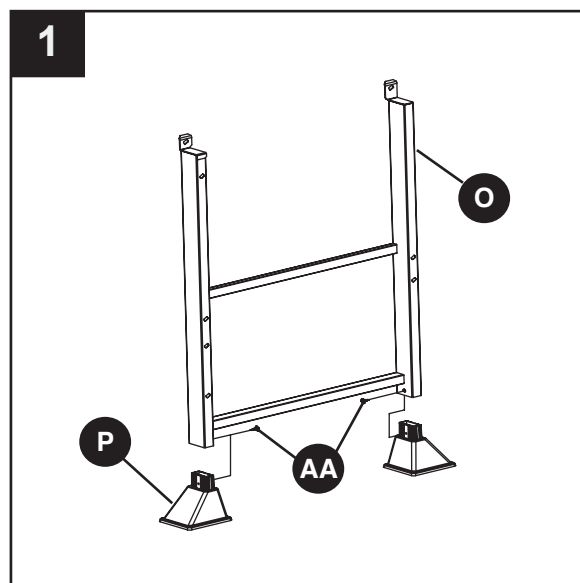

2. Glisser l'essieu (X) entre la patte droite d'assemblage (V) et puis, mettez les roues (Y) sur les deux côtés, et ensuite resserrer les roues avec l'écrou M10 (BB) et à l'aide de la clé à molette (CC). À noter, cette étape aura besoin de deux personnes être compléter, et si nécessaire d'autres pièces comme une pince ou une clé à molette ajustable peuvent aussi être utilisé pour l'assemblage.

### Quincaillerie utilisée

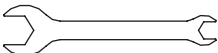
<b>BB</b>	M10 Ecrou		x 2
<b>CC</b>	M10-M6 Cle		x 2

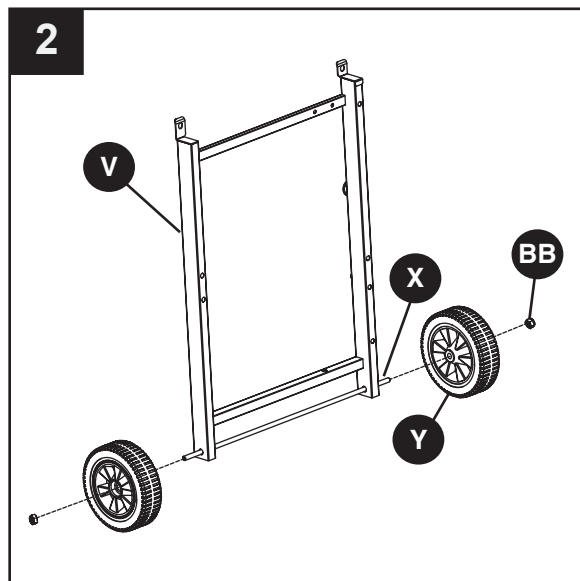

## INSTRUCTIONS POUR L'ASSEMBLAGE

3. Utiliser le boulons M6x16 (DD) pour assembler le panneau avant supérieur du chariot (T), et le panneau avant inférieur du chariot (U) entre la patte gauche d'assemblage (O) et la patte droite d'assemblage (V). À noter que la direction du panneau avant inférieur du chariot (U), le côté avec l'écrou rivet au centre, devrait être vers le bas.

### Quincaillerie utilisée

**DD** M6x16 Boulon  x 8

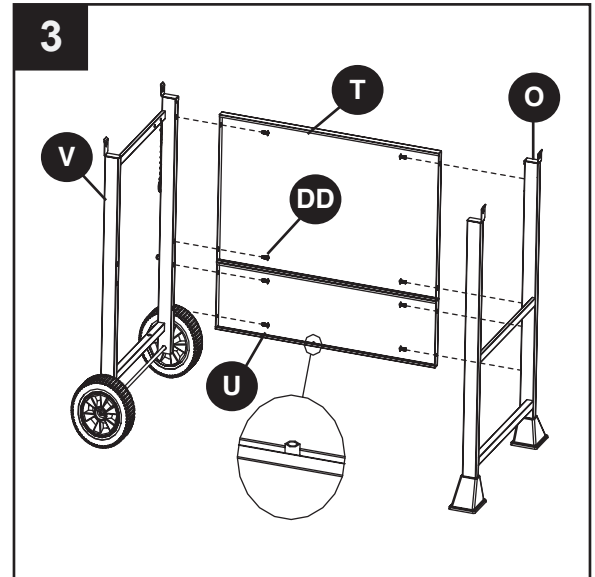

4. Utiliser quatre boulons M6x16 (DD) pour attacher la planche basse du support avant d'assemblage (S), le planche basse du support arrière d'assemblage (Z) et la planche basse (W).

### Quincaillerie utilisée

**DD** M6x16 Boulon  x 4

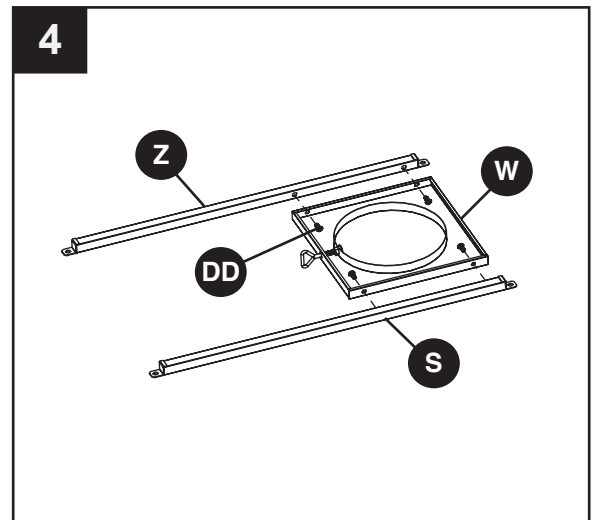

## INSTRUCTIONS POUR L'ASSEMBLAGE

5. Assembler la planche basse d'assemblage à la patte gauche d'assemblage (V) et à la patte droite d'assemblage (O) avec les quatre boulons M6x16 (DD).

### Quincaillerie utilisée

**DD** M6x16 Boulon  x 4

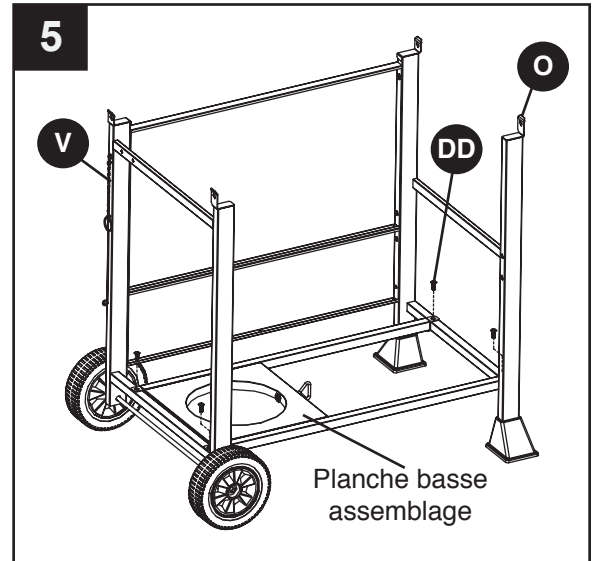

6. Utiliser quatre boulons M6x16 boulons (DD) pour attacher le support arrière du chariot (R) aux pattes gauche et droite d'assemblage, veuillez noter de la direction du support arrière du chariot (R), et que le côté ayant le rivet creux au milieu devrait se trouver vers le haut. Ensuite utiliser deux boulons M5x12 (EE) pour fixer la barre block cylindrique (Q) entre le panneau avant bas (U) et le support arrière du chariot (R).

### Quincaillerie utilisée

**DD** M6x16 Boulon  x 4

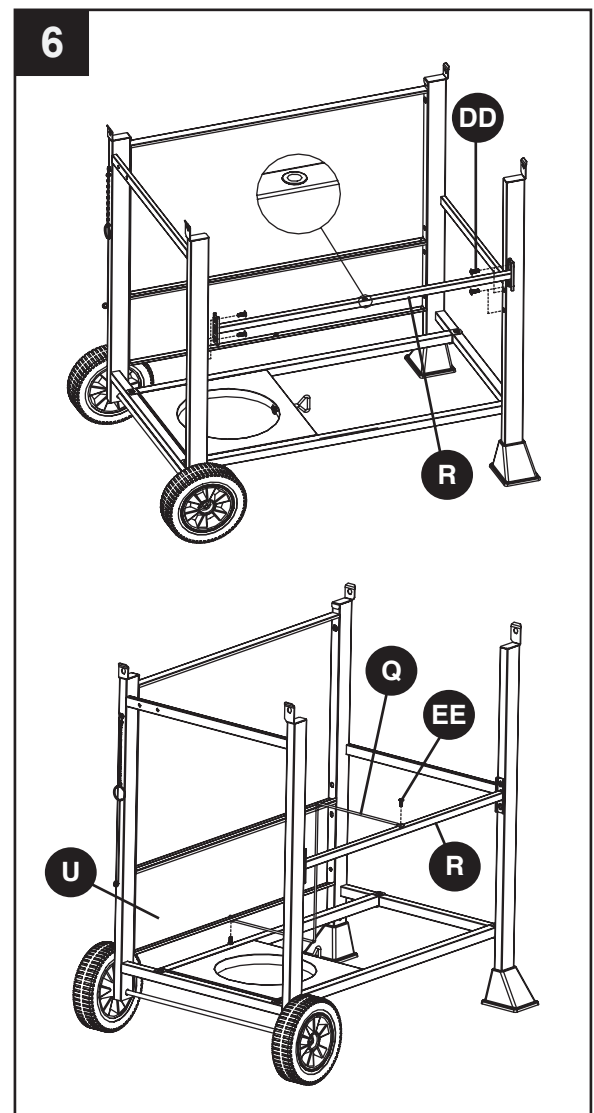

**EE** M5x12 Boulon  x 2



## INSTRUCTIONS POUR L'ASSEMBLAGE

7. Monter la pièce d'assemblage de la poignée au couvercle de barbecue (A) avec deux écrous papillon (FF), deux rondelles de blocage (GG) et deux rondelles M6 (HH).

### Quincaillerie utilisée

<b>FF</b>	M6 Écrous Papillon		x 2
<b>GG</b>	M6 Rondelles de Blocage		x 2
<b>HH</b>	M6 Rondelle		x 2

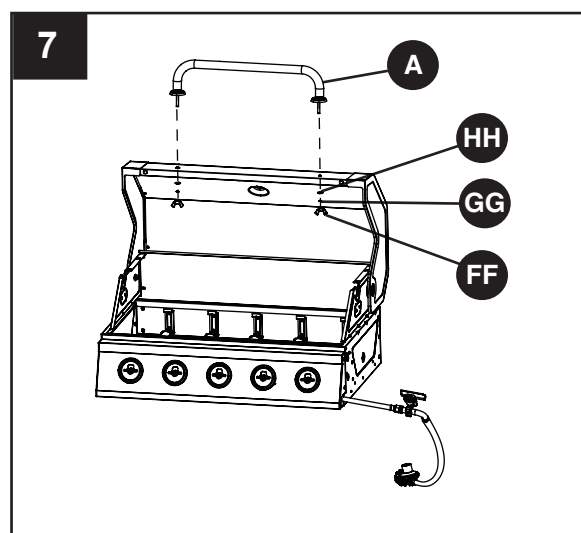

8. Monter la jauge à température (B) sur le couvercle de barbecue. S'il-vous-plaît utiliser la rondelle et écrou à ailettes pré-assemblé avec jauge à température (B) sur le capot.

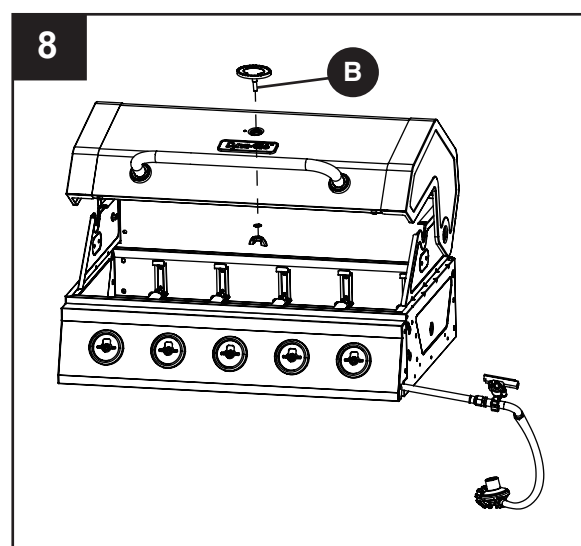

## INSTRUCTIONS POUR L'ASSEMBLAGE

9. Monter la pièce d'assemblage de la structure du barbecue sur la pièce d'assemblage (C) du chariot avec quatre boulons M6x6 (DD).

### Quincaillerie utilisée

**DD** M6x16 Boulon  x 4

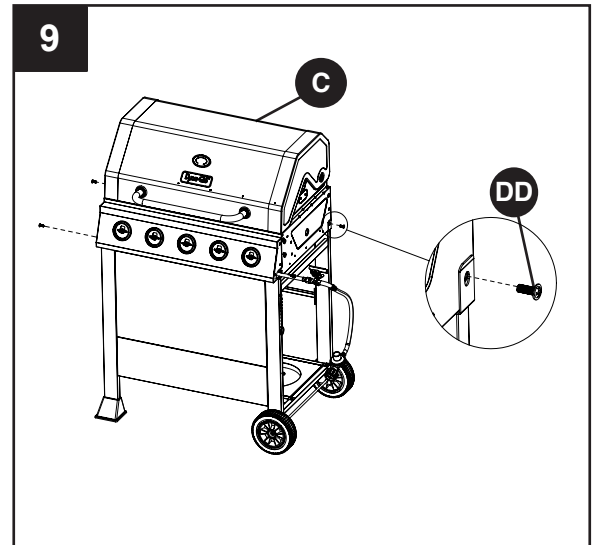

10. Monter d'avance deux boulons M6x16 (DD) sur la structure du barbecue (C) et ensuite de ne pas les resserrer et puis de s'assurer de laisser une ouverture de 5mm entre le boulon et l'embout de la structure du barbecue. Ensuite laisser pendre le côté gauche de la table d'assemblage (J) sur les boulons et fixer le côté gauche de la table d'assemblage (J) avec trois boulons M6x16(DD) et puis resserrer tous les boulons.

### Quincaillerie utilisée

**DD** M6x16 Boulon  x 5

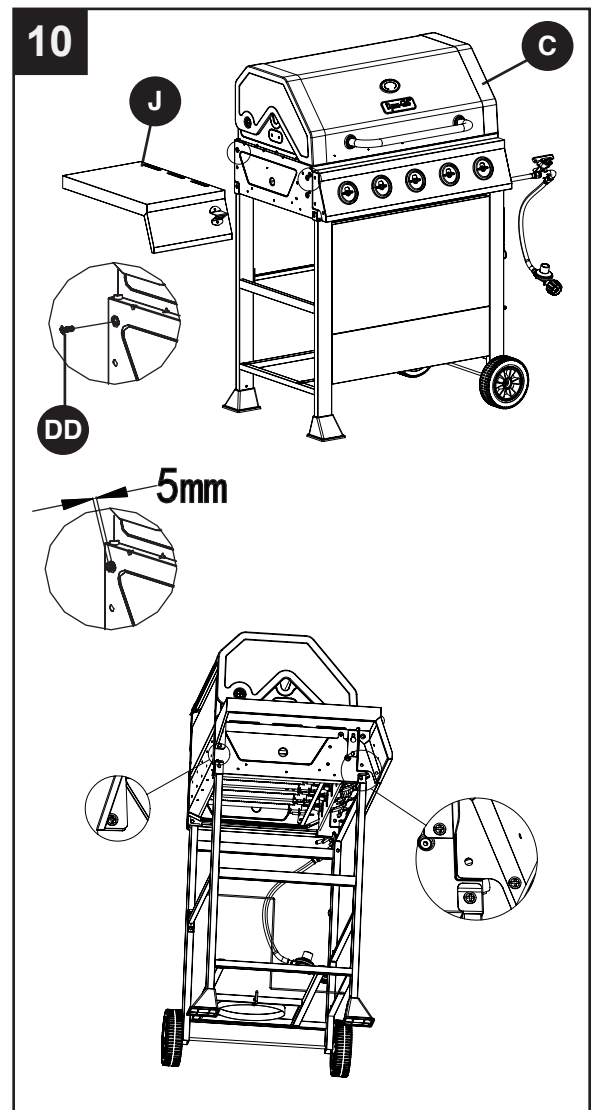

## INSTRUCTIONS POUR L'ASSEMBLAGE

13. Insérez two vis M6x16 (DD) dans le côté droit du boîtier du barbecue (C), mais le filetage des vis doit laisser un espace de 5mm, comme illustré. Alignez les trous du table brûleur latéral droite (M) aux 2 vis que vous venez d'insérer dans le boîtier du barbecue (C). Insérez three vis M6x16 (DD) dans les autres trous du boîtier du barbecue (C). Ajustez la table brûleur latéral droite (M) et serrez toutes les vis.

### Quincaillerie utilisée

**DD** M6x16 Boulon  x 5

12. Utiliser deux boulons M4x10 (II) pour assembler la pièce d'assemblage de côté pour la valve du brûleur à gaz et le chaton (N) du bouton de contrôle au côté droit du corps du brûleur (M).

### Quincaillerie utilisée

**II** M4x10 Boulon  x 2

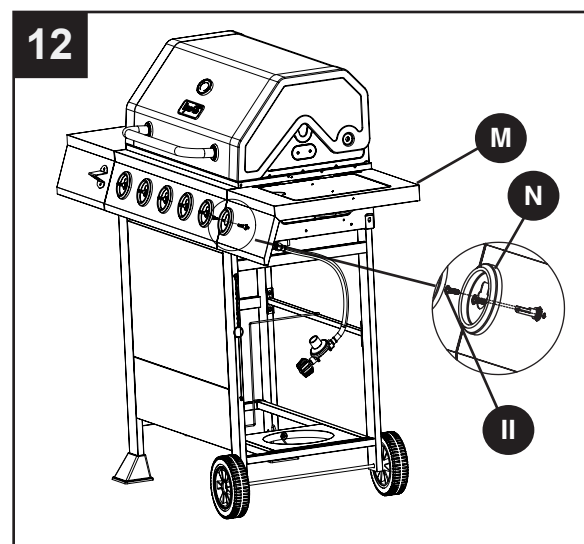
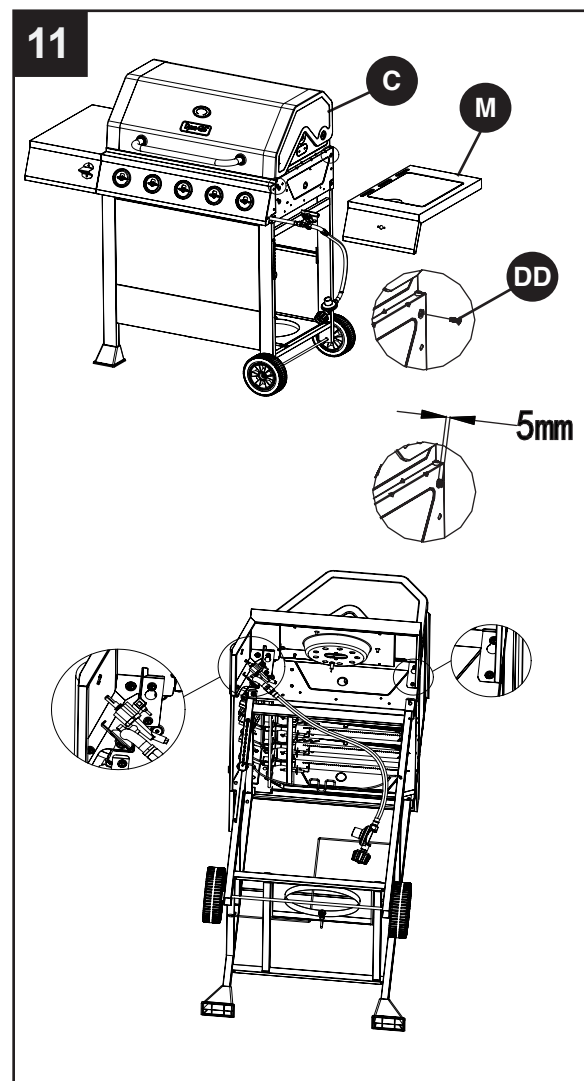

## INSTRUCTIONS POUR L'ASSEMBLAGE

13. Démontez deux boulons M4x10 étant déjà monté au brûleur de côté (L) et ensuite de les utiliser pour monter le brûleur de côté (L) au corps du brûleur (M). S'il vous plaît assurer vous que l'orifice de la soupape à gaz soit correctement positionné à l'intérieur de l'orifice du brûleur de côté.

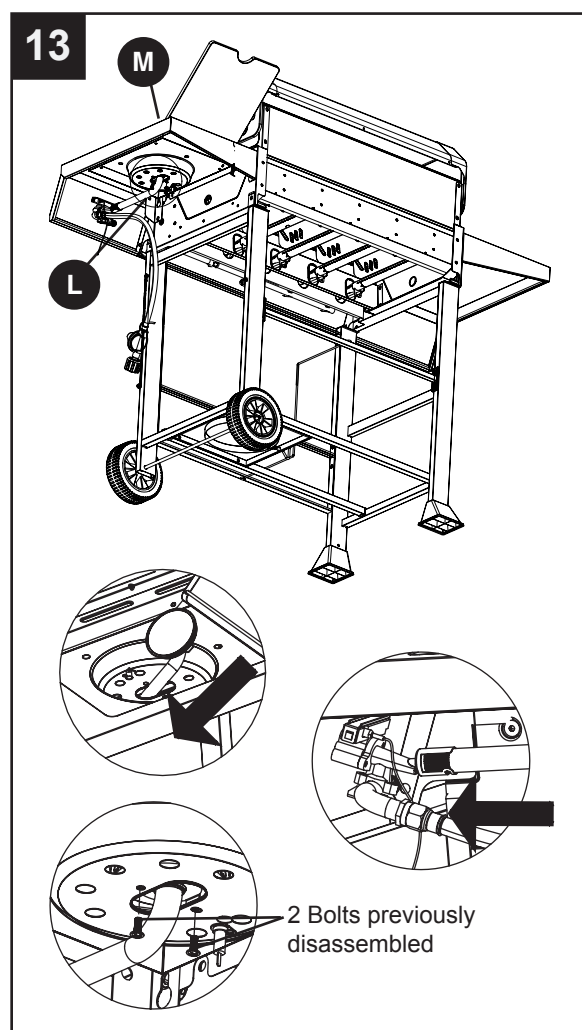
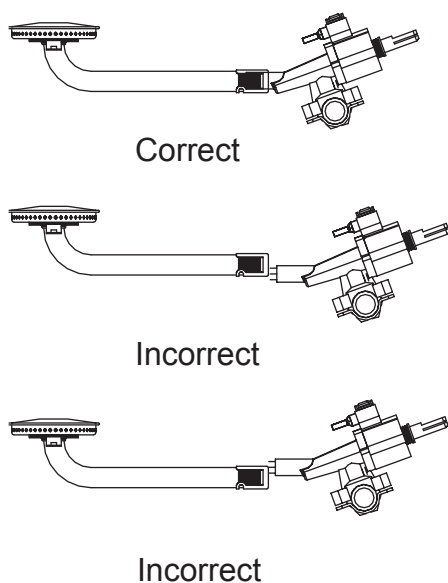

14. Relier le fils d'allumage du brûleur de côté au brûleur de côté.

**⚠ AVERTISSEMENT :** IL EST TRÈS IMPORTANT DE VÉRIFIER ET DE S'ASSURER QUE CHAQUE BRÛLEUR EST CORRECTEMENT RACCORDÉ À SA VALVE ADJACENTE AVANT DE COMPLÉTER L'ÉTAPE 15. NE PAS FAIRE CELA PEUT CAUSER UN INCENDIE OU EXPLOSION, CAUSANT DES BLESSURES GRAVES OU LA MORT. CONSULTEZ LA SECTION SUR LES INSTRUCTION D'ENTRETIEN AFIN DE VOUS ASSURER QUE L'INSTALLATION EST CORRECTE.

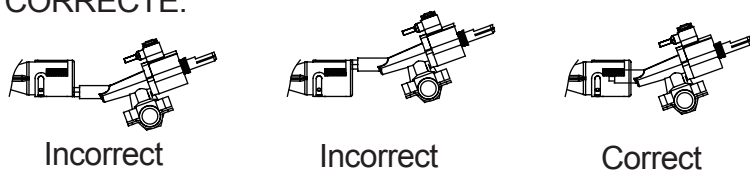

## INSTRUCTIONS POUR L'ASSEMBLAGE

15. Mettre la planche de brûleur (K) à sa place.

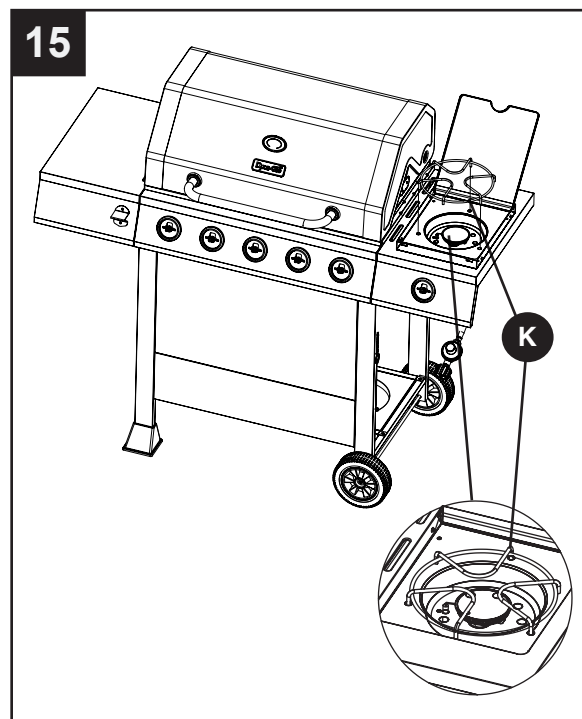

16. Monter les six poignées de commande (D).

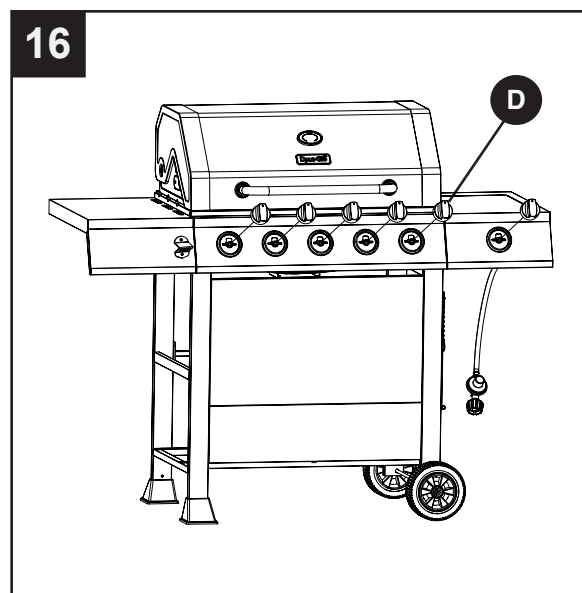



## INSTRUCTIONS POUR L'ASSEMBLAGE

17. Mettre les cinq plaques de chaleurs de barbecue (I) en place au-dessus de chaque brûleur.

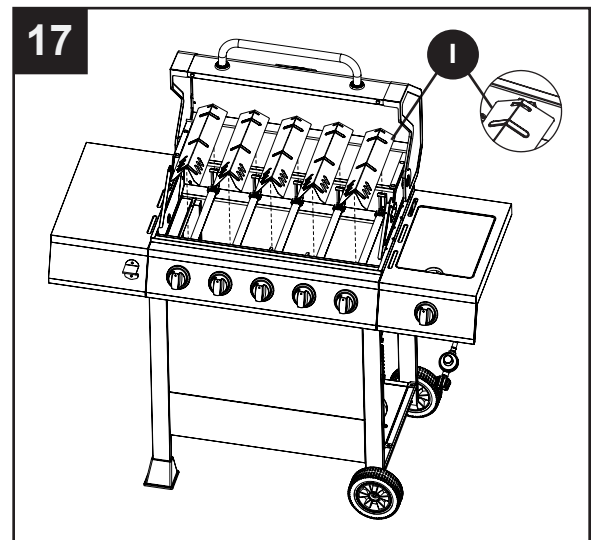

18. Mettre les trois grilles de cuisson (H) et la plaque chauffante G) en place.

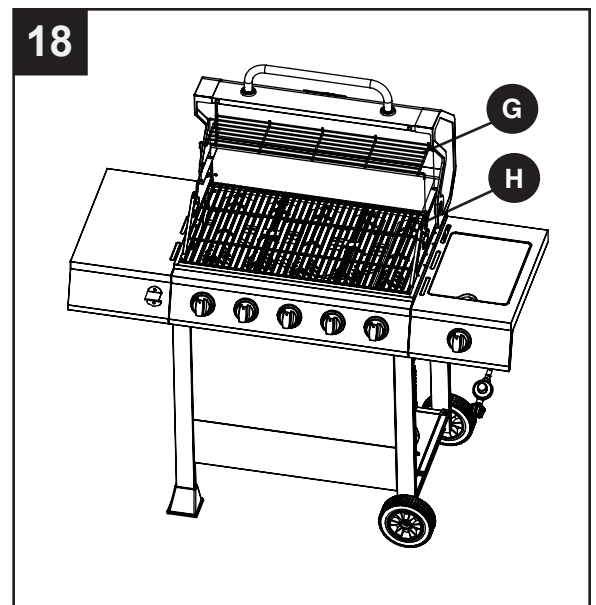

## INSTRUCTIONS POUR L'ASSEMBLAGE

19. Monter le plateau à graisse (E) et godet collecteur (F).

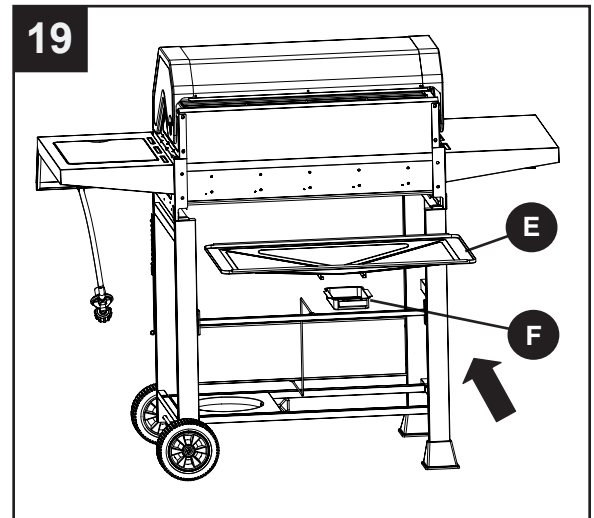

17. Placez la bouteille de gaz (vendue séparément) sur le trou qui se trouve sur l'étagère du bas (W). Tournez la bouteille de gaz afin de pouvoir raccorder le tuyau/détendeur à la valve fileté de la bouteille de PL (propane liquide). Serrez à la main le raccordement du tuyau/détendeur à la valve fileté de la bouteille du PL.

Serrez la vis  de serrement de la bouteille qui se trouve à l'étagère du bas (W), et ce, jusqu'à ce que la bouteille soit installée sécuritairement sur le trou de l'étagère du bas (W).

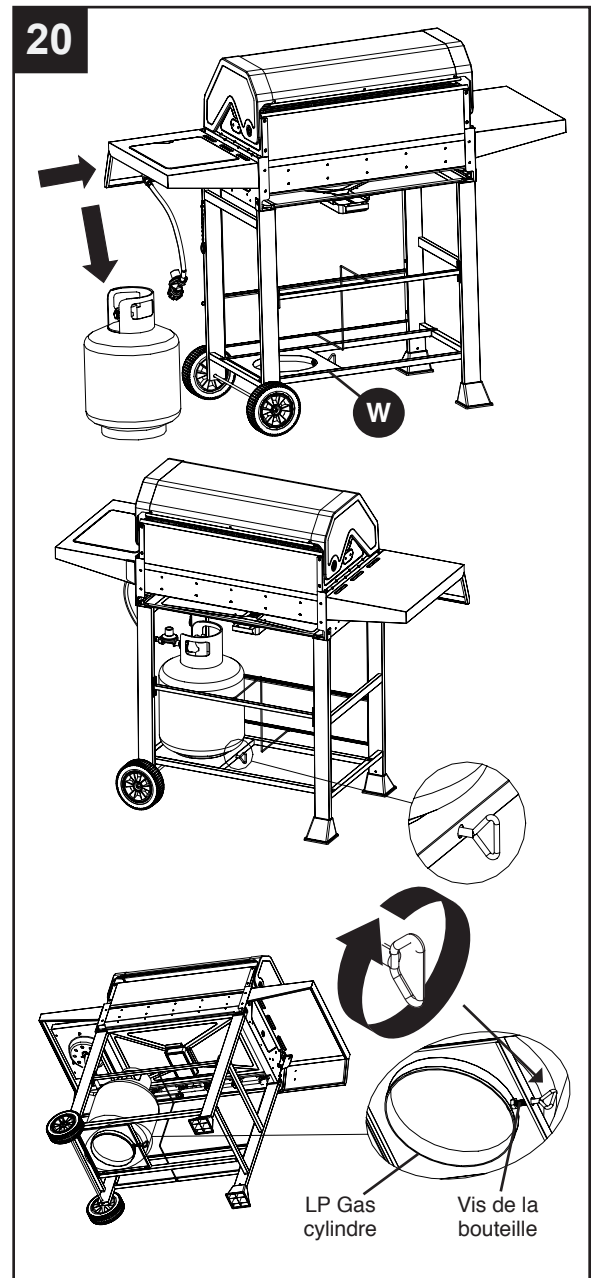
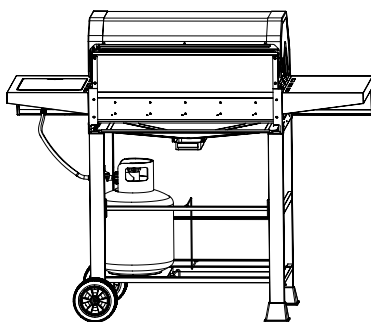
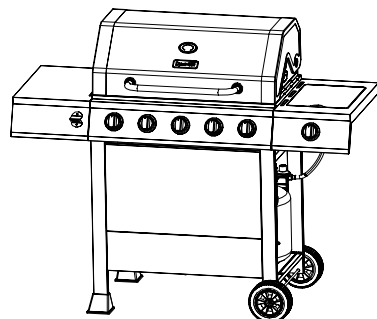

# Dyna-Glo®

## 5 QUEMADORES DE GAS PL PARRILLA DE GAS CON AMPLIA ESTACIÓN DE QUEMADOR

Modelo #DGF510SBP

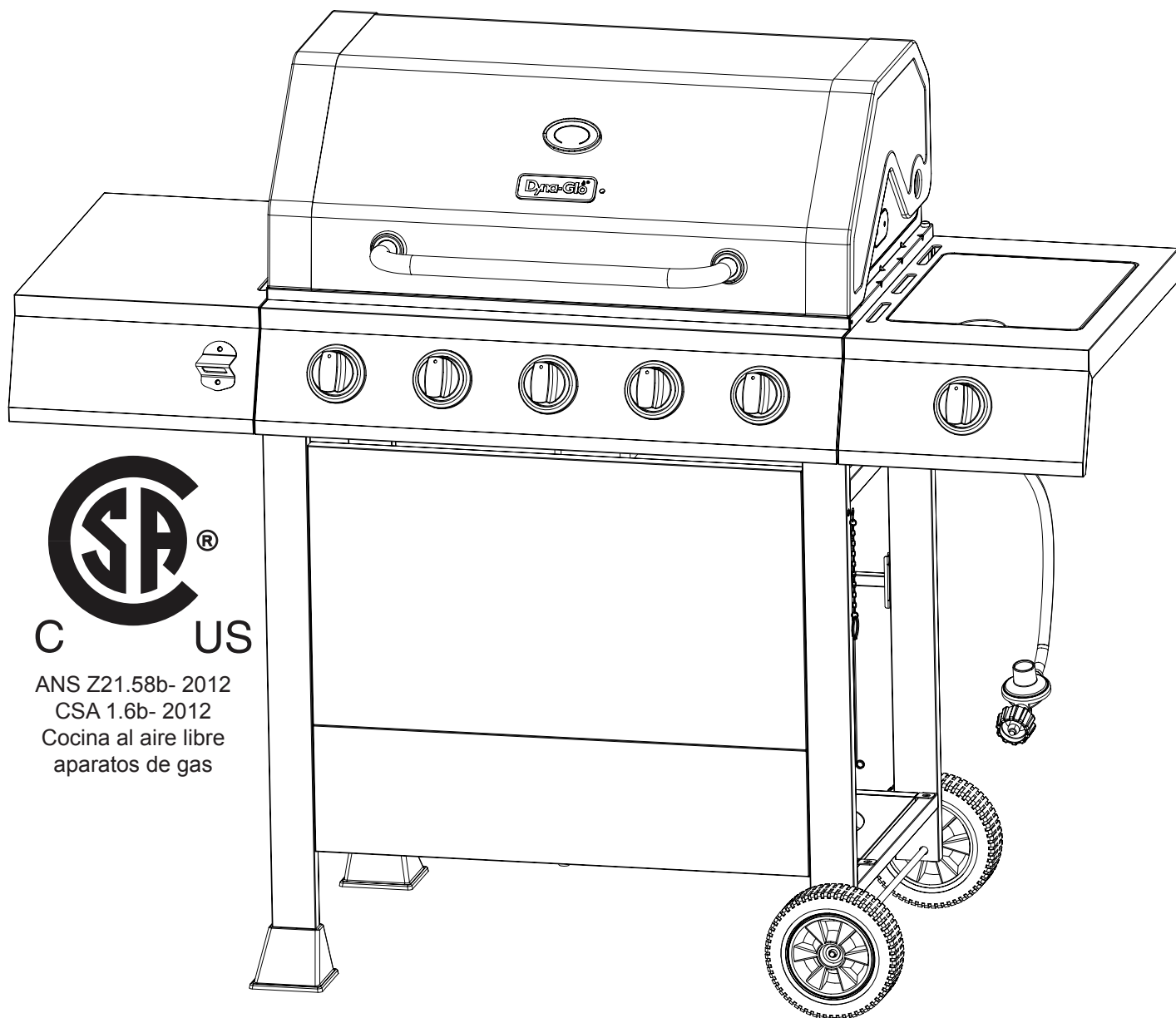

C US

ANS Z21.58b- 2012  
CSA 1.6b- 2012  
Cocina al aire libre  
aparatos de gas

**ADJUNTE SU RECIBO AQUÍ**

Número de serie \_\_\_\_\_ Fecha de compra \_\_\_\_\_



**¿Preguntas, problemas, piezas faltantes?** Antes de volver a la tienda, llame a nuestro Departamento de Servicio al Cliente al 1-877-447-4768, de 8:30 am - 4:30 pm, hora central, de lunes - viernes o envíe un correo electrónico a [customerservice@ghpgroupinc.com](mailto:customerservice@ghpgroupinc.com).



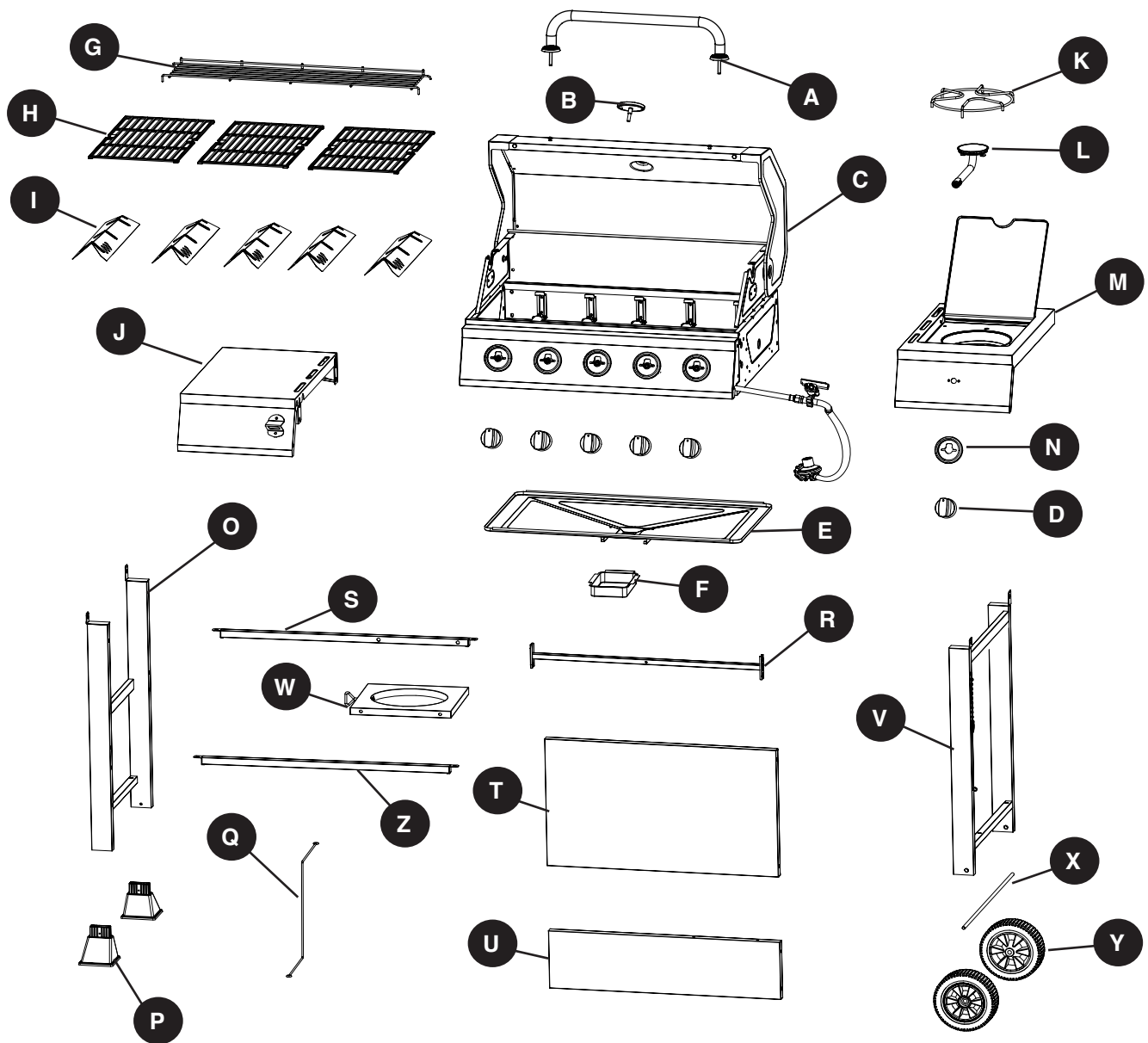





# CONTENIDO DEL PAQUETE

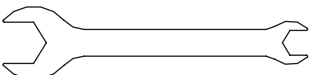

PIEZA	DESCRIPCIÓN	CANT.
A	Conjunto del mango de la tapa	1
B	Indicador de temperature	1
C	Cuerpo de la parrilla	1
D	Botones de control	6
E	Bandeja de grasa	1
F	Gaveta para grasa	1
G	Rejilla para calentar	1
H	Parrillas de cocción	3
I	Tiendas de calor	5
J	Mesa lateral izquierda	1
K	Estante del quemador lateral	1
L	Quemador lateral	1
M	Cuerpo quemador lateral derecho	1
N	Control de bisel de mando	1

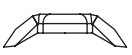
PIEZA	DESCRIPCIÓN	CANT.
O	Conjunto de la pata izquierda	1
P	Tapas	2
Q	Bloque de barra de cilindros	1
R	Conjunto del carrito	1
S	Conjunto frontal en el soporte del estante posterior	1
T	Carrito panel superior frontal	1
U	Carro del panel frontal inferior	1
V	Conjunto de la pata derecho	1
W	Estante inferior	1
X	Eje	1
Y	Ruedas	2
Z	Conjunto frontal en el soporte del estante inferior	1

## ADITAMENTOS (se muestran en tamaño real)

AA	BB	CC	DD	EE	FF
					
ST4.8x10 Tornillo	M10 Tuerca	M10-M6 Llave	M6x16 Tornillo	M5x12 Tornillo	M6 Tuercas de Mariposa
Cant. 2	Cant. 2	Cant. 2	Cant. 34	Cant. 2	Cant. 2
GG	HH	II			
					
M6 Arandela de Seguridad	M6 Arandela	M4x10 Tornillo			
Cant. 2	Cant. 2	Cant. 2			

## PREPARACION

Antes de comenzar a ensamblar el producto, asegúrese de tener todas las piezas. Compare las piezas con la lista del contenido del paquete de la página anterior y los aditamentos que aparecen arriba. No intente ensamblar el producto si falta alguna pieza o si estas están dañadas. Póngase en contacto con el Departamento de Servicio al Cliente para obtener piezas de repuesto.

**Tiempo estimado de ensamblaje:** 50 minutos con 2 personas.

### Herramientas necesarias para el ensamblaje y la prueba de fugas (no se incluyen):

Destornillador Phillips, botella con atomizador, alicates, llave ajustable

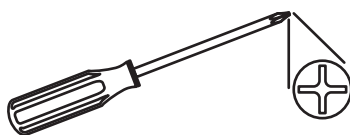

## ⚠ PRECAUCION

**ESTA UNIDAD ES PESADA. SE NECESITAN DOS PERSONAS PARA UN ENSAMBLAJE SEGURO.**

Se requieren dos personas para un ensamblaje segura. Algunas partes pueden presentar bordes filosos. Utilice guantes de protección si es necesario. Lea y siga todas las indicaciones de seguridad, advertencias, instrucciones de ensamblaje, uso y cuidado antes de ensamblar y usar.

## INSTRUCCIONES DE ENSAMBLAJE

1. Ponga dos tapas (P) por debajo del conjunto de la pata izquierda (O) y fíjarlos con dos tornillos ST4. 8x10 (AA).

### Aditamentos utilizados

**AA** ST4.8x10 Tornillo  x 2

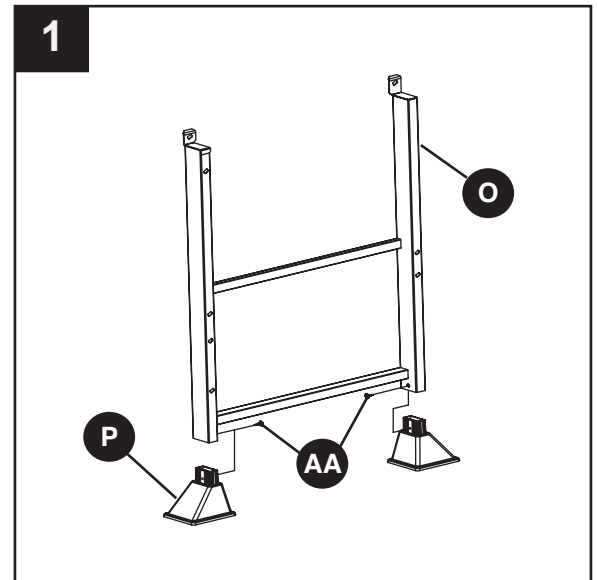

2. Deslice el eje (X) a través del conjunto de la pata derecho (V) y luego ponga las ruedas (Y) en ambos lados y soque las ruedas con la tuerca M10 (BB) con la llave (CC). Por favor note que este paso requiere dos personas para completar, y si es necesario cualquier otro alicates o llave ajustable puede ser utilizado para el ensamblaje.

### Aditamentos utilizados

**BB** M10 Tuerca  x 2

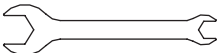
**CC** M10-M6 Llave  x 2

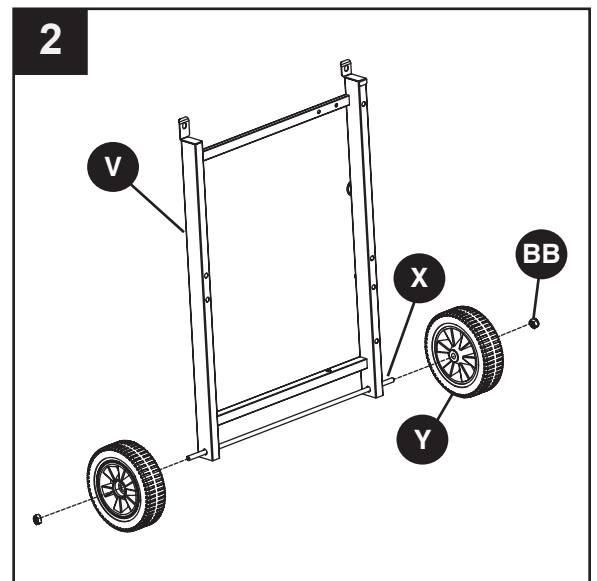

## INSTRUCCIONES DE ENSAMBLAJE

3. Utilice tornillo M6x16 para ensamblar carrito panel superior frontal (T) y el carro del panel frontal inferior (U) entre el conjunto de la pata izquierda (V) y el conjunto de la pata derecha (O). Por favor note la dirección en la que tiene que estar el panel bajo frontal del carrito (U). El lado donde está la tuerca de remache en el medio debe estar hacia abajo.

### Aditamentos utilizados

**DD** M6x16 Tornillo  x 8

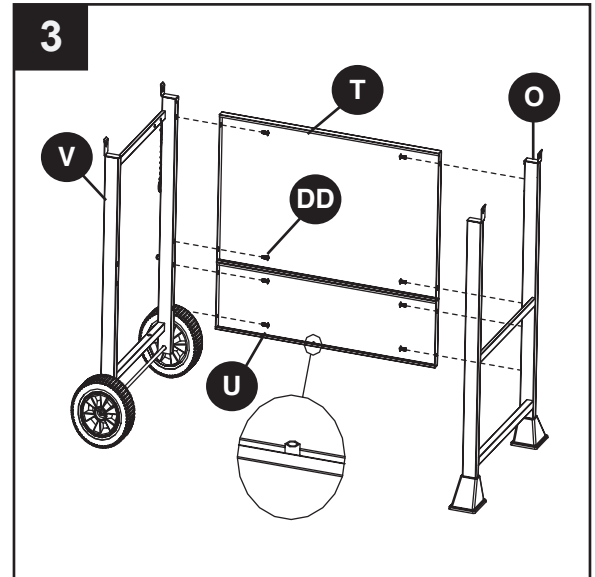

4. Utilice cuatro tornillos M6x16 (DD) para fijar el conjunto frontal en el soporte del estante inferior (Z), ensamblaje del soporte posterior (S) y estante inferior (W).

### Aditamentos utilizados

**DD** M6x16 Tornillo  x 4

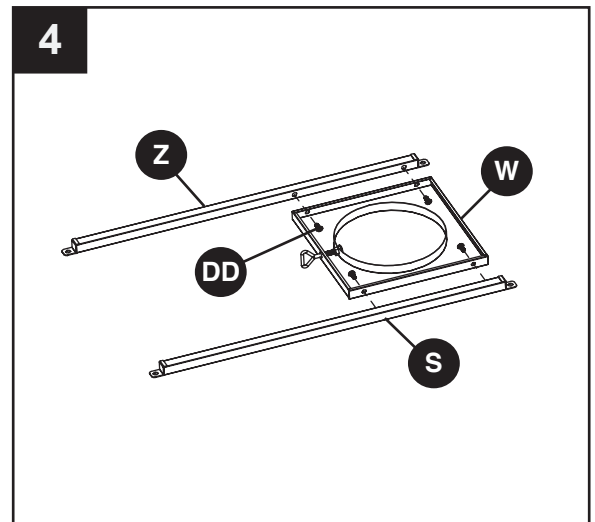

## INSTRUCCIONES DE ENSAMBLAJE

5. Ensamble el montaje del estante inferior al montaje de la pierna izquierda (O) y el montaje de la pierna derecha (V) con cuatro tornillos M6x16 (DD).

### Aditamentos utilizados

**DD** M6x16 Tornillo  x 4

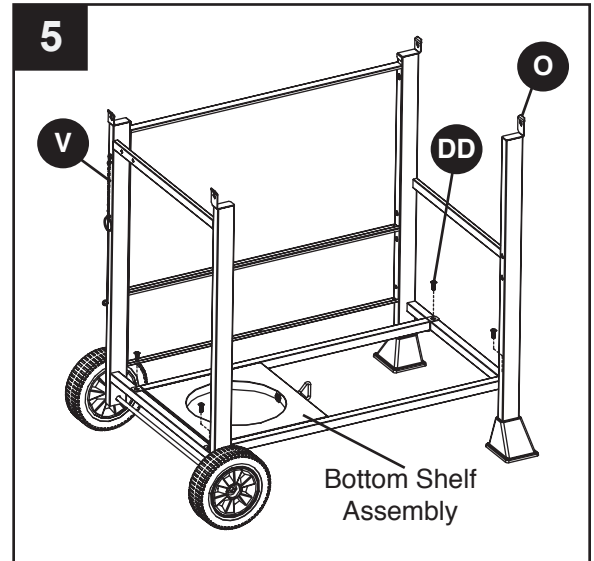

6. Utilice cuatro tornillos M6x16 (DD) para sujetar el soporte del carrito trasero (R) al montaje de la pierna izquierda y derecho, tenga en cuenta que la dirección del soporte del carrito trasero (R), y el lado con la tuerca de remache en el medio deben estar hacia arriba. Y a continuación, utilice dos tornillos M5x12 (EE) para sujetar la barra de bloque de cilindros (Q) entre el panel inferior frontal del carrito (U) y el soporte del carrito trasero (R).

### Aditamentos utilizados

**DD** M6x16 Tornillo  x 4

**EE** M5x12 Tornillo  x 2

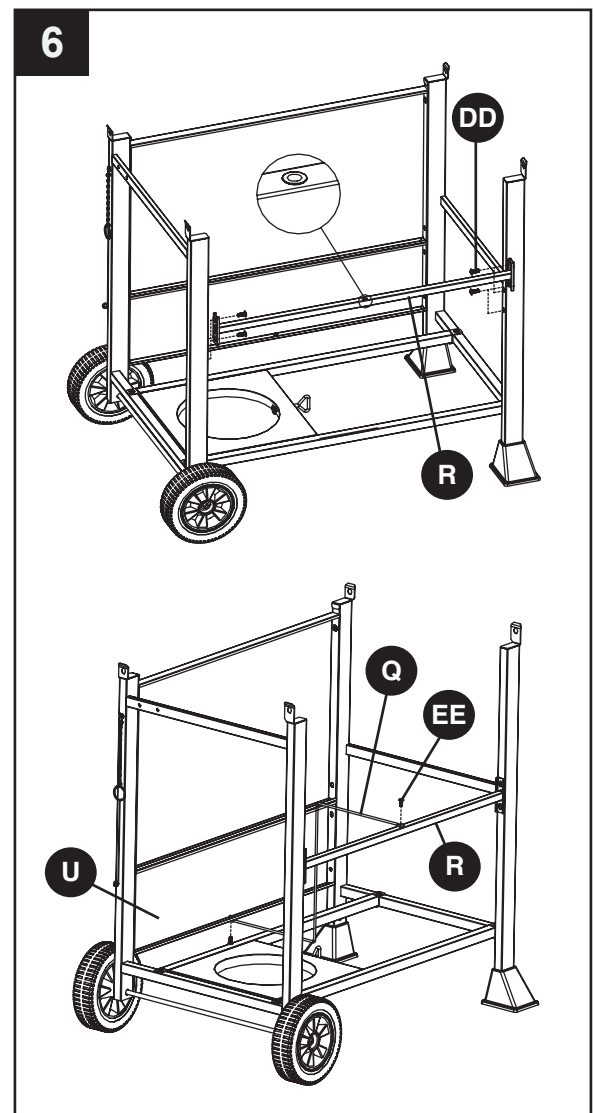





## INSTRUCCIONES DE ENSAMBLAJE

7. Ensamble el conjunto del mango de la tapa (A) a la tapadera con dos tuercas de mariposa (FF) y dos arandelas de seguridad (GG) y dos arandelas M6 (HH).

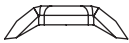
### Aditamentos utilizados

<b>FF</b>	M6 Tuercas de mariposa		x 2
<b>GG</b>	M6 Arandela de seguridad		x 2
<b>HH</b>	M6 Arandela		x 2

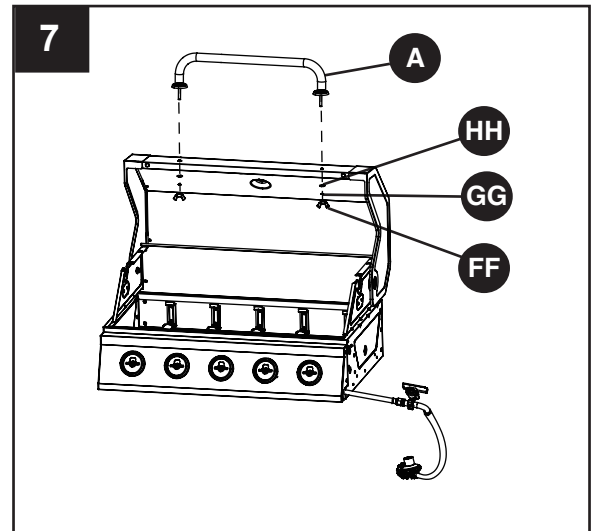

8. Ensamble el indicador de temperatura (B) en la tapa. Por favor usar la arandela y tuerca mariposa pre ensamblada con el medidor de temperatura para instar dicho medidor de temperatura (B) en la campana.

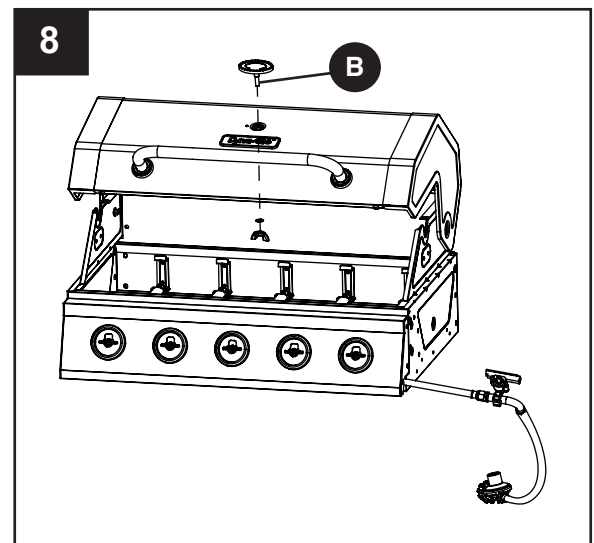

## INSTRUCCIONES DE ENSAMBLAJE

9. Ensamble el conjunto del cuerpo de la parrilla (C) en el conjunto del carro con cuatro tornillos M6x16 (DD).

### Aditamentos utilizados

**DD** M6x16 Tornillo  x 4

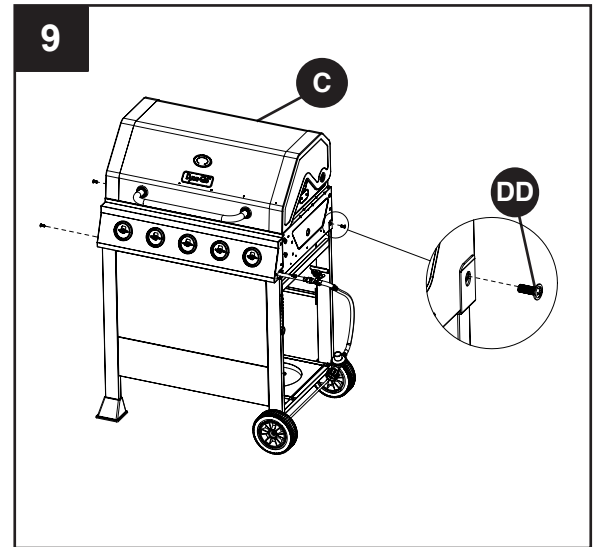

10. Pre-ensamblar dos tornillos M6x16 (DD) en el cuerpo de la parrilla (C) y no los apriete y asegúrese de dejar un espacio de 5 mm entre la tapa del extremo del cuerpo y la parrilla. Luego coloque el conjunto de la mesa lateral izquierda (J) en los tornillos y apriete el conjunto de la mesa lateral izquierda (J) con tres tornillos M6x16 (DD) y apriete todos los tornillos.

### Aditamentos utilizados

**DD** M6x16 Tornillo  x 5

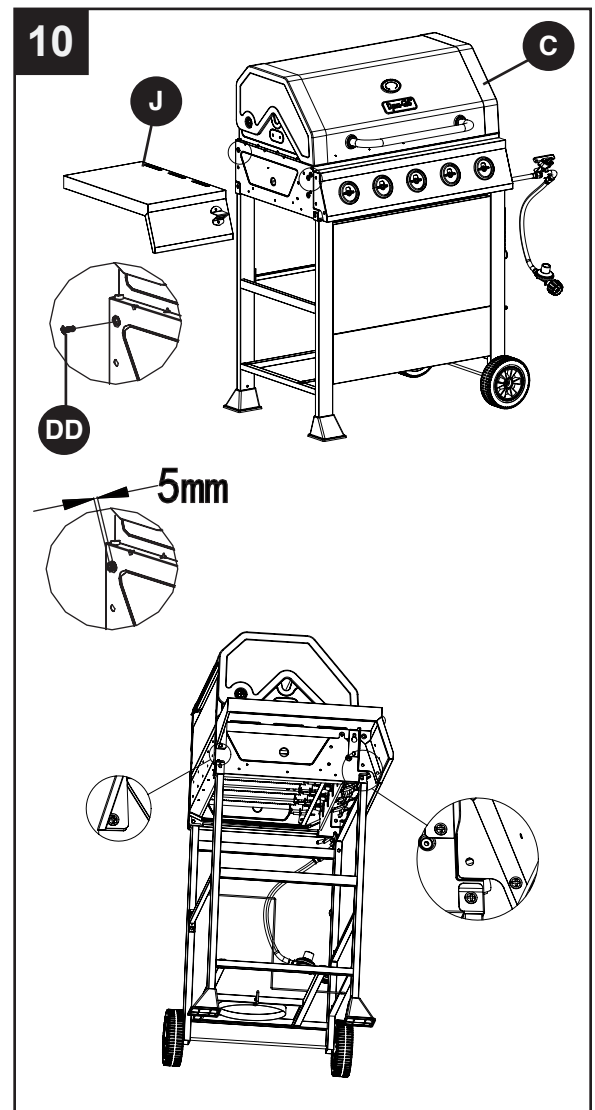

## INSTRUCCIONES DE ENSAMBLAJE

11. Instale 2 M6x16 (DD) tornillos al lado derecho del cuerpo de la parrilla (C) como se muestra, dejando 5 mm de roscas expuestas, alinee el agujero clave en conjunto de la mesa lateral izquierda (M) a los 2 tornillos apenas instalados en el cuerpo de la parrilla (C), e instalar otros 3 M6x16 (DD) tornillos en los agujeros que quedan en el cuerpo de la parrilla (C). Ajuste la mesa del lado derecho (M) correctamente y apriete todos los tornillos.

### Aditamentos utilizados

**DD** M6x16 Tornillo  x 5

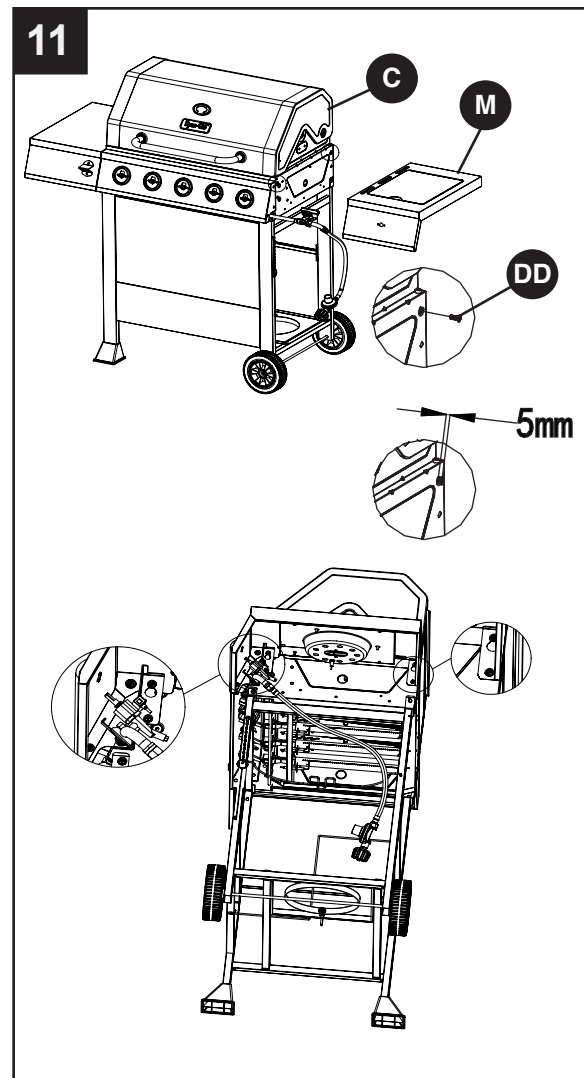

12. Utilice dos tornillos M4x10 (II) para ensamblar el conjunto de la válvula del quemador lateral y el bisel perilla de control (N) al cuerpo del quemador lateral derecho.

### Aditamentos utilizados

**II** M4x10 Tornillo  x 2

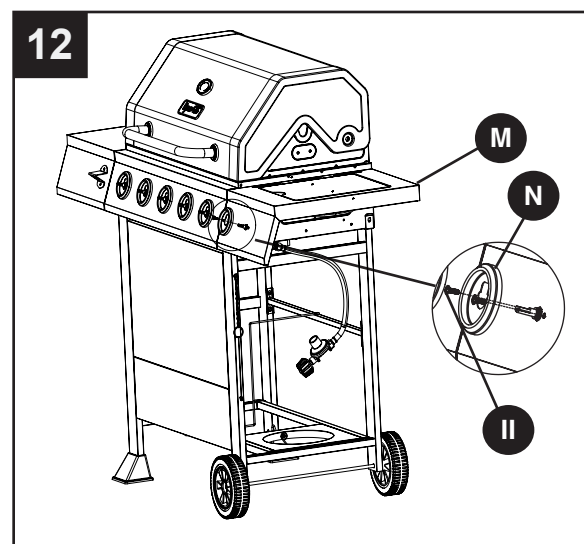

## INSTRUCCIONES DE ENSAMBLAJE

13. Desmontar dos tornillos M4x10 que están pre-ensamblados en el quemador lateral (L) y use los para ensamblar el quemador lateral al cuerpo del quemador lateral (M). Por favor asegúrese el orificio de la válvula de gas este en la posición correcta dentro de la entrada del quemador lateral (venturi).

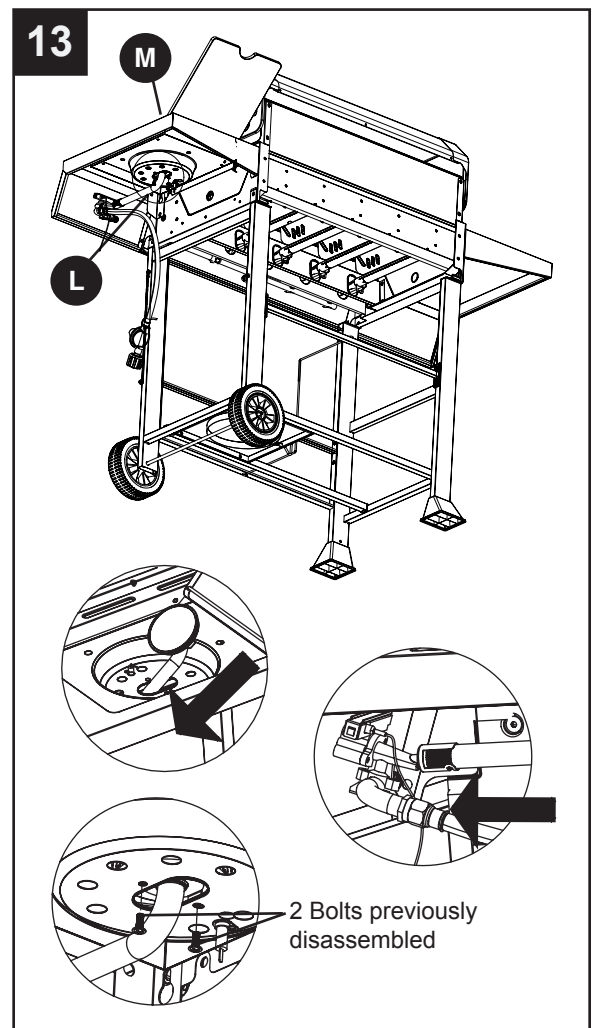
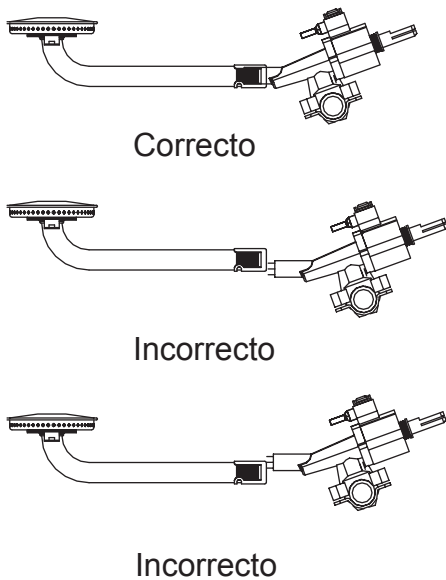

14. Conecte el cable de chispa del quemador lateral al sparker del quemador lateral.

**⚠ ADVERTENCIA:** ES MUY IMPORTANTE PARA COMPROBAR Y ASEGURAR QUE CADA QUEMADOR ESTÁ PLENAMENTE COMPROMETIDA CON LA VÁLVULA ADYACENTE ORIFICIO ANTES DE COMPLETAR EL PASO 15. NO HACERLO DE MAYO PROVOCAR UN INCENDIO O EXPLOSIÓN, POSIBLEMENTE CAUSAR GRAVES LESIONES O MUERTE. CONSULTE EL MANTENIMIENTO INSTRUCCIONES PARA SECCIÓN APROPIADAMENTE REVISÉ EL COMPROMISO.

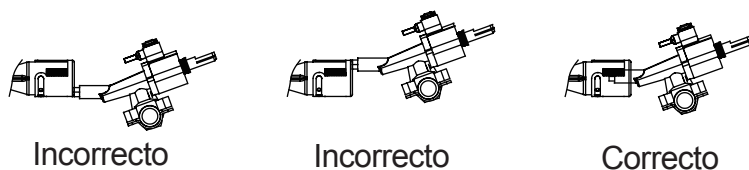

## INSTRUCCIONES DE ENSAMBLAJE

15. Coloquela rejilla del quemador lateral (K) en su lugar.

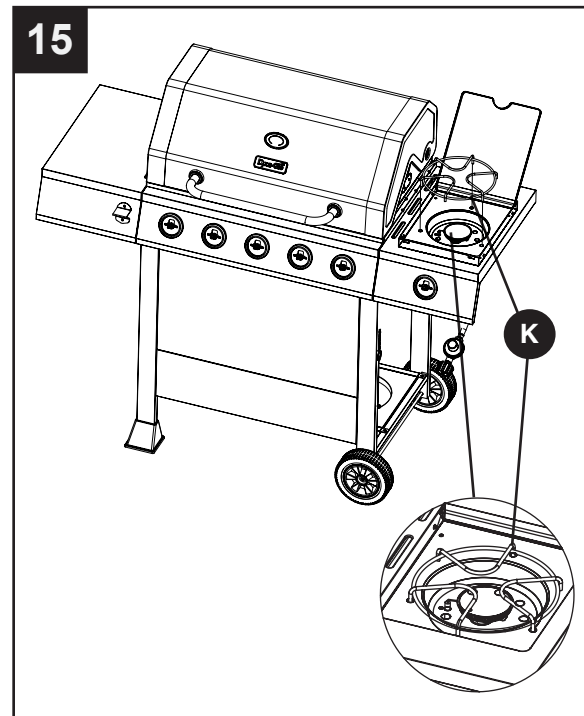

16. Ensamble los seis botones de control (D).

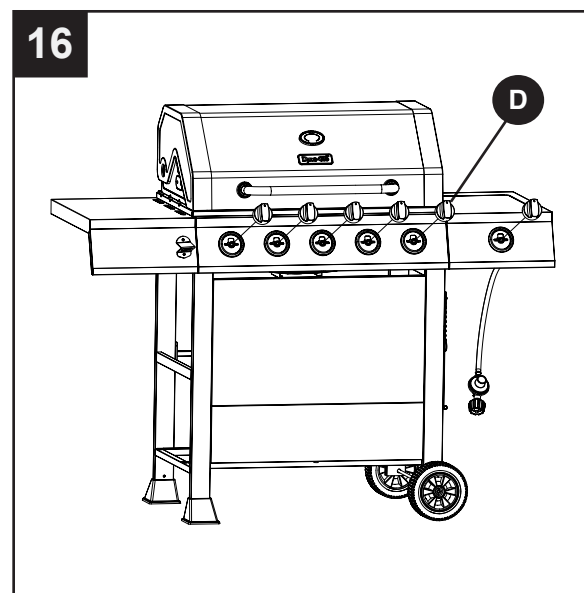

## INSTRUCCIONES DE ENSAMBLAJE

17. Ponga las cuatro tiendas de calor (I) en su lugar sobre cada hornilla.

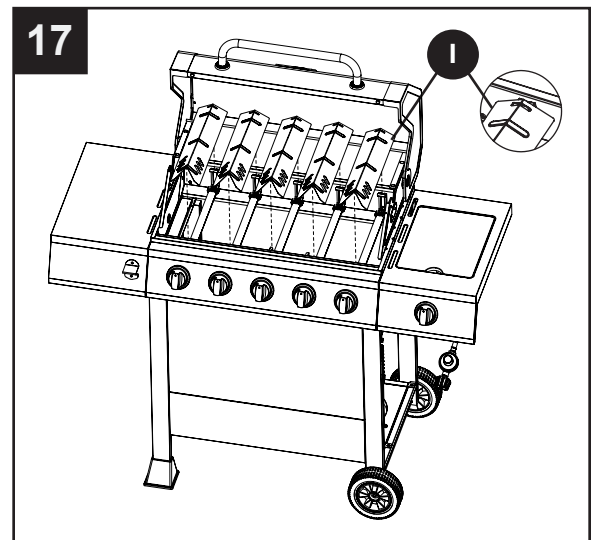

18. Ponga las tres parrillas de cocción (G) y la rejilla para calentar (H) en su lugar.

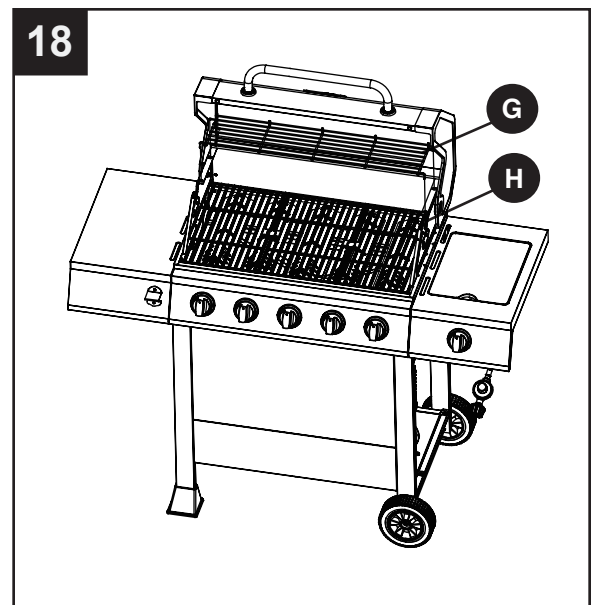

## INSTRUCCIONES DE ENSAMBLAJE

19. Ensamble la bandeja de grasa (E) y la gaveta para grasa (F).

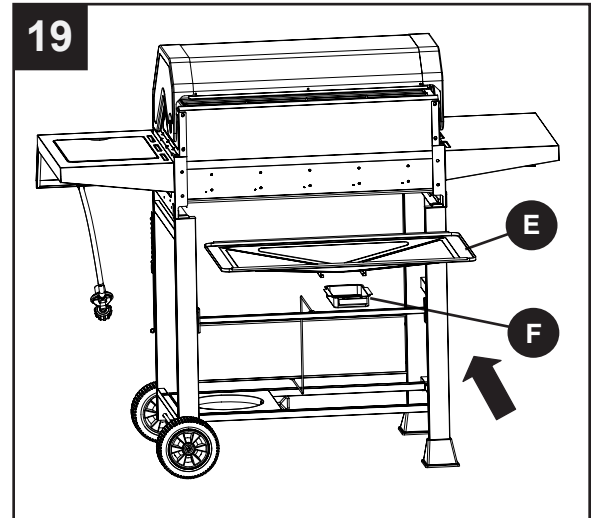

17. El lugar cilindro de gas (se vende por separado) en el agujero de encaje situado en el estante inferior (W). Gire el cilindro de gas hasta que el acoplamiento de la manguera / regulador de la válvula roscada del cilindro de gas LP hasta que el acoplamiento de la manguera / regulador a la válvula roscada del cilindro de gas LP.

Apriete el tornillo del tanque en la parte trasera del carro hasta que el cilindro se asegura en su estante inferior (W) del agujero de encaje del estante inferior (W).

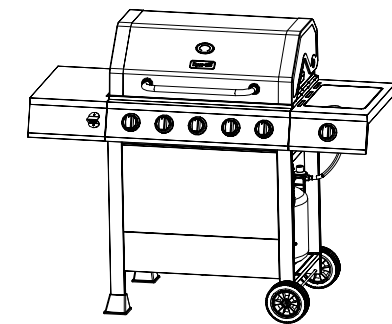

Vista Frontal

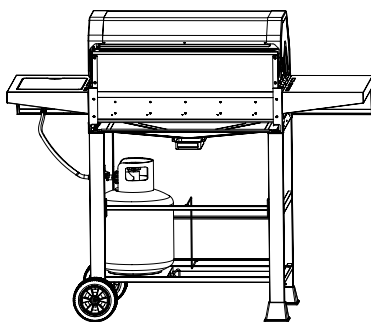

Vista Trasera

