

Grizzly **Industrial, Inc.**®

MODEL G0690/G0691 10" CABINET TABLE SAW w/RIVING KNIFE OWNER'S MANUAL



Model G0691



Model G0690

C US
232857

COPYRIGHT © NOVEMBER, 2008 BY GRIZZLY INDUSTRIAL, INC. REVISED MAY, 2018 (HE)
**WARNING: NO PORTION OF THIS MANUAL MAY BE REPRODUCED IN ANY SHAPE
OR FORM WITHOUT THE WRITTEN APPROVAL OF GRIZZLY INDUSTRIAL, INC.**
(FOR MODELS MANUFACTURED SINCE 9/11) #BL11376 PRINTED IN CHINA

V2.05.18



WARNING!

This manual provides critical safety instructions on the proper setup, operation, maintenance, and service of this machine/tool. Save this document, refer to it often, and use it to instruct other operators.

Failure to read, understand and follow the instructions in this manual may result in fire or serious personal injury—including amputation, electrocution, or death.

The owner of this machine/tool is solely responsible for its safe use. This responsibility includes but is not limited to proper installation in a safe environment, personnel training and usage authorization, proper inspection and maintenance, manual availability and comprehension, application of safety devices, cutting/sanding/grinding tool integrity, and the usage of personal protective equipment.

The manufacturer will not be held liable for injury or property damage from negligence, improper training, machine modifications or misuse.



WARNING!

Some dust created by power sanding, sawing, grinding, drilling, and other construction activities contains chemicals known to the State of California to cause cancer, birth defects or other reproductive harm. Some examples of these chemicals are:

- **Lead from lead-based paints.**
- **Crystalline silica from bricks, cement and other masonry products.**
- **Arsenic and chromium from chemically-treated lumber.**

Your risk from these exposures varies, depending on how often you do this type of work. To reduce your exposure to these chemicals: Work in a well ventilated area, and work with approved safety equipment, such as those dust masks that are specially designed to filter out microscopic particles.

Table of Contents

INTRODUCTION	2	SECTION 5: SHOP MADE SAFETY	
Contact Info.....	2	ACCESSORIES	50
Manual Accuracy	2	Featherboards.....	50
Identification.....	3	Push Sticks	53
G0690 Machine Data Sheet	4	Push Blocks	54
G0691 Machine Data Sheet	7	Narrow-Rip Auxiliary Fence & Push Block ..	55
SECTION 1: SAFETY	10	Outfeed & Support Tables	57
Safety Instructions for Machinery	10	Crosscut Sled.....	57
Additional Safety for Table Saws.....	12	SECTION 6: ACCESSORIES	58
Preventing Kickback	13	SECTION 7: MAINTENANCE	61
Protecting Yourself From Kickback.....	13	Schedule	61
Glossary of Terms	14	Cleaning.....	61
SECTION 2: POWER SUPPLY	15	Lubrication	62
SECTION 3: SETUP	17	SECTION 8: SERVICE	63
Items Needed for Setup.....	17	Troubleshooting	63
Unpacking	17	Blade Tilt Stops.....	65
Hardware Recognition Chart	18	Miter Slot to Blade Parallelism.....	67
Inventory	19	Spreader or Riving Knife Alignment	68
Fence Inventory G0690	20	Fence Adjustments	69
Fence Inventory G0691	20	Fence Scale Calibration.....	71
Cleanup.....	21	Miter Gauge Adjustments	72
Site Considerations.....	22	Belt Tension & Replacement	73
Assembly	23	SECTION 9: WIRING	74
Dust Collection.....	30	Wiring Safety Instructions	74
Power Connection.....	30	Model G0690/G0691 Wiring Diagram.....	75
Test Run	31	SECTION 10: PARTS	76
Recommended Adjustments.....	31	Body.....	76
SECTION 4: OPERATIONS	32	Trunnion.....	78
Operation Overview	32	Blade Guard.....	81
Basic Controls.....	33	Miter Gauge	82
Non-Through & Through Cuts	33	Fence	83
Workpiece Inspection.....	34	Extension Table (G0690).....	84
Blade Requirements	34	Extension Table (G0691).....	85
Blade Selection	34	Labels and Cosmetics	86
Blade Installation.....	36	WARRANTY AND RETURNS	89
Blade Guard Assembly	37		
Riving Knife.....	39		
Ripping.....	40		
Crosscutting	41		
Miter Cuts.....	41		
Blade Tilt/Bevel Cuts	42		
Dado Cutting	42		
Rabbet Cutting.....	45		
Resawing	47		

INTRODUCTION

Contact Info

We stand behind our machines! If you have questions or need help, contact us with the information below. Before contacting, make sure you get the **serial number** and **manufacture date** from the machine ID label. This will help us help you faster.

Grizzly Technical Support
1815 W. Battlefield
Springfield, MO 65807
Phone: (570) 546-9663
Email: techsupport@grizzly.com

We want your feedback on this manual. What did you like about it? Where could it be improved? Please take a few minutes to give us feedback.

Grizzly Documentation Manager
P.O. Box 2069
Bellingham, WA 98227-2069
Email: manuals@grizzly.com

Manual Accuracy

We are proud to provide a high-quality owner's manual with your new machine!

We made every effort to be exact with the instructions, specifications, drawings, and photographs in this manual. Sometimes we make mistakes, but our policy of continuous improvement also means that **sometimes the machine you receive is slightly different than shown in the manual.**

If you find this to be the case, and the difference between the manual and machine leaves you confused or unsure about something, check our website for an updated version. We post current manuals and manual updates for free on our website at www.grizzly.com.

Alternatively, you can call our Technical Support for help. Before calling, make sure you write down the **Manufacture Date** and **Serial Number** from the machine ID label (see below). This information is required for us to provide proper tech support, and it helps us determine if updated documentation is available for your machine.

		MODEL GXXXX MACHINE NAME	
SPECIFICATIONS		▲ WARNING!	
Motor:	To reduce risk of serious injury when using this machine:		
Specification:	Read manual before operation.		
Specification:	Wear safety glasses and respirator.		
Specification:	Ensure safety is correctly adjusted/setup and		
Specification:	power is connected to grounded circuit before starting.		
Weight:	4. Make sure the motor has stopped and disconnect		
	power before adjustments, maintenance, or service.		
	5. DO NOT expose to rain or dampness.		
	6. DO NOT modify this machine in any way.		
	7.		
	8.		
	9. Do not use while tired, drowsy, or under the influence of drugs or alcohol.		
	10. Maintain machine carefully to prevent accidents.		
	Manufactured for Grizzly in Taiwan		

Manufacture Date

Serial Number



Identification

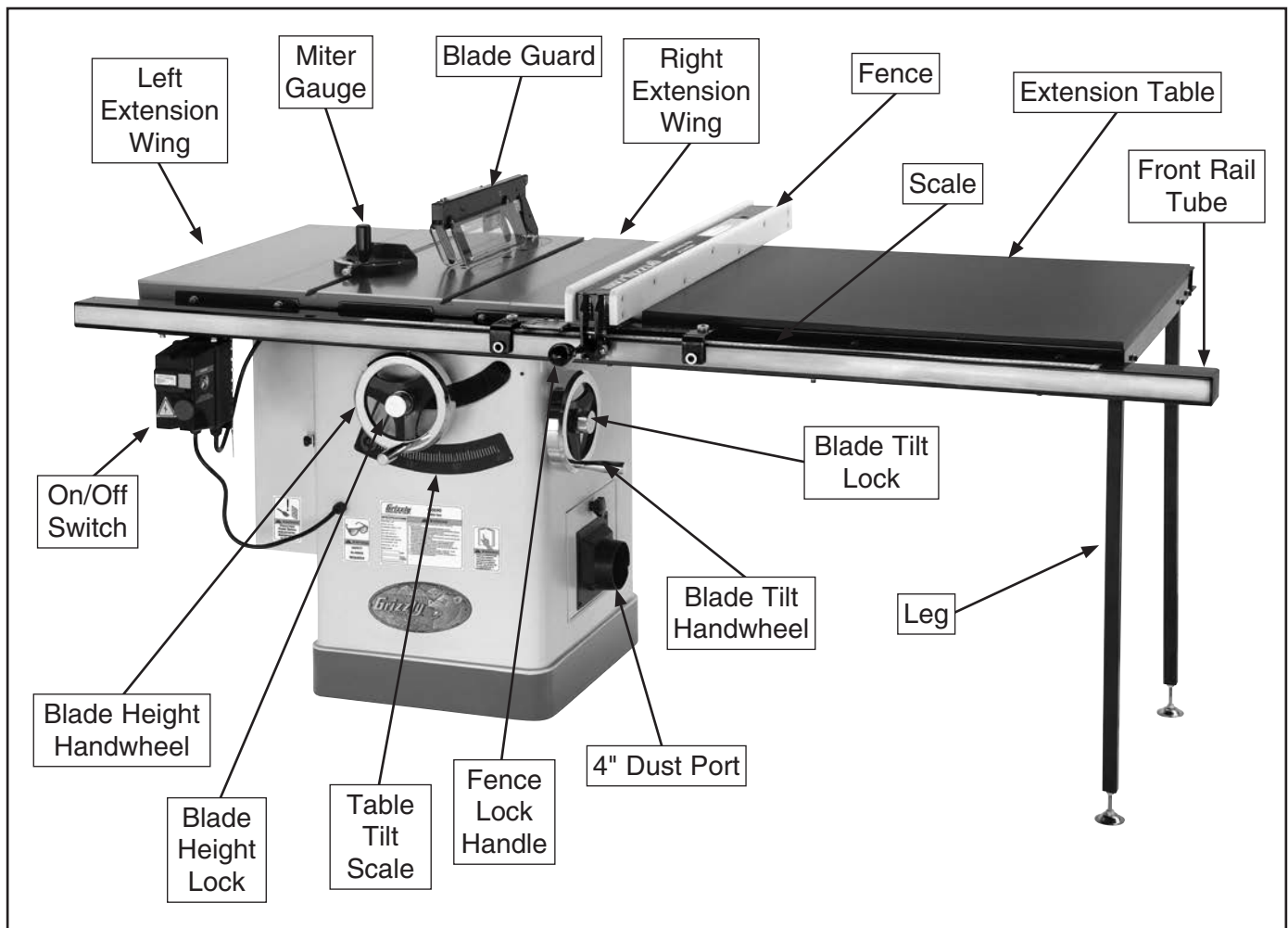

Figure 1. Identification (Model G0691 shown).

⚠ CAUTION

For Your Own Safety Read Instruction Manual Before Operating Saw

- a) Wear eye protection.
- b) Use saw-blade guard and spreader for every operation for which it can be used, including all through sawing.
- c) Keep hands out of the line of saw blade.
- d) Use a push-stick when required.
- e) Pay particular attention to instructions on reducing risk of kickback.
- f) Do not perform any operation freehand.
- g) Never reach around or over saw blade.





MACHINE DATA SHEET

Customer Service #: (570) 546-9663 · To Order Call: (800) 523-4777 · Fax #: (800) 438-5901

MODEL G0690 10" 3HP 220V CABINET TABLE SAW WITH RIVING KNIFE

Product Dimensions:

Weight..... 507 lbs.
 Width (side-to-side) x Depth (front-to-back) x Height..... 62 x 41 x 40 in.
 Footprint (Length x Width)..... 20 x 20 in.
 Space Required for Full Range of Movement (Width x Depth)..... 62 x 45-1/2 in.

Shipping Dimensions:

Carton #1

Type..... Cardboard Box on Wood Skids
 Content..... Machine
 Weight..... 462 lbs.
 Length x Width x Height..... 33 x 30 x 40 in.
 Must Ship Upright..... Yes

Carton #2

Type..... Cardboard Box
 Content..... Fence
 Weight..... 24 lbs.
 Length x Width x Height..... 42 x 17 x 7 in.
 Must Ship Upright..... No

Carton #3

Type..... Cardboard Box
 Content..... Rails
 Weight..... 44 lbs.
 Length x Width x Height..... 66 x 7 x 5 in.
 Must Ship Upright..... No

Electrical:

Power Requirement..... 220V, Single-Phase, 60 Hz
 Prewired Voltage..... 220V
 Full-Load Current Rating..... 12.8A
 Minimum Circuit Size..... 20A
 Connection Type..... Cord & Plug
 Power Cord Included..... Yes
 Power Cord Length..... 6 ft.
 Power Cord Gauge..... 14 AWG
 Plug Included..... Yes
 Included Plug Type..... 6-20
 Switch Type..... Magnetic Switch w/Overload Protection & Disabling Pin



Motors:

Main

Horsepower.....	3 HP
Phase.....	Single-Phase
Amps.....	12.8A
Speed.....	3450 RPM
Type.....	TEFC Capacitor-Start Induction
Power Transfer	Triple V-Belt Drive
Bearings.....	Shielded & Permanently Lubricated
Centrifugal Switch/Contacts Type.....	Internal

Main Specifications:

Main Information

Table Saw Type.....	Cabinet
Maximum Blade Diameter.....	10 in.
Arbor Size.....	5/8 in.
Arbor Speed.....	4300 RPM
Maximum Width of Dado.....	13/16 in.
Blade Tilt Direction.....	Left
Max Blade Tilt.....	45 deg.
Maximum Depth of Cut At 90 Degrees.....	3-1/8 in.
Maximum Depth of Cut At 45 Degrees.....	2-3/16 in.
Max Rip Right of Blade w/Included Fence & Rails.....	29-1/2 in.
Max Rip Left of Blade w/Included Fence & Rails.....	12 in.

Additional Blade Information

Included Blade Information.....	10" x 40T
Riving Knife/Spreader Thickness.....	0.100 in.
Required Blade Body Thickness.....	0.071 – 0.094 in.
Required Blade Kerf Thickness.....	0.102 – 0.126 in.
Rim Speed at Max Blade Diameter.....	11,300 FPM

Table Information

Floor to Table Height.....	34 in.
Table Size with Extension Wings Width.....	40 in.
Table Size with Extension Wings Depth.....	27 in.
Distance Front of Table to Center of Blade.....	17-1/4 in.
Distance Front of Table to Blade At Maximum Cut.....	12-1/4 in.
Main Table Size Thickness.....	1-1/2 in.

Fence Information

Fence Type.....	Camlock T-Shape w/HDPE Face
Fence Size Length.....	48 in.
Fence Size Width.....	4-1/8 in.
Fence Size Height.....	2-1/2 in.
Fence Rail Type.....	Square Steel Tubing
Fence Rail Length.....	62 in.
Fence Rail Width.....	2-3/4 in.
Fence Rail Height.....	2 in.

Miter Gauge Information

Miter Gauge Slot Type.....	T-Slot
Miter Gauge Slot Size Width.....	3/4 in.
Miter Gauge Slot Size Height.....	3/8 in.



Construction

Table.....	Precision-Ground Cast Iron
Wings.....	Precision-Ground Cast Iron
Cabinet.....	Pre-Formed Steel
Trunnions.....	Cast Iron
Fence Assembly.....	Steel with HDPE Side Plates
Rails.....	Steel
Miter Guage Construction.....	Cast Iron with Steel Bar
Guard.....	Steel and Clear Plastic
Body/Cabinet Paint Type/Finish.....	Powder Coated
Arbor Bearings.....	Sealed & Permanently Lubricated

Other Related Information

Number of Dust Ports.....	1
Dust Port Size.....	4 in.
Compatible Mobile Base.....	D2057A

Other Specifications:

Country of Origin	China
Warranty	1 Year
Approximate Assembly & Setup Time	1 Hour
Serial Number Location	ID Label on Cabinet
ISO 9001 Factory	Yes
Certified by a Nationally Recognized Testing Laboratory (NRTL)	Yes

Features:

- Quick-Release Blade Guard and Spreader
- Quick Release Riving Knife
- Hinged Motor Cover
- 4" Dust Port
- Heavy-Duty Handwheels
- Heavy-Duty T-Slot Miter Gauge
- Triple V-Belts
- Precision-Ground Cast-Iron Table
- High Quality 3 HP Motor
- Heavy-Duty Cast-Iron Trunnions
- Powder Coated Paint
- Camlock T-Shaped Fence with HDPE Face
- Easy Glide Fence System
- Knurled Knobs for Adjusting Fence
- Nylon Runners Inside Fence Head Assembly
- Standard and Dado Table Inserts
- Recessed Screw Holding Table Insert
- Included 10" x 40T Carbide-Tipped Blade

Accessories Recommended:

- T24862 Long Rail Kit for G0690





MACHINE DATA SHEET

Customer Service #: (570) 546-9663 · To Order Call: (800) 523-4777 · Fax #: (800) 438-5901

MODEL G0691 10" 3HP 220V CABINET TABLE SAW WITH LONG RAILS & RIVING KNIFE

Product Dimensions:

Weight..... 546 lbs.
 Width (side-to-side) x Depth (front-to-back) x Height..... 82 x 41 x 40 in.
 Footprint (Length x Width)..... 20 x 20 in.
 Space Required for Full Range of Movement (Width x Depth)..... 82 x 45-1/2 in.

Shipping Dimensions:

Carton #1

Type..... Cardboard Box on Wood Skids
 Content..... Machine
 Weight..... 465 lbs.
 Length x Width x Height..... 24 x 30 x 42 in.
 Must Ship Upright..... Yes

Carton #2

Type..... Cardboard Box
 Content..... Fence
 Weight..... 26 lbs.
 Length x Width x Height..... 42 x 17 x 7 in.
 Must Ship Upright..... No

Carton #3

Type..... Cardboard Box
 Content..... Rails
 Weight..... 66 lbs.
 Length x Width x Height..... 67 x 7 x 5 in.
 Must Ship Upright..... No

Electrical:

Power Requirement..... 220V, Single-Phase, 60 Hz
 Prewired Voltage..... 220V
 Full-Load Current Rating..... 12.8A
 Minimum Circuit Size..... 20A
 Connection Type..... Cord & Plug
 Power Cord Included..... Yes
 Power Cord Length..... 6 ft.
 Power Cord Gauge..... 14 AWG
 Plug Included..... Yes
 Included Plug Type..... 6-20
 Switch Type..... Magnetic Switch w/Overload Protection & Disabling Pin



Motors:

Main

Horsepower.....	3 HP
Phase.....	Single-Phase
Amps.....	12.8A
Speed.....	3450 RPM
Type.....	TEFC Capacitor-Start Induction
Power Transfer	Triple V-Belt Drive
Bearings.....	Shielded & Permanently Lubricated
Centrifugal Switch/Contacts Type.....	Internal

Main Specifications:

Main Information

Table Saw Type.....	Cabinet
Maximum Blade Diameter.....	10 in.
Arbor Size.....	5/8 in.
Arbor Speed.....	4300 RPM
Maximum Width of Dado.....	13/16 in.
Blade Tilt Direction.....	Left
Max Blade Tilt.....	45 deg.
Maximum Depth of Cut At 90 Degrees.....	3-1/8 in.
Maximum Depth of Cut At 45 Degrees.....	2-3/16 in.
Max Rip Right of Blade w/Included Fence & Rails.....	49 in.
Max Rip Left of Blade w/Included Fence & Rails.....	12 in.

Additional Blade Information

Included Blade Information.....	10" x 40T
Riving Knife/Spreader Thickness.....	0.100 in.
Required Blade Body Thickness.....	0.071 – 0.094 in.
Required Blade Kerf Thickness.....	0.102 – 0.126 in.
Rim Speed at Max Blade Diameter.....	11,300 FPM

Table Information

Floor to Table Height.....	34 in.
Table Size with Extension Wings Width.....	74-3/4 in.
Table Size with Extension Wings Depth.....	27 in.
Distance Front of Table to Center of Blade.....	17-1/4 in.
Distance Front of Table to Blade At Maximum Cut.....	12-1/4 in.
Main Table Size Thickness.....	1-1/2 in.

Fence Information

Fence Type.....	Camlock T-Shape w/HDPE Face
Fence Size Length.....	48 in.
Fence Size Width.....	4-1/8 in.
Fence Size Height.....	2-1/2 in.
Fence Rail Type.....	Square Steel Tubing
Fence Rail Length.....	62 in.
Fence Rail Width.....	2-3/4 in.
Fence Rail Height.....	2 in.

Miter Gauge Information

Miter Gauge Slot Type.....	T-Slot
Miter Gauge Slot Size Width.....	3/4 in.
Miter Gauge Slot Size Height.....	3/8 in.



Construction

Table.....	Precision-Ground Cast Iron
Wings.....	Precision-Ground Cast Iron
Cabinet.....	Pre-Formed Steel
Trunnions.....	Cast Iron
Fence Assembly.....	Steel with HDPE Side Plates
Rails.....	Steel
Miter Guage Construction.....	Cast Iron with Steel Bar
Guard.....	Steel and Clear Plastic
Body/Cabinet Paint Type/Finish.....	Powder Coated
Arbor Bearings.....	Sealed & Permanently Lubricated

Other Related Information

Number of Dust Ports.....	1
Dust Port Size.....	4 in.
Compatible Mobile Base.....	D2057A

Other Specifications:

Country of Origin	China
Warranty	1 Year
Approximate Assembly & Setup Time	1 Hour
Serial Number Location	ID Label on Cabinet
ISO 9001 Factory	Yes
Certified by a Nationally Recognized Testing Laboratory (NRTL)	Yes

Features:

- Quick-Release Blade Guard and Spreader
- Quick Release Riving Knife
- Hinged Motor Cover
- 4" Dust Port
- Heavy-Duty Handwheels
- Heavy-Duty T-Slot Miter Gauge
- Triple V-Belts
- Precision-Ground Cast-Iron Table
- High Quality 3 HP Motor
- Heavy-Duty Cast-Iron Trunnions
- Powder Coated Paint
- Camlock T-Shaped Fence with HDPE Face
- Easy Glide Fence System
- Knurled Knobs for Adjusting Fence
- Nylon Runners Inside Fence Head Assembly
- Standard and Dado Table Inserts
- Recessed Screw Holding Table Insert
- Extension Table and Long Rails enable 50" Rip Capacity
- Sturdy Steel Legs with Adjustable Feet
- Included 10" x 40T Carbide-Tipped Blade



SECTION 1: SAFETY

For Your Own Safety, Read Instruction Manual Before Operating This Machine

The purpose of safety symbols is to attract your attention to possible hazardous conditions. This manual uses a series of symbols and signal words intended to convey the level of importance of the safety messages. The progression of symbols is described below. Remember that safety messages by themselves do not eliminate danger and are not a substitute for proper accident prevention measures. Always use common sense and good judgment.

 **DANGER** Indicates an imminently hazardous situation which, if not avoided, **WILL** result in death or serious injury.

 **WARNING** Indicates a potentially hazardous situation which, if not avoided, **COULD** result in death or serious injury.

 **CAUTION** Indicates a potentially hazardous situation which, if not avoided, **MAY** result in minor or moderate injury. It may also be used to alert against unsafe practices.

NOTICE This symbol is used to alert the user to useful information about proper operation of the machine.

Safety Instructions for Machinery

WARNING

OWNER'S MANUAL. Read and understand this owner's manual **BEFORE** using machine.

TRAINED OPERATORS ONLY. Untrained operators have a higher risk of being hurt or killed. Only allow trained/supervised people to use this machine. When machine is not being used, disconnect power, remove switch keys, or lock-out machine to prevent unauthorized use—especially around children. Make your workshop kid proof!

DANGEROUS ENVIRONMENTS. Do not use machinery in areas that are wet, cluttered, or have poor lighting. Operating machinery in these areas greatly increases the risk of accidents and injury.

MENTAL ALERTNESS REQUIRED. Full mental alertness is required for safe operation of machinery. Never operate under the influence of drugs or alcohol, when tired, or when distracted.

ELECTRICAL EQUIPMENT INJURY RISKS. You can be shocked, burned, or killed by touching live electrical components or improperly grounded machinery. To reduce this risk, only allow qualified service personnel to do electrical installation or repair work, and always disconnect power before accessing or exposing electrical equipment.

DISCONNECT POWER FIRST. Always disconnect machine from power supply **BEFORE** making adjustments, changing tooling, or servicing machine. This prevents an injury risk from unintended startup or contact with live electrical components.

EYE PROTECTION. Always wear ANSI-approved safety glasses or a face shield when operating or observing machinery to reduce the risk of eye injury or blindness from flying particles. Everyday eyeglasses are **NOT** approved safety glasses.



WARNING

WEARING PROPER APPAREL. Do not wear clothing, apparel or jewelry that can become entangled in moving parts. Always tie back or cover long hair. Wear non-slip footwear to reduce risk of slipping and losing control or accidentally contacting cutting tool or moving parts.

HAZARDOUS DUST. Dust created by machinery operations may cause cancer, birth defects, or long-term respiratory damage. Be aware of dust hazards associated with each workpiece material. Always wear a NIOSH-approved respirator to reduce your risk.

HEARING PROTECTION. Always wear hearing protection when operating or observing loud machinery. Extended exposure to this noise without hearing protection can cause permanent hearing loss.

REMOVE ADJUSTING TOOLS. Tools left on machinery can become dangerous projectiles upon startup. Never leave chuck keys, wrenches, or any other tools on machine. Always verify removal before starting!

USE CORRECT TOOL FOR THE JOB. Only use this tool for its intended purpose—do not force it or an attachment to do a job for which it was not designed. Never make unapproved modifications—modifying tool or using it differently than intended may result in malfunction or mechanical failure that can lead to personal injury or death!

AWKWARD POSITIONS. Keep proper footing and balance at all times when operating machine. Do not overreach! Avoid awkward hand positions that make workpiece control difficult or increase the risk of accidental injury.

CHILDREN & BYSTANDERS. Keep children and bystanders at a safe distance from the work area. Stop using machine if they become a distraction.

GUARDS & COVERS. Guards and covers reduce accidental contact with moving parts or flying debris. Make sure they are properly installed, undamaged, and working correctly **BEFORE** operating machine.

FORCING MACHINERY. Do not force machine. It will do the job safer and better at the rate for which it was designed.

NEVER STAND ON MACHINE. Serious injury may occur if machine is tipped or if the cutting tool is unintentionally contacted.

STABLE MACHINE. Unexpected movement during operation greatly increases risk of injury or loss of control. Before starting, verify machine is stable and mobile base (if used) is locked.

USE RECOMMENDED ACCESSORIES. Consult this owner's manual or the manufacturer for recommended accessories. Using improper accessories will increase the risk of serious injury.

UNATTENDED OPERATION. To reduce the risk of accidental injury, turn machine **OFF** and ensure all moving parts completely stop before walking away. Never leave machine running while unattended.

MAINTAIN WITH CARE. Follow all maintenance instructions and lubrication schedules to keep machine in good working condition. A machine that is improperly maintained could malfunction, leading to serious personal injury or death.

DAMAGED PARTS. Regularly inspect machine for damaged, loose, or mis-adjusted parts—or any condition that could affect safe operation. Immediately repair/replace **BEFORE** operating machine. For your own safety, **DO NOT** operate machine with damaged parts!

MAINTAIN POWER CORDS. When disconnecting cord-connected machines from power, grab and pull the plug—**NOT** the cord. Pulling the cord may damage the wires inside. Do not handle cord/plug with wet hands. Avoid cord damage by keeping it away from heated surfaces, high traffic areas, harsh chemicals, and wet/damp locations.

EXPERIENCING DIFFICULTIES. If at any time you experience difficulties performing the intended operation, stop using the machine! Contact our Technical Support at (570) 546-9663.



Additional Safety for Table Saws

WARNING

Serious cuts, amputation, or death can occur from contact with rotating saw blade during operation. Workpieces, broken blades, or flying particles thrown by blade can blind or strike operators or bystanders with deadly force. To reduce the risk of these hazards, operator and bystanders MUST completely heed the hazards and warnings below.

HAND & BODY POSITIONING. Keep hands away from saw blade and out of blade path during operation, so they cannot accidentally slip into blade. Only operate at front of machine and always stand to side of blade path. Never reach behind or over blade.

BLADE GUARD. The blade guard protects operator from rotating saw blade. Make sure blade guard is installed, adjusted correctly, and used for all possible “through cuts.” Promptly repair or replace if damaged. Re-install immediately after operations that require its removal.

RIVING KNIFE. Use riving knife for all “non-through cuts.” Make sure it is aligned and positioned correctly. Promptly repair or replace it if damaged.

KICKBACK. Kickback occurs when saw blade ejects workpiece back toward operator. Know how to reduce risk of kickback, and learn how to protect yourself if it does occur.

FEEDING WORKPIECE. Feeding workpiece incorrectly increases risk of kickback. Always allow blade to reach full speed before cutting, feed workpiece from front of saw, making sure workpiece is flat against table and a fence, miter gauge, or other guide is used to feed workpiece in a straight line. Feed cuts through to completion. Never start saw with workpiece touching blade or pull workpiece from behind blade. Never back workpiece out of cut, move it sideways, or perform a “freehand” operation. Never plunge cut.

PUSH STICKS/PUSH BLOCKS. To reduce risk of accidental blade contact, use push sticks/push blocks whenever possible. In event of an accident, these will often take damage that would have occurred to hands/fingers.

FENCE. To reduce risk of kickback, make sure fence remains properly adjusted and parallel with blade. Always lock fence before using.

CUT-OFF PIECES. To avoid risk of injury due to blade contact, turn saw **OFF** and allow blade to completely stop before removing cut-off pieces near blade or trapped between blade and table insert. Never use your hands to move cut-off pieces away from blade while saw is running.

BLADE ADJUSTMENTS. Adjusting blade height or tilt during operation increases risk of crashing blade and sending metal fragments flying with deadly force at operator or bystanders. Only adjust blade height and tilt when blade is completely stopped and saw is **OFF**.

CHANGING BLADES. Accidental startup while changing saw blade can result in serious injury. To reduce risk of accidental blade contact, always disconnect power before changing blades.

DAMAGED SAW BLADES. Damaged saw blade teeth can become deadly projectiles. Never use blades that have been dropped or damaged.

DADO AND RABBET OPERATIONS. Dado and rabbeting operations require special attention since they must be performed with blade guard removed, which increases risk of blade contact. DO NOT attempt dado or rabbeting operations without first reading these sections in this manual.

CUTTING CORRECT MATERIAL. Cutting metal, glass, stone, tile, etc., increases risk of operator injury due to kickback or flying particles. Only cut natural and man-made wood products, laminate-covered wood products, and some plastics. Never cut materials not intended for this saw.



Preventing Kickback

Below are ways to avoid the most common causes of kickback:

- Only cut workpieces with at least one smooth and straight edge. DO NOT cut warped, cupped or twisted wood.
- Keep the blade guard installed and working correctly for all through cuts.
- Never attempt freehand cuts. If the workpiece is not fed parallel with the blade, kickback will likely occur. Always use the rip fence or miter gauge to support the workpiece.
- Make sure the spreader or riving knife is aligned with the blade. A misaligned spreader or riving knife can cause the workpiece to catch or bind, increasing the chance of kickback.
- Take the time to check and adjust the rip fence parallel with the blade; otherwise, the chances of kickback are extreme.
- The spreader or riving knife maintains the kerf in the workpiece, reducing the chance of kickback. Always use the riving knife for all non-through operations, unless a dado blade is installed. Always use the spreader with the blade guard for all through cuts.
- Feed cuts through to completion. Anytime you stop feeding a workpiece in the middle of a cut, the chance of kickback is greatly increased.
- Keep the blade guard installed and in good working order. Only remove it when performing non-through cuts and immediately re-install the blade guard when finished. Remember, always use the riving knife for all non-through operations, unless a dado blade is installed.
- Make multiple, shallow passes when performing a non-through cut. Making a deep non-through cut will greatly increase the chance of kickback.

- Never move the workpiece backwards or try to back it out of a cut while the blade is moving. If you cannot complete a cut for some reason, stop the saw motor and allow the blade to completely stop before backing the workpiece out. Promptly fix the condition that prevented you from completing the cut before starting the saw again.

Protecting Yourself From Kickback

Even if you know how to prevent kickback, it may still happen. Here are some ways to protect yourself if kickback DOES occur:

- Stand to the side of the blade during every cut. If kickback does occur, the thrown workpiece usually travels directly in front of the blade.
- Wear safety glasses or a face shield. In the event of kickback, your eyes and face are the most vulnerable parts of your body.
- Never, for any reason, place your hand behind the blade. Should kickback occur, your hand will be pulled into the blade, which could cause amputation.
- Use a push stick to keep your hands farther away from the moving blade. If kickback occurs, the push stick will most likely take the damage your hand would have received.
- Use featherboards or anti-kickback devices to assist with feeding and prevent or slow down kickback.

CAUTION

Statistics show that most common accidents among table saw users can be linked to kickback. Kickback is typically defined as the high-speed expulsion of stock from the table saw toward its operator. In addition to the danger of the operator or others in the area being struck by the flying stock, it is often the case that the operator's hands are pulled into the blade during kickback.



Glossary of Terms

The following is a list of common definitions, terms and phrases used throughout this manual as they relate to this table saw and woodworking in general. Become familiar with these terms for assembling, adjusting or operating this machine. Your safety is **VERY** important to us at Grizzly!

Arbor: Rotating metal shaft to which saw blade is mounted that extends from the drive mechanism.

Bevel Edge Cut: Tilting the arbor and saw blade to an angle between 0° and 45° to cut a beveled edge onto a workpiece.

Blade Guard: Metal or plastic safety device that mounts over the saw blade. Its function is to prevent the operator from coming into contact with the saw blade.

Crosscut: Cutting operation in which the fence is used to cut across the grain, or the miter gauge is used to cut across the shortest width of the workpiece.

Dado Blade: Blade or set of blades that are used to cut wide grooves and rabbets.

Dado Cut: "Non-through" cutting operation that uses a dado blade to cut a flat-bottomed groove into the face of the workpiece.

Featherboard: Safety device used to keep the workpiece against the rip fence and table surface.

Kerf: The resulting cut or gap in the workpiece after the saw blade passes through during a cutting operation.

Kickback: An event in which the workpiece is propelled back towards the operator at a high rate of speed.

Non-Through Cut: A cut in which the blade does not cut through the top of the workpiece. Refer to **Page 33** for more details.

Parallel: Being an equal distance apart at every point along two given lines or planes. I.e. the rip fence face is parallel to the face of the saw blade.

Perpendicular: Lines or planes that intersect and form right angles. I.e. the blade is perpendicular to the table surface.

Push Stick: Safety device used to push the workpiece through a cutting operation. Used most often when rip cutting thin workpieces.

Rabbet: Cutting operation that creates an L-shaped channel along the edge of the workpiece.

Rip Cut: Cutting operation in which the rip fence is used to cut with the grain, or across the widest width of the workpiece.

Riving Knife: Metal plate located behind the blade. It maintains the kerf opening in the wood when performing a cutting operation. Refer to **Page 39** for more details.

Straightedge: A tool used to check the flatness, parallelism, or consistency of a surface(s).

Through Cut: A sawing operation in which the workpiece is completely sawn through.



SECTION 2: POWER SUPPLY

Availability

Before installing the machine, consider the availability and proximity of the required power supply circuit. If an existing circuit does not meet the requirements for this machine, a new circuit must be installed. To minimize the risk of electrocution, fire, or equipment damage, installation work and electrical wiring must be done by an electrician or qualified service personnel in accordance with all applicable codes and standards.

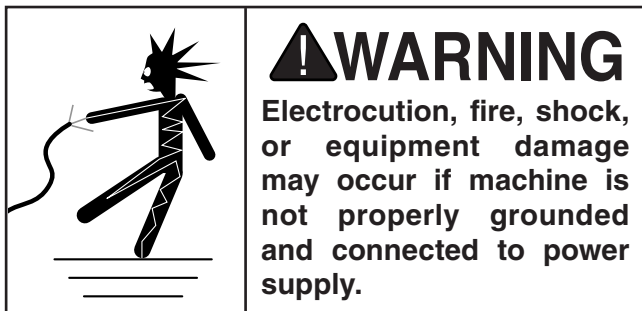

Full-Load Current Rating

The full-load current rating is the amperage a machine draws at 100% of the rated output power. On machines with multiple motors, this is the amperage drawn by the largest motor or sum of all motors and electrical devices that might operate at one time during normal operations.

Full-Load Current Rating at 220V .. 12.8 Amps

The full-load current is not the maximum amount of amps that the machine will draw. If the machine is overloaded, it will draw additional amps beyond the full-load rating.

If the machine is overloaded for a sufficient length of time, damage, overheating, or fire may result—especially if connected to an undersized circuit. To reduce the risk of these hazards, avoid overloading the machine during operation and make sure it is connected to a power supply circuit that meets the specified circuit requirements.

Circuit Information

A power supply circuit includes all electrical equipment between the breaker box or fuse panel in the building and the machine. The power supply circuit used for this machine must be sized to safely handle the full-load current drawn from the machine for an extended period of time. (If this machine is connected to a circuit protected by fuses, use a time delay fuse marked D.)

! CAUTION
For your own safety and protection of property, consult an electrician if you are unsure about wiring practices or electrical codes in your area.

Note: *Circuit requirements in this manual apply to a dedicated circuit—where only one machine will be running on the circuit at a time. If machine will be connected to a shared circuit where multiple machines may be running at the same time, consult an electrician or qualified service personnel to ensure circuit is properly sized for safe operation.*

Circuit Requirements for 220V

This machine is prewired to operate on a power supply circuit that has a verified ground and meets the following requirements:

Nominal Voltage	220V/240V
Cycle	60 Hz
Phase	Single-Phase
Circuit Rating	20 Amps
Plug/Receptacle	NEMA 6-20



Grounding Instructions

This machine **MUST** be grounded. In the event of certain malfunctions or breakdowns, grounding reduces the risk of electric shock by providing a path of least resistance for electric current.

This machine is equipped with a power cord that has an equipment-grounding wire and a grounding plug. Only insert plug into a matching receptacle (outlet) that is properly installed and grounded in accordance with all local codes and ordinances. **DO NOT** modify the provided plug!

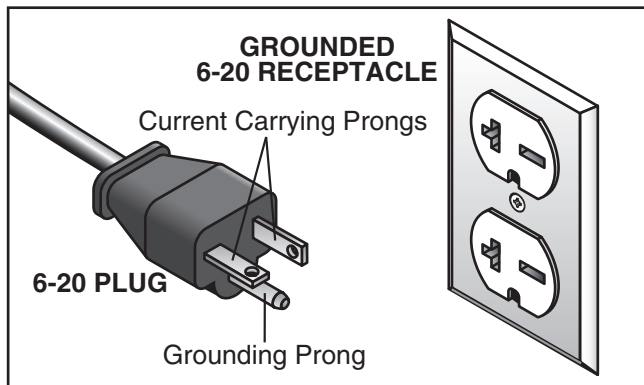
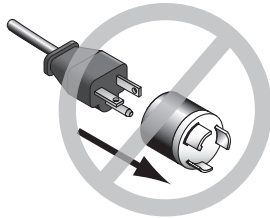

Figure 2. Typical 6-20 plug and receptacle.

⚠ CAUTION



No adapter should be used with plug. If plug does not fit available receptacle, or if machine must be reconnected for use on a different type of circuit, reconnection must be performed by an electrician or qualified service personnel, and it must comply with all local codes and ordinances.

⚠ WARNING

Serious injury could occur if you connect machine to power before completing setup process. DO NOT connect to power until instructed later in this manual.

Improper connection of the equipment-grounding wire can result in a risk of electric shock. The wire with green insulation (with or without yellow stripes) is the equipment-grounding wire. If repair or replacement of the power cord or plug is necessary, do not connect the equipment-grounding wire to a live (current carrying) terminal.

Check with a qualified electrician or service personnel if you do not understand these grounding requirements, or if you are in doubt about whether the tool is properly grounded. If you ever notice that a cord or plug is damaged or worn, disconnect it from power, and immediately replace it with a new one.

Extension Cords

We do not recommend using an extension cord with this machine. If you must use an extension cord, only use it if absolutely necessary and only on a temporary basis.

Extension cords cause voltage drop, which can damage electrical components and shorten motor life. Voltage drop increases as the extension cord size gets longer and the gauge size gets smaller (higher gauge numbers indicate smaller sizes).

Any extension cord used with this machine must be in good condition and contain a ground wire and matching plug/receptacle. Additionally, it must meet the following size requirements:

Minimum Gauge Size 12 AWG
Maximum Length (Shorter is Better)..... 50 ft.



SECTION 3: SETUP

Items Needed for Setup

The following items are needed to complete the setup process, but are not included with your machine:

Description	Qty
• Safety Glasses for Each Person	1
• Degreaser or Solvent for Cleaning	Varies
• Disposable Rags for Cleaning	Varies
• Straightedge	1
• Level	1
• Dust Collection System	1
• 4" Dust Hose	1
• 4" Hose Clamp	1
• Assistant for Lifting	1
• Needle Nose Pliers	1
• Wrench or Socket 17mm	1
• Wrenches or Sockets 13mm	2
• Wrench or Socket 10mm	1
• Wrench 14mm	1
• Adjustable Wrench	1

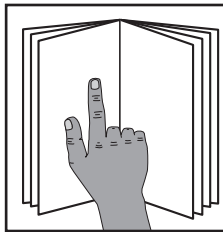

!WARNING

To reduce your risk of serious injury, read this entire manual **BEFORE** using machine.

Unpacking

This machine was carefully packaged for safe transport. When unpacking, separate all enclosed items from packaging materials and inspect them for shipping damage. ***If items are damaged, please call us immediately at (570) 546-9663.***

IMPORTANT: Save all packaging materials until you are completely satisfied with the machine and have resolved any issues between Grizzly or the shipping agent. *You MUST have the original packaging to file a freight claim. It is also extremely helpful if you need to return your machine later.*

<h3>!WARNING</h3> <p>Lifting heavy machinery or parts without proper assistance or equipment may result in strains, back injuries, crushing injuries, or property damage.</p>	



Hardware Recognition Chart

USE THIS CHART TO MATCH UP HARDWARE DURING THE ASSEMBLY PROCESS.

MEASURE BOLT DIAMETER BY PLACING INSIDE CIRCLE

- #10
- 1/4"
- 5/16"
- 3/8"
- 7/16"
- 1/2"

- 4mm
- 5mm
- 6mm
- 8mm
- 10mm
- 12mm
- 16mm

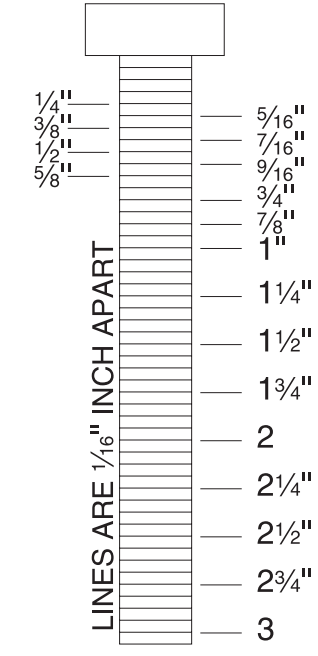
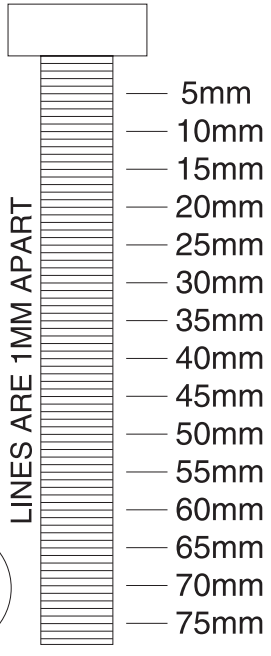
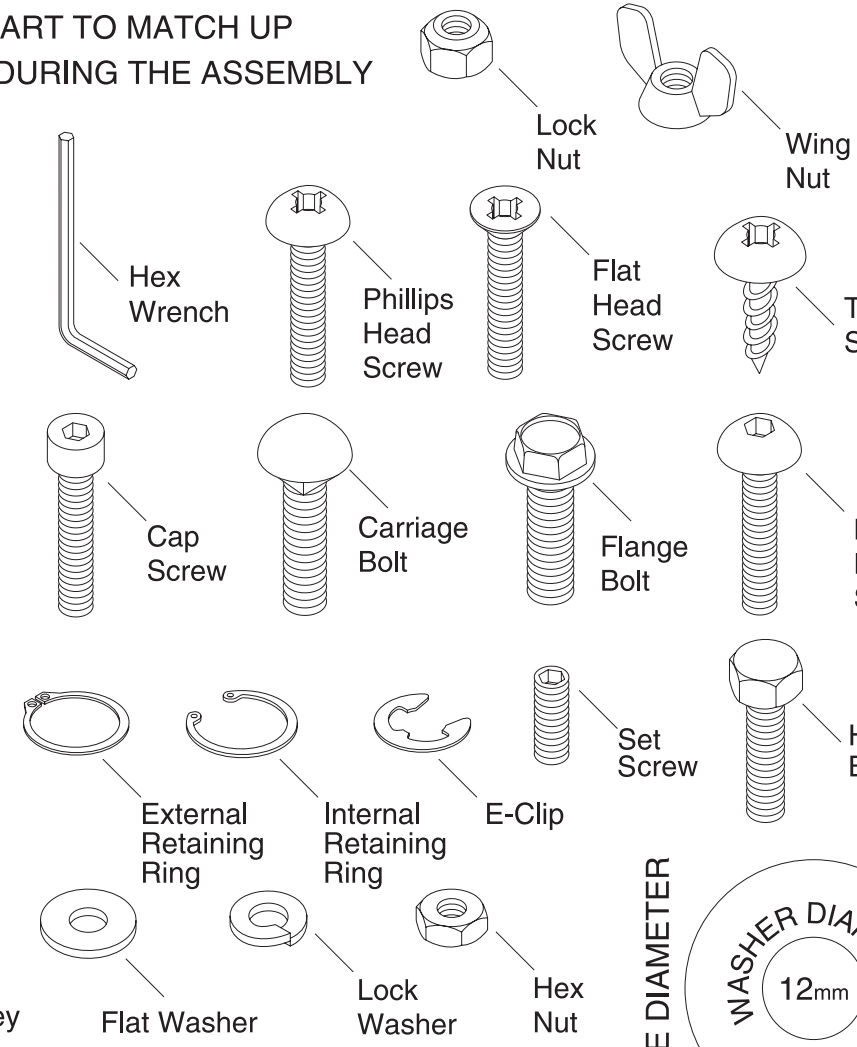

WASHERS ARE MEASURED BY THE INSIDE DIAMETER

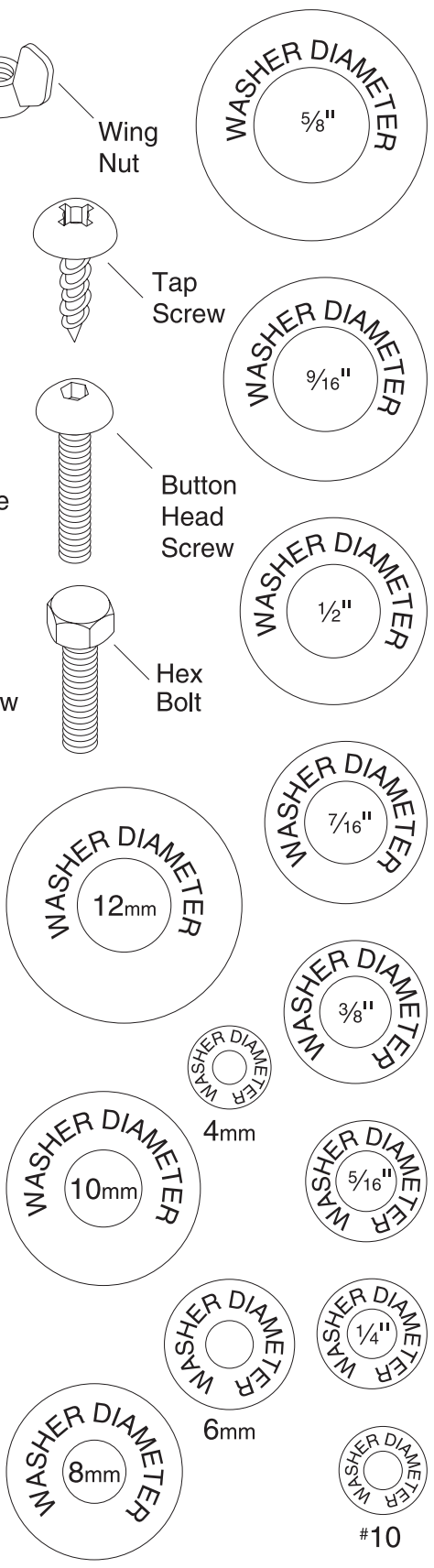

Inventory

The following is a list of items shipped with your machine. Before beginning setup, lay these items out and inventory them.

If any non-proprietary parts are missing (e.g. a nut or a washer), we will gladly replace them; or for the sake of expediency, replacements can be obtained at your local hardware store.

Box Contents: (Figures 3–5)	Qty
A. Main Table Saw Unit	1
B. Extension Wings	2
C. Dust Port	1
D. Door.....	1
E. Blade Guard Assembly	1
F. Riving Knife	1
G. Miter Gauge.....	1
H. Wrench Open-End 27mm.....	1
I. Wrench Open-Ends 22/24mm.....	1
J. Dado Table Insert.....	1
K. Hex Wrench Set (Eight Pieces) 1.5–8mm..	1
L. Key 5 x 5 x 40	1
M. Handwheel Lock Knob	2
N. Handwheel Handle	2
O. Handwheel	2
P. Push Stick	1
Q. Saw Blade 10" x 40T	1

Hardware (Not Shown)	Qty
Phillips Head Screw M6-1 x 12 (Mag Switch)....	1
Hex Bolts M6-1 x 12 (Mag Switch)	2
Lock Washers 6mm (Mag Switch).....	3
Flat Washers 6mm (Mag Switch)	3

NOTICE

If you cannot find an item on this list, carefully check around/inside the machine and packaging materials. Often, these items get lost in packaging materials while unpacking or they are pre-installed at the factory.



Figure 3. Main table saw unit.

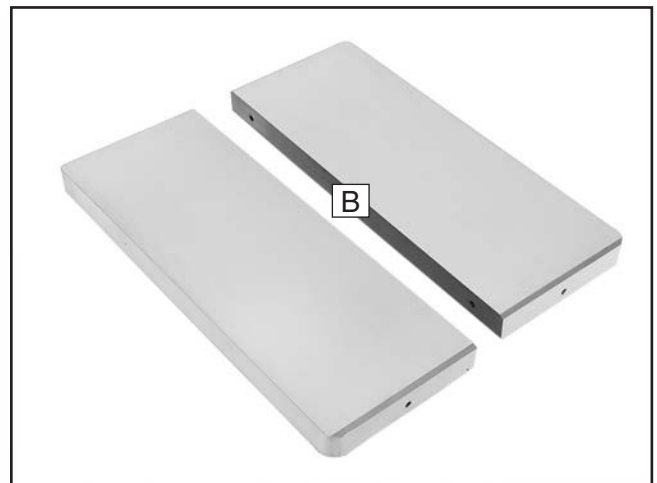

Figure 4. Extension wings.

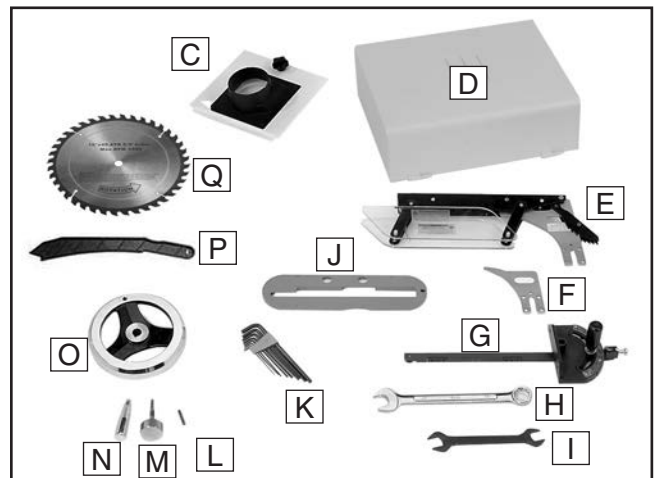

Figure 5. Component inventory.



Fence Inventory G0690

Components	Qty
A. Front Rail Rectangular Tube 62"	1
B. Front Rail Tape Scale.....	1
C. Front Rail 50".....	1
D. Rear Rail 50"	1
E. Fence Assembly.....	1
F. Fence Handle	1
G. Rear Rail Foot M12-1.75	1
H. Hex Wrench 6mm.....	1
I. Extension Table 27" x 13 ³ / ₄ "	1

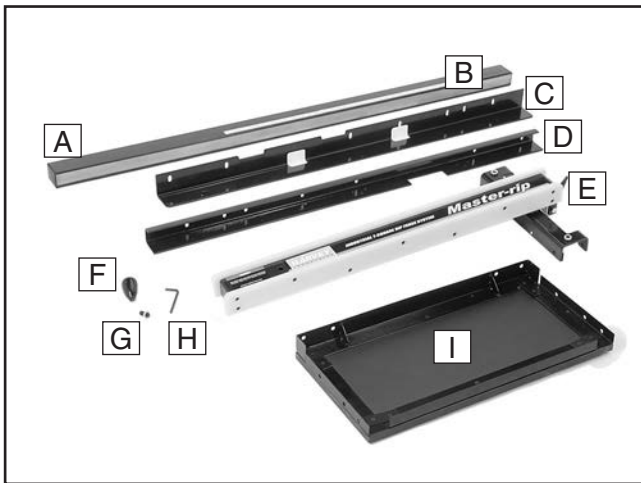

Figure 6. Inventory needed to install the fence on the Model G0690.

Hardware and Tools (Not Shown)	Qty
Cap Screws M6-1 x 16 (Front Rail/Tube)	3
Flat Washers 6mm (Front Rail/Tube)	3
Lock Washers (Front Rail/Tube).....	3
Hex Bolts M8-1.25 x 40 (Front & Rear Rails)	6
Flat Washers 8mm (Front & Rear Rails)	14
Lock Washers 8mm (Front & Rear Rails).....	8
Hex Nuts M8-1.25 (Front & Rear Rails).....	6
Hex Bolts 5/16"-18 x 1" (Rear Rail)	2
Hex Bolts M8-1.25 x 30 (Extension Table)	4
Hex Nuts M8-1.25 (Extension Table).....	4
Flat Washers 8mm (Extension Table)	8
Lock Washers 8mm (Extension Table).....	4

Fence Inventory G0691

Components	Qty
A. Front Rail Rectangular Tube 82"	1
B. Front Rail 70".....	1
C. Rear Rail 70"	1
D. Fence Assembly.....	1
D. Fence Handle	1
F. Rear Rail Foot	1
G. Hex Wrench 6mm.....	1
H. Front Rail Tape Scale.....	1
I. Extension Table.....	1
J. Legs.....	2

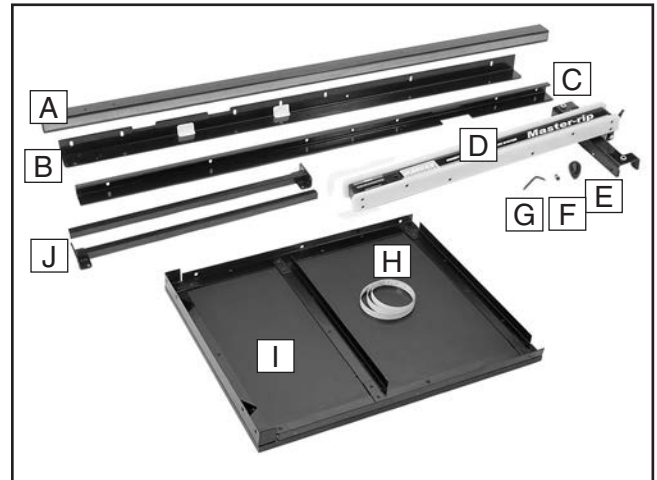

Figure 7. Inventory needed to install the fence on the Model G0691.

Hardware and Tools (Not Shown)	Qty
Feet w/Bolts & Hex Nuts	2 Sets
Cap Screws M6-1 x 16 (Front Rail/Tube)	5
Flat Washers 6mm (Front Rail/Tube)	5
Lock Washers (Front Rail/Tube).....	5
Hex Bolts M8-1.25 x 40 (Front & Rear Rails)	6
Flat Washers 8mm (Front & Rear Rails)	14
Lock Washers 8mm (Front & Rear Rails).....	8
Hex Nuts M8-1.25 (Front & Rear Rails).....	6
Hex Bolts 5/16"-18 x 1" (Rear Rail)	2
Hex Bolts M8-1.25 x 30 (Extension Table)	6
Hex Nuts M8-1.25 (Extension Table).....	6
Flat Washers 8mm (Extension Table)	12
Lock Washers 8mm (Extension Table).....	6
Cap Screws M8-1.25 x 20 (Legs)	4
Flat Washers 8mm (Legs)	4
Lock Washers 8mm (Legs)	4
Hex Nuts M8-1.25 (Legs).....	4



Cleanup

The unpainted surfaces of your machine are coated with a heavy-duty rust preventative that prevents corrosion during shipment and storage. This rust preventative works extremely well, but it will take a little time to clean.

Be patient and do a thorough job cleaning your machine. The time you spend doing this now will give you a better appreciation for the proper care of your machine's unpainted surfaces.

There are many ways to remove this rust preventative, but the following steps work well in a wide variety of situations. Always follow the manufacturer's instructions with any cleaning product you use and make sure you work in a well-ventilated area to minimize exposure to toxic fumes.

Before cleaning, gather the following:

- Disposable rags
- Cleaner/degreaser (WD-40 works well)
- Safety glasses & disposable gloves
- Plastic paint scraper (optional)

Basic steps for removing rust preventative:

1. Put on safety glasses.
2. Coat the rust preventative with a liberal amount of cleaner/degreaser, then let it soak for 5–10 minutes.
3. Wipe off the surfaces. If your cleaner/degreaser is effective, the rust preventative will wipe off easily. If you have a plastic paint scraper, scrape off as much as you can first, then wipe off the rest with the rag.
4. Repeat **Steps 2–3** as necessary until clean, then coat all unpainted surfaces with a quality metal protectant to prevent rust.

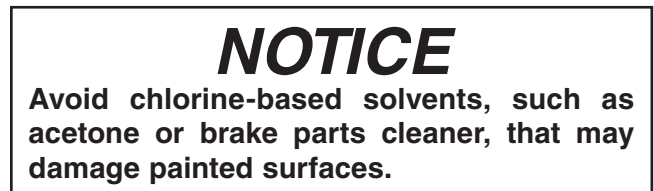
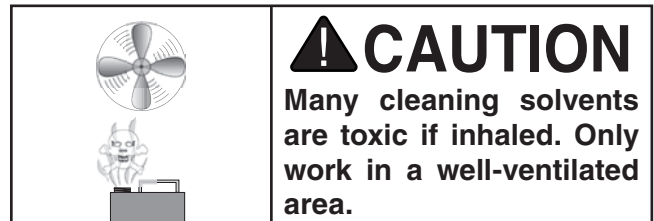
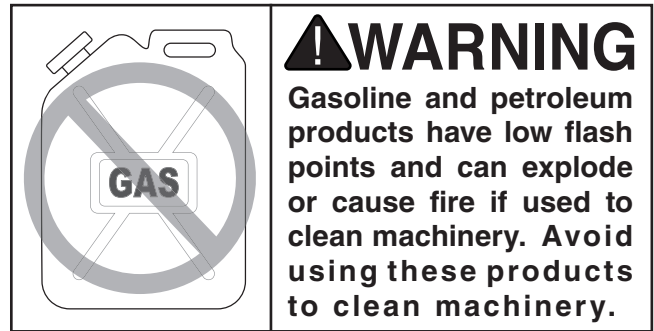

T23692—Orange Power Degreaser

A great product for removing the waxy shipping grease from the **non-painted** parts of the machine during clean up.



Figure 8. T23692 Orange Power Degreaser.



Site Considerations

Weight Load

Refer to the **Machine Data Sheet** for the weight of your machine. Make sure that the surface upon which the machine is placed will bear the weight of the machine, additional equipment that may be installed on the machine, and the heaviest workpiece that will be used. Additionally, consider the weight of the operator and any dynamic loading that may occur when operating the machine.

Space Allocation

Consider the largest size of workpiece that will be processed through this machine and provide enough space around the machine for adequate operator material handling or the installation of auxiliary equipment. With permanent installations, leave enough space around the machine to open or remove doors/covers as required by the maintenance and service described in this manual. **See below for required space allocation.**

Physical Environment

The physical environment where the machine is operated is important for safe operation and longevity of machine components. For best results, operate this machine in a dry environment that is free from excessive moisture, hazardous chemicals, airborne abrasives, or extreme conditions. Extreme conditions for this type of machinery are generally those where the ambient temperature range exceeds 41°–104°F; the relative humidity range exceeds 20%–95% (non-condensing); or the environment is subject to vibration, shocks, or bumps.

Electrical Installation

Place this machine near an existing power source. Make sure all power cords are protected from traffic, material handling, moisture, chemicals, or other hazards. Make sure to leave enough space around machine to disconnect power supply or apply a lockout/tagout device, if required.

Lighting

Lighting around the machine must be adequate enough that operations can be performed safely. Shadows, glare, or strobe effects that may distract or impede the operator must be eliminated.

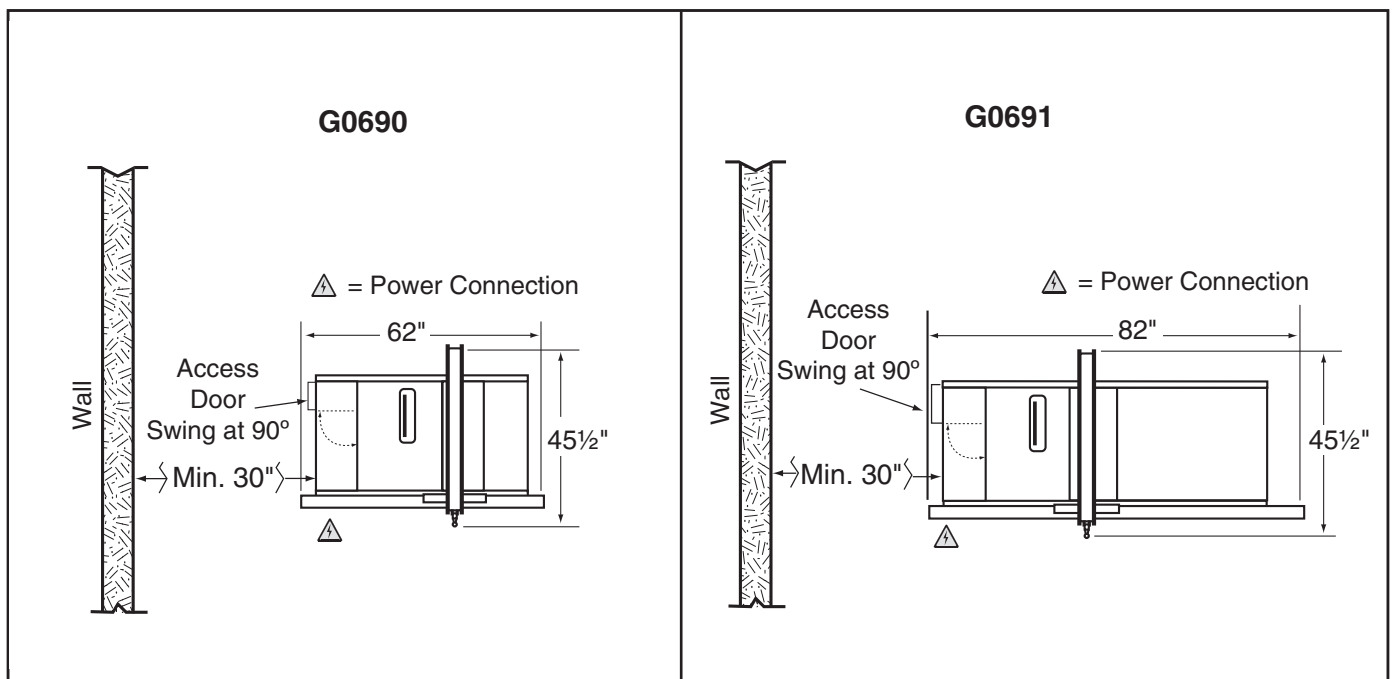

Figure 9. Minimum working clearances.



Assembly

Assembly steps are the same for the Model G0690 and G0691 except where noted. Assembly consists of installing minor components, the extension wings, front and rear rails, extension table, and the legs (Model G0691 only).

To assemble the table saw:

1. Pull the magnetic switch out of the saw cabinet and install the door by inserting the door pins into the hinge sockets on the cabinet (see **Figure 10**).



Figure 10. Door installed.

2. Place the included 5 x 5 x 40 key in the handwheel shaft and slide the handwheel onto the shaft on the front of the table saw. Use the included 2.5mm hex wrench to tighten the set screw (see **Figure 11**) on the side of the handwheel until it is secure.



Figure 11. Handwheel set screw.

3. Thread the handwheel lock knob into the center of the handwheel and tighten, then install the handle into the handwheel using a 14mm wrench (see **Figure 12**).

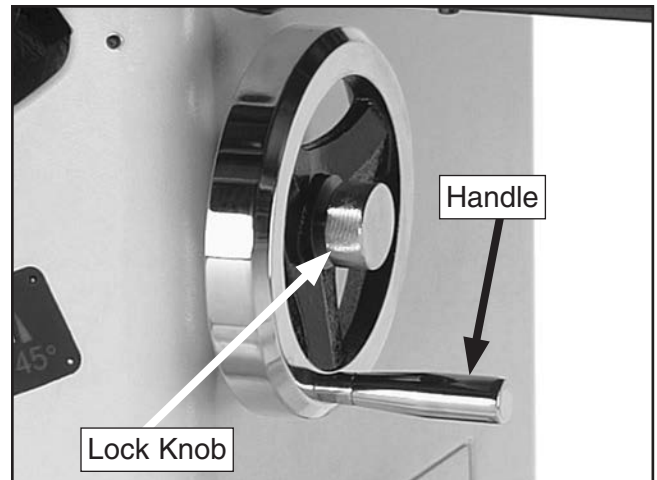

Figure 12. Handwheel installed.

4. Remove the shipping brace (see **Figure 13**) using a 17mm wrench and a pair of needle nose pliers. Reinstall the M10-1.5 x 25 hex bolt, flat washer, hex nut and the cotter pin, and save the shipping brace.



Figure 13. Shipping brace location.



5. Insert the lip of the lower part of the dust port into the cabinet and tighten the thumb knob (already installed) to secure (see **Figure 14**).

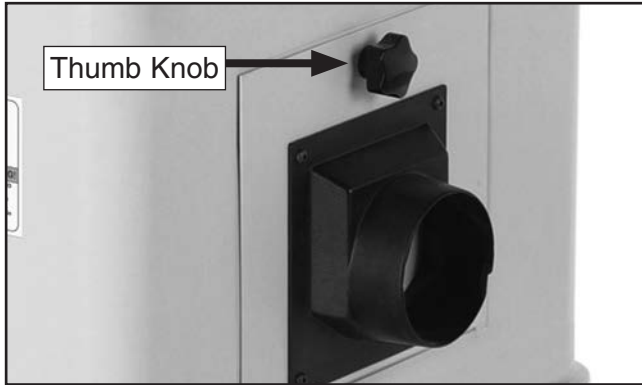

Figure 14. Dust port installed.

6. Remove the M8-1.25 x 30 cap screws, and 8mm flat washers and lock washers from the ends of the main table.
7. Inspect the extension wings and main table mating surfaces for burrs or foreign materials that may inhibit assembly.

The mating edges of the wings and the table must be clean, smooth, and flat. Use a wire brush or file if necessary to clean up the edges. This step will ensure that the wings mount properly to the main table.

8. While a helper holds the wings in place, attach each extension wing to the main table with the (4) M8-1.25 x 30 cap screws, 8mm lock washers, and 8mm flat washers removed in **Step 6** (**Figure 15**).

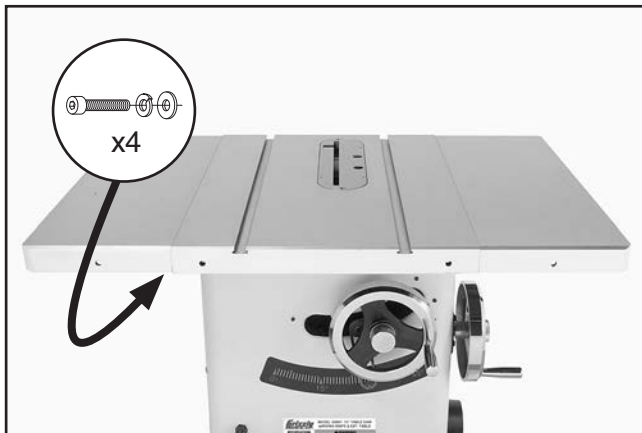

Figure 15. Extension wings installed.

9. Place the straightedge across the extension wings and main table to make sure that the combined table surface is flat.

—If the combined table surface is flat, skip to the next step.

—If the outside end of the extension wing tilts down, use a strip of masking tape along the bottom edge of the main table to shim the extension wing up (**Figure 16**).

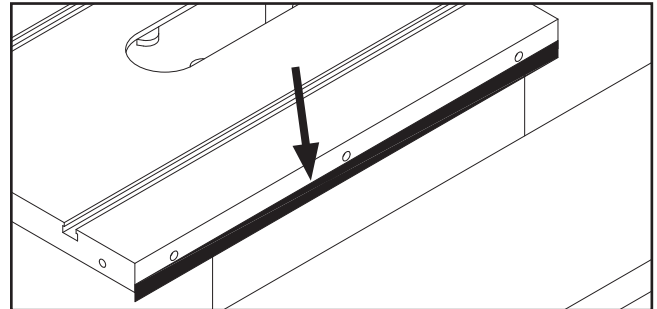

Figure 16. Masking tape location for tilting the extension wing up.

— If the outside end of the extension wing tilts up, use a strip of masking tape along the top edge of the main table to shim the extension wing down (**Figure 17**).

Note: After reinstalling wings, remove all excess masking tape with a razor blade.

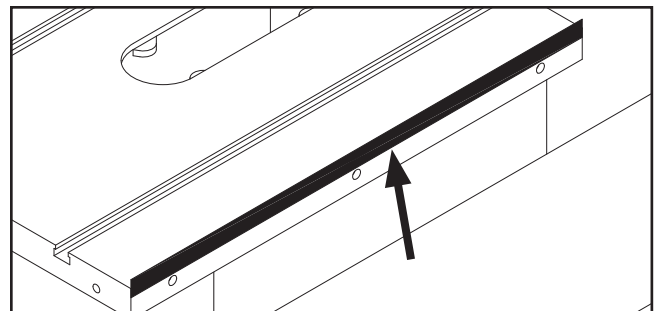

Figure 17. Masking tape location for adjusting the extension wing down.



10. Install the front rail onto the table and extension wings with (4) M8-1.25 x 40 hex bolts, (8) 8mm flat washers, (4) 8mm lock washers, and (4) M8-1.25 hex nuts, as shown in **Figure 18**.

Before final tightening, make sure the front rail is set $\frac{3}{16}$ " below the beveled edge of the main table and extension wings along its entire length.



Figure 18. Front rail installed (Model G0690 shown).

11. **G0690 ONLY:** Install the 62" front rail rectangular tube onto the 50" front rail with (3) M6-1 x 16 cap screws, 6mm flat washers, and 6mm lock washers, as shown in **Figure 19**.



Figure 19. Model G0690 tube attached to front rail.

- G0691 ONLY:** Install the 82" front rail rectangular tube onto the 70" front rail with (5) M6-1 x 16 cap screws, 6mm lock washers, and 6mm flat washers, as shown in **Figure 20**.

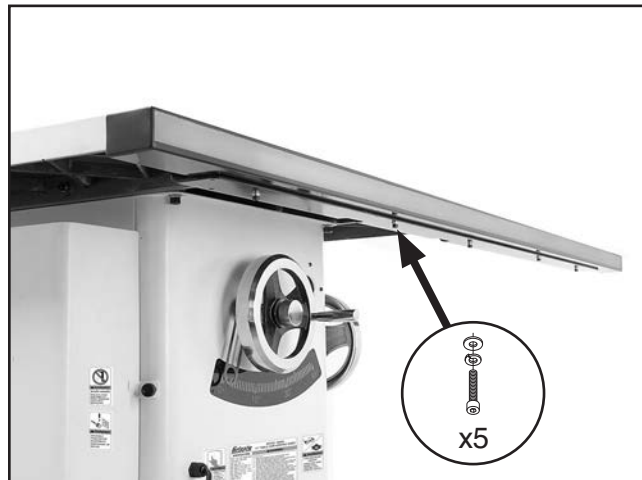

Figure 20. Model G0691 tube attached to front rail.

12. Attach the rear rail to the holes on the main table using (2) $\frac{5}{16}$ "-18 x 1" hex bolts, 8mm lock washers, and 8mm flat washers, as shown in **Figure 21**.

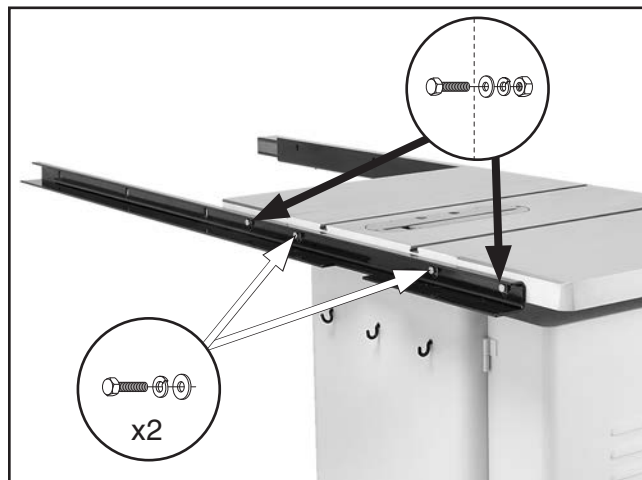

Figure 21. Rear rail installed (Model G0691 shown).

13. Secure the rear rail to the extension wings with (2) M8-1.25 x 40 hex bolts, (4) 8mm flat washers, (2) 8mm lock washers, and (2) M8-1.25 hex nuts.



Note: Before tightening the fasteners, check to make sure the top edge of the rear rail is flush with the lowest edge of both T-slots (see **Figure 22**), so the miter gauge will slide smoothly when installed later.

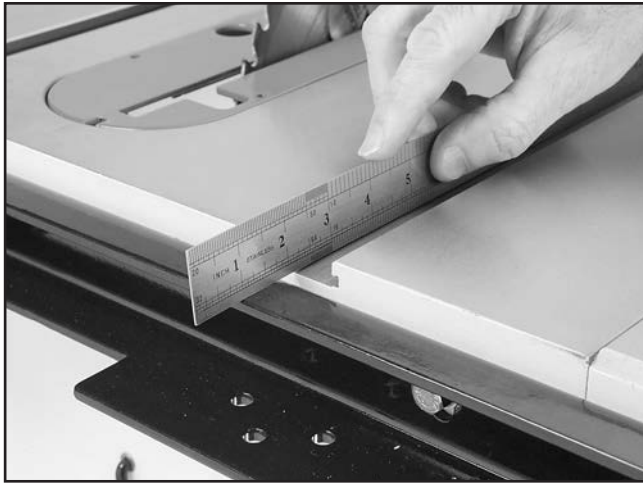

Figure 22. Verifying rear rail is flush with bottom of T-slot.

G0690 Extension Table

1. Install the extension table between the front and rear rails with the (4) M8-1.25 x 30 hex bolts, (8) 8mm flat washers, (4) 8mm lock washers, and (4) M8-1.25 hex nuts, as shown in **Figure 23**.



Figure 23. Model G0690 extension table installed.

2. Using a long straightedge, adjust the extension table so it is flat (both flush and parallel) with the main table and extension wings (**Figure 24**), then tighten the fasteners.



Figure 24. Adjusting Model G0690 extension table flush with extension wing and table.

G0691 Extension Table

1. While an assistant holds the extension table between the front and rear rails, fasten the extension table to the rails with (6) M8-1.25 x 30 hex bolts, (12) 8mm flat washers, (6) 8mm lock washers, and (6) M8-1.25 hex nuts.
2. Thread the feet into the legs with the (2) M8-1.25 x 60 hex bolts, place the legs under the table, and thread the feet out until the top of each leg is against the underside corner of the table.
3. Use the (4) M8-1.25 x 20 cap screws, 8mm lock washers, flat washers, and M8-1.25 hex nuts to secure the legs to the end of the extension table, as shown in **Figure 25**.

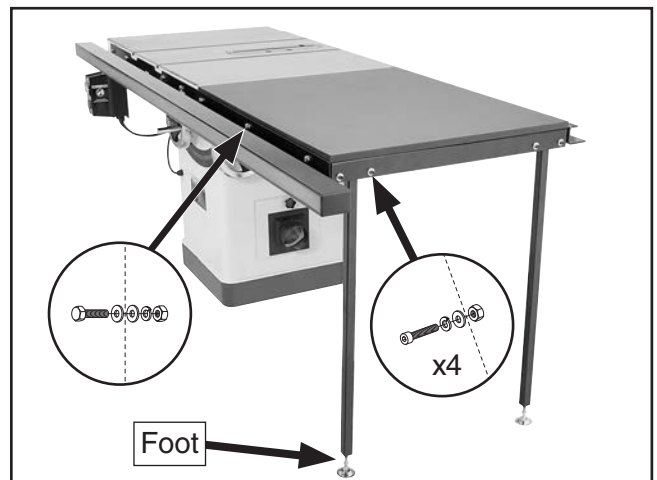

Figure 25. Model G0691 extension table installed.



- Adjust the extension table so it is flat (both flush and parallel) with the main table, using a long straightedge (similar to the method shown in **Figure 24**). This can be done by loosening the mounting bolts and adjusting the feet up/down as needed.
- Tighten the extension table mounting bolts, and tighten the hex nuts on the feet up against the legs so they will not move.

Fence & Miter Gauge

- Attach the fence handle to the fence and thread the rear rail foot into the bottom of the fence (see **Figure 26**).

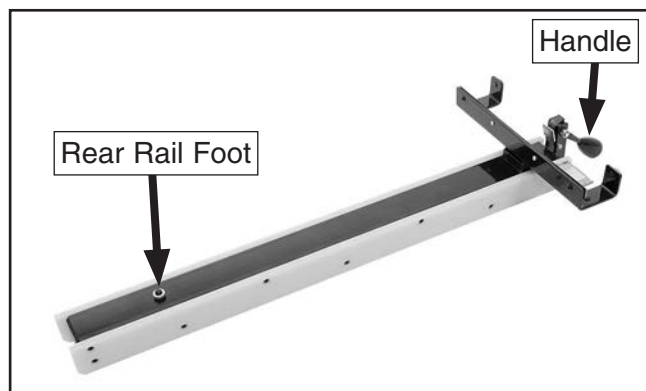

Figure 26. Fence assembled.

- Place the fence on the rails on the right hand side of the blade.

Note: Make sure the cam foot contacts the cam on the fence lock handle before you place the fence on the rail, otherwise the fence will not lock onto the rail tube.

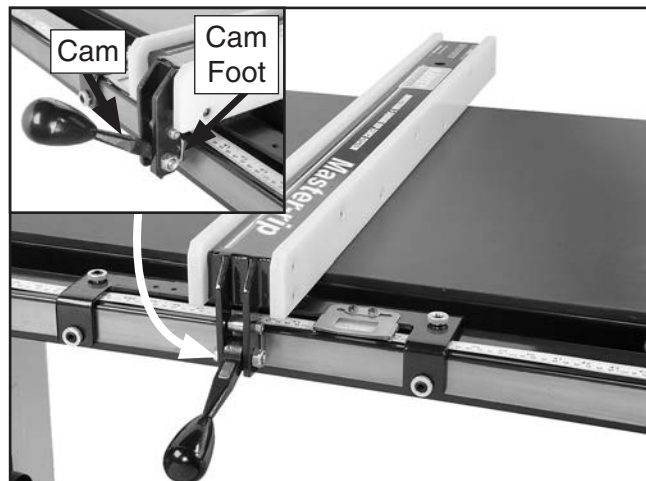

Figure 27. Fence installed on rails.

- Slide the miter gauge into the T-slot on the left hand side of the blade.

Magnetic Switch

- Install the magnetic switch onto the bottom left-hand side of the front rail using (2) M6-1 x 12 hex bolts, 6mm lock washers, and 6mm flat washers, as shown in **Figure 28**.

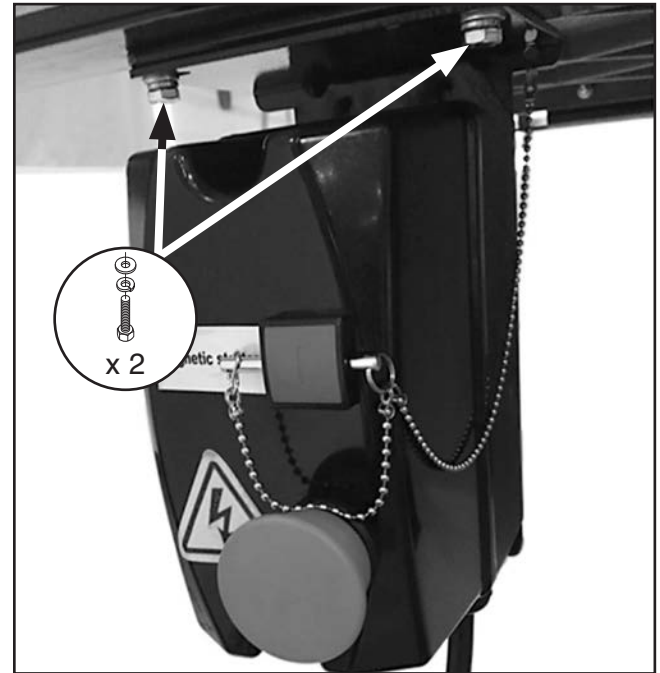

Figure 28. Magnetic switch installed.

- Secure the top of the switch to the rail with an M6-1 x 12 Phillip head screw, 6mm lock washer, and flat washer.

Saw Blade

- Remove the table insert by unscrewing the screw that fastens it to the table.
- Raise the arbor all the way up and set the blade angle at 0°.
- Remove the arbor nut and arbor flange from the arbor, slide on the included 10" saw blade, making sure the teeth face the front of the saw, then install the arbor flange and arbor nut onto the blade.
- Put on a pair of heavy leather gloves and use the included arbor wrenches to tighten the arbor nut (turn clockwise to tighten), as shown in **Figure 29**.





Figure 29. Securing blade.

Checking Fence Parallelism

1. Slide the fence along the rail. If it drags across the table, then adjust the foot at the rear of the fence with a 6mm hex wrench to raise the fence off of the table, just enough so that the gap between the fence and the table is even from front to back.
2. Slide the fence up against the right hand edge of the miter slot, and lock it in place. Examine how the fence lines up with the miter slot.

Note: *It's permissible for the back of the fence to pivot outward no more than 1/64" from being parallel to the blade. This creates a larger opening between the fence and the blade, at the rear of the blade, to reduce the risk of workpiece binding or burning as it is fed through the cut. Many woodworkers intentionally set up their fence in this manner. Keep this in mind before adjusting your fence.*

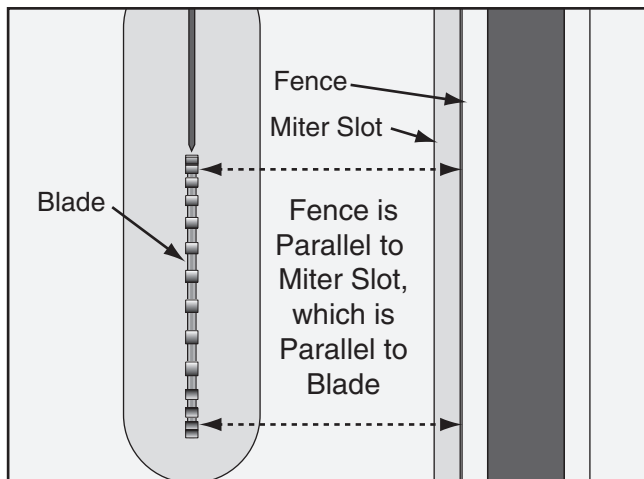

Figure 30. Checking fence parallelism with blade.

- If the fence/miter slot are still parallel with the blade, proceed to **Fence Scale**.
- If the fence is not parallel to the blade/miter slot, then you **MUST** adjust the fence, as described in **Fence Adjustments** on **Page 69**, so that it is parallel to the blade.
- If the miter slot is not parallel with the blade, you must follow the procedures described in **Miter Slot to Blade Parallelism** on **Page 67**.

Fence Scale

Since the adhesive fence scale will be difficult to remove once it is installed, determine whether you will use the pointer window on the right or the left side of the fence before installing the scale.

The pointer window may come pre-installed on the left side of the fence. However, we recommend loosening the mounting screws on the window and reinstalling it on the right side of the fence (see **Figure 31**) so workpieces will not cover the pointer window when preparing to cut.

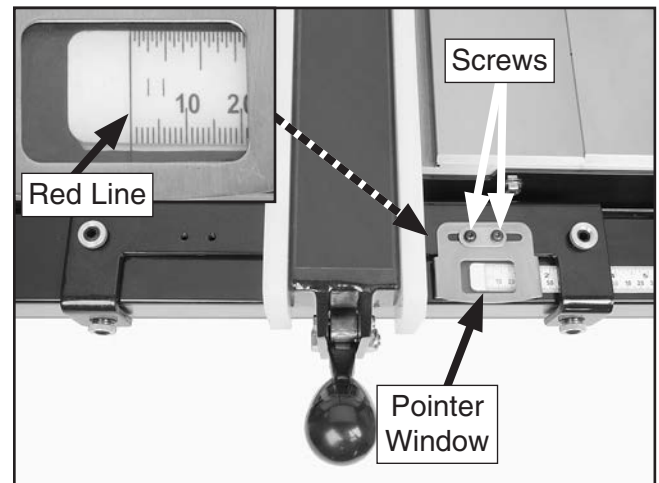

Figure 31. Aligning rail tape with scale pointer.

On the Model G0690, if you move the pointer window to the right side of the fence, you may have to trim the last two inches of the scale so it will not protrude past the end of the fence tube.

One option for using the pointer window on the left side of the fence is to use it in conjunction with a small, left-reading scale (not included).



To install the fence scale:

1. Slide the fence up against the saw blade and lock it in place.
2. Place the front rail tape scale on the fence tube, making sure it is parallel with the tube and that the "0" end is directly under the red line on the pointer window, as shown in **Figure 31**.
3. Lightly mark the "0" location on the fence tube with a pencil, then remove the fence.
4. Peel the tape and carefully align the "0" mark on the scale with the pencil mark you made on the fence tube.

—If you make a mistake, loosen the screws on the pointer window, slide the fence against the blade, adjust the pointer window so the red line on the window is over the 0" mark on the tape, then secure the screws.

Blade Guard

1. Reinstall the table insert, slide the knurled knob out (see **Figure 32**) and rotate it forward so it engages the upper bracket.

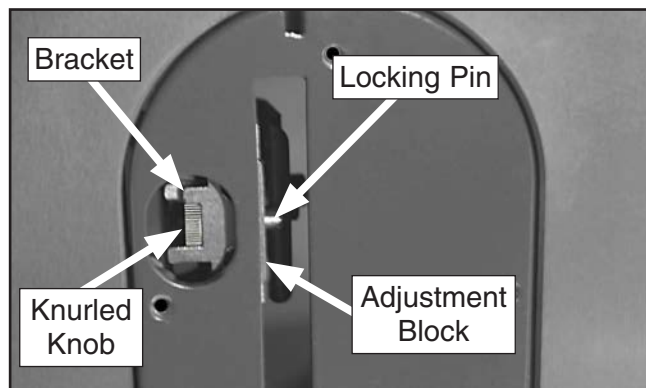

Figure 32. Knurled knob used to secure spreader.

2. Slide the blade guard spreader all the way down into the adjustment block, then rotate the knurled knob so it disengages the bracket and the locking pin engages the hole in the center of the spreader.
3. Give the spreader an upward tug to verify that it is locked.

The blade guard, when properly installed, should look like **Figure 33**, and should pivot freely so it touches the table surface in the down position. It should also swing up high enough to accommodate the workpiece.

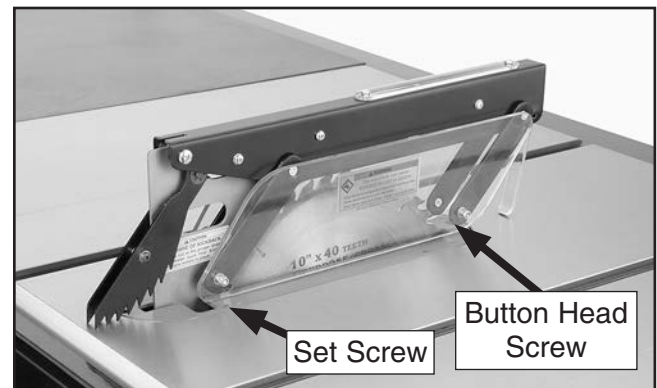

Figure 33. Blade guard installed.

4. Adjust the set screws to make sure the table insert is flush with the table (use a straightedge as a guide), then tighten the button head screw to secure the table insert in place.
5. Place a straightedge against the blade and the spreader. When properly aligned, the spreader/riving knife will be in the "Alignment Zone," shown in **Figure 34**, and will be parallel with the blade.

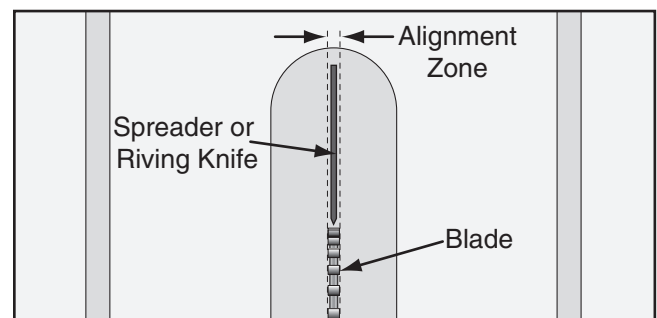

Figure 34. Spreader/riving knife alignment zone.

—If the spreader/riving knife is not inside the alignment zone and not parallel with the blade, then it needs to be adjusted. Proceed to "Adjusting Alignment" on **Page 68**.

—If the spreader/riving knife is not parallel with the blade, it may be bent. Proceed to "Checking Alignment" on **Page 68** to determine if the spreader/riving knife is bent.



Dust Collection

⚠ CAUTION

DO NOT operate the Model G0690 or G0691 without an adequate dust collection system. This saw creates substantial amounts of wood dust while operating. Failure to use a dust collection system can result in short and long-term respiratory illness.

Components and Hardware Needed:	Qty
Dust Hose 4" (not included)	1
Hose Clamps 4" (not included)	2
Dust Collection System (not included)	1

Recommended CFM at Dust Port: 400 CFM

Do not confuse this CFM recommendation with the rating of the dust collector. To determine the CFM at the dust port, you must consider these variables: (1) CFM rating of the dust collector, (2) hose type and length between the dust collector and the machine, (3) number of branches or wyes, and (4) amount of other open lines throughout the system. Explaining how to calculate these variables is beyond the scope of this manual. Consult an expert or purchase a good dust collection "how-to" book.

To connect a dust collection hose:

1. Fit a 4" dust hose over the dust port, as shown in **Figure 35**, and tightly secure in place with a hose clamp.
2. Tug the hose to make sure it does not come off. **Note:** A tight fit is necessary for proper performance.



Figure 35. Dust hose attached to dust port.

Power Connection

After you have completed all previous setup instructions and circuit requirements, the machine is ready to be connected to the power supply.

To avoid unexpected startups or property damage, use the following steps whenever connecting or disconnecting the machine from the power

Connecting Power

1. Turn the machine power switch **OFF**.
2. Insert the power cord plug into a matching power supply receptacle. The machine is now connected to the power source.

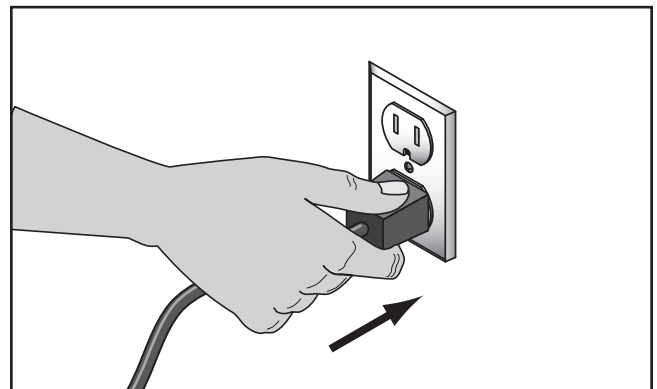

Figure 36. Connecting power.

Disconnecting Power

1. Turn the machine power switch **OFF**.
2. Grasp the molded plug and pull it completely out of the receptacle. **DO NOT** pull by the cord as this may damage the wires inside.

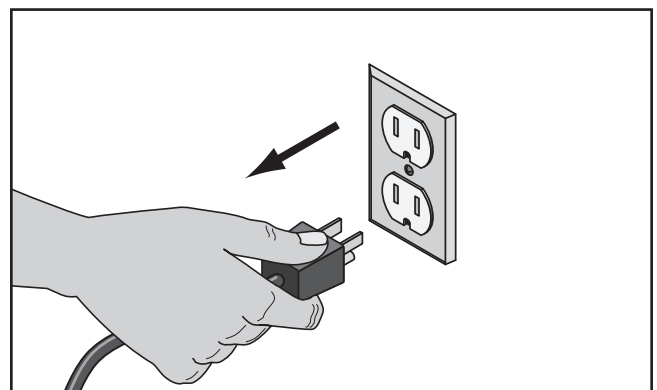

Figure 37. Disconnecting power.



Test Run

Once the assembly is complete, test run your machine to make sure it runs properly and is ready for regular operation.

The test run consists of verifying the following:
1) The motor powers up and runs correctly, and
2) the safety disabling mechanism on the switch works correctly.

If, during the test run, you cannot easily locate the source of an unusual noise or vibration, stop using the machine immediately, then review **Troubleshooting** on **Page 63**.

If you still cannot remedy a problem, contact our Tech Support at (570) 546-9663 for assistance.

To test run the machine:

1. Make sure you have read the safety instructions at the beginning of the manual and that the machine is setup properly.
2. Make sure all tools and objects used during setup are cleared away from the machine.
3. Connect the machine to the power source.
4. Verify that the machine is operating correctly by turning the machine **ON**.
 - When operating correctly, the machine runs smoothly with little or no vibration or rubbing noises.
 - Investigate and correct strange or unusual noises or vibrations before operating the machine further. Always disconnect the machine from power when investigating or correcting potential problems.
5. Turn the machine **OFF**.
6. Insert the switch disabling pin through the green ON button, as shown in **Figure 38**.



Figure 38. Switch disabling pin inserted into ON button.

7. Press the green ON button to test the disabling feature on the switch.
 - If the machine does not start, the switch disabling feature is working as designed.
 - If the machine starts, immediately stop the machine. The switch disabling feature is not working correctly. This safety feature must work properly before proceeding with regular operations. Call Tech Support for help.

Recommended Adjustments

For your convenience, the adjustments listed below have been performed at the factory and no further setup is required to operate your machine. However, because of the many variables involved with shipping, we recommend that you at least verify the following adjustments to ensure that the cutting you do with your new machine is safe and accurate.

Step-by-step instructions for these adjustments can be found in **SECTION 7: SERVICE**.

Adjustments that should be verified:

1. Blade Tilt Stop Accuracy (**Page 65**).
2. Miter Slot Parallel to Blade (**Page 67**).
3. Spreader/Riving Knife Alignment (**Page 68**).



SECTION 4: OPERATIONS

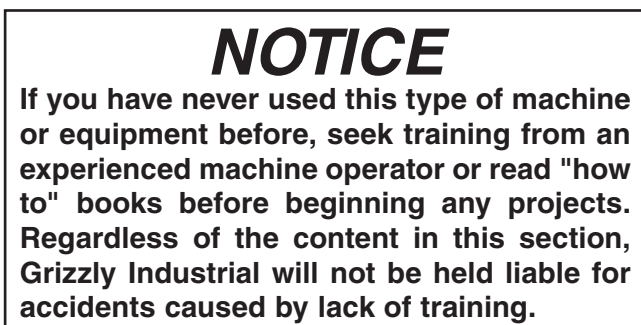
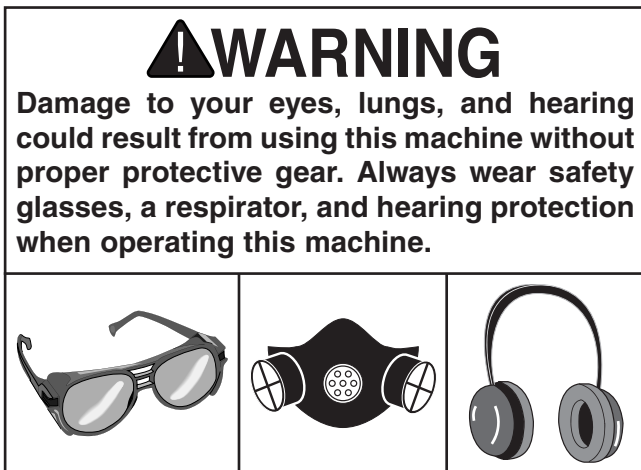
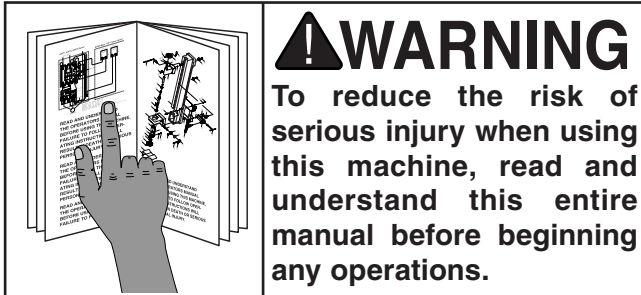

Operation Overview

The purpose of this overview is to provide the novice machine operator with a basic understanding of how the machine is used during a typical operation, so the controls/components discussed later in this manual are easier to understand.

Due to the generic nature of this overview, it is not intended to be an instructional guide. To learn more about specific operations, read this entire manual, read "how to" books, and seek additional training from experienced machine operators.

To complete a typical operation, the operator does the following:

- Examines the workpiece to make sure it is suitable for cutting.
- Adjusts the blade tilt, if necessary, to the correct angle for the desired cut.
- For "Through Cuts," adjusts the blade height no more than $\frac{1}{4}$ " higher than the thickness of the workpiece.
- Adjusts the fence to the desired width of cut, then locks it in place.
- Checks the outfeed side of the machine for proper support and to make sure the workpiece can safely pass all the way through the blade without interference.
- Puts on safety glasses and a respirator. Locates push sticks/blocks if needed.
- Starts the saw.
- Feeds the workpiece all the way through the blade while maintaining firm pressure on the workpiece against the table and fence, and keeping hands and fingers out of the blade path and away from the blade.
- Stops the machine immediately after the cut is complete.



Basic Controls

ON Button: Starts the motor (see **Figure 39**).

Safety Pin & Chain: When installed (see **Figure 39**), disables the ON Button to prevent accidental startup.

Emergency Stop/Reset Button: Turns machine **OFF**. Rotate clockwise to reset. (see **Figure 39**).

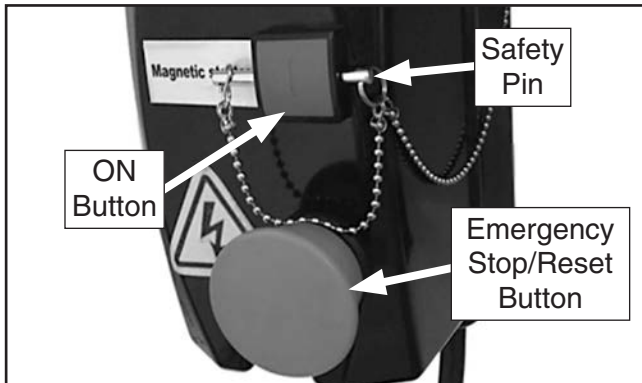

Figure 39. Power controls.

Blade Tilt: To adjust the blade tilt, loosen the blade tilt lock, turn the blade tilt handwheel to position the blade at the desired angle, then tighten the lock shown in **Figure 40**.

Blade Height: To set the blade height, unlock the blade height lock, turn the handwheel to set the blade height approximately $\frac{1}{4}$ " higher than the workpiece, then re-tighten the blade height lock.

Fence Lock: After adjusting the fence to the desired width of cut, lock it in place by firmly pushing the fence lock down until it stops.

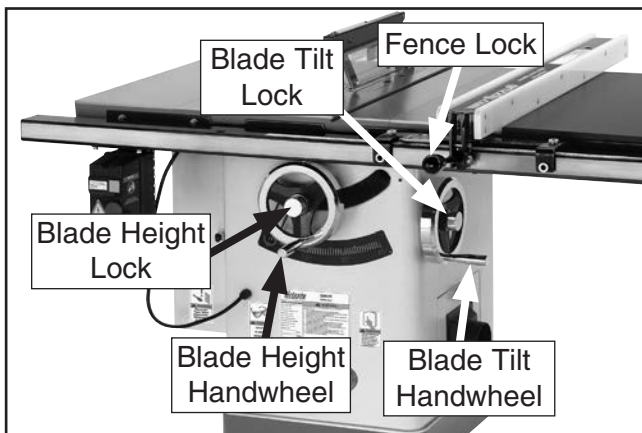

Figure 40. Basic table saw controls.

Non-Through & Through Cuts

Non-Through Cuts

A non-through cut is a sawing operation where the blade does not protrude above the top face of the wood stock, as shown in the **Figure** below.

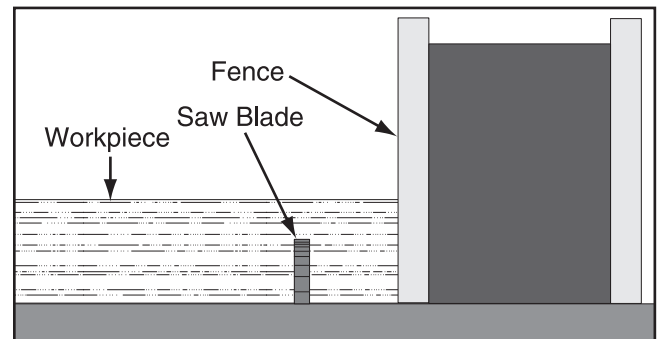

Figure 41. Example of a non-through cut.

Examples of non-through cuts include dadoes and rabbets. Non-through cuts have a higher risk of injury from kickback because the blade guard must be removed. However, the riving knife **MUST** be installed because it still provides some protection. When making non-through cuts with a dado blade, do not attempt to cut the full depth in one pass. Instead, take multiple light passes to reduce the load on the blade. A dado blade smaller than 10" will require removal of the riving knife, because the riving knife will be higher than the blade.

Through Cuts

A through cut is a sawing operation in which the workpiece is completely sawn through, as shown in the **Figure** below. Examples of through cuts are rip cuts, cross cuts, miter cuts, and beveled cuts. The blade guard assembly **MUST** be used when performing through cuts.

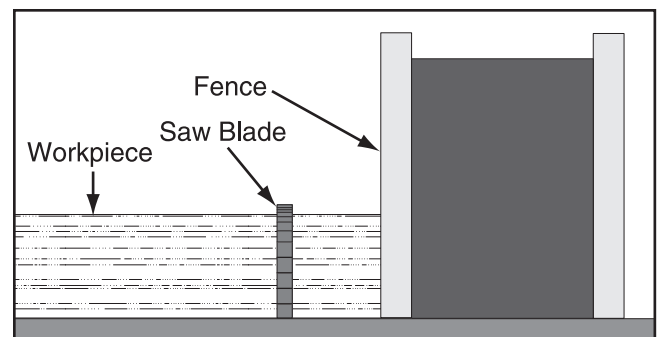

Figure 42. Example of a through cut (blade guard not shown for illustrative clarity).



Workpiece Inspection

Some workpieces are not safe to cut on this machine or may need to be modified before they can be safely cut. **Before cutting, inspect all workpieces for the following:**

- **Material Type:** This machine is intended for cutting natural and man-made wood products, laminate covered wood products, and some plastics. Cutting drywall or cementitious backer board creates extremely fine dust and may reduce the life of the motor bearings. This machine is NOT designed to cut metal, glass, stone, tile, etc.; cutting these materials with a table saw greatly increases the risk of injury and damage to the saw or blade.
- **Foreign Objects:** Nails, staples, dirt, rocks and other foreign objects are often embedded in wood. While cutting, these objects can become dislodged and hit the operator, cause kickback, or break the blade, which might then fly apart. Always visually inspect your workpiece for these items. If they can't be removed, DO NOT cut the workpiece.
- **Large/Loose Knots:** Loose knots can become dislodged during the cutting operation. Large knots can cause kickback and machine damage. Choose workpieces that do not have large/loose knots or plan ahead to avoid cutting through them.
- **Wet or "Green" Stock:** Cutting wood with a moisture content over 20% causes unnecessary wear on the blades, increases the risk of kickback, and yields poor results.
- **Excessive Warping:** Workpieces with excessive cupping, bowing, or twisting are dangerous to cut because they are unstable and may move unpredictably when being cut.
- **Minor Warping:** Slightly cupped workpieces can be safely supported with cupped side facing the table or fence; however, workpieces supported on the bowed side will rock during the cut, which could cause kickback.

Blade Requirements

The riving knife included with this machine is 0.1" (2.5mm) thick and is only designed for 10" diameter blades.

When choosing a main blade, make sure the blade size meets the requirements listed below. The thickness of the blade body and teeth can be measured with calipers or any precision measuring device.

Blade Size Requirements:

- Body Thickness: 0.071"-0.094" (1.8-2.4mm)
- Kerf (Tooth) Thickness: 0.102"-0.126" (2.6-3.2mm)

Blade Selection

This section on blade selection is by no means comprehensive. Always follow the saw blade manufacturer's recommendations to ensure safe and efficient operation of your table saw.

Ripping Blade Features:

- Best for cutting with the grain
- 20-40 teeth
- Flat-top ground tooth profile
- Large gullets for large chip removal

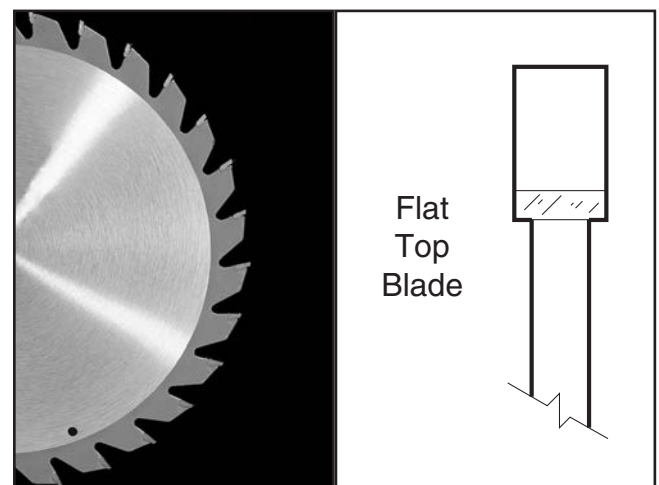

Figure 43. Ripping blade.



Crosscut blade features:

- Best for cutting across the grain
- 60-80 teeth
- Alternate top bevel tooth profile
- Small hook angle and a shallow gullet

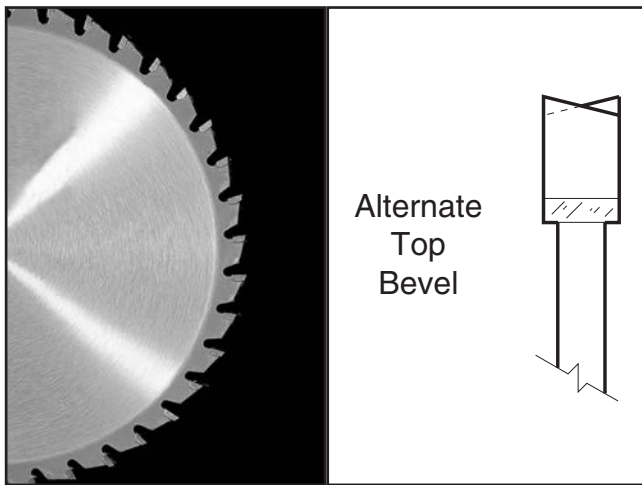

Figure 44. Crosscutting blade.

Laminate blade features:

- Best for cutting plywood or veneer
- 40-80 teeth
- Triple chip tooth profile
- Very shallow gullet

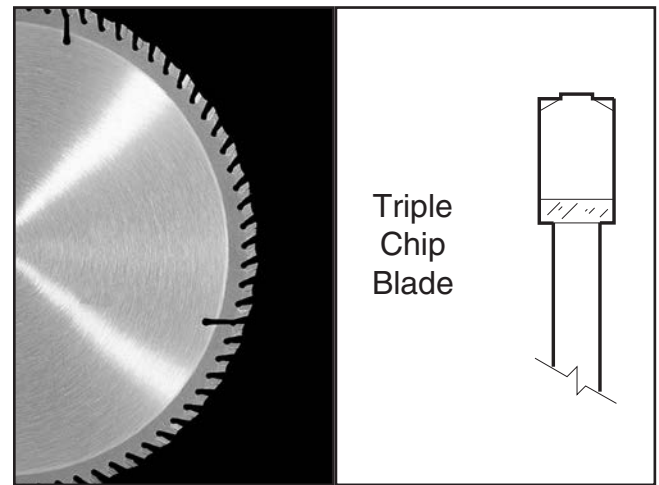

Figure 46. Laminate blade.

Combination blade features:

- Designed to cut both with and across grain
- 40-50 teeth
- Alternate top bevel and flat, or alternate top bevel and raker tooth profile
- Teeth are arranged in groups
- Gullets are small and shallow (similar to a cross-cut blade), then large and deep (similar to a ripping blade)

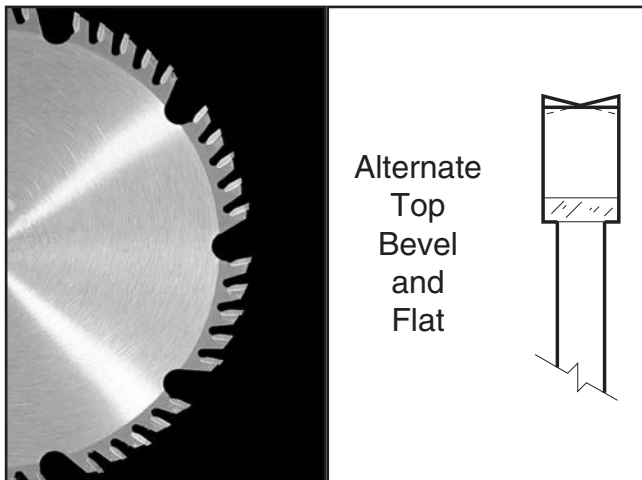

Figure 45. Combination blade.

Thin Kerf Blade: A blade with thinner kerf than a standard blade. Since the spreader/riving knife included with this table saw is sized for standard blades, thin kerf blades cannot be used on this saw unless they meet the **Blade Requirements** specified in this manual; otherwise, they will increase the risk of kickback.

Dado Blades

Stacked Dado Blade (see below): Multiple blades are stacked together to control the cutting width. Stacked dado blades are more expensive than wobble blades, but typically produce higher quality results.

Wobble Dado Blade: A single blade mounted at a slight angle on an arbor hub. The blade angle is adjustable on the hub, and the width of the dado cut is controlled by the angle setting of the blade.

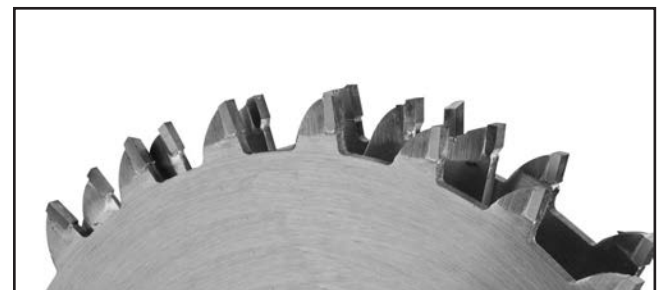

Figure 47. Stacked dado blade.



Blade Installation

CAUTION

The saw blade is sharp. Use extra care or wear gloves when handling the blade or working near it.

Review this section, even if your saw blade came pre-installed.

To install the blade:

1. DISCONNECT THE SAW FROM POWER!
2. Put on heavy leather gloves and raise the arbor all the way up.
3. Remove the table insert and blade guard/riving knife, depending on what is installed.
4. Use the arbor wrenches to loosen and remove the arbor nut, flange, and blade.

Note: *The arbor nut has right hand threads; turn it counterclockwise to loosen.*

5. Slide the blade over the arbor with the teeth facing the front of the saw, as shown in **Figure 48**.

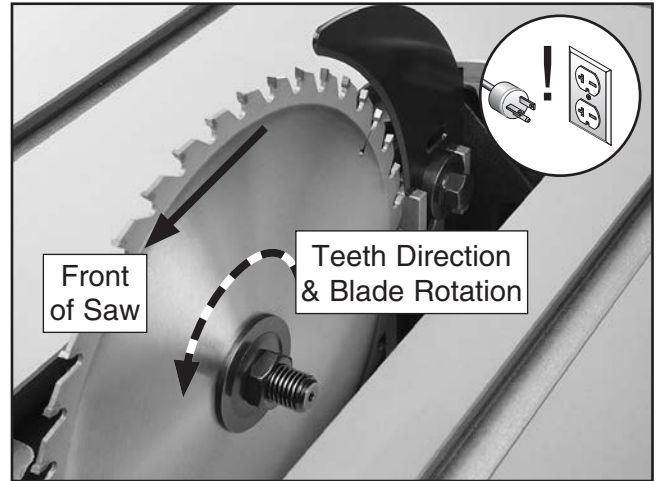

Figure 48. Example of correct blade direction.

6. Re-install the arbor flange and the arbor nut, and tighten them against the blade with the wrenches included with the saw. DO NOT overtighten.



Blade Guard Assembly

The term "blade guard" refers to the assembly that consists of the guard, spreader, and anti-kickback pawls (see **Figure** below). Each of these components have important safety functions.

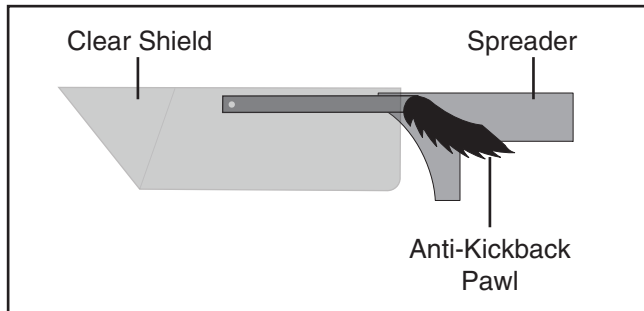

Figure 49. Blade guard assembly components.

Blade Guard

The guard encloses the top of the blade to reduce the risk of accidental blade contact and contain flying chips or dust.

The guard is designed to lift as the workpiece is pushed into the blade, remain in contact with the workpiece during the cut, then return to a resting position against the table when the cut is complete. When installed and properly maintained, the guard is an excellent tool for reducing the risk of injury when operating the table saw.

To ensure that the guard does its job effectively, it **MUST** be installed and adjusted so that it moves up and down properly to accommodate workpieces and maintain coverage over the blade.

Spreader

The spreader is a metal plate that prevents the freshly cut pieces of the workpiece from pinching the backside of the blade and causing a kickback. It also acts as a barrier behind the blade to shield hands from being pulled into the blade if a kickback occurs.

!WARNING

In order to work properly, the spreader cannot be bent or misaligned with the blade. If the spreader gets accidentally bent, take the time to straighten it or just replace it. Using a bent or misaligned spreader will increase the risk of kickback! Refer to Page 68 to check or adjust alignment if necessary.

Anti-Kickback Pawls

The anti-kickback pawls allow the workpiece to travel in only one direction. If the workpiece moves backwards, such as during a kickback, the pawls will dig into the workpiece to slow or stop it.

To work properly, the pawls must return to their bottom-most position after pivoting, as shown in **Figure 50**, and they must not be engaged in the arresting hooks.

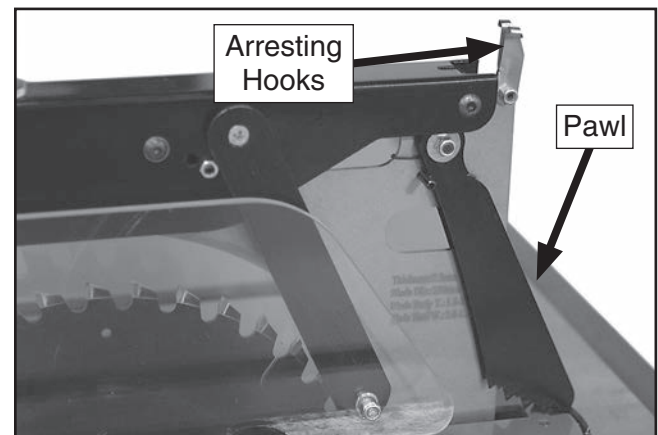

Figure 50. Pawls in return position.



If the pawls fail to return to the bottom position, the pivot spring may have been dislodged or broken and will need to be fixed/replaced.

The anti-kickback pawls and arresting hooks are constructed to comply with the *UL Standard for Safety for Stationary and Fixed Electric Tools, UL 987* (Seventh Edition).

Disabling Pawls

To disable the pawls, rotate the arresting hooks downward, then place the pawls on each of the hooks, as shown in **Figure 51**.

Use your best judgment before retracting the pawls, as they are provided for your safety. Certain situations could warrant retracting the pawls. For example, you might retract the pawls if you are concerned about them scratching a delicate workpiece, or if you believe that they will obstruct a narrow workpiece and cause feeding difficulty or loss of control.

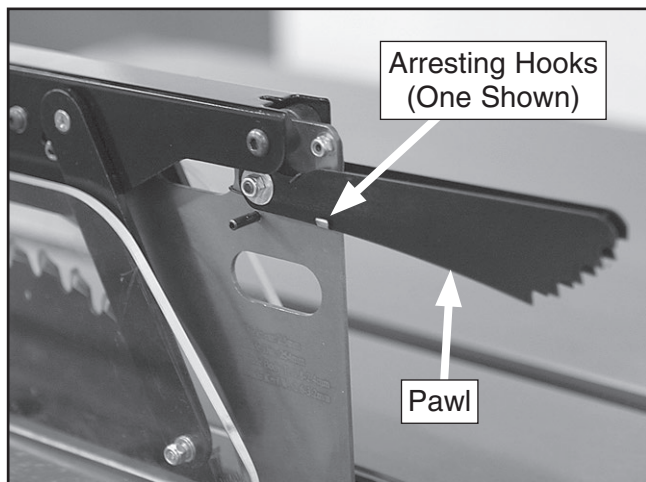

Figure 51. Pawl disabled.

!WARNING

We do not recommend disabling the pawls during normal operations unless absolutely necessary. In most situations, disabling the pawls will increase your risk of serious personal injury in the event of a kickback.

Enabling Pawls

To enable the pawls, lift up on each pawl and move them outward and down until they both touch the table surface, as shown in **Figure 50** on **Page 37**.

When to Use the Blade Guard

The blade guard assembly **MUST** always be installed on the saw for all normal through cuts (those where the blade cuts all the way through the thickness of the workpiece).

When Not to Use the Blade Guard

The blade guard cannot be used on any non-through cuts (those in which the blade does not cut all the way through the thickness of the workpiece).

Sometimes the blade guard or its components can get in the way when cutting very narrow workpieces or other specialized cuts. Because the blade guard is provided to decrease your risk of injury, it should not be used if it gets in the way of making a safe cut. Use good judgment!

IMPORTANT: Whenever the blade guard cannot be used, the riving knife must be installed.



Riving Knife

The riving knife works the same way as the spreader on the blade guard assembly. It is a metal plate that prevents the newly cut workpiece from pinching the backside of the blade and causing kickback.

The key difference between the spreader and the riving knife is that the riving knife mounts below the blade's highest point of rotation, as shown in **Figure 52**.

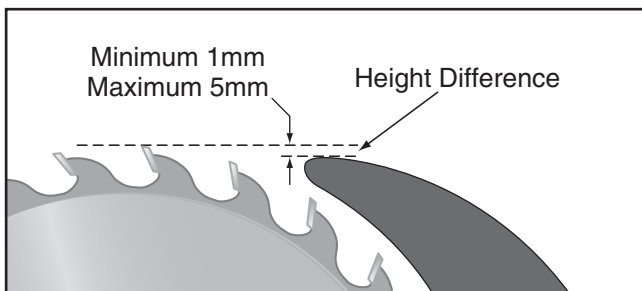

Figure 52. Height difference between riving knife and blade.

The height difference between the riving knife and the blade allows the workpiece to pass over the blade during non-through cuts (those in which the blade does not cut all the way through the thickness of the workpiece).

The riving knife acts as a barrier behind the blade to reduce the risk of hands being pulled into the blade if a kickback occurs.

The riving knife must be kept within the range shown in **Figure 53**. For that reason, we only recommend using a 10" blade for operations that require use of the riving knife.

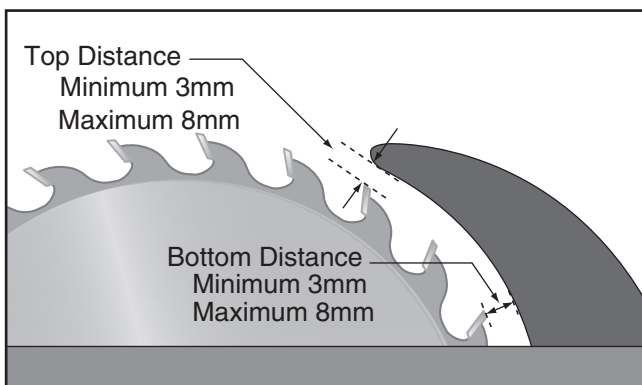

Figure 53. Allowable top and bottom distances between riving knife and blade.

! WARNING

To ensure that the riving knife works safely, it **MUST** be aligned with and correctly adjusted to the blade. Refer to Page 68 to check or adjust the riving knife alignment.

How to Install the Riving Knife

The riving knife is installed in a similar manner to the blade guard and spreader. Refer to **Blade Guard** on **Page 37** for installation instructions.

When to Use the Riving Knife

Use the riving knife for all non-through cuts made with a standard table saw blade (i.e., dados or rabbet cuts in which a dado blade is NOT used, and when using a tenoning jig).

Also, use the riving knife for those special operations where the blade guard or its components get in the way of safe operation, such as with very narrow cuts.

When Not to Use the Riving Knife

The riving knife **CANNOT** be used with a dado blade. Otherwise, the riving knife height will exceed the blade height and the workpiece will hit the riving knife during the cut, forcing the operator into a dangerous situation of trying to turn the saw off with the workpiece stuck halfway through the cut.

In addition, although it is possible to use the riving knife for through cutting operations, the blade guard assembly offers far more injury protection and risk reduction than the riving knife. Therefore, **we strongly recommend** that you use the blade guard assembly instead of the riving knife for through cuts.



Ripping

"Ripping" means cutting with the grain of a natural wood workpiece. In other man-made materials such as MDF or plywood, ripping simply means cutting lengthwise.

!WARNING

Serious injury can be caused by kickback. Kickback is a high-speed expulsion of stock from the table saw toward an operator. The operator or bystanders may be struck by flying stock, or the operator's hands can be pulled into the blade during kickback.

To make a rip cut:

1. Review **Preventing Kickback** on **Page 13** and take the necessary precautions to prevent kickback.
2. If using natural wood, joint one long edge of the workpiece on a jointer.
3. **DISCONNECT THE SAW FROM POWER!**
4. Ensure that the blade guard/spreader is installed.
5. Set the fence to the desired width of cut on the scale.
6. Adjust the blade height so the highest saw tooth protrudes approximately $\frac{1}{4}$ " above the workpiece.
7. Set up safety devices such as featherboards or other anti-kickback devices.
8. Rotate the blade to make sure it does not come into contact with any of the safety devices.
9. Plug the saw into the power source, turn it **ON**, and allow it to reach full speed.

Note: *The jointed edge of the workpiece must slide against the fence during the cutting operation.*

10. Use a push stick to feed the workpiece through the saw blade, as shown in **Figure 54**, until the workpiece is completely past the saw blade.

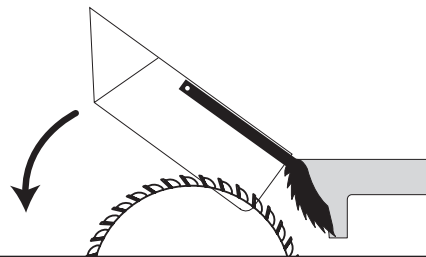

Figure 54. Typical ripping operation.

!WARNING

Turn OFF the saw and allow the blade to come to a complete stop before removing the cut-off piece. Failure to follow this warning could result in serious personal injury.

!WARNING



Keep the blade guard installed and in the down position. Failure to do this could result in serious personal injury or death.



Crosscutting

"Crosscutting" means cutting across the grain of a natural wood workpiece. In other man-made materials, such as MDF or plywood, crosscutting means cutting across the width of the workpiece.

To make a crosscut using the miter gauge:

1. DISCONNECT THE SAW FROM POWER!
2. Ensure that the blade guard/spreader is installed.
3. Move the rip fence aside and position the miter gauge, adjusted to 90°, in a miter slot.
4. Adjust the blade height so the teeth protrude approximately 1/4" above the workpiece.
5. Slide the miter gauge near the blade and adjust the workpiece so the blade will cut on the waste side of the line.
6. Plug in the table saw, turn it **ON**, and allow it to reach full speed.
7. Hold the workpiece firmly against the face of the miter gauge (**Figure 55**), and ease it through the blade until the workpiece is completely past the saw blade.

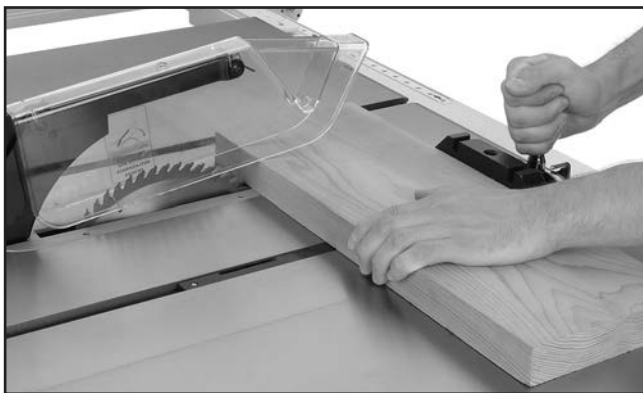

Figure 55. Typical crosscutting operation.

⚠️ WARNING

Turn **OFF** the saw and allow the blade to come to a complete stop before removing the cut-off piece. Failure to follow this warning could result in serious personal injury

Miter Cuts

A miter is an angled crosscut. Miters are usually cut in the same manner as crosscuts, using the miter gauge and a predetermined mark on the workpiece.

To perform a miter cut:

1. DISCONNECT THE SAW FROM POWER!
2. Ensure that the blade guard/spreader is installed.
3. Determine the angle of your cut. If the angle needs to be very precise, use a protractor to set the miter gauge to the blade.
4. Place the face of the miter gauge against the edge of the workpiece and place the bar across the face of the workpiece. Use the bar as a guide to mark your cut, as shown in **Figure 56**.



Figure 56. Example of marking miter line.

5. Place the miter gauge back into the slot and hold the workpiece firmly against the miter gauge body. Slide the miter gauge near the blade and adjust the workpiece so the blade will cut on the waste side of the line.
6. Proceed to make the cut in the same manner as described in the **Crosscutting** instructions.



Blade Tilt/Bevel Cuts

When the blade tilt stop bolts are properly adjusted (**Page 65**), the blade tilt handwheel allows the operator to tilt the blade to the left, anywhere between 0° and 45°. This is used most often when cutting bevels, compound miters or chamfers. **Figure 57** shows an example of the blade when tilted to 45°.



Figure 57. Blade tilted to 45° for bevel cutting on a typical table saw.

Dado Cutting

Commonly used in furniture joinery, a dado is a straight channel cut in the face of the workpiece. Dadoes can be cut using either a dedicated dado blade or a standard saw blade. **Figure 58** shows a cutaway view of a dado cut being made with a dado blade.

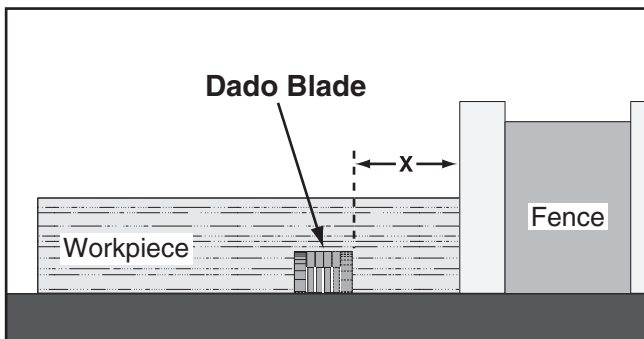

Figure 58. Example of a dado cut with a dado blade.

!WARNING

DO NOT make through cuts with a dado blade. Dado blades are only intended for non-through cuts. Failure to heed this warning could result in serious injury.

Installing a Dado Blade

1. DISCONNECT THE SAW FROM POWER!
2. Remove the table insert, the blade guard assembly or riving knife, and the saw blade.
3. Attach and adjust the dado blade system according to the dado blade manufacturer's instructions
4. Install the dado table insert.

!WARNING

Dado blades have a higher risk of kickback than normal blades because their larger size applies stronger forces to the workpiece. This risk increases relative to the depth and width of the cut. To minimize your risk of serious personal injury, ensure that stock is flat and straight, and make multiple light cuts (rather than one deep cut) to achieve the desired cutting depth.

!WARNING

DO NOT make through cuts with a dado blade. Dado blades are only intended for non-through cuts. Failure to heed this warning could result in serious injury.

!WARNING

Never try to dado a warped board by holding it down against the table. If kickback occurs, your hand will likely be pulled into the blade, resulting in serious personal injury.



Cutting Dados with a Dado Blade

The **Figure** below demonstrates the sequential process of making multiple, light cuts that get progressively deeper. The actual number of cuts used should be determined by workpiece hardness, total dado depth, and feed rate. In general, if you hear the motor slow down during the cut, you are cutting too deep or feeding too fast.

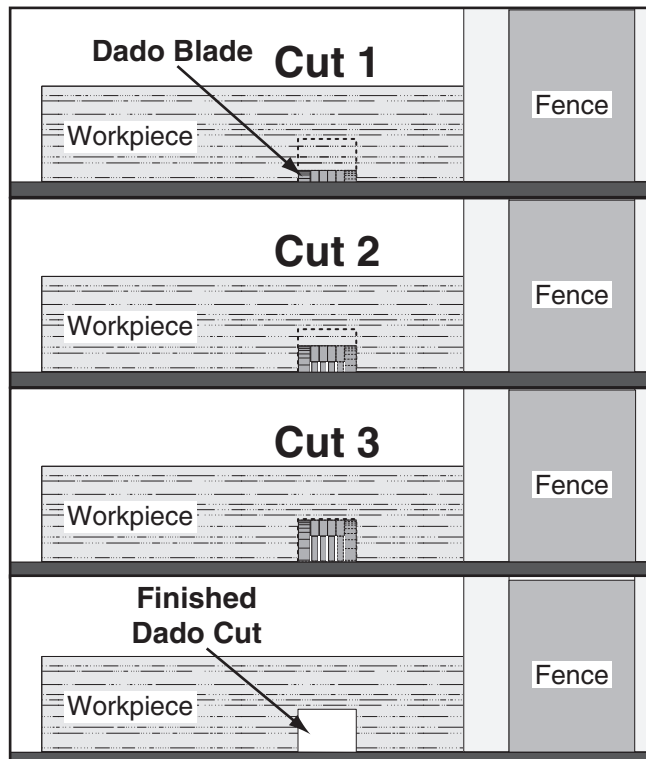

Figure 59. Example of dado being cut with multiple light cuts, instead of one deep cut.

⚠ WARNING

Always use push sticks, featherboards, push paddles and other safety accessories whenever possible to increase safety and control during operations that require the blade guard and spreader to be removed from the saw. **ALWAYS** replace the blade guard after dadoing is complete.

To cut a dado with a dado blade:

1. Adjust the dado blade to the desired depth of cut.
2. Adjust the distance between the fence and the inside edge of the blade, as shown in **Figure 58**, to dado the length of a workpiece.
 - If dadoing across the workpiece, use the miter gauge and carefully line up the desired cut with the dado blade. **DO NOT** use the fence in combination with the miter gauge.
3. Reconnect the saw to the power source.
4. Turn the saw **ON**. The blade should run smooth, with no vibrations.
5. When the blade has reached full speed, perform a test cut with a scrap piece of wood.
6. If the cut is satisfactory, repeat the cut with the actual workpiece.



Cutting Dados with a Standard Blade

A ripping blade (described on **Page 34**) is typically the best blade to use for cutting dados when using a standard blade, because it removes sawdust very efficiently.

To use a standard saw blade to cut dados:

1. DISCONNECT SAW FROM POWER!
2. Mark the width of the dado cut on the workpiece. Include marks on the edge of the workpiece so the cut path can be aligned when the workpiece is lying on the table.
3. Raise the blade up to the desired depth of cut (depth of dado channel desired).
4. Set the saw up for the type of cut you need to make, depending on if it is a rip cut (**Page 40**) or crosscut (**Page 41**).
5. Align the blade to cut one of the dado sides, as shown in **Figure 60**.

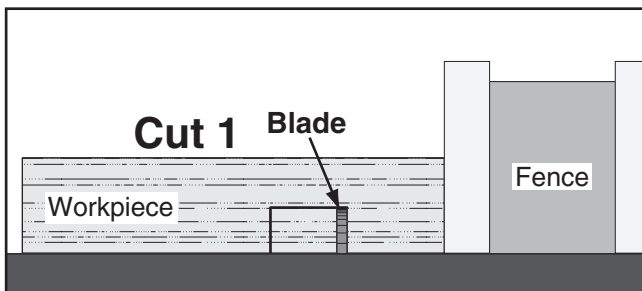

Figure 60. First cut for a single-blade dado.

6. Reconnect the saw to the power source and turn the saw **ON**. Allow the blade to reach full speed, then perform the cutting operation.
7. Repeat the cutting operation on the other side of the dado channel, as shown in **Figure 61**.

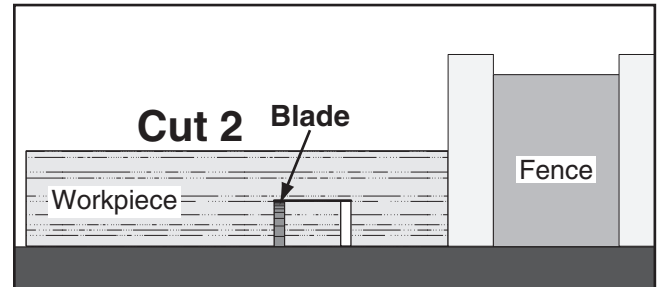

Figure 61. Second cut for a single blade dado.

8. Make additional cuts (see **Figure 62**) in the center of the dado to clear out the necessary material. The dado is complete when the channel is completely cleared out.



Figure 62. Additional single blade dado cuts.



Rabbet Cutting

Commonly used in furniture joinery, a rabbet is an L-shaped groove cut in the edge of the workpiece. Rabbets can be cut with either a dado blade or a standard saw blade.

Rabbet cutting on the edge of the workpiece with a dado blade requires a sacrificial fence (**Figure 63**). Make the sacrificial fence the same length as the fence and $\frac{3}{4}$ " thick. Attach it to the fence with screws or clamps, making sure they are all secure and tight. Raise the blade into the sacrificial fence to the height needed.

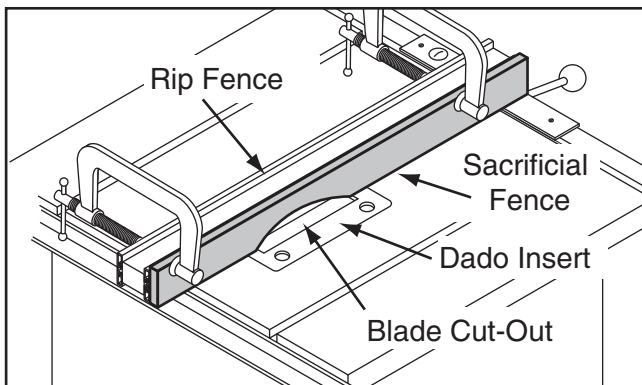

Figure 63. Sacrificial fence.

!WARNING

Dado blades have a higher risk of kickback than normal blades because their larger size applies stronger forces to the workpiece. This risk increases relative to the depth and width of the cut. To minimize your risk of serious personal injury, ensure that stock is flat and straight, and make multiple light cuts (rather than one deep cut) to achieve the desired cutting depth.

!CAUTION

Always use push sticks, featherboards, push paddles and other safety accessories whenever possible to increase safety and control during operations which require that the blade guard be removed from the saw. **ALWAYS** replace the blade guard after dadoing is complete.

Cutting Rabbets with a Dado Blade

1. DISCONNECT SAW FROM POWER!
2. Adjust the dado blade to the height needed for the rabbeting operation. When cutting deep rabbets, take more than one pass to reduce the risk of kickback.
3. Adjust the fence and align the workpiece to perform the cutting operation, as shown in **Figure 64**.

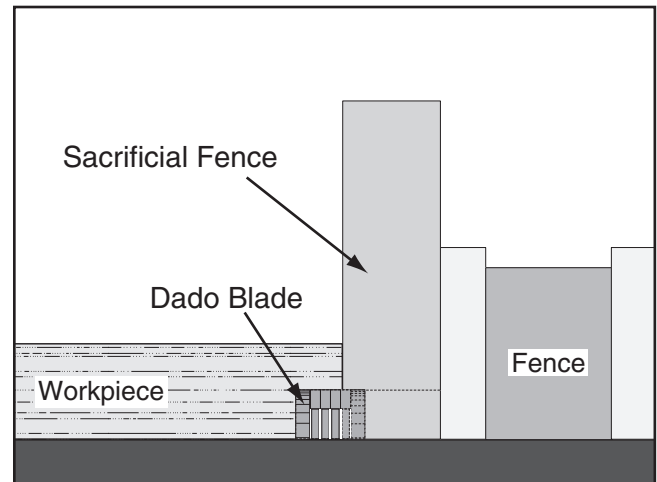

Figure 64. Rabbet cutting.

4. Reconnect the saw to the power source and turn the saw **ON**. When the blade has reached full speed, perform a test cut with a scrap piece of wood.
—If the cut is satisfactory, repeat the cut with the final workpiece.



Cutting Rabbets with a Standard Blade

A ripping blade is typically the best blade to use for cutting rabbets when using a standard blade because it removes sawdust very efficiently. (See **Page 34** for blade details.) Also, a sacrificial fence is not required when cutting rabbets with a standard blade.

To cut rabbets with the standard blade:

1. DISCONNECT SAW FROM POWER!
2. Ensure that the riving knife and standard table insert are installed.
3. Mark the width of the rabbet cut on the edge of the workpiece, so you can clearly identify the intended cut while it is laying flat on the saw table.
4. Raise the blade up to the desired depth of cut (depth of rabbet channel desired).
5. Stand the workpiece on edge, as shown in **Figure 65**, then adjust the fence so the blade is aligned with the inside of your rabbet channel.

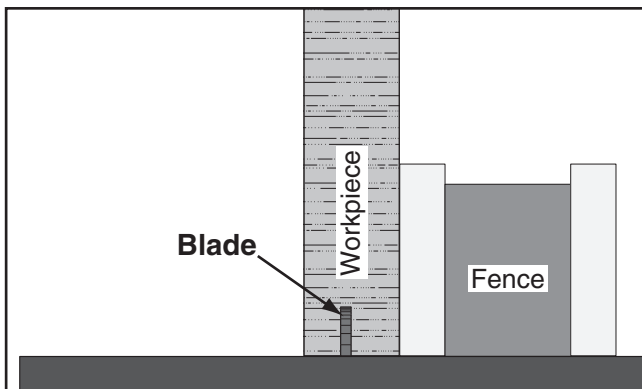
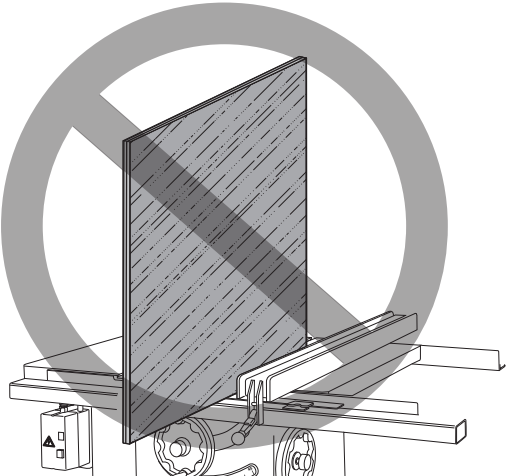

Figure 65. Rabbet cutting with a standard blade.

—If the workpiece is very tall, or is unstable when placed against the fence, lay it flat on the table and use a dado blade to perform the rabbet cut.

! WARNING



DO NOT place a tall board on edge to perform a rabbet cut with a standard blade. Workpieces that are too tall to properly support with the fence can easily shift during operation and cause kickback. Instead, place the stock flat on the saw and perform the rabbet cut with a dado blade, as instructed on **Page 45**.

6. Reconnect the saw to the power source, then perform the cut.
7. Lay the workpiece flat on the table, as shown in **Figure 66**, adjust the saw blade height to intersect with the first cut, then perform the second cut to complete the rabbet.

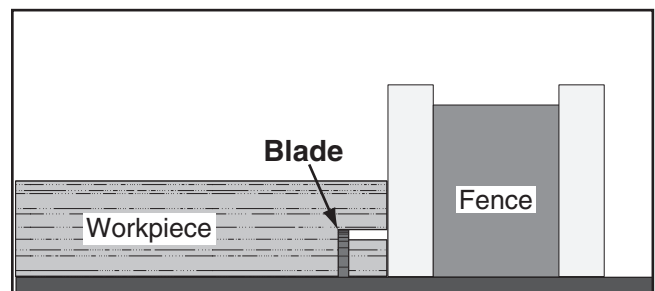

Figure 66. Second cut to create a rabbet.



Resawing

!WARNING

Resawing operations require proper procedures to avoid serious injury. Extra care must be taken to prevent kickback when resawing. Any tilting or movement of the workpiece away from the fence will cause kickback. Be certain that stock is flat and straight. Failure to follow these warnings could result in serious personal injury.

Resawing is the process of cutting a thick piece of stock into one or more thinner pieces. Although resawing can be done with a table saw, we strongly recommend that you use a bandsaw instead.

A bandsaw is the ideal machine for resawing, and resawing with one is fairly easy and safe. A table saw is not intended for resawing, and resawing with one is difficult and dangerous due to the increased risk of kickback from binding and deep cuts, and the increased risk of injury from having to remove the guard.

If you insist on resawing with a table saw, DO NOT do so without using a resaw barrier and wearing a full face shield. The following instructions describe how to build a resaw barrier and add an auxiliary fence to your standard fence, to reduce the risk injury from resawing on a table saw.

Note: To determine the maximum resawing height for this table saw, find the maximum blade height, then double it and subtract $\frac{1}{8}$ ".

Making Resaw Barrier

The resaw barrier acts in tandem with the rip fence when resawing to provide tall support for the workpiece to minimize the probability of it binding against the blade and causing kickback.

Tools Needed:

	Qty
Table Saw	1
Jointer and Planer	Recommended
Clamps	2 Minimum
Drill and Drill Bits	1

Components Needed for Resaw Barrier:

Wood* $\frac{3}{4}$ " x $5\frac{1}{2}$ " x Length of Fence	1
Wood* $\frac{3}{4}$ " x 3" x Length of Fence	1
Wood Screws #8 x 2"	4
Wood Glue	As Needed

*Only use furniture-grade plywood, kiln dried hardwood, or HDPE plastic to prevent warping.

To build the resaw barrier:

1. Cut your wood pieces to the size specified above. If you are using hardwood, cut the pieces oversize, then joint and plane them to the correct size to make sure they are square and flat.
2. Pre-drill and countersink four holes approximately $\frac{3}{8}$ " from the bottom of the $5\frac{1}{2}$ " tall wood piece.
3. Glue the end of the 3" board, then clamp the boards at a 90° angle with the larger board in the vertical position, as shown in **Figure 67**, fasten together with the wood screws.

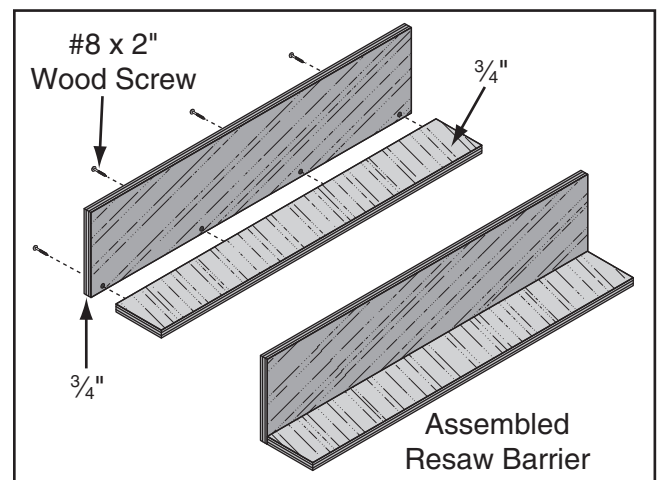

Figure 67. Resaw barrier.



Auxiliary Fence

The auxiliary fence is necessary if you are resawing a workpiece that is taller than it is wide. It should be no less than 1/2" shorter than the board to be resawn.

Components Needed for the Auxiliary Fence:

Wood* 3/4" x (Height) x Length of Fence 1

* Only use furniture-grade plywood, kiln dried hardwood, or HDPE plastic to prevent warping.

Tools Needed for the Auxiliary Fence:

Table Saw 1

Jointer and Planer Recommended

Clamps 2 Minimum

To build the auxiliary fence:

1. Cut the auxiliary fence board to size. If you are using hardwood, cut the board oversize, then joint and plane the board to the correct size to make sure the board is square and flat.
2. Unthread the fence face mounting hardware and remove the fence face from the fence assembly.
3. Place the auxiliary fence next to the fence face you removed in **Step 1**, mark the location of the nine mounting holes on the auxiliary fence, then drill the holes.
4. Use the mounting hardware that had previously attached the fence face to attach the auxiliary fence. The end result should be similar to **Figure 68**.

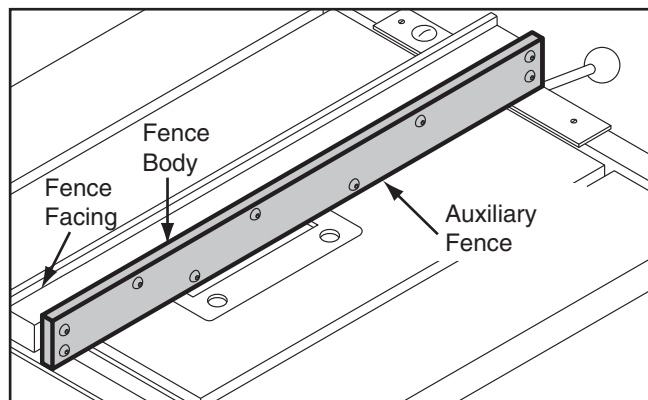

Figure 68. Auxiliary fence.

Resawing Operations

The table saw motor is pushed to its limits when resawing. If the motor starts to bog down, slow down your feed rate. Motor overloading and blade wear can be reduced by using a ripping blade. Ripping blades are designed to clear the sawdust quickly.

Components Needed for Resawing:

Zero-clearance Insert 1

Ripping Blade 10" 1

Clamps 2

Shop Made Auxiliary Fence 1

Shop Made Resaw Barrier 1

WARNING

You may experience kickback during this procedure. Stand to the side of the blade and wear a full face shield to prevent injury when resawing.

To perform resawing operations:

1. DISCONNECT SAW FROM POWER!
2. Remove the standard table insert and the blade guard assembly.
3. Install a ripping blade, install the riving knife, lower the blade below the table, then install the optional Model T20916 zero clearance table insert.
4. Attach the auxiliary fence and set it to the desired width.

Note: When figuring out the correct width, don't forget to account for blade kerf and the inaccuracy of the fence scale while the auxiliary fence is installed.

5. Place the workpiece against the auxiliary fence and slide the resaw barrier against the workpiece, as shown in **Figure 69**. Now clamp the resaw barrier to the top of the table saw at both ends.



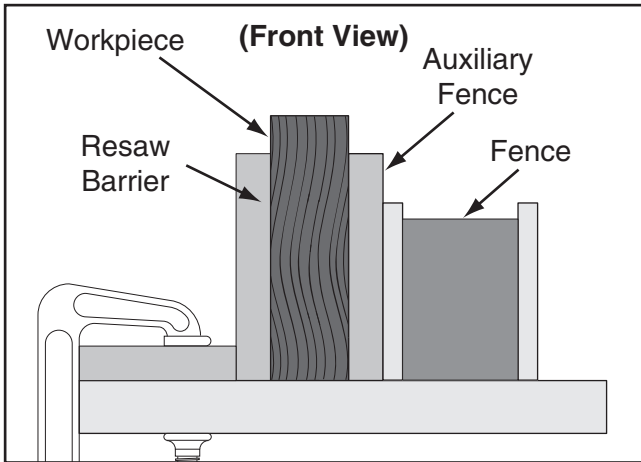

Figure 69. Ideal resaw workpiece setup.

6. Lower the blade completely below the table, and slide the workpiece over the blade to make sure it moves smoothly and fits between the resaw barrier and fence.
7. Raise the blade approximately an inch, or close to half the height of the workpiece (**Figure 70**), whichever is less.

! WARNING

The danger of kickback increases relative to the depth of a cut. Reduce the risk of kickback by making multiple passes to achieve the desired depth of cut. Failure to follow these warnings could result in serious personal injury.

! CAUTION

Always use push sticks or push paddles to increase safety and control during operations which require that the blade guard and spreader must be removed from the saw. **ALWAYS** replace the blade guard after resawing is complete.

8. Plug in the table saw, turn it **ON**, and use a push stick or push block to feed the workpiece through the blade, using a slow and steady feed rate.
9. Flip the workpiece end for end, keeping the same side against the fence, and run the workpiece through the blade.

10. Repeat **Steps 7–9** until the blade is close to half of the height of the board to be resawn. The ideal completed resaw cut will leave an $\frac{1}{8}$ " connection when the resawing is complete as shown in **Figure 70**. Leaving an $\frac{1}{8}$ " connection will reduce the risk of kickback.

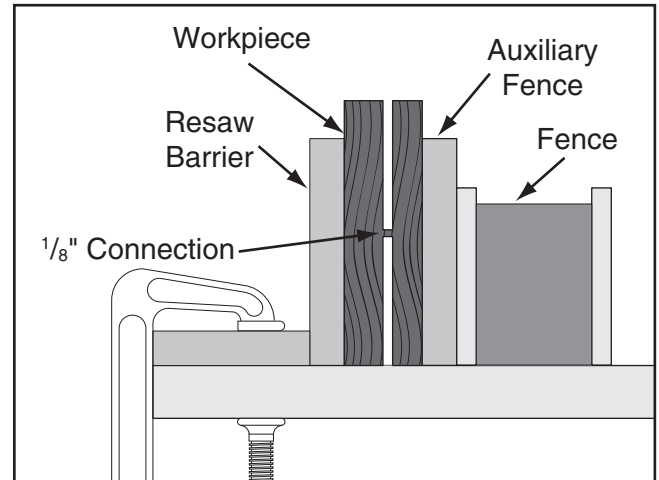

Figure 70. Ideal completed resaw cut.

11. Turn **OFF** the table saw, then separate the parts of the workpiece and hand plane the remaining ridge to remove it.
12. When finished resawing, remove the resaw barrier and auxiliary fence, then re-install the blade guard/spreader or riving knife and standard table insert.



SECTION 5: SHOP MADE SAFETY ACCESSORIES

Featherboards

Easily made from scrap stock, featherboards provide an added degree of protection against kickback, especially when used together with push sticks. They also maintain pressure on the workpiece to keep it against the fence or table while cutting, which makes the operation easier and safer because the cut can be completed without the operator's hands getting near the blade. The angled ends and flexibility of the fingers allow the workpiece to move in only one direction.

Making a Featherboard

This sub-section covers the two basic types of featherboards: 1) Those secured by clamps, or 2) those secured with the miter slot.

Material Needed for Featherboard

- Hardwood $\frac{3}{4}$ " x 3" x 10" (Minimum)
- Hardwood $\frac{3}{4}$ " x 6" x 28" (Maximum) 1

Additional Material Needed for Mounting Featherboard in Miter Slot

- Hardwood $\frac{3}{8}$ " x (Miter Slot Width) x 5"L 1
- Wing Nut $\frac{1}{4}$ "-20..... 1
- Flat Head Screw $\frac{1}{4}$ "-20 x 2" 1
- Flat Washer $\frac{1}{4}$ "-20..... 1

To make a featherboard:

1. Cut a hardwood board approximately $\frac{3}{4}$ " thick to size. The length and width of the board can vary according to your design. Most featherboards are 10"–28" long and 3"–6" wide. Make sure the wood grain runs parallel with the length of the featherboard, so the fingers you will create in **Step 3** will bend without breaking.
2. Cut a 30° angle at one end of the board.

⚠ CAUTION

We recommend using a bandsaw for making fingers in the next step because it tends to be safer. A table saw can be used, but it will over-cut the underside of the ends, produce a thicker kerf, and require you to stop the blade half-way through the cut, which can be dangerous.

3. Make a series of end cuts with the grain $\frac{3}{8}$ "– $\frac{1}{4}$ " apart and 2"–3" long, as shown in **Figure 71 (A)**. Alternatively, start cuts at 2"–3" deep, then make them progressively deeper, as shown in **Figure 71 (B)**.

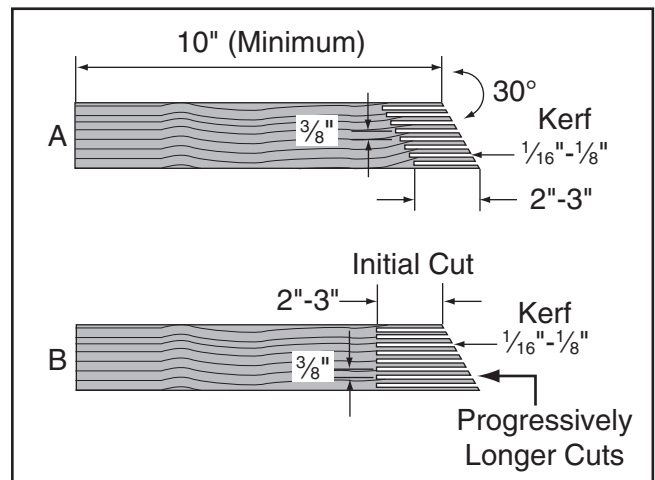

Figure 71. Patterns for featherboards (top view shown).

IMPORTANT: Cuts made across the grain result in weak fingers that easily break when flexed. When made correctly, the fingers should withstand flexing from moderate pressure. To test the finger flexibility, push firmly on the ends with your thumb. If the fingers do not flex, they are likely too thick (the cuts are too far apart).

NOTICE

Only Steps 1–3 are required to make a clamp-mounted featherboard. Refer to Page 52 for instructions on clamping.



- Rout a $\frac{1}{4}$ "- $\frac{3}{8}$ " wide slot 4"-5" long in the workpiece and 1"-2" from the short end of the featherboard (see **Figure 72**).

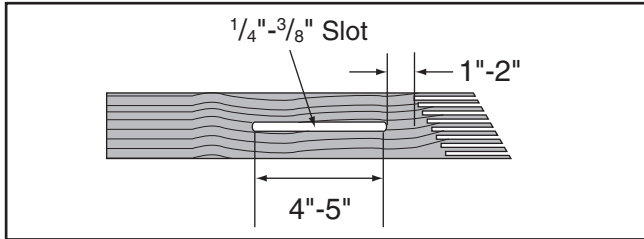

Figure 72. Slot routed in featherboard.

- Cut a miter bar that will fit in the table miter slot approximately 5" long, as shown in **Figure 73**.

Tip: Consider making the miter bar longer for larger featherboards—approximately half the length of the total featherboard—to support the force applied to the featherboard during use.

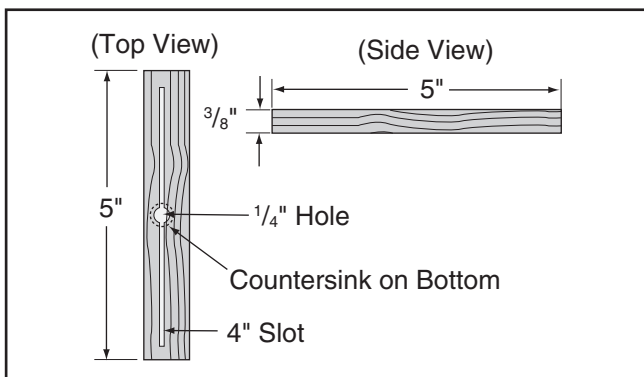

Figure 73. Miter bar pattern.

- Drill a $\frac{1}{4}$ " hole in the center of the bar, then countersink the bottom to fit a $\frac{1}{4}$ "-20 flat head screw.

- Mark a 4" line through the center of the countersunk hole in the center, then use a jig saw with a narrow blade to cut it out.
- Assemble the miter bar and featherboard with a $\frac{1}{4}$ "-20 x flat head screw, flat washer, and a wing nut or a star knob (see **Figure 74**). Congratulations! Your featherboard is complete.

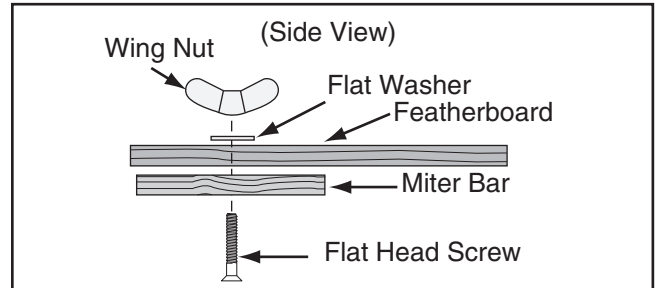

Figure 74. Assembling miter slot featherboard components.

Note: The routed slot, countersink hole, and the flat head screw are essential for the miter bar to clamp into the miter slot. When the wing nut is tightened, it will draw the flat head screw upward into the countersunk hole. This will spread the sides of the miter bar and force them into the walls of the miter slot, locking the featherboard in place.

Tip: The length of the flat head screw depends on the thickness of the featherboard—though $1\frac{1}{2}$ " to 2" lengths usually work.

Now, proceed to **Mounting Featherboard in Miter Slot** on **Page 52**.



Mounting Featherboards w/Clamps

1. Lower the saw blade, then adjust the fence to the desired width and secure it.
2. Place the workpiece against the fence, making sure it is 1" in front of the blade.
3. Place a featherboard on the table away from the blade so all fingers point forward and contact the workpiece (see **Figure 75**).

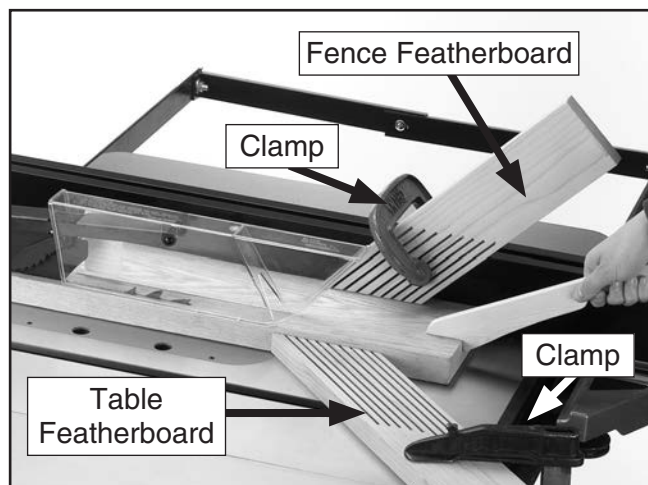

Figure 75. Example of featherboards secured with clamps.

4. Secure the featherboard to the table with a clamp.
5. Check the featherboard by pushing it with your thumb to ensure it is secure.
—If the featherboard moves, tighten the clamp more.
6. Mount a second featherboard to the fence with another clamp (see **Figure 75**), then repeat **Step 5** to ensure it is secure.

Mounting Featherboard in Miter Slot

1. Lower the saw blade, then adjust the fence to the desired width and secure it.
2. Place the workpiece evenly against the fence, making sure it is 1" in front of the blade.
3. Slide the featherboard miter bar into the miter slot, making sure the fingers slant toward the blade, as shown in **Figure 76**.

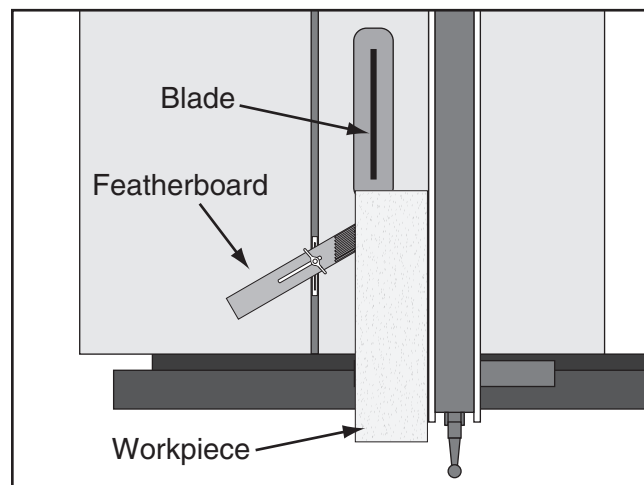

Figure 76. Featherboard installed in miter slot and supporting workpiece for ripping cut.

4. Position the fingered edge of the featherboard against the edge of the workpiece, so that all of the fingers contact the workpiece. Slide the featherboard toward the blade until the first finger is nearly even with the end of the workpiece, which should be 1" away from the blade.
5. Double check the workpiece and the featherboard to ensure they are properly positioned as described in **Step 4**. Then secure the featherboard to the table. Check the featherboard by hand to make sure it is tight.

Note: *The featherboard should be placed firmly enough against the workpiece to keep it against the fence but not so tight that it is difficult to feed the workpiece.*



Push Sticks

When used correctly, push sticks reduce the risk of injury by keeping hands away from the blade while cutting. In the event of an accident, a push stick can also absorb damage that would have otherwise happened to hands or fingers.

Using a Push Stick

Use push sticks whenever your hands will get within 12" of the blade. To maintain control when cutting large workpieces, start the cut by feeding with your hands then use push sticks to finish the cut, so your hands are not on the end of the workpiece as it passes through the blade.

Feeding: Place the notched end of the push stick against the end of the workpiece (see inset **Figure** below), and move the workpiece into the blade with steady downward and forward pressure.

Supporting: A second push stick can be used to keep the workpiece firmly against the fence while cutting. When using a push stick in this manner, only apply pressure before the blade; otherwise, pushing the workpiece against or behind the blade will increase the risk of kickback (see "Push Stick Prohibition Zone" in the **Figure** below).

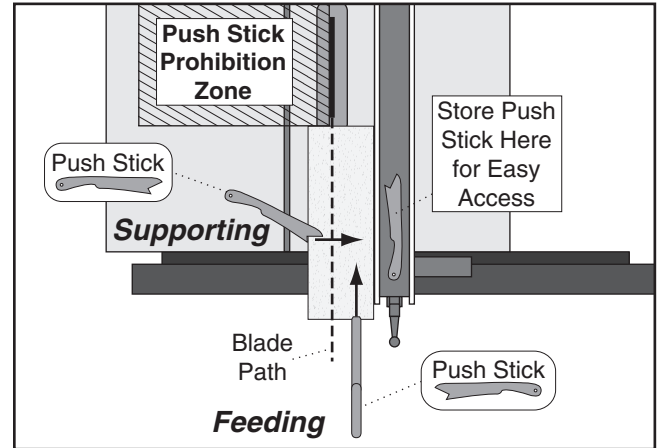

Figure 77. Using push sticks to rip narrow stock.

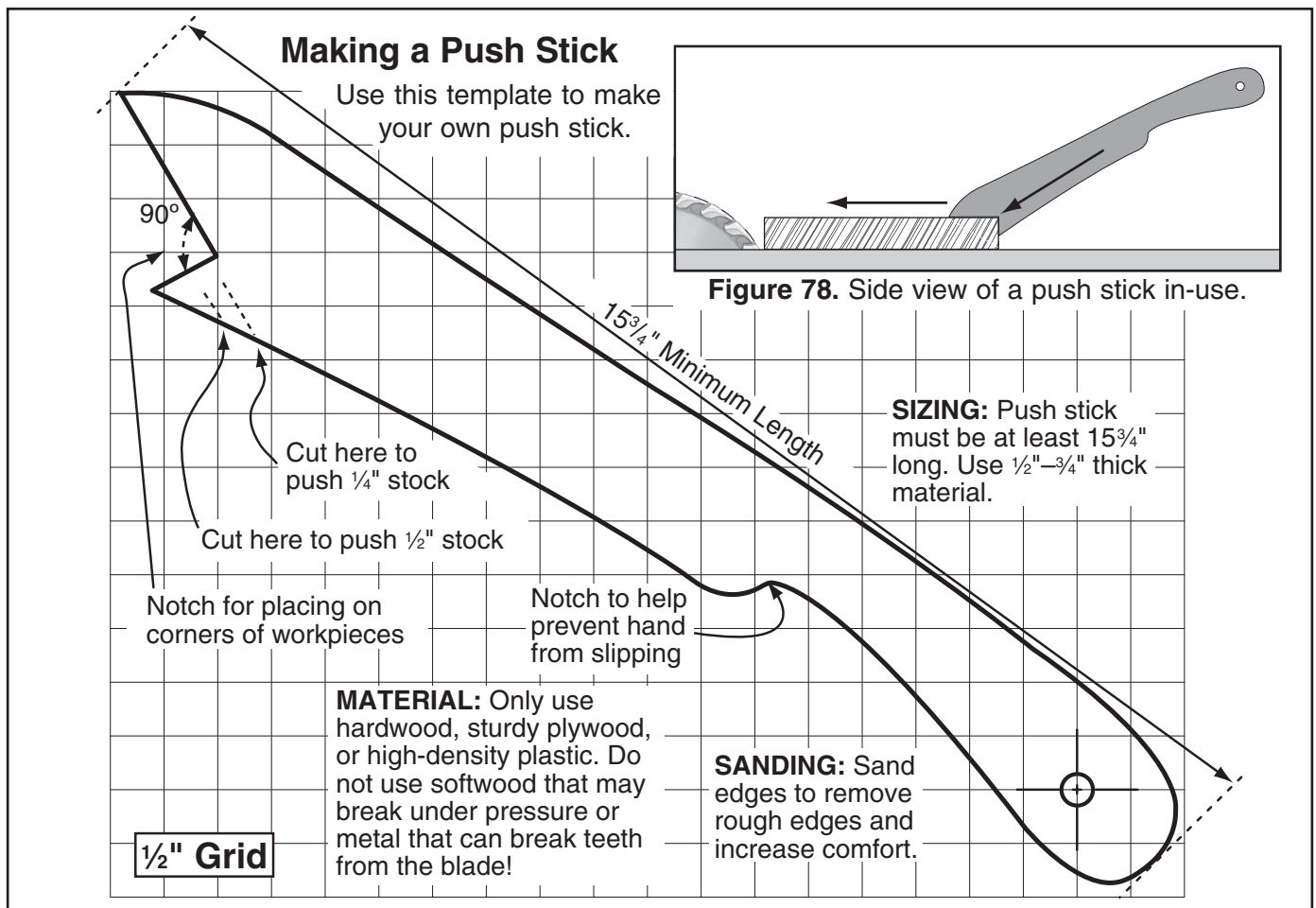

Figure 78. Side view of a push stick in-use.

Figure 79. Template for a basic shop-made push stick (not shown at actual size).



Push Blocks

When used correctly, a push block reduces the risk of injury by keeping hands away from the blade while cutting. In the event of an accident, a push block often takes the damage that would have otherwise happened to hands or fingers.

Using a Push Block

A push block can be used in place of or in addition to a push stick for feeding workpieces into the blade. Due to their design, push blocks allow the operator to apply firm downward pressure on the workpiece that could not otherwise be achieved with a push stick.

The push block design on this page can be used in two different ways (see inset **Figure** below). Typically, the bottom of the push block is used until the end of the workpiece reaches the blade.

The notched end of the push block is then used to push the workpiece the rest of the way through the cut, keeping the operator's hands at a safe distance from the blade. A push stick is often used at the same time in the other hand to support the workpiece during the cut (see "Using a Push Stick" on previous page).

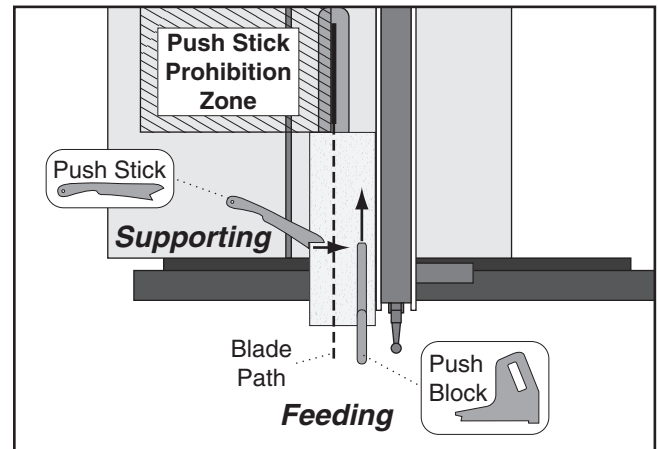

Figure 81. Using a push block and push stick to make a rip cut.

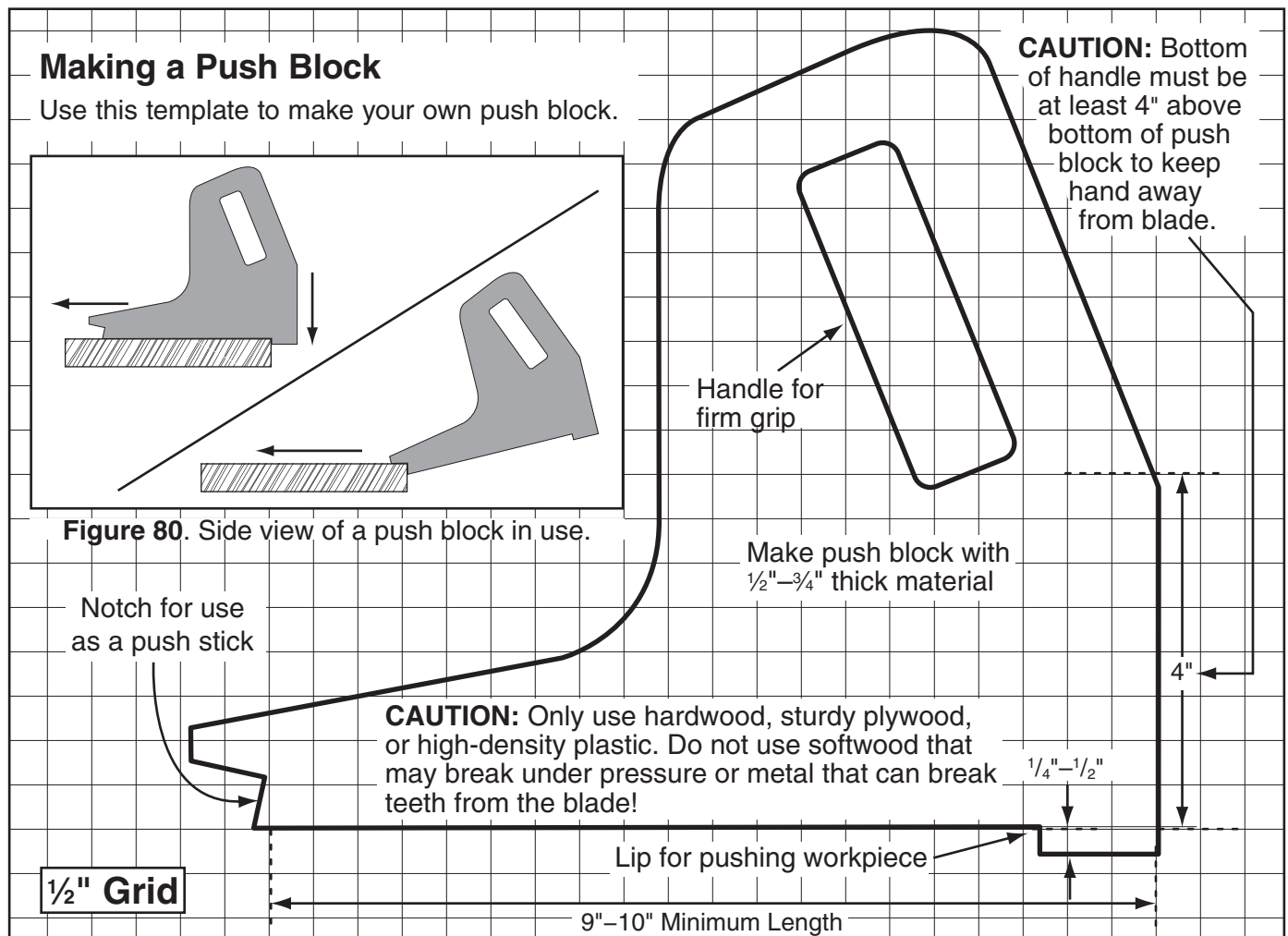

Figure 82. Template for a shop-made push block (shown at 50% of full size).



Narrow-Rip Auxiliary Fence & Push Block

There are designs for hundreds of specialty jigs that can be found in books, trade magazines, and on the internet. These types of jigs can greatly improve the safety and consistency of cuts. They are particularly useful during production runs when dozens or hundreds of the same type of cut need to be made.

The narrow-rip auxiliary fence and push block system shown in this section is an example of a specialty jig that can be made to increase the safety of very narrow rip cuts.

Material Needed for Narrow Rip Auxiliary Fence & Push Block

Hardwood $\frac{3}{4}$ " x 3" x Length of Fence 1
 Plywood $\frac{3}{4}$ " x $5\frac{1}{4}$ " x Length of Fence 1
 Wood Screws #8 x $1\frac{1}{2}$ " 8

Material Needed for Push Block

Hardwood or Plywood $\frac{3}{4}$ " x 15" x $5\frac{5}{8}$ " 1
 Hardwood or Plywood $\frac{3}{4}$ " x 10" x 5"–9" 1
 Cyanoacrylate Wood GlueVaries
 Wood Screws #8 x $1\frac{1}{2}$ "As Needed

Making a Narrow-Rip Push Block for an Auxiliary Fence

1. Cut a piece of $\frac{3}{4}$ " thick plywood $5\frac{1}{4}$ " wide and as long as your table saw fence; cut a piece of $\frac{3}{4}$ " thick hardwood 3" wide and as long as your table saw fence, as shown in **Figure 83**.

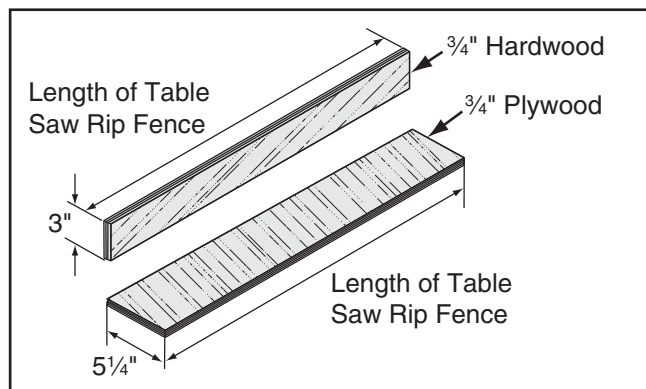

Figure 83. Auxiliary fence dimensions.

Note: We recommend cutting the hardwood board oversize, then jointing and planing it to the correct size to make sure the board is square and flat. Only use furniture-grade plywood or kiln dried hardwood to prevent warping.

2. Pre-drill and countersink eight pilot holes $\frac{3}{8}$ " from the bottom of the 3" wide board, then secure the boards together with eight #8 x $1\frac{1}{2}$ " wood screws, as shown in **Figure 84**.

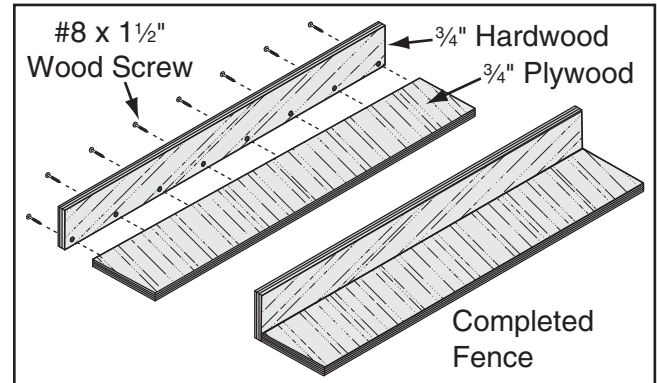

Figure 84. Location of pilot holes.

3. Using the $\frac{3}{4}$ " material you used in the previous steps, cut out pieces for the push block per the dimensions shown in **Figure 85**; for the handle, cut a piece 10" long by 5"–9" high and shape it as desired to fit your hand.

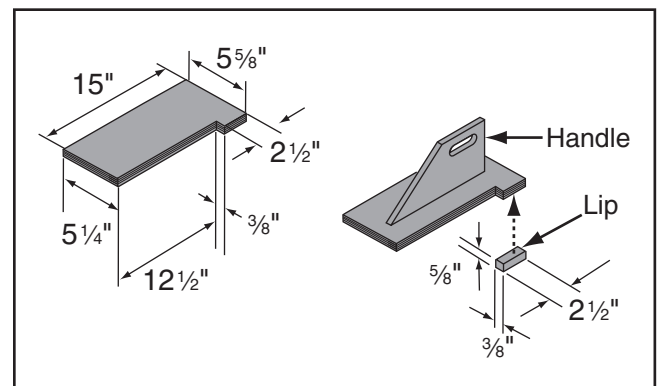

Figure 85. Push block dimensions and construction.

4. Attach the handle to the base with #8 x $1\frac{1}{2}$ " wood screws, and attach the lip to the base with cyanoacrylate type wood glue.



Using the Auxiliary Fence and Push Block

1. Place the auxiliary fence on the table and clamp it to the fence at both ends, then adjust the distance between the auxiliary fence and the blade—this determines how wide the workpiece will be ripped (see **Figure 86**).

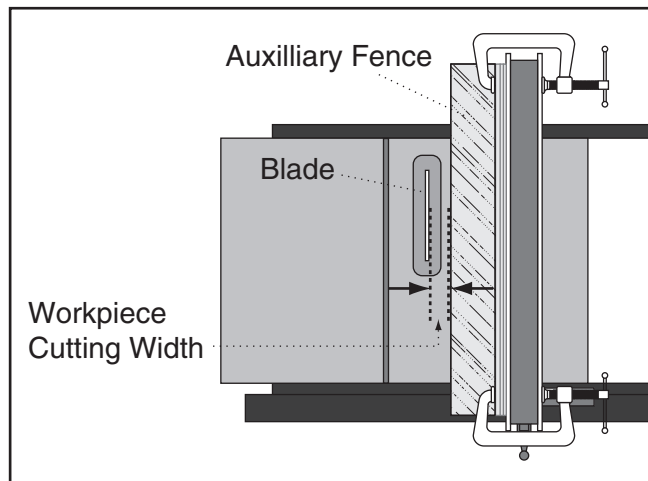

Figure 86. Adjusting ripping distance between blade and auxiliary fence.

2. Install the blade guard, then secure the spreader pawls in the upright position, as shown in **Figure 51** on **Page 38**, so they do not interfere with the push block lip.

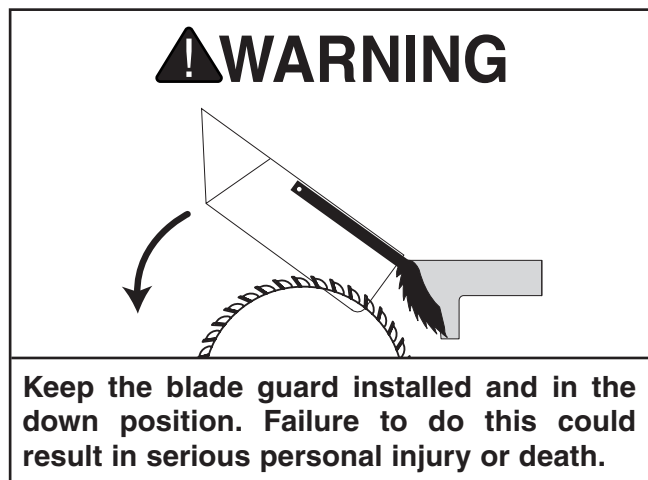

Figure 87. Push block in position to push workpiece through blade.

4. Turn the saw **ON**, then begin ripping the workpiece using a push stick for side support.
5. As the workpiece nears the end of the cut, place the push block on the auxiliary fence with the lip directly behind the workpiece, then release the push stick just before the blade.
6. Guide the workpiece the rest of the way through the cut with the push block, as shown in **Figure 88**.

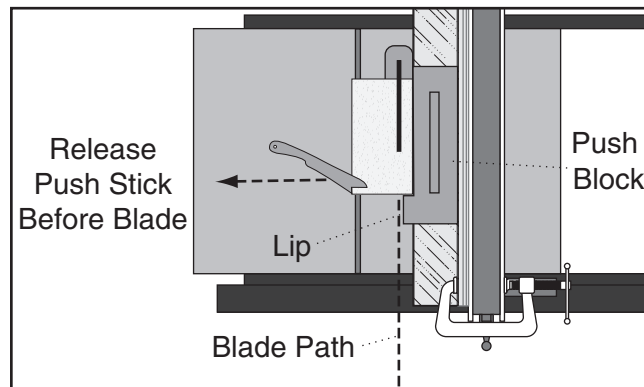

Figure 88. Ripping with push block.

3. Place the workpiece 1" behind the blade and evenly against the table and the auxiliary fence.



WARNING
Keep the blade guard installed and in the down position. Failure to do this could result in serious personal injury or death.

WARNING
Turn **OFF** the saw and allow the blade to come to a complete stop before removing the cut-off piece. Failure to follow this warning could result in serious personal injury.



Outfeed & Support Tables

One of the best accessories for improving the safety and ease of using a table saw is simply placing a large table (outfeed table) behind the saw to catch the workpiece (see **Figure 89**). Additionally, another table to the left of the saw (support table) can also help support large workpieces so they can be cut safely and accurately.



Figure 89. Example of outfeed & support tables.

Crosscut Sled

A crosscut sled (see **Figure 90**) is a fantastic way to improve the safety and accuracy of crosscutting on the table saw. Most expert table saw operators use a crosscut sled when they have to crosscut a large volume of work, because the sled offers substantial protection against kickback when crosscutting.



Figure 90. Example of crosscut sled.



SECTION 6: ACCESSORIES

⚠ WARNING

Installing unapproved accessories may cause machine to malfunction, resulting in serious personal injury or machine damage. To reduce this risk, only install accessories recommended for this machine by Grizzly.

NOTICE

Refer to our website or latest catalog for additional recommended accessories.

H7583—Grizzly Tenoning Jig

Our fully adjustable tenoning jig handles stock up to 3¼" thick and features an adjustable bevel angle with a 90° to 75° range. The two large grip handles, adjustable guide bar, multi-position control levers, and extra large clamping handwheel will ensure accurate and repeatable results. A top seller!

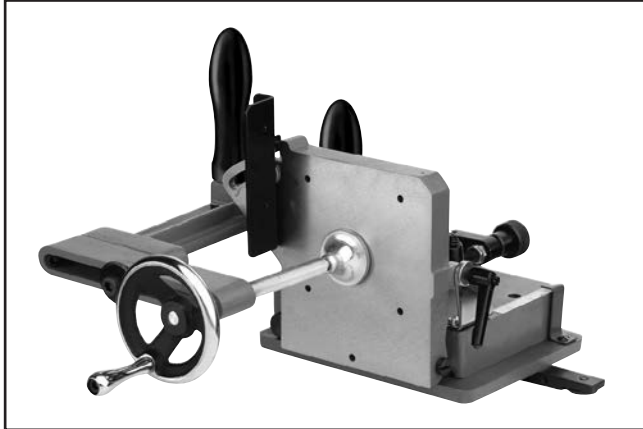

Figure 91. Model H7583 Tenoning Jig.

D2057A—Heavy-Duty Mobile Base

This patented base is the most stable on the market with outrigger type supports. Adjusts from 20" x 20" to 29½" x 29½". 700 lb. capacity. Weighs 34 lbs.



Figure 92. Model D2057A Mobile Base.

D2259A—Extension Kit for D2057A

This kit easily bolts onto Model D2057A to provide support for an extension table or similar device. Allows the whole machine and extension to move as one unit. Adjustable length up to 45¾", and legs can be adjusted front to back. Very versatile!



Figure 93. Model D2259A Extension Kit.

order online at www.grizzly.com or call 1-800-523-4777



T10222—Router Table Attachment

T10223—Sliding Table Attachment

Accessorize your G0690 or G0691 Cabinet Table Saw with either of these attachments for the ultimate in table saw functionality.

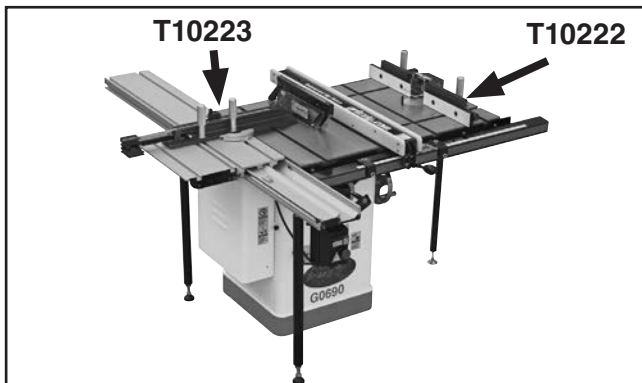

Figure 94. T10222-23 Sliding Table & Router Table Attachments.

Forrest Woodworker II Saw Blades

T20778—10", 20 Teeth

T20779—10", 40 Teeth

T23527—10", 48 Teeth

Hailed as the Cadillac of all blades, Forrest saw blades have become legendary for their ability to leave highly polished, finish-ready surfaces on nearly everything they cut. Made in the USA.

With this all-purpose blade for table saws you can rip and crosscut 1" 2" rockhards and softwoods, resulting in a smooth-as-sanded surface. With 20° face hook, ply veneers will crosscut with no bottom splinter at moderate feed rates. Double hard and 40% stronger C4 carbide will give up to 300% longer life between sharpenings. Ends blade changing (one blade does rip, combo and crosscut), second-step finishing and cutting 1/16" oversize to allow for resurfacing. Buy and sharpen one blade instead of 3 (24T rip, 50T combination and 80T crosscut). 5/8" arbor, 1/8" kerf.



Figure 95. Forrest Woodworker II Saw Blade.

Forrest Dado Blades

H4756—8" x 5/8" 24T Dado Blade Set

T23267—8" x 5/8" 24T 3 Pc. Set

The world's finest dado blades cleancut all your grooves! No splintering when cross-cutting oak, ply veneers and melamine. Perfect for flat-bottomed grooves. No staggered steps or round bottoms like a wobble-dado leaves! Cuts in all directions—rip, cross-cut, miter, any depth. Super-hard carbide gives up to 300% longer life, especially good on plywoods and abrasive particle-boards. 5/8" arbor.



Figure 96. Forrest dado blades.

G0710—1HP Wall-Mount Dust Collector

G0710P—1HP Wall-Mount Dust Collector

G1163P—1HP Floor Model Dust Collector

G3591—30-Micron Replacement Bag

H4340—3.0-Micron Upgrade Bag

Excellent point-of-use dust collectors that can be used next to the machine with only a small amount of ducting. Specifications: 537 CFM, 7.2" static pressure, 2 cubic foot bag, and 30 micron filter. Motor is 1HP, 120V/240V, 7A/3.5A.

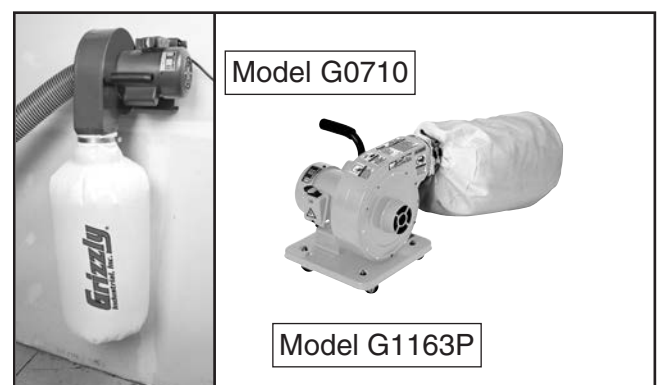

Figure 97. Point-of-use dust collectors.

order online at www.grizzly.com or call 1-800-523-4777



D3096—Featherboard

Designed to lock into a standard $\frac{3}{8}$ " x $\frac{3}{4}$ " miter slot, this featherboard is fully adjustable to accommodate a wide range of workpieces.

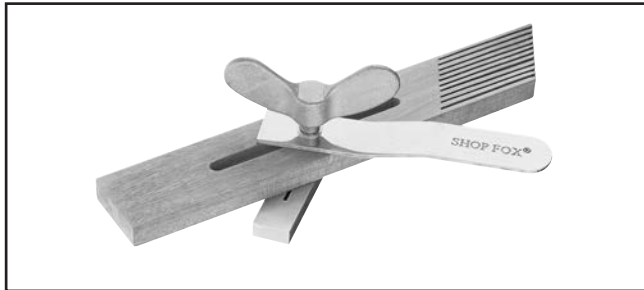

Figure 98. Model D3096 Featherboard.

T20916—Zero Clearance Insert for G0690-91

Made especially for our G0690 and G0691 Table Saws. Height is easily adjustable. Special phenolic material.

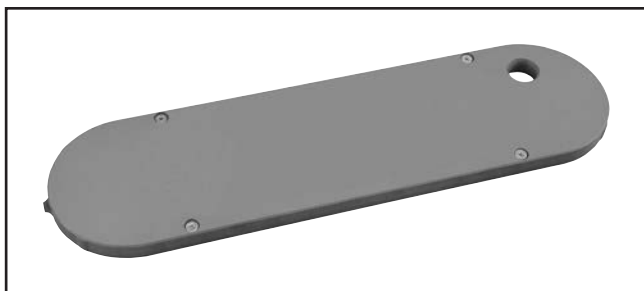

Figure 99. Model T20916 Zero Clearance Insert.

T22977—The Missing Shop Manual: Tablesaw

In addition to explaining the basics of safety and setup, this handy reference will help you get the most for your money by getting the most from your equipment. From cutting dados and molding to creating jigs, you'll discover the techniques and tips you need to maximize your table saw's performance. Even if you've been woodworking for years, you'll wish this was the manual that originally came with your new table saw. 144 pgs.

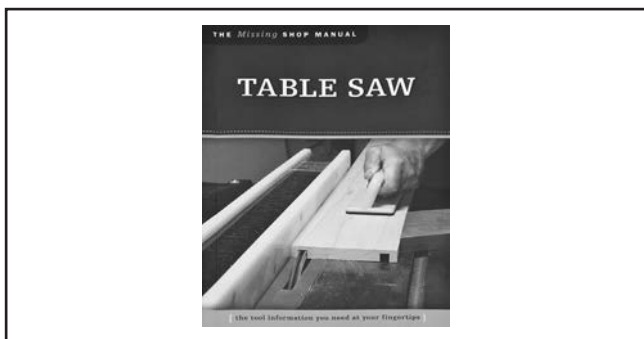

Figure 100. Model T22977 The Missing Shop Manual: Tablesaw.

D4206—Clear Flexible Hose 4" x 10'

D4256—45° Elbow 4"

D4216—Black Flexible Hose 4" x 10'

W1034—Heavy-Duty Clear Flex Hose 4" x 10'

D2107—Hose Hanger 4 $\frac{1}{4}$ "

W1015—Y-Fitting 4" x 4" x 4"

W1017—90° Elbow 4"

W1019—Hose Coupler (Splice) 4"

W1317—Wire Hose Clamp 4"

W1007—Plastic Blast Gate 4"

W1053—Anti-Static Grounding Kit

We've hand picked a selection of commonly used dust collection components for machines with 4" dust ports.



Figure 101. Dust collection accessories.

G1317—37" Outfeed Roller System

This unique roller system folds down easily without tools and snaps up in place quickly when needed. Has a double level system which lets you set the rollers either in line with the table or slightly below it.

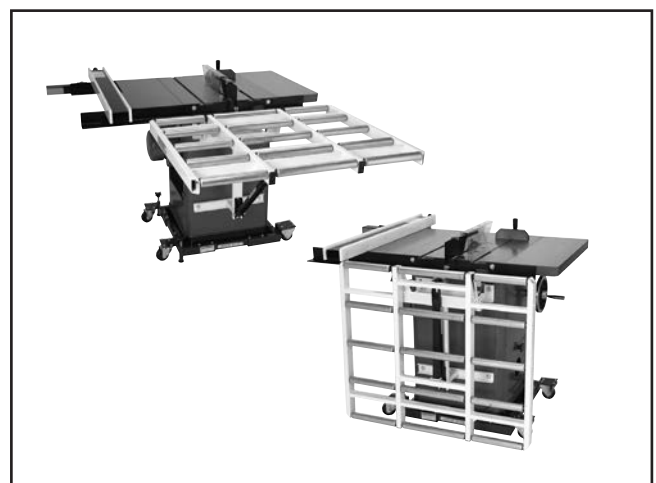

Figure 102. G1317 Outfeed Roller System

order online at www.grizzly.com or call 1-800-523-4777



SECTION 7: MAINTENANCE



Schedule

For optimum performance from your machine, follow this maintenance schedule and refer to any specific instructions given in this section.

Daily Check:

- Inspect blades for damage or wear.
- Check for loose mounting bolts/arbor nut.
- Check cords, plugs, and switch for damage.
- Check for any other condition that could hamper the safe operation of this machine.
- Wipe the table clean after every use—this ensures moisture from wood dust does not remain on bare metal surfaces.

Weekly Maintenance:

- Wipe down the table surface and grooves with a lubricant and rust preventive such as SLIPIT®.
- Vacuum dust buildup from the motor housing and trunnions.
- Clean the pitch and resin from the saw blade with a cleaner like OxiSolv® Blade & Bit Cleaner.

Monthly Maintenance:

- Check/tighten the belt tension (**Page 73**).

Cleaning

Cleaning the Model G0690/G0691 is relatively easy. Vacuum excess wood chips and sawdust, and wipe off the remaining dust with a dry cloth. If any resin has built up, use a resin dissolving cleaner to remove it.

After cleaning, treat all unpainted cast iron and steel with a non-staining lubricant.

Occasionally it will become necessary to clean the internal parts with more than a vacuum. To do this, remove the table top and clean the internal parts with resin/pitch dissolver or mineral spirits and a stiff wire brush or steel wool. **DO NOT USE WATER—WATER WILL CAUSE CAST IRON TO RUST.**

Make sure the internal workings are dry before using the saw again, so that wood dust will not accumulate. If any essential lubrication is removed during cleaning, re-lubricate those areas.



Lubrication

An essential step for lubrication is cleaning the components before lubricating them.

This idea is critical because dust and chips build up on lubricated components and make the components hard to move. Simply adding more grease to the components with built-up grime on them will not yield smooth moving components.

Clean the components in this section with an oil/grease solvent cleaner.

If you thoroughly clean the components in this section before lubricating them, the result will be silky smooth movement when turning the handwheels, which will result in much higher enjoyment on your part!

The following are the main components that need to be lubricated:

- Trunnion Slides and Orientation Gears
- Worm Gears, Trunnion and Bearing Housing Teeth

Trunnion Slides & Orientation Gears

Clean the trunnion slides out with mineral spirits and a rag, and brush a dollop of lithium grease into each groove. Move the blade tilt back-and-forth to spread the grease (see **Figure 103**).

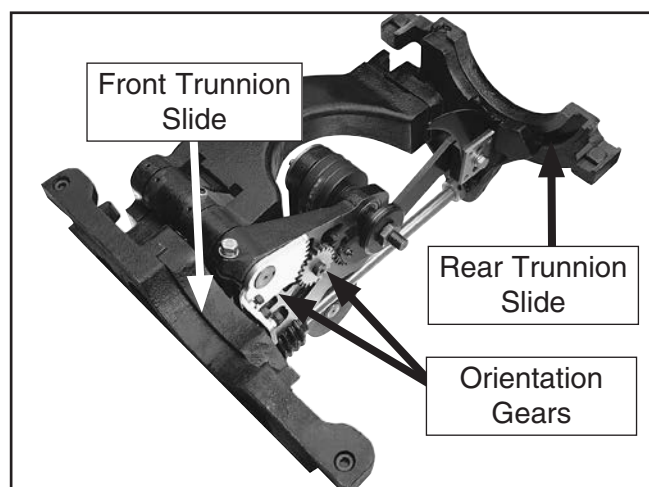

Figure 103. Trunnion slides and tilt leadscrew.

Also use a wire brush and mineral spirits to clean any debris or grime off the orientation gears, then apply lithium grease to the gears with a brush.

Worm Gears, Trunnion and Bearing Housing Teeth

Clean away any built up grime and debris with a wire brush and mineral spirits from the worm gears and the teeth on the bearing housing and trunnion. Then use a brush or rag to apply a thin coat of white lithium grease to the gears and teeth.

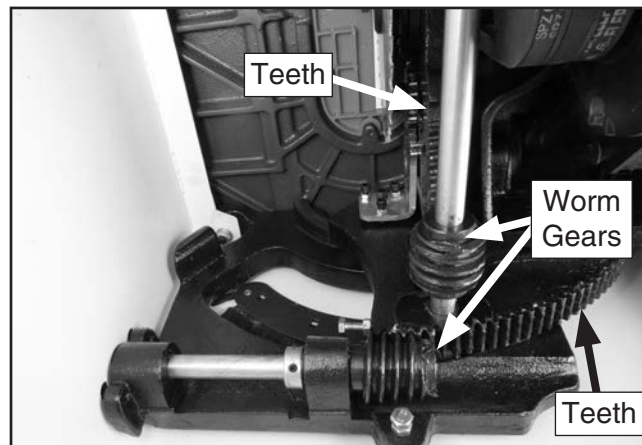

Figure 104. Worm gears and teeth.



SECTION 8: SERVICE

Review the troubleshooting procedures in this section if a problem develops with your machine. If you need replacement parts or additional help with a procedure, call our Technical Support. **Note:** *Please gather the serial number and manufacture date of your machine before calling.*

Troubleshooting

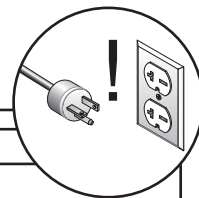

Symptom	Possible Cause	Possible Solution
Machine does not start or a breaker trips.	<ol style="list-style-type: none"> 1. Locking pin installed. 2. Blown fuse. 3. Power supply switched OFF or at fault. 4. Plug/receptacle at fault/wired wrong. 5. Motor connection wired wrong. 6. Wall circuit breaker tripped. 7. Wiring open/has high resistance. 8. Motor ON/OFF switch at fault. 9. Start capacitor at fault. 10. Motor at fault. 	<ol style="list-style-type: none"> 1. Remove locking pin from ON button. 2. Replace fuse/ensure no shorts. 3. Ensure power supply is on/has correct voltage. 4. Test for good contacts; correct the wiring. 5. Correct motor wiring connections. 6. Ensure circuit size is correct/replace weak breaker. 7. Check/fix broken, disconnected, or corroded wires. 8. Replace switch. 9. Test/replace if faulty. 10. Test/repair/replace.
Machine stalls or is underpowered.	<ol style="list-style-type: none"> 1. Feed rate/cutting speed too fast. 2. Workpiece material unsuitable for machine. 3. Workpiece crooked; fence mis-adjusted. 4. Machine undersized for task. 5. Run capacitor at fault. 6. Belt slipping. 7. Motor wired incorrectly. 8. Plug/receptacle at fault. 9. Pulley/sprocket slipping on shaft. 10. Motor bearings at fault. 11. Contactor not energized/has poor contacts. 12. Motor overheated. 13. Motor at fault. 	<ol style="list-style-type: none"> 1. Decrease feed rate/cutting speed. 2. Only cut wood/ensure moisture is below 20%. 3. Straighten or replace workpiece/adjust fence. 4. Use correct blade/reduce feed rate or depth of cut. 5. Test/repair/replace. 6. Tension/replace belt (Page 73). 7. Wire motor correctly. 8. Test for good contacts/correct wiring. 9. Replace loose pulley/shaft. 10. Test/repair/replace. 11. Test all legs for power/replace if faulty. 12. Clean motor, let cool, and reduce workload. 13. Test/repair/replace.
Machine has vibration or noisy operation.	<ol style="list-style-type: none"> 1. Motor or component loose. 2. Blade at fault. 3. Belts worn or loose. 4. Pulley loose. 5. Motor mount loose/broken. 6. Machine incorrectly mounted. 7. Arbor pulley loose. 8. Motor fan rubbing on fan cover. 9. Arbor bearings at fault. 10. Motor bearings at fault. 	<ol style="list-style-type: none"> 1. Inspect/replace damaged bolts/nuts, and re-tighten with thread locking fluid. 2. Replace warped/bent blade; sharpen dull blade. 3. Tension/replace belts (Page 73). 4. Realign/replace shaft, pulley, setscrew, and key. 5. Tighten/replace. 6. Tighten mounting bolts; relocate/shim machine. 7. Retighten/replace arbor pulley. 8. Fix/replace fan cover; replace loose/damaged fan. 9. Replace arbor housing bearings; replace arbor. 10. Test by rotating shaft; grinding/loose shaft requires bearing replacement.



Symptom	Possible Cause	Possible Solution
Blade is not aligned with miter slot or fence.	<ol style="list-style-type: none"> 1. Blade is warped. 2. Table top is not parallel to blade. 3. Fence is not parallel to blade. 	<ol style="list-style-type: none"> 1. Replace blade (Page 36). 2. Make table parallel to blade (Page 67). 3. Make fence parallel to blade (Page 69).
Blade does not reach 90°.	<ol style="list-style-type: none"> 1. 90° stop bolt is out of adjustment. 2. Sawdust stuck on stop bolt. 	<ol style="list-style-type: none"> 1. Adjust 90° stop bolt (Page 65). 2. Clean sawdust off stop bolt.
Blade hits insert at 45°.	<ol style="list-style-type: none"> 1. 45° stop bolt is out of adjustment. 2. Sawdust stuck on stop bolt. 3. Hole in insert is inadequate. 4. Table out of alignment. 5. Blade position is incorrect. 	<ol style="list-style-type: none"> 1. Adjust 45° stop bolt (Page 65). 2. Clean sawdust off stop bolt. 3. File or mill the hole in the insert. 4. Align blade to the table (Page 67). 5. Adjust blade position.
Board binds or burns when feeding through table saw.	<ol style="list-style-type: none"> 1. Dull blade. 2. Blade is warped. 3. Fence is not parallel to blade. 4. Table top is not parallel to blade. 	<ol style="list-style-type: none"> 1. Replace blade. 2. Replace blade (Page 36). 3. Make fence parallel to blade (Page 69). 4. Make table parallel to blade (Page 67).



Blade Tilt Stops

The table saw features stop bolts that stop the blade exactly at 45° and 90° when tilting it with the handwheel. The stops have been set at the factory and should require no adjustments, unless you notice that your cuts are not accurate.

Note: The tilt scale reads "0" when the blade is 90° to the table.

Tools Needed	Qty
90° Square	1
45° Square	1
Hex Wrench 3mm.....	1
Wrench 10mm	1
Wrench 13mm	1

Setting 90° Stop Bolt

1. DISCONNECT THE SAW FROM POWER!
2. Raise the blade as high as it will go, then tilt it toward 0° until it stops and cannot be tilted any more.
3. Place a 90° square against the table and blade so it contacts the blade evenly from bottom to top, as shown in **Figure 105**. Make sure a blade tooth does not obstruct the placement of the square.

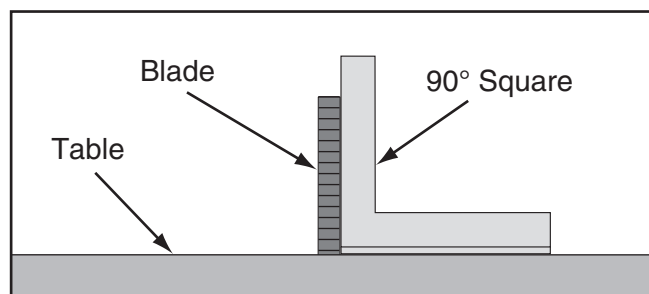

Figure 105. Checking blade at 90°.

—If the blade is 90° to the table, then adjustments do not need to be made. Make sure the tilt indicator arrow shown in **Figure 106** points to the 0° mark on the scale. Adjust the position by loosening the button head screw, moving the indicator with your fingers, then tightening the screw.

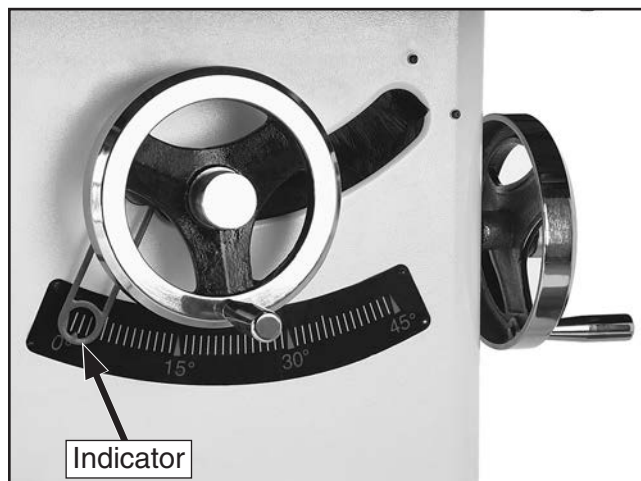

Figure 106. Tilt indicator arrow.

—If the blade is not 90° to the table, you will need to adjust the 90° stop screw. Proceed to the next step.

4. Tilt the blade away from 0° by about 5°, so there is room for the stop bolt to move.
5. Open the motor access cover, loosen the jam nut shown in **Figures 107** and **108**, adjust the stop bolt up or down according to how far off the blade was from 90°, then repeat **Steps 2-3** until the blade stops at 90°.

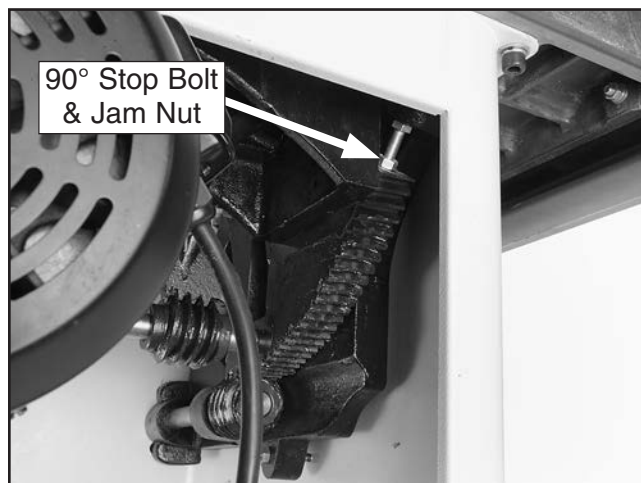

Figure 107. 90° stop bolt and jam nut.



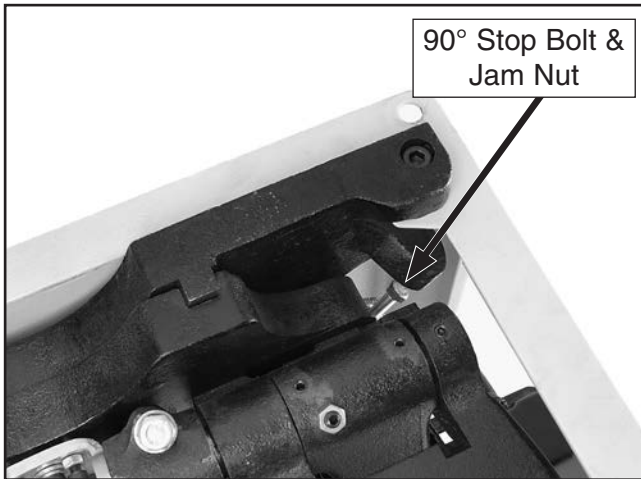

Figure 108. 90° stop bolt and jam nut (table removed for clarity).

6. Tighten the jam nut, then close the motor cover.

Setting 45° Stop Bolt

1. DISCONNECT THE SAW FROM POWER!
2. Raise the blade as high as it will go, then tilt it towards 45° until it stops and cannot be tilted any more.
3. Place a 45° square against the table and blade so it contacts the blade evenly from bottom to top, as shown in **Figure 109**. Make sure a blade tooth does not obstruct the placement of the square.

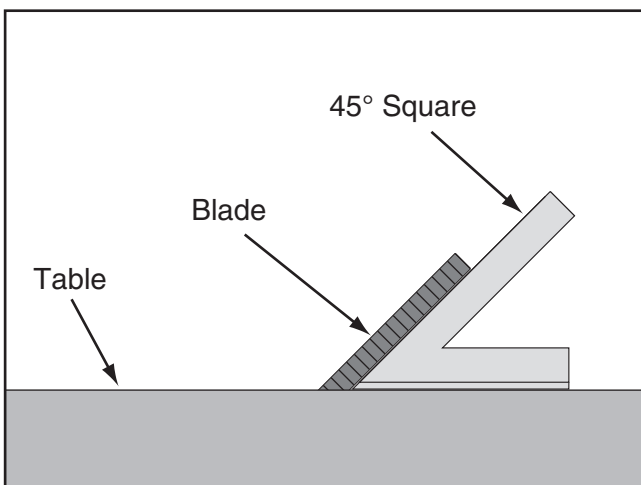

Figure 109. Checking blade at 45°.

—If the blade is 45° to the table, then adjustments do not need to be made.

—If the blade is not 45° to the table, you will need to adjust the 45° stop screw. Proceed to the next step.

4. Tilt the blade to 15°, so there is room for the stop bolt to move.
5. Remove the dust port to access the stop bolt.
6. Loosen the jam nut on the 45° stop bolt (see **Figure 110**) with a 13mm wrench, adjust the stop bolt up or down according to how far off the blade was from 45°.

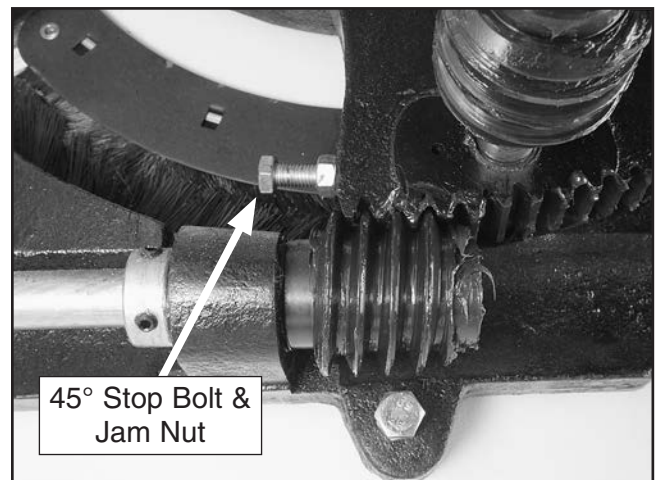

Figure 110. 45° stop bolt and jam nut.

7. Continue adjusting the stop bolt until it contacts the cabinet when the blade is at 45°, then tighten the jam nut.
8. Close the dust port.



Miter Slot to Blade Parallelism

Tools Needed	Qty
Adjustable Square	1
Metal Shim Stock	As Needed
Marker	1

Your table saw will give the best results if the miter slot and the rip fence are adjusted parallel to the blade. If either of these are not exactly parallel, your cuts and your finished work will be lower in quality, but more importantly, the risk of kickback will be increased. Take the time to adjust your table saw properly. A few minutes now will be time well spent.

To adjust the blade parallel to the miter slot:

1. DISCONNECT THE SAW FROM POWER!
2. Use an adjustable square to measure the distance from the miter slot to a carbide tip on the blade, as shown in **Figure 111**. Make sure that the face of the adjustable square is even along the miter slot.

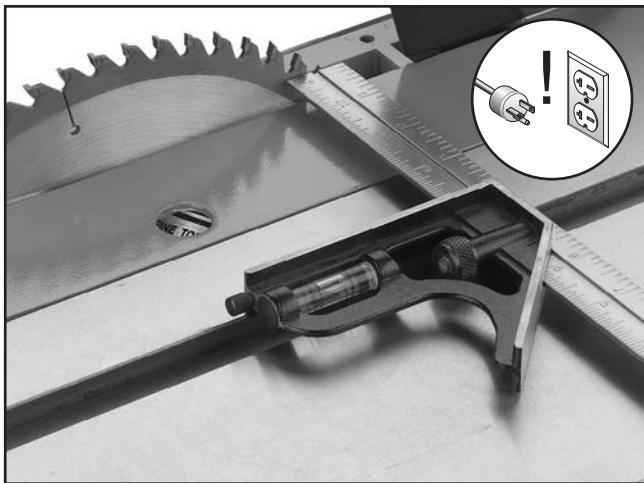

Figure 111. Example of adjusting blade to miter slot.

3. With the end of the adjustable square just touching the tip, lock the square in place. Now, mark the carbide tip with a marker where you made this measurement.

⚠ CAUTION

The saw blade is dangerously sharp. Use extra care or wear gloves when handling the blade or working near it.

4. Rotate the marked blade tip to the other end of the table insert.
5. Slide the adjustable square down to the other end of the table insert, and compare the distance from the marked blade tip to the end of the adjustable square.

—If the blade tip does not touch the end of the adjustable square similar to the first measurement, the table will need to be adjusted. Proceed to **Step 6**.

—If the blade tip measurement is the same on both sides, go to **Step 7**.

6. To adjust the table, loosen the four cap screws in the table mounting locations (see **Figure 112**) and slightly tap the table in the needed direction. Repeat **Steps 2–5** until the blade and miter slot are parallel.
7. Tighten the table mounting cap screws in a criss-cross, alternating manner.

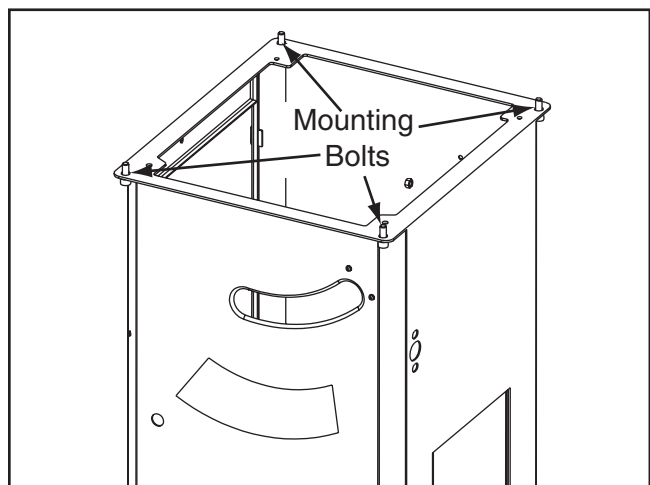

Figure 112. Table mounting bolts.



Spreader or Riving Knife Alignment

Checking Alignment

The blade guard spreader and riving knife must be aligned with the blade when installed. If the spreader/riving knife is not aligned with the blade, then the workpiece will be forced sideways during the cut, which will increase the risk of kick-back.

Tools Needed	Qty
Straightedge	1

To check the spreader/riving knife alignment:

1. DISCONNECT THE SAW FROM POWER!
2. Raise the saw blade to the maximum height so you have easy working access.
3. Place the straightedge against the top and bottom of blade and spreader/riving knife, as shown in **Figure 113**. The spreader/riving knife should be parallel with the blade along its length at both positions, and it will be in the "Alignment Zone," as shown in **Figure 114**.

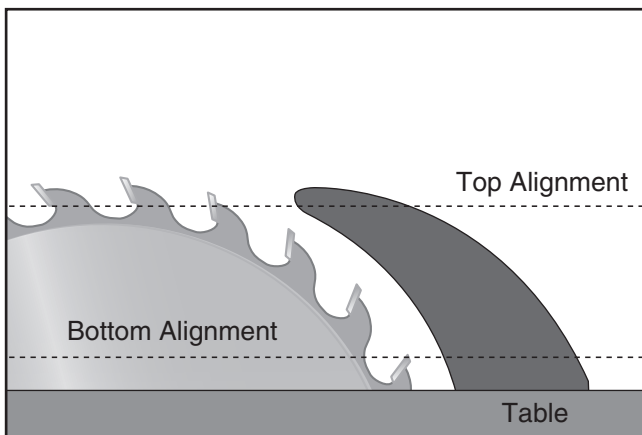

Figure 113. Checking top and bottom riving knife parallelism with blade.

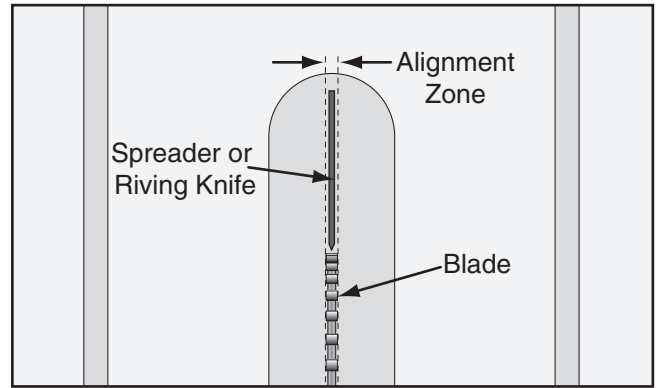

Figure 114. Spreader/riving knife alignment zone.

—If the spreader/riving knife is not parallel with the blade and inside the alignment zone, then it needs to be adjusted. Proceed to **Adjusting Alignment** instructions.

—If the spreader/riving knife is not parallel with the blade at either the top or bottom, it may be bent.

4. Remove the spreader/riving knife and place it on a flat surface and check to see if the spreader/riving knife lays evenly along its length.

—If the spreader/riving knife does not lay evenly, proceed to **Adjusting Bent Spreader/Riving Knife** on **Page 69**.

Adjusting Alignment

The spreader/riving knife mounting position can be adjusted into alignment with the blade using the set screws on the spreader/riving knife mounting block.

Possible Tools Needed	Qty
Hex Wrench 3mm.....	1
Hex Wrench 5mm.....	1

To adjust the spreader/riving knife position:

1. DISCONNECT THE SAW FROM POWER!
2. Remove the table insert.



- Loosen the two cap screws on the mounting block, then adjust either the top or bottom control set screws or side control set screws (see **Figure 115**) to move it the needed direction.

- Reinstall the table insert.
- Follow **Checking Alignment, Steps 1–3**.
 - If the spreader/riving knife is in the alignment zone, no additional steps are necessary.
 - If the spreader/riving knife is still not in the alignment zone, continue adjusting the set screws on the mounting block as necessary to correctly position the spreader/riving knife.
- Tighten the two cap screws on the mounting block to secure the spreader/riving knife adjustment.

Adjusting Bent Spreader/Riving Knife

- DISCONNECT THE SAW FROM POWER!
- Bend the spreader or riving knife by hand while installed, then follow **Steps 1–3 in Checking Alignment** to determine if it is parallel with the blade and inside the "Alignment Zone" (refer to **Checking Alignment**).
 - If this doesn't work, remove it to straighten.
 - If you cannot straighten it properly, replace it.

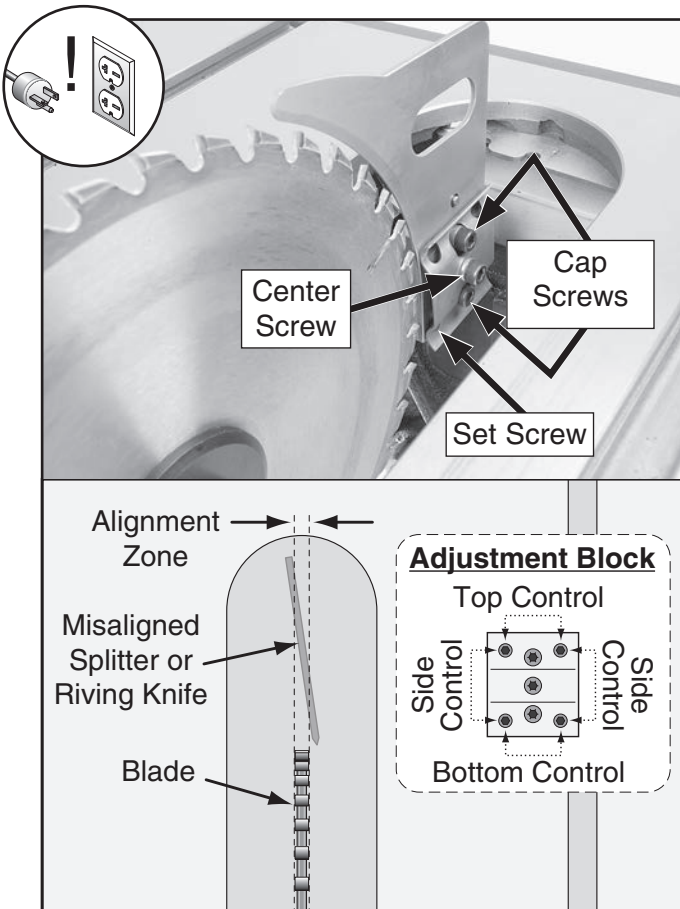

Figure 115. Set screws for adjusting spreader/riving knife position.

Top and Bottom Control: To move the top of the spreader/riving knife right or left (and the bottom of the spreader/riving knife in the opposite direction), adjust the top and bottom pair of set screws on the mounting block an equal amount in the opposite direction.

Side Control: To move the front of the spreader/riving knife left or right (and the rear of the spreader/riving knife in the opposite direction), adjust each pair of side control set screws an equal amount in the opposite direction.

Note: To adjust how tightly the mounting block holds the spreader/riving knife, adjust the center screw.

Fence Adjustments

There are four main adjustments for the fence: square, height, parallelism, and clamping pressure. Keep in mind that these adjustments are interconnected and some trial-and-error may be needed to achieve satisfactory results.

Tools Needed	Qty
Hex Wrench 6mm.....	1
Square.....	1
Felt-Tipped Marker	1

Square and Height

The fence face must be square to the table in order to produce square cuts. Also, the fence should be adjusted high enough off the table that it does not drag across the surface.



To check/adjust the fence height and squareness to the table:

1. DISCONNECT THE SAW FROM POWER!
2. Place a square on the table against the face of the fence (**Figure 116**) to check if the fence is square to the table.

—If the fence is not square to the table, proceed to **Step 3**.

—If the fence is square to the table, skip ahead to **Step 4**.

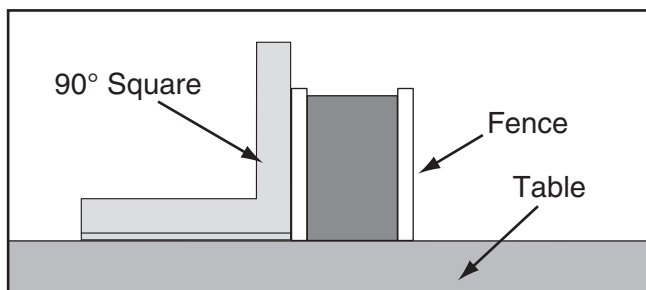

Figure 116. Checking if fence is square to table.

3. Adjust the set screws (**Figure 117**) on top of the fence bracket to ensure the fence face is 90° to the table, then tighten the knurled lock nuts.

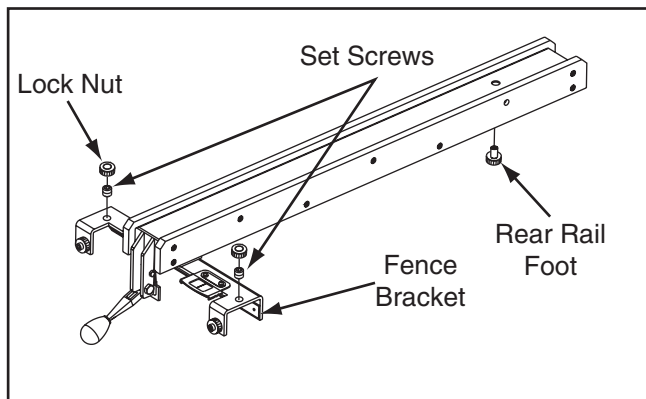

Figure 117. Fence components used to adjust fence height and squareness to table.

4. Look at the gap between the fence and the table top.

—If the gap is approximately $\frac{1}{16}$ " and even from the front of the table to the back, then no additional adjustments are necessary.

—If the gap is uneven, if the fence height is more than $\frac{1}{8}$ ", or if the fence touches the table, then continue with **Step 5**.

5. Adjust the fence height with the rear rail foot until the gap between the table and the fence is approximately $\frac{1}{16}$ " and even from the front of the table to the back.

Note: If the front end of the fence needs to be adjusted up or down, use the set screws from **Figure 117**; however, turn them in even increments and recheck the squareness afterwards.

Clamping Pressure and Parallelism

Set screws on the rear side of the fence bracket adjust the clamping pressure to hold your fence securely, and position the fence parallel to the blade.

To adjust the fence clamping pressure and parallelism to the blade:

1. DISCONNECT THE SAW FROM POWER!
2. Remove the fence.
3. Equally adjust the set screws shown in **Figure 118** on the rear side of the front bracket as necessary until the clamping pressure is strong enough that the fence will not move as pressure is applied against it.

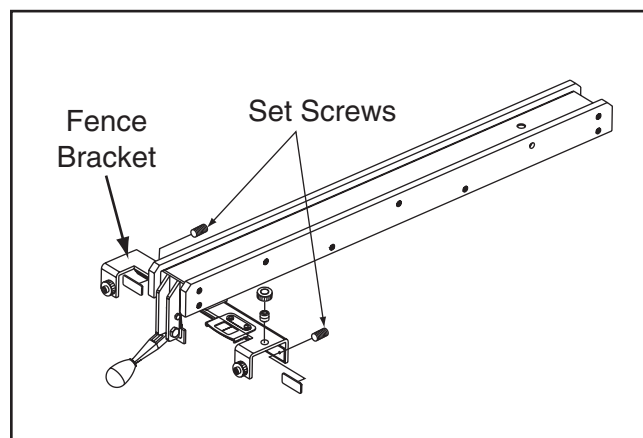

Figure 118. Location of set screws used to adjust fence parallelism and clamping pressure.

4. Place the fence approximately 4" away from the blade.



5. Measure the distance between the fence and the front of the blade at one end of the table insert, then mark the tooth that you measured from with a felt-tipped marker.
6. Rotate the blade to the other end of the table insert (**Figure 119**), and recheck the distance between the fence and the blade to ensure they are parallel.

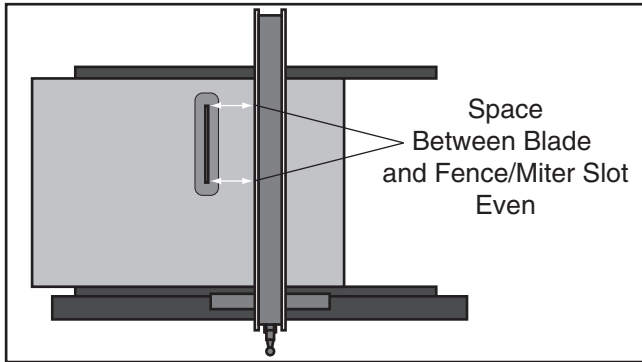

Figure 119. Example of fence aligned parallel to miter slot.

7. Use trial-and-error to adjust the set screws so the fence is parallel to the blade and the clamping pressure is sufficient.

Optional: Some woodworkers prefer to offset the rear of the fence $\frac{1}{64}$ " from the blade, as shown in **Figure 120**, to help prevent the workpiece from binding and burning.

The argument is that this offset adjustment reduces the chance of kickback by alleviating potential binding that may occur between the backside of the blade and fence. The trade-off is slightly less accurate cuts.

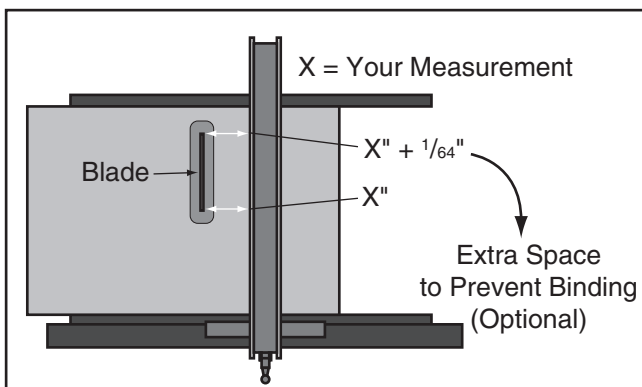

Figure 120. Adjusting fence with a $\frac{1}{64}$ " offset.

Fence Scale Calibration

The fence scale indicator window, shown in **Figure 121**, can be calibrated with the fence scale if you notice that your cuts do not accurately match what is shown on the fence scale.

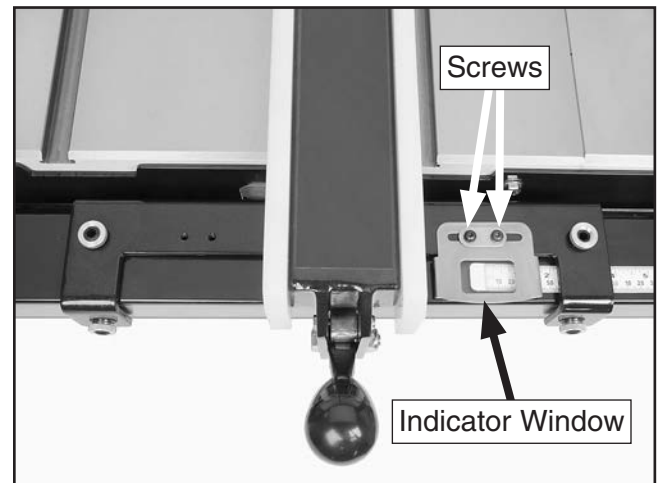

Figure 121. Fence indicator window.

The indicator adjusts by loosening the two mounting screws and sliding it in the desired direction.

Tools Needed	Qty
Hex Wrench 2.5mm.....	1
Scrap Piece of Wood.....	1

To calibrate the fence scale indicator windows:

1. Position and lock the fence at 13", as indicated by the scale, cut your scrap piece of wood.
2. Reposition and lock the fence at 12", as indicated by the scale.
3. Flip your scrap piece of wood over, placing the side that was cut in **Step 2** against the fence, and cut your scrap piece of wood.
4. Measure the width of the freshly cut workpiece with a tape measure. The workpiece width should be exactly 12". If it is not, then adjust the indicator window to match the width of the workpiece.



Miter Gauge Adjustments

The miter gauge can be adjusted so it is perpendicular to the blade and snug in the T-slot.

Tools Needed	Qty
90° Square	1
45° Square	1
Hex Wrench 2.5mm.....	1
Hex Wrench 2mm.....	1
Hex Wrench 3mm.....	1

Checking/Setting 90° Stops

1. DISCONNECT THE SAW FROM POWER!
2. Slide the miter gauge into the T-slot on the table.
3. Loosen the miter gauge lock knob, pull out the positive stop knob, then pivot the miter gauge body to 90° so the stop knob springs into position.
4. Place the square evenly against the face of the miter gauge and the blade, as shown in **Figure 122**.

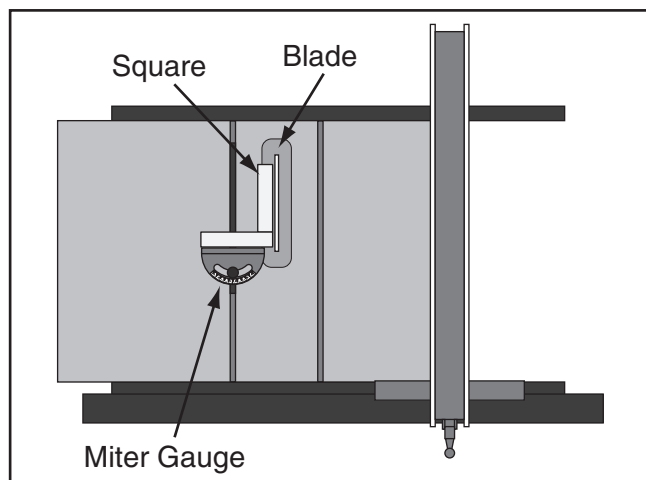

Figure 122. Checking 90° stop on miter gauge.

—If the square touches the miter body and the body of the blade (not the teeth) evenly at the same time, then it is square to the blade and the 90° stop is set correctly. No further adjustments are necessary.

—If the square does not touch the miter body and blade body evenly at the same time, then proceed to **Step 5**.

5. Loosen the button head cap screws on the positive stop knob block (see **Figure 123**), adjust the miter body until it is flush with the square, then tighten the screws.



Figure 123. Screws for adjusting miter gauge body.

6. Loosen the screw on the front of the miter bar, adjust the pointer to 0°, then tighten the screw.

Adjusting Miter Bar Tightness

The miter bar can be adjusted so it fits more tightly in the miter slot.

To adjust the miter bar tightness:

1. Loosen the cap screw on each guide block (**Figure 124**), adjust the set screws as needed, then tighten the cap screw.

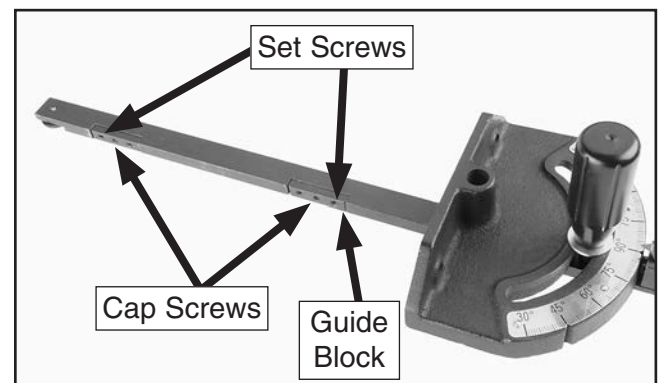

Figure 124. Screws for adjusting miter bar in miter slot.



Belt Tension & Replacement

The three V-belts stretch slightly as the saw is used. Most of the belt stretching will happen during the first 16 hours of use, but it may continue in small increments through continued use.

Tools Needed	Qty
Wrenches 18mm	2

Tensioning Belt

1. DISCONNECT THE SAW FROM POWER!
2. Lower the blade completely, then open the motor cabinet.
3. Loosen the hex nuts on the motor shown in **Figure 125**, and pivot the motor up and down to make sure that it is movable.

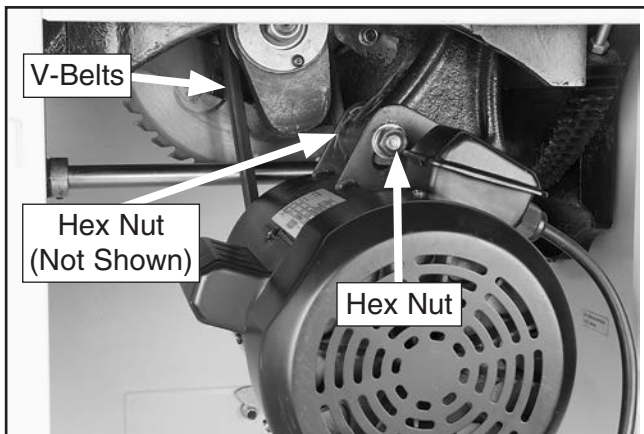

Figure 125. Motor mounting nut.

4. Press down on the motor with one hand to keep the belt tension tight and tighten the hex nuts.
5. Press each V-belt in the center to check belt tension.

The belts are correctly tensioned when there is approximately $\frac{1}{2}$ " deflection when they are pushed with moderate pressure, as shown in **Figure 126**.

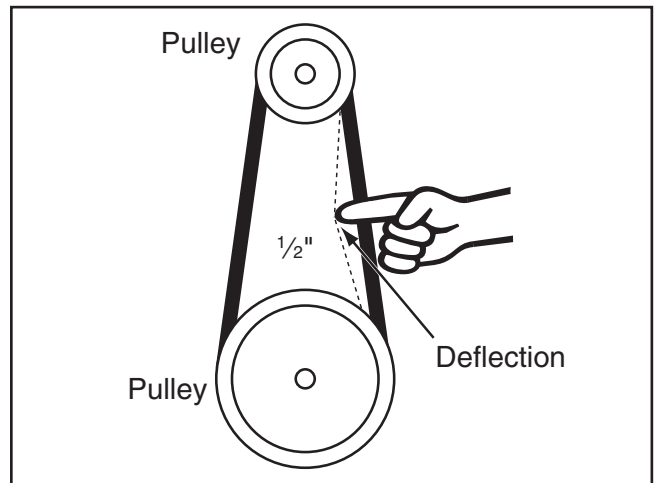

Figure 126. Checking belt tension.

—If there is more than $\frac{1}{2}$ " deflection when the V-belts are pushed with moderate pressure, loosen the hex nuts, adjust the motor downward, then tighten the hex nuts.

6. Close the motor access cover.

Replacing Belt

1. DISCONNECT THE SAW FROM POWER!
2. Lower the blade completely, then open the motor access cover.
3. Loosen the hex nuts that secure the motor (see **Figure 125**) and raise the motor fully to remove tension on the V-belts. Roll the V-belts off of the arbor and motor pulleys.
4. While continuing to raise the motor, install a new matching set of V-belts onto the pulleys, lower the motor to tension the V-belts, then tighten the hex nuts.
5. Follow **Step 5** in the **Tensioning Belt** subsection to check V-belt tension.
6. Close the motor access cover.



SECTION 9: WIRING

These pages are current at the time of printing. However, in the spirit of improvement, we may make changes to the electrical systems of future machines. Compare the manufacture date of your machine to the one stated in this manual, and study this section carefully.

If there are differences between your machine and what is shown in this section, call Technical Support at (570) 546-9663 for assistance BEFORE making any changes to the wiring on your machine. An updated wiring diagram may be available. **Note:** *Please gather the serial number and manufacture date of your machine before calling. This information can be found on the main machine label.*

WARNING

Wiring Safety Instructions

SHOCK HAZARD. Working on wiring that is connected to a power source is extremely dangerous. Touching electrified parts will result in personal injury including but not limited to severe burns, electrocution, or death. Disconnect the power from the machine before servicing electrical components!

MODIFICATIONS. Modifying the wiring beyond what is shown in the diagram may lead to unpredictable results, including serious injury or fire. This includes the installation of unapproved after-market parts.

WIRE CONNECTIONS. All connections must be tight to prevent wires from loosening during machine operation. Double-check all wires disconnected or connected during any wiring task to ensure tight connections.

CIRCUIT REQUIREMENTS. You MUST follow the requirements at the beginning of this manual when connecting your machine to a power source.

WIRE/COMPONENT DAMAGE. Damaged wires or components increase the risk of serious personal injury, fire, or machine damage. If you notice that any wires or components are damaged while performing a wiring task, replace those wires or components.

MOTOR WIRING. The motor wiring shown in these diagrams is current at the time of printing but may not match your machine. If you find this to be the case, use the wiring diagram inside the motor junction box.















CAPACITORS/INVERTERS. Some capacitors and power inverters store an electrical charge for up to 10 minutes after being disconnected from the power source. To reduce the risk of being shocked, wait at least this long before working on capacitors.

EXPERIENCING DIFFICULTIES. If you are experiencing difficulties understanding the information included in this section, contact our Technical Support at (570) 546-9663.

NOTICE

The photos and diagrams included in this section are best viewed in color. You can view these pages in color at www.grizzly.com.

COLOR KEY

BLACK 	BLUE 	YELLOW 	LIGHT BLUE 
WHITE 	BROWN 	YELLOW GREEN 	BLUE WHITE 
GREEN 	GRAY 	PURPLE 	TURQUOISE 
RED 	ORANGE 	PINK 	



Model G0690/G0691 Wiring Diagram

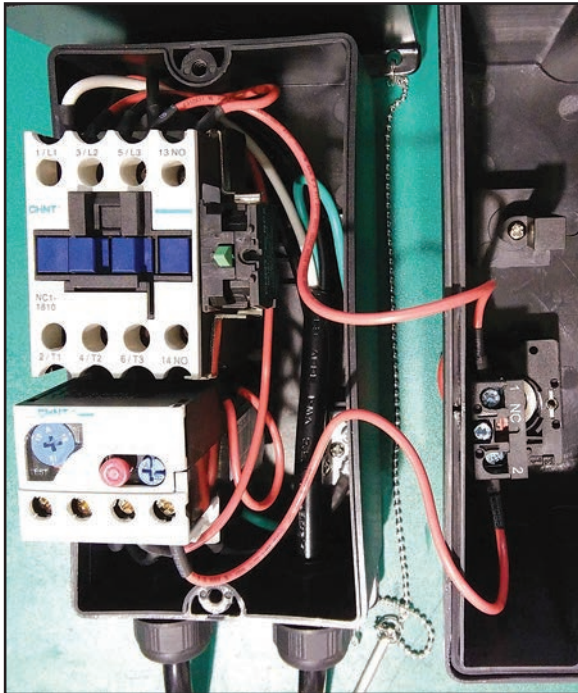

Figure 127. Magnetic switch.

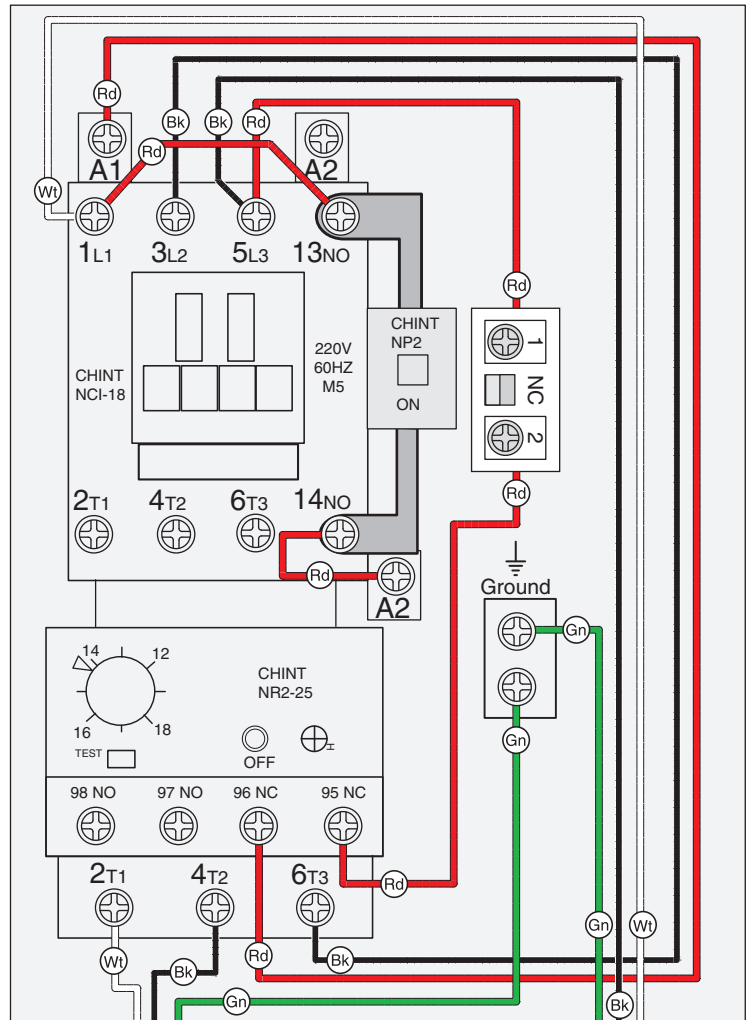

Figure 128. Motor wiring.



Figure 129. Run capacitor.

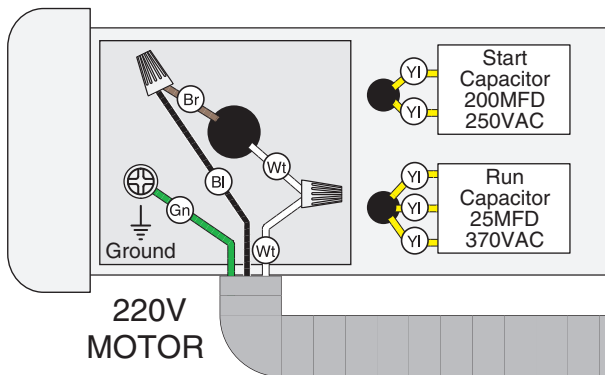
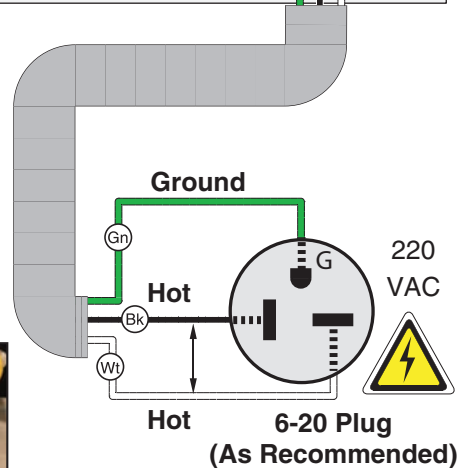
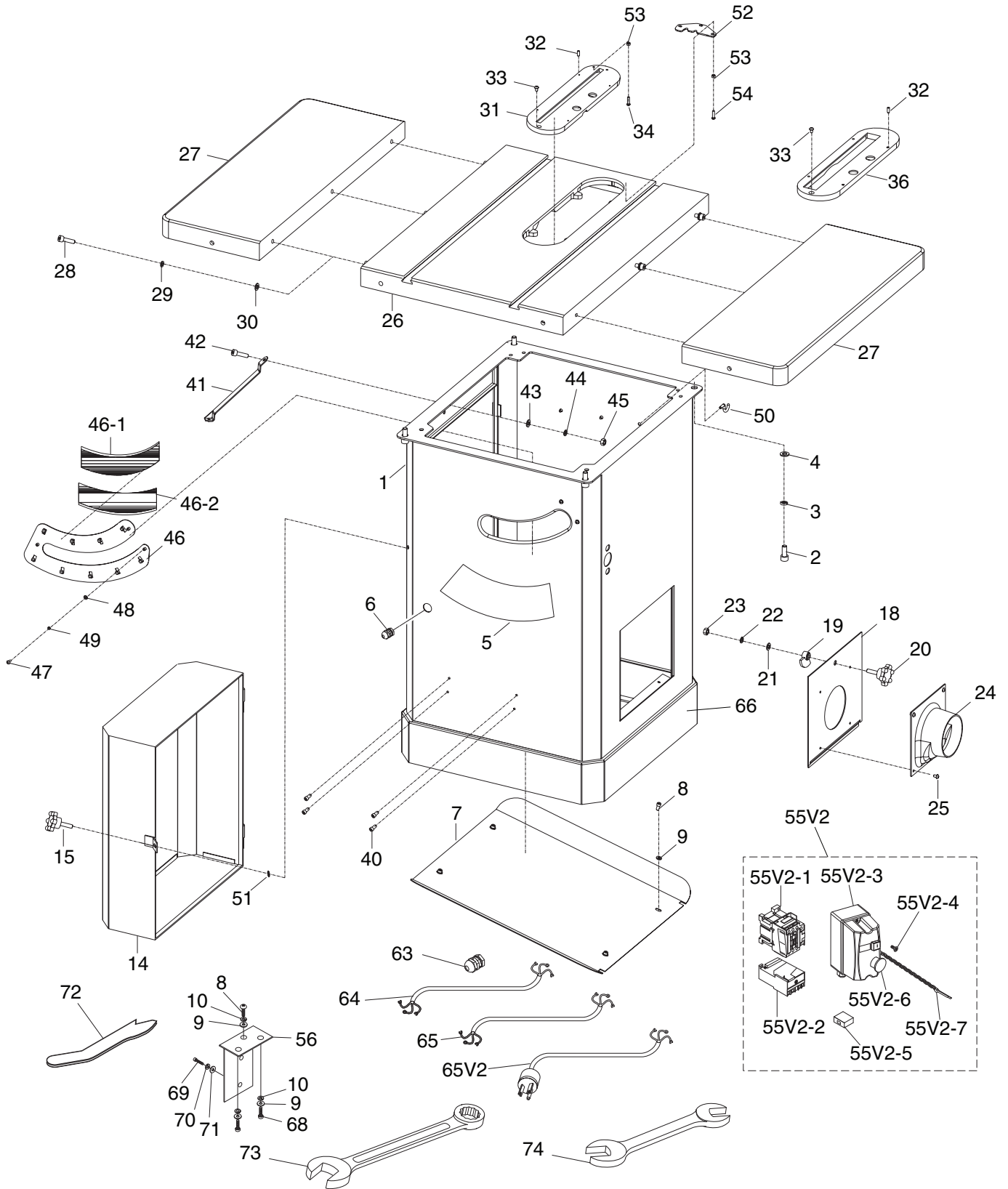

Figure 130. Start capacitor.



SECTION 10: PARTS

Body



Body Parts List

REF	PART #	DESCRIPTION
1	P0690001	CABINET
2	P0690002	CAP SCREW M10-1.25 X 25
3	P0690003	LOCK WASHER 10MM
4	P0690004	FLAT WASHER 10MM
5	P0690005	ANGLE SCALE
6	P0690006	STRAIN RELIEF
7	P0690007	CABINET PLATE
8	P0690008	PHLP HD SCR M6-1 X 12
9	P0690009	FLAT WASHER 6MM
10	P0690010	LOCK WASHER 6MM
14	P0690014	MOTOR COVER
15	P0690015	KNOB M6-1
18	P0690018	CLEANOUT DOOR
19	P0690019	DOOR LATCH
20	P0690020	KNOB M8-1.25
21	P0690021	FLAT WASHER 8MM
22	P0690022	LOCK WASHER 8MM
23	P0690023	HEX NUT M8-1.25
24	P0690024	DUST HOOD
25	P0690025	PHLP HD SCR M5-.8 X 8
26	P0690026	TABLE
27	P0690027	EXTENSION WING
28	P0690028	CAP SCREW M8-1.25 X 30
29	P0690029	LOCK WASHER 8MM
30	P0690030	FLAT WASHER 8MM
31	P0690031	STD TABLE INSERT
32	P0690032	SET SCREW M5-.8 X 12
33	P0690033	PHLP HD SCR M5-.8 X 12
34	P0690034	PHLP HD SCR M5-.8 X 20
36	P0690036	DADO TABLE INSERT
40	P0690040	NAME PLATE RIVET
41	P0690041	SHIPPING BRACE
42	P0690042	HEX BOLT M10-1.5 X 20
43	P0690043	FLAT WASHER 10MM

REF	PART #	DESCRIPTION
44	P0690044	LOCK WASHER 10MM
45	P0690045	HEX NUT M10-1.5
46	P0690046	DUST CLIP
46-1	P0690046-1	UPPER BRUSH
46-2	P0690046-2	LOWER BRUSH
47	P0690047	PHLP HD SCR M4-.7 X 12
48	P0690048	FLAT WASHER 4MM
49	P0690049	LOCK WASHER 4MM
50	P0690050	HOOK
51	P0690051	INT TOOTH WASHER 6MM
52	P0690052	LIMIT PLATE
53	P0690053	HEX NUT M5-.8
54	P0690054	PHLP HD SCR M5-.8 X 20
55V2	P0690055V2	MAG SWITCH ASSY SIEMENS V2.06.17
55V2-1	P0690055V2-1	CONTACTOR SIEMENS 3TS32 10-0X 220V V2.06.17
55V2-2	P0690055V2-2	OL RELAY SIEMENS 3US50 40-2L 12.5-18A V2.06.17
55V2-3	P0690055V2-3	SWITCH BOX FRONT/BACK V2.06.17
55V2-4	P0690055V2-4	MAG SWITCH COVER SCREW V2.06.17
55V2-5	P0690055V2-5	ON/OFF SWITCH CHINT NP2 V2.06.17
55V2-6	P0690055V2-6	E-STOP BUTTON ANIUEC LA158-BE102 V2.06.17
55V2-7	P0690055V2-7	SWITCH DISABLING PIN 3/16 X 3-1/2 V2.06.17
56	P0690056	SWITCH BRACKET
63	P0690063	STRAIN RELIEF
64	P0690064	MOTOR CORD 14AWG X 3C
65V2	P0690065V2	POWER CORD W/PLUG V2.12.09
66	P0690066	GREEN TRIM TAPE
68	P0690068	HEX BOLT M6-1 X 12
69	P0690069	BUTTON HD CAP SCR M5-.8 X 16
70	P0690070	LOCK WASHER 5MM
71	P0690071	FLAT WASHER 5MM
72	P0690072	PUSH STICK
73	P0690073	ARBOR WRENCH 27MM COMBO
74	P0690074	ARBOR WRENCH 22 X 24MM OPEN-ENDS



Trunnion

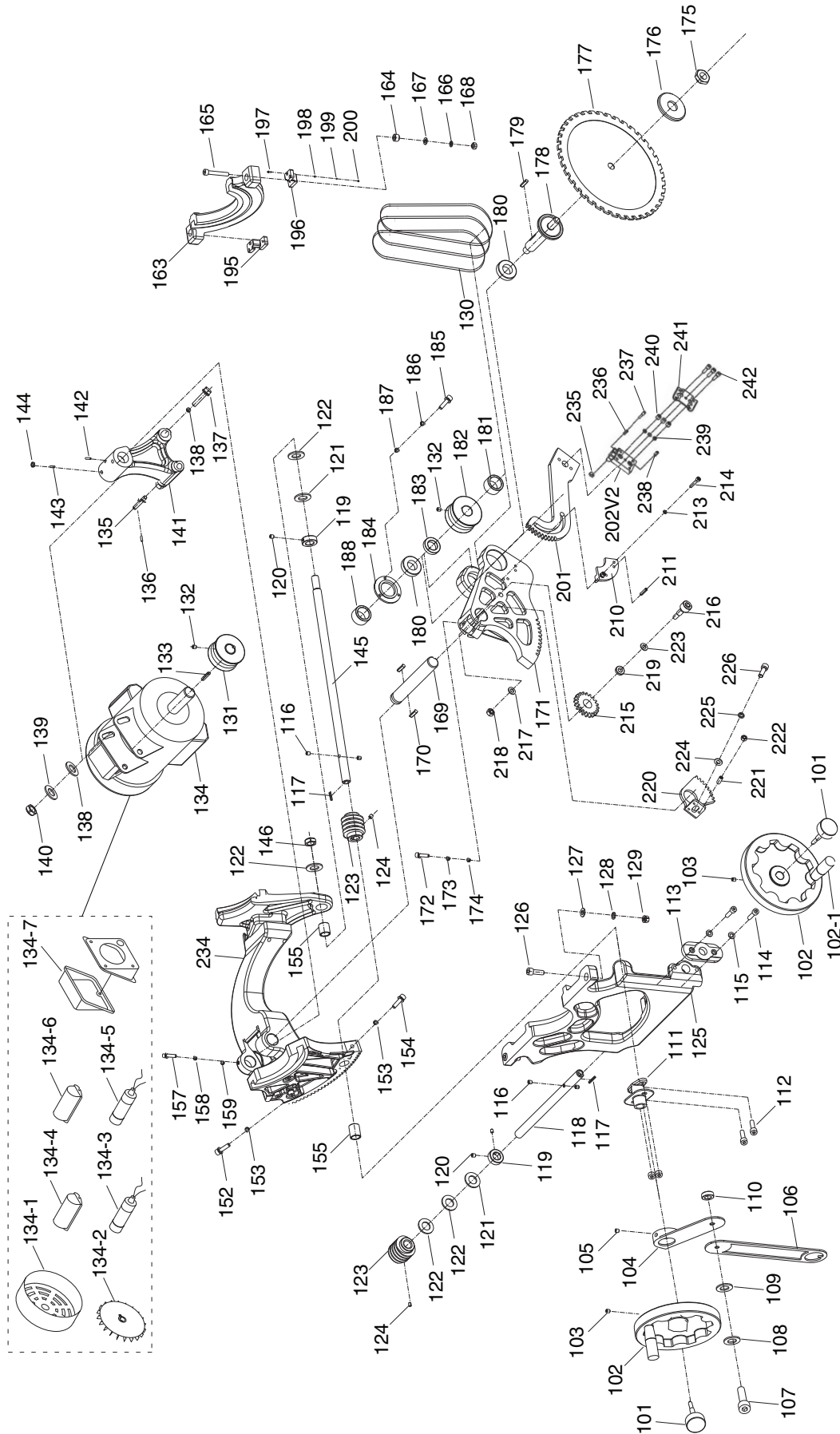

Trunnion Parts List

REF	PART #	DESCRIPTION
101	P0690101	HANDWHEEL LOCK
102	P0690102	HANDWHEEL
102-1	P0690102-1	HANDWHEEL HANDLE
103	P0690103	SET SCREW M5-.8 X 12
104	P0690104	ANGLE POINTER-1
105	P0690105	SET SCREW M5-.8 X 6
106	P0690106	ANGLE POINTER-2
107	P0690107	CAP SCREW M6-1 X 12
108	P0690108	LOCK WASHER 6MM
109	P0690109	FLAT WASHER 6MM
110	P0690110	HEX NUT M6-1
111	P0690111	ANGLE POINTER BRACKET
112	P0690112	CAP SCREW M5-.8 X 25
113	P0690113	PLATE
114	P0690114	CAP SCREW M8-1.25 X 25
115	P0690115	LOCK WASHER 8MM
116	P0690116	PIN-LOCK-SHAFT
117	P0690117	KEY 5 X 5 X 36
118	P0690118	ANGLE SHAFT
119	P0690119	LOCK COLLAR
120	P0690120	SET SCREW M6-1 X 8
121	P0690121	LOCK WASHER 18MM
122	P0690122	COPPER WASHER 18MM
123	P0690123	WORM
124	P0690124	SET SCREW M6-1 X 10
125	P0690125	FRONT TRUNNION
126	P0690126	CAP SCREW M10-1.5 X 30
127	P0690127	FLAT WASHER 10MM
128	P0690128	LOCK WASHER 10MM
129	P0690129	HEX NUT M10-1.5
130	P0690130	BELT SPZ 625
131	P0690131	MOTOR PULLEY
132	P0690132	SET SCREW M5-.8 X 12
133	P0690133	KEY 5 X 5 X 30
134	P0690134	MOTOR 3HP 220V 1-PH
134-1	P0690134-1	FAN COVER
134-2	P0690134-2	MOTOR FAN
134-3	P0690134-3	R CAP 25M 370V 1-3/4 X 3
134-4	P0690134-4	R CAPACITOR COVER
134-5	P0690134-5	S CAP 200M 250V 1-1/4 X 2-3/4
134-6	P0690134-6	S CAPACITOR COVER
134-7	P0690134-7	WIRING JUNCTION BOX
135	P0690135	ORIENTATION PIN
136	P0690136	COTTER PIN 3.5 X 35MM
137	P0690137	HEX BOLT M12-1.75 X 100
138	P0690138	FLAT WASHER 12MM

REF	PART #	DESCRIPTION
139	P0690139	LOCK WASHER 12MM
140	P0690140	HEX NUT M12-1.75
141	P0690141	MOTOR FRAME SUPPORT
142	P0690142	SET SCREW M8-1.25 X 12
143	P0690143	SET SCREW M8-1.25 X 30
144	P0690144	HEX NUT M8-1.25
145	P0690145	HIGH SHAFT
146	P0690146	LOCK NUT M18-1.5
152	P0690152	HEX BOLT M8-1.25 X 20
153	P0690153	HEX NUT M8-1.25
154	P0690154	HEX BOLT M8-1.25 X 35
155	P0690155	FLANGE CASTING SLEEVE
157	P0690157	SET SCREW M8-1.25 X 8
158	P0690158	COMPRESSION SPRING
159	P0690159	BALL
163	P0690163	REAR TRUNNION
164	P0690164	ADJUST BOLT
165	P0690165	CAP SCREW M8-1.25 X 30
166	P0690166	FLAT WASHER 8MM
167	P0690167	LOCK WASHER 8MM
168	P0690168	HEX NUT M8-1.25
169	P0690169	HIGH SHAFT
170	P0690170	KEY 6 X 6 X 50
171	P0690171	GEARED BEARING HOUSING
172	P0690172	HEX BOLT M10-1.5 X 45
173	P0690173	LOCK WASHER 10MM
174	P0690174	FLAT WASHER 10MM
175	P0690175	ARBOR NUT
176	P0690176	ARBOR FLANGE
177	P0690177	BLADE 10" 40T
178	P0690178	BLADE ARBOR
179	P0690179	KEY 5 X 5 X 30
180	P0690180	BALL BEARING 6005ZZ
181	P0690181	COLLAR BLADE ARBOR
182	P0690182	ARBOR PULLEY
183	P0690183	COLLAR BLADE ARBOR
184	P0690184	FLANGE RING
185	P0690185	PHLP HD SCR M5-.8 X 12
186	P0690186	LOCK WASHER 5MM
187	P0690187	FLAT WASHER 5MM
188	P0690188	LOCK NUT M16-1.5
195	P0690195	LEFT BRACKET
196	P0690196	RIGHT BRACKET
197	P0690197	CAP SCREW M8-1.25 X 30
198	P0690198	FLAT WASHER 8MM
199	P0690199	LOCK WASHER 8MM



Trunnion Parts List

REF	PART #	DESCRIPTION
200	P0690200	HEX NUT M8-1.25
201	P0690201	BULL GEAR
202V2	P0690202V2	SPLITTER ADJUST BLOCK V2.10.15
210	P0690210	ORIENTATION BAR
211	P0690211	ROLL PIN 5 X 25
213	P0690213	LOCK WASHER 5MM
214	P0690214	CAP SCREW M5-.8 X 25
215	P0690215	GEAR
216	P0690216	CAP SCREW M10-1.5 X 40
217	P0690217	FLAT WASHER 10MM
218	P0690218	LOCK NUT M10-1.5
219	P0690219	GEAR SLEEVE
220	P0690220	PLATE GEAR
221	P0690221	SET SCREW M6-1 X 20

REF	PART #	DESCRIPTION
222	P0690222	HEX NUT M6-1
223	P0690223	FENDER WASHER 10MM
224	P0690224	FLAT WASHER 8MM
225	P0690225	LOCK WASHER 8MM
226	P0690226	CAP SCREW M8-1.25 X 20
234	P0690234	TRUNNION
235	P0690235	PIN KNOB
236	P0690236	COMPRESSION SPRING
237	P0690237	POSITION PIN SET
238	P0690238	SET SCREW M6-1 X 12
239	P0690239	LOCK WASHER 6MM
240	P0690240	SPACER
241	P0690241	SPLITTER TIGHTENING CLIP
242	P0690242	HEX BOLT M6-1 X 30



Blade Guard

301AV4

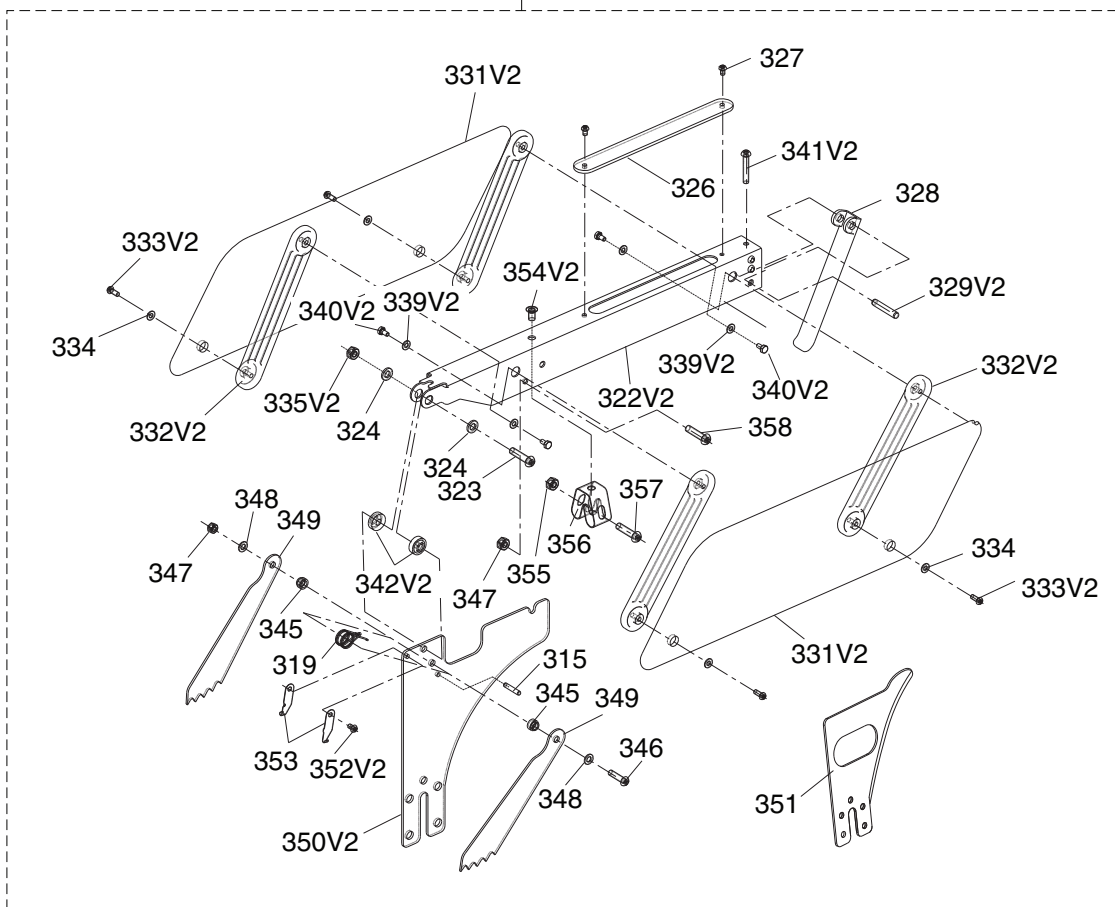

REF	PART #	DESCRIPTION
301AV4	P0690301AV4	BLADE GUARD ASSEMBLY V4.11.10
315	P0690315	ROLL PIN 4 X 20
319	P0690319	TORSION SPRING
322V2	P0690322V2	SUPPORTING ARM V2.10.10
323	P0690323	PHLP HD SCR M6-1 X 25
324	P0690324	FLAT WASHER 6MM
326	P0690326	TOP GUARD
327	P0690327	PHLP HD SCR M4-.7 X 6
328	P0690328	FRONT GUARD
329V2	P0690329V2	ROLL PIN 6 X 32
330	P0690330	SPACER
331V2	P0690331V2	SIDE GUARD V2.10.10
332V2	P0690332V2	GUARD SUPPORT V2.10.10
333V2	P0690333V2	PHLP HD SCR M4-.7 X 10
334	P0690334	FLAT WASHER 5MM
335V2	P0690335V2	LOCK NUT M6-1
339V2	P0690339V2	FLAT WASHER 5MM

REF	PART #	DESCRIPTION
340V2	P0690340V2	HEX BOLT M4-.7 X 8
341V2	P0690341V2	PHLP HD SCR M6-1 X 30
342V2	P0690342V2	SPACER V2.10.10
345	P0690345	SPACER
346	P0690346	HEX BOLT M5-.8 X 20
347	P0690347	LOCK NUT M5-.8
348	P0690348	FLAT WASHER 5MM
349	P0690349	PAWL
350V2	P0690350V2	SPLITTER V2.12.09
351	P0690351	RIVING KNIFE
352V2	P0690352V2	RIVET V2.11.10
353	P0690353	RIVING KNIFE HOOK PLATE
354V2	P0690354V2	RIVET 5 X 12MM V2.11.10
355	P0690355	LOCK NUT M6-1
356	P0690356	GUARD CLAMP
357	P0690357	PHLP HD SCR M6-1 X 35
358	P0690358	HEX BOLT M5-.8 X 8



Miter Gauge

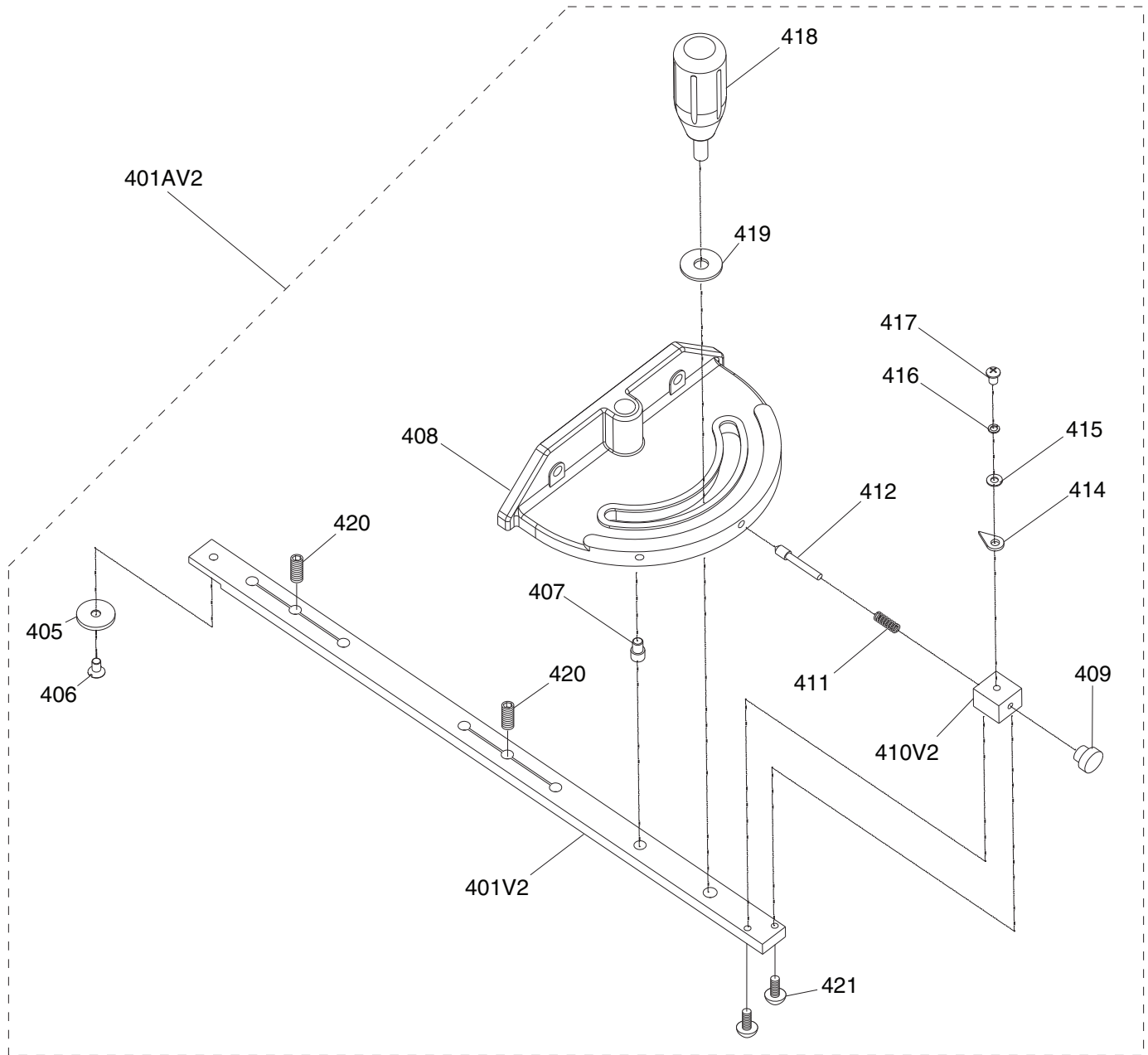

REF	PART #	DESCRIPTION
401AV2	P0690401AV2	MITER GAUGE ASSEMBLY V2.10.15
401V2	P0690401V2	MITER BAR V2.10.15
405	P0690405	MITER RING
406	P0690406	FLAT HD SCR M5-.8 X 8
407	P0690407	MITER BODY PIVOT PIN
408	P0690408	MITER GAUGE BODY
409	P0690409	MITER STOP PIN KNOB
410V2	P0690410V2	MITER STOP PIN BLOCK V2.10.15
411	P0690411	COMPRESSION SPRING

REF	PART #	DESCRIPTION
412	P0690412	MITER STOP PIN
414	P0690414	POINTER MITER GAUGE
415	P0690415	FLAT WASHER 4MM
416	P0690416	LOCK WASHER 4MM
417	P0690417	PHLP HD SCR M4-.7 X 8
418	P0690418	MITER KNOB
419	P0690419	FENDER WASHER 8MM
420	P0690420	SET SCREW M8-1.25 X 6
421	P0690421	BUTTON HD CAP SCR M4-.7 X 10



Fence

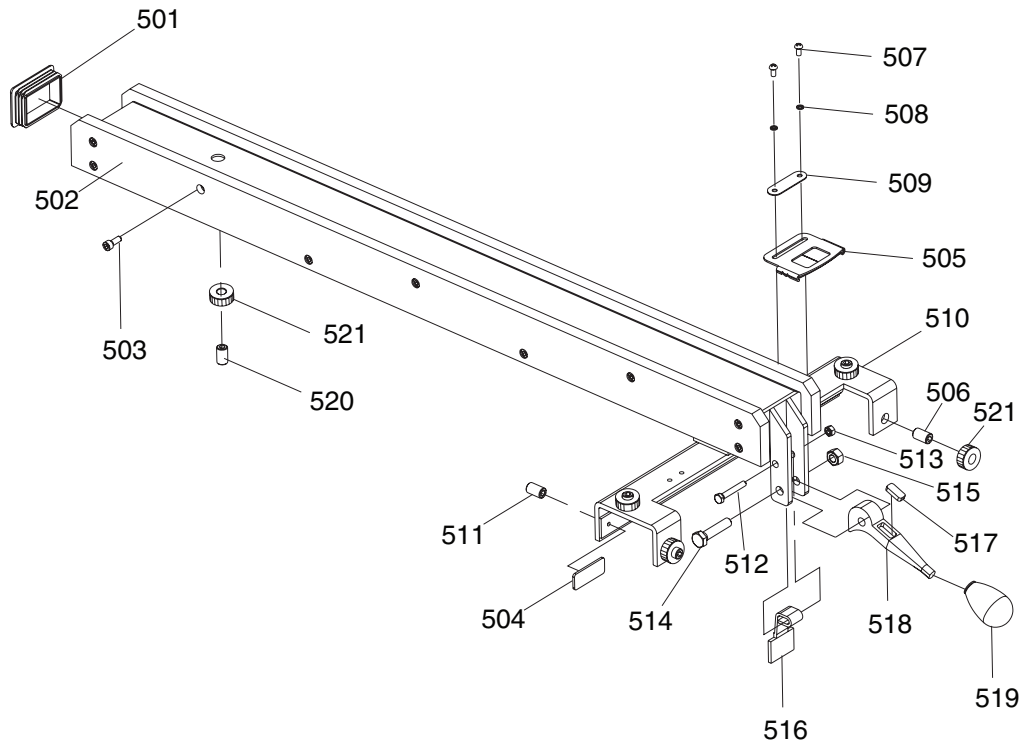

REF	PART #	DESCRIPTION
501	P0690501	FENCE INSERT
502	P0690502	FENCE FACE
503	P0690503	CAP SCREW M6-1 X 16
504	P0690504	GLIDE PAD
505	P0690505	FENCE SCALE WINDOW
506	P0690506	SET SCREW M12-1.75 X 15
507	P0690507	PHLP HD SCR M5-.8 X 10
508	P0690508	LOCK WASHER 5MM
509	P0690509	INDICATOR
510	P0690510	FENCE BODY
511	P0690511	SET SCREW

REF	PART #	DESCRIPTION
512	P0690512	HEX BOLT M6-1 X 40
513	P0690513	LOCK NUT M6-1
514	P0690514	HEX BOLT M10-1.5 X 45
515	P0690515	LOCK NUT M10-1.25
516	P0690516	CAM FOOT
517	P0690517	MAGNET
518	P0690518	CAM
519	P0690519	FENCE LOCK KNOB
520	P0690520	BRASS GLIDE SCREW M12-1.75 X 30
521	P0690521	SPECIAL LOCKING NUT M12-1.75



Extension Table (G0690)

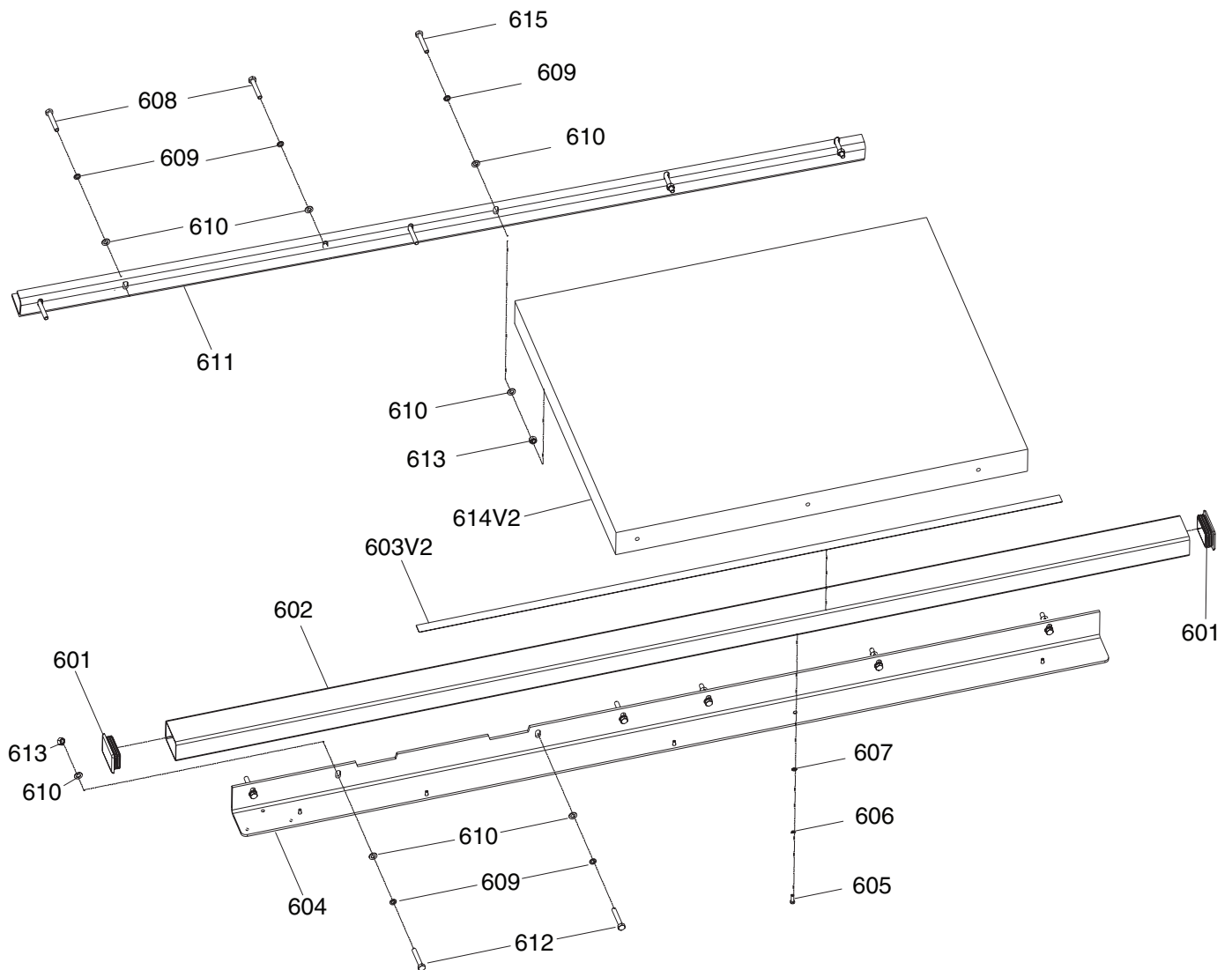

REF	PART #	DESCRIPTION
601	P0690601	FENCE INSERT
602	P0690602	GUIDE TUBE
603V2	P0690603V2	SCALE V2.04.11
604	P0690604	FRONT RAIL
605	P0690605	CAP SCREW M6-1 X 16
606	P0690606	LOCK WASHER 6MM
607	P0690607	FLAT WASHER 6MM
608	P0690608	HEX BOLT 5/16-18 X 1-1/2

REF	PART #	DESCRIPTION
609	P0690609	LOCK WASHER 8MM
610	P0690610	FLAT WASHER 8MM
611	P0690611	REAR RAIL
612	P0690612	HEX BOLT M8-1.25 X 40
613	P0690613	HEX NUT M8-1.25
614V2	P0690614V2	TABLE BOARD V2.11.13
615	P0690615	HEX BOLT M8-1.25 X 30



Extension Table (G0691)

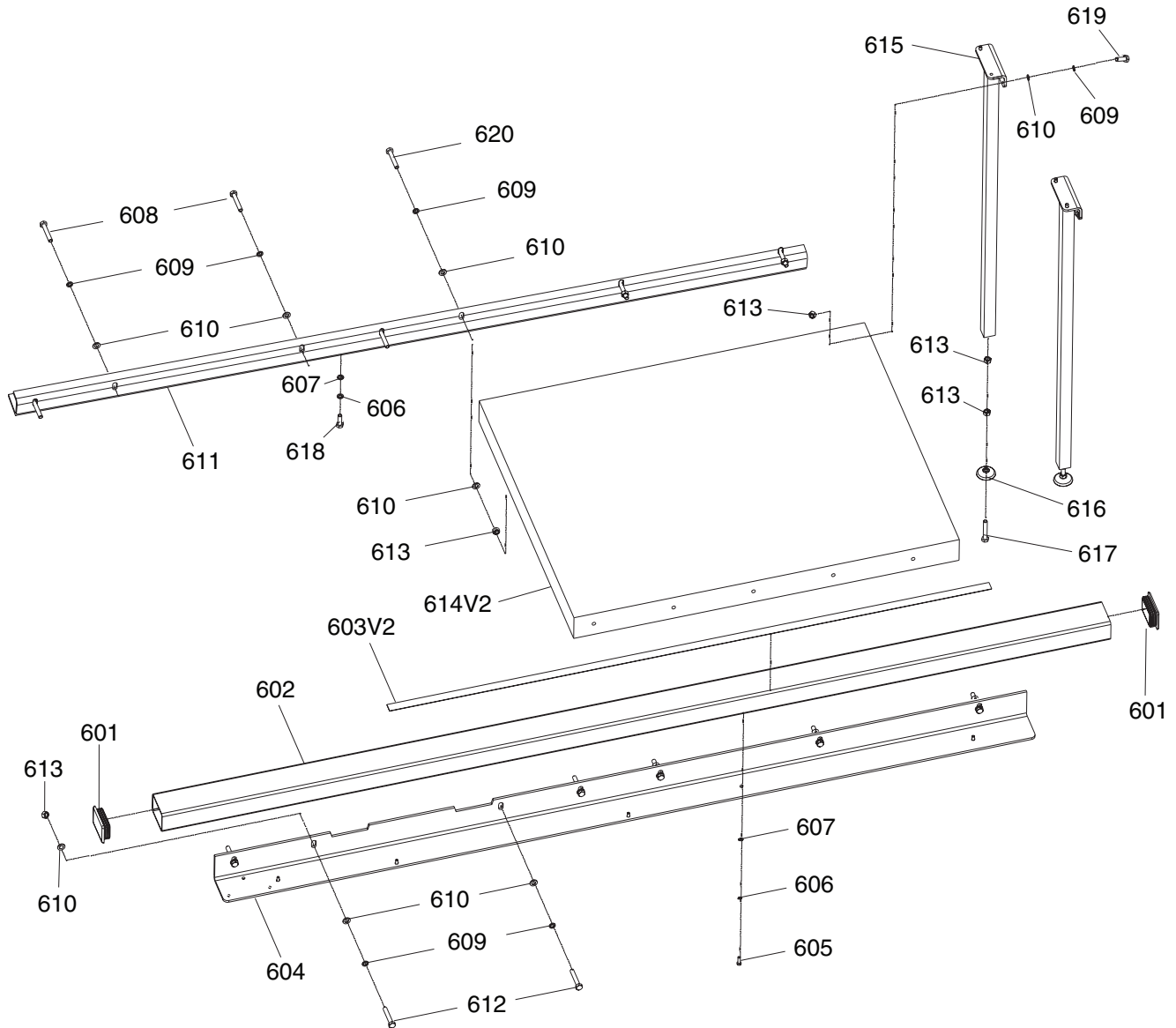

REF	PART #	DESCRIPTION
601	P0691601	FENCE INSERT
602	P0691602	GUIDE TUBE
603V2	P0691603V2	SCALE V2.04.11
604	P0691604	FRONT RAIL
605	P0691605	CAP SCREW M6-1 X 16
606	P0691606	LOCK WASHER 6MM
607	P0691607	FLAT WASHER 6MM
608	P0691608	HEX BOLT 5/16-18 X 1-1/2
609	P0691609	LOCK WASHER 8MM
610	P0691610	FLAT WASHER 8MM

REF	PART #	DESCRIPTION
611	P0691611	REAR RAIL
612	P0691612	HEX BOLT M8-1.25 X 40
613	P0691613	HEX NUT M8-1.25
614V2	P0691614V2	TABLE BOARD V2.11.13
615	P0691615	LEG
616	P0691616	FOOT
617	P0691617	HEX BOLT M8-1.25 X 60
618	P0691618	CAP SCREW M6-1 X 16
619	P0691619	CAP SCREW M8-1.25 X 20
620	P0691620	HEX BOLT M8-1.25 X 30



Labels and Cosmetics

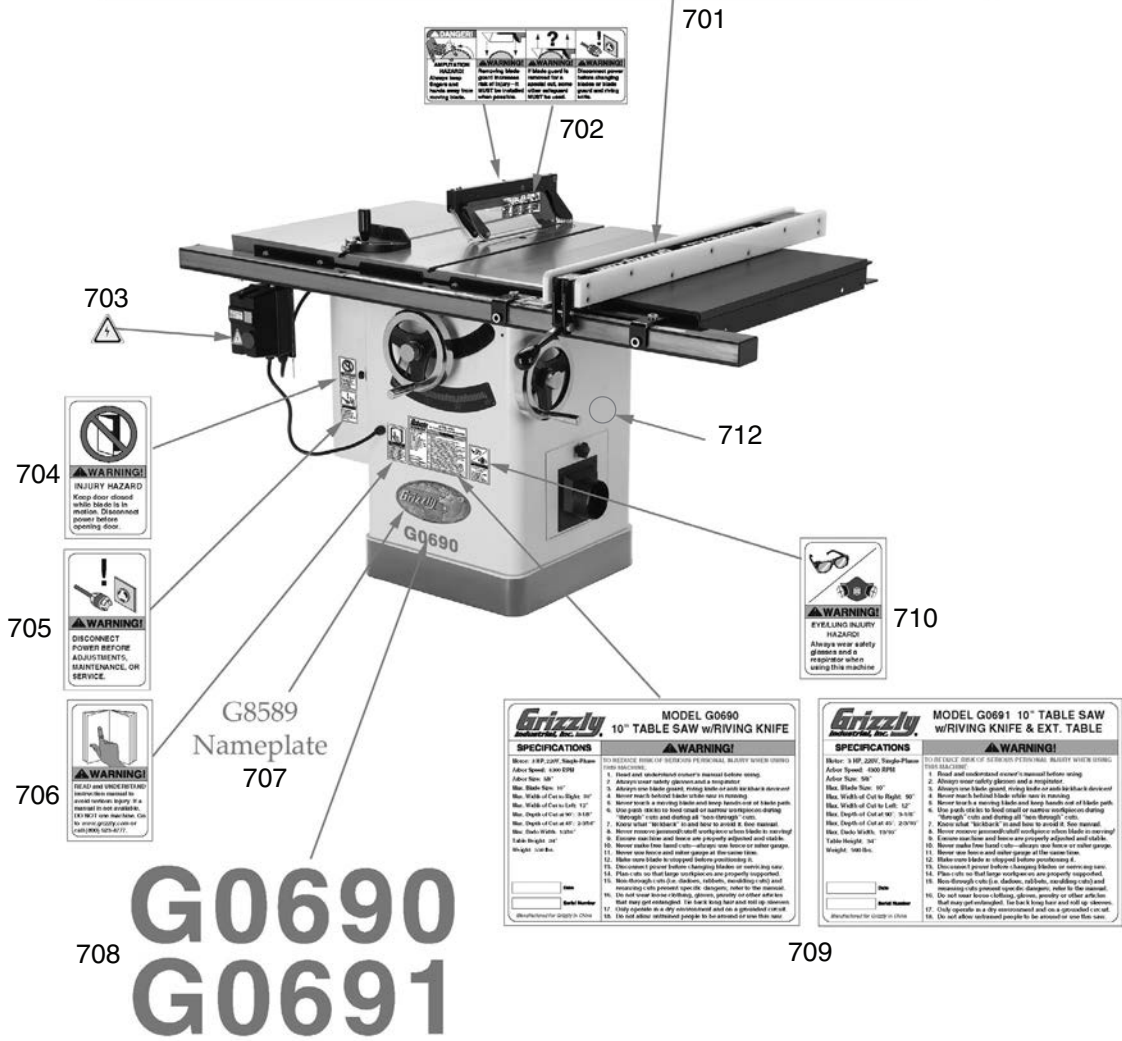

G0690
G0691

REF	PART #	DESCRIPTION
701	P0690701	FENCE LABEL
702	P0690702	GUARD LABEL
703	P0690703	ELECTRICITY LABEL
704	P0690704	KEEP CLOSED LABEL
705	P0690705	UNPLUG POWER LABEL
706	P0690706	READ MANUAL LABEL
707	P0690707	GRIZZLY NAMEPLATE

REF	PART #	DESCRIPTION
708	P0690708	MODEL # LABEL G0690
708	P0691708	MODEL # LABEL G0691
709	P0690709	MACHINE ID LABEL G0690
709	P0691709	MACHINE ID LABEL G0691
710	P0690710	GLASSES RESPIRATOR LABEL
712	P0690712	"PUTTY" PAINT

⚠ WARNING

Safety labels warn about machine hazards and ways to prevent injury. The owner of this machine **MUST** maintain the original location and readability of the labels on the machine. If any label is removed or becomes unreadable, **REPLACE** that label before using the machine again. Contact Grizzly at (800) 523-4777 or www.grizzly.com to order new labels.





WARRANTY CARD

Name _____
 Street _____
 City _____ State _____ Zip _____
 Phone # _____ Email _____
 Model # _____ Order # _____ Serial # _____

The following information is given on a voluntary basis. It will be used for marketing purposes to help us develop better products and services. **Of course, all information is strictly confidential.**

1. How did you learn about us?

<input type="checkbox"/> Advertisement	<input type="checkbox"/> Friend	<input type="checkbox"/> Catalog
<input type="checkbox"/> Card Deck	<input type="checkbox"/> Website	<input type="checkbox"/> Other:

2. Which of the following magazines do you subscribe to?

<input type="checkbox"/> Cabinetmaker & FDM	<input type="checkbox"/> Popular Science	<input type="checkbox"/> Wooden Boat
<input type="checkbox"/> Family Handyman	<input type="checkbox"/> Popular Woodworking	<input type="checkbox"/> Woodshop News
<input type="checkbox"/> Hand Loader	<input type="checkbox"/> Precision Shooter	<input type="checkbox"/> Woodsmith
<input type="checkbox"/> Handy	<input type="checkbox"/> Projects in Metal	<input type="checkbox"/> Woodwork
<input type="checkbox"/> Home Shop Machinist	<input type="checkbox"/> RC Modeler	<input type="checkbox"/> Woodworker West
<input type="checkbox"/> Journal of Light Cont.	<input type="checkbox"/> Rifle	<input type="checkbox"/> Woodworker's Journal
<input type="checkbox"/> Live Steam	<input type="checkbox"/> Shop Notes	<input type="checkbox"/> Other:
<input type="checkbox"/> Model Airplane News	<input type="checkbox"/> Shotgun News	
<input type="checkbox"/> Old House Journal	<input type="checkbox"/> Today's Homeowner	
<input type="checkbox"/> Popular Mechanics	<input type="checkbox"/> Wood	

3. What is your annual household income?

<input type="checkbox"/> \$20,000-\$29,000	<input type="checkbox"/> \$30,000-\$39,000	<input type="checkbox"/> \$40,000-\$49,000
<input type="checkbox"/> \$50,000-\$59,000	<input type="checkbox"/> \$60,000-\$69,000	<input type="checkbox"/> \$70,000+

4. What is your age group?

<input type="checkbox"/> 20-29	<input type="checkbox"/> 30-39	<input type="checkbox"/> 40-49
<input type="checkbox"/> 50-59	<input type="checkbox"/> 60-69	<input type="checkbox"/> 70+

5. How long have you been a woodworker/metalworker?

<input type="checkbox"/> 0-2 Years	<input type="checkbox"/> 2-8 Years	<input type="checkbox"/> 8-20 Years	<input type="checkbox"/> 20+ Years
------------------------------------	------------------------------------	-------------------------------------	------------------------------------

6. How many of your machines or tools are Grizzly?

<input type="checkbox"/> 0-2	<input type="checkbox"/> 3-5	<input type="checkbox"/> 6-9	<input type="checkbox"/> 10+
------------------------------	------------------------------	------------------------------	------------------------------

7. Do you think your machine represents a good value? Yes No

8. Would you recommend Grizzly Industrial to a friend? Yes No

9. Would you allow us to use your name as a reference for Grizzly customers in your area?
Note: We never use names more than 3 times. Yes No

10. Comments: _____

CUT ALONG DOTTED LINE

FOLD ALONG DOTTED LINE



Place
Stamp
Here



GRIZZLY INDUSTRIAL, INC.
P.O. BOX 2069
BELLINGHAM, WA 98227-2069



FOLD ALONG DOTTED LINE

Send a Grizzly Catalog to a friend:

Name _____
Street _____
City _____ State _____ Zip _____

TAPE ALONG EDGES--PLEASE DO NOT STAPLE

WARRANTY AND RETURNS

Grizzly Industrial, Inc. warrants every product it sells for a period of **1 year** to the original purchaser from the date of purchase. This warranty does not apply to defects due directly or indirectly to misuse, abuse, negligence, accidents, repairs or alterations or lack of maintenance. This is Grizzly's sole written warranty and any and all warranties that may be implied by law, including any merchantability or fitness, for any particular purpose, are hereby limited to the duration of this written warranty. We do not warrant or represent that the merchandise complies with the provisions of any law or acts unless the manufacturer so warrants. In no event shall Grizzly's liability under this warranty exceed the purchase price paid for the product and any legal actions brought against Grizzly shall be tried in the State of Washington, County of Whatcom.

We shall in no event be liable for death, injuries to persons or property or for incidental, contingent, special, or consequential damages arising from the use of our products.

To take advantage of this warranty, contact us by mail or phone and give us all the details. We will then issue you a "Return Number," which must be clearly posted on the outside as well as the inside of the carton. We will not accept any item back without this number. Proof of purchase must accompany the merchandise.

The manufacturers reserve the right to change specifications at any time because they constantly strive to achieve better quality equipment. We make every effort to ensure that our products meet high quality and durability standards and we hope you never need to use this warranty.

Please feel free to write or call us if you have any questions about the machine or the manual.

Thank you again for your business and continued support. We hope to serve you again soon.

grizzly.com[®]
TOOL WEBSITE

Buy Direct and Save with Grizzly[®] – Trusted, Proven and a Great Value!
~Since 1983~

*Visit Our Website Today For
Current Specials!*

**ORDER
24 HOURS A DAY!
1-800-523-4777**

