



JOHN DEERE

OPERATOR'S MANUAL

130 LB. Push Spreader

LP67699
45383
3/07/17
(English)

Introduction

Using Your Operator's Manual

Read this entire operator's manual, especially the safety information, before operating.

This manual is an important part of your machine. Keep all manuals in a convenient location so they can be accessed easily.

Use the safety and operating information in the operator's manual to operate and service the product safely and correctly.

If you have any questions or concerns with the assembly, installation, or operation of this attachment, see your local John Deere dealer.

Table of Contents

Introduction	2
Safety	2
Assembly	3
Operation	10
Service	11
Repair Parts	12

Original instructions. All information, illustrations and specifications in this manual are based on the latest information available at the time of publication.

The right is reserved to make changes at any time without notice.

Safety

Operating Safely

- Read the operator's manual carefully. Be thoroughly familiar with the controls and the proper use of the equipment. Know how to stop the machine and disengage the controls quickly.
- Read the instruction label on the lawn chemicals before handling and applying them.
- This attachment is intended for use in lawn care and home applications. Do not use for uses other than intended by the manufacturer.
- Do not modify machine or safety devices. Unauthorized modifications to the machine or attachment may impair its function and safety.
- Do not let children or an untrained person operate machine.
- Do not let anyone sit or ride on equipment during operation.
- Make any necessary adjustments before you operate.

Practice Safe Maintenance

- Only qualified, trained adults should service this machine.
- Understand service procedure before doing work. Keep area clean and dry.
- Never lubricate, service or adjust the machine or attachment while it is moving. Keep safety devices in place and in working condition. Keep hardware tight.
- Keep hands, feet, clothing, jewelry, and long hair away from any moving parts, to prevent them from getting caught.
- Keep all parts in good condition and properly installed. Fix damage immediately. Replace worn or broken parts. Replace all worn or damaged safety and instruction decals.
- Check all hardware at frequent intervals to be sure the equipment is in safe working condition.
- Do not modify machine or safety devices. Unauthorized modifications to the machine or attachment may impair its function and safety.

Wear Appropriate Clothing

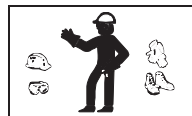

- Always wear eye protection when operating the machine.
- Wear close fitting clothing and safety equipment appropriate for the job.
- While operating this machine, always wear substantial footwear and long trousers. Do not operate the equipment when barefoot or wearing open sandals.

Assembly

Parts in Carton

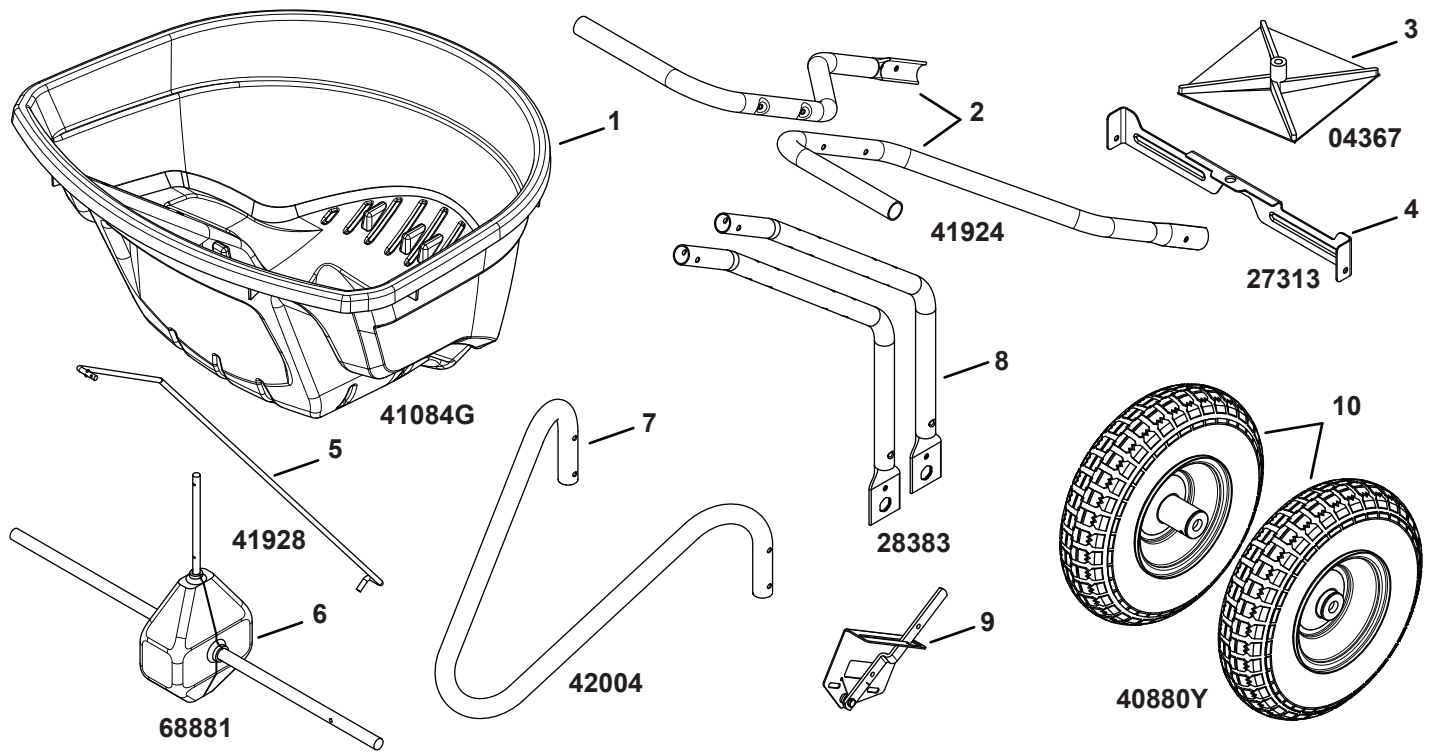

Description

Hopper (1)

Qty

1

T-Handles (2)

2

Spreader Impeller (3)

1

Cross Brace (4)

1

Flow Control Rod (5)

1

Description

Axle/Gearbox Assembly (6)

Qty

1

Stand Tube (7)

1

Hopper Support Tubes (8)

2

Flow Control Assembly (9)

1

Wheels (10)

2

Assembly

Parts Bag Contents

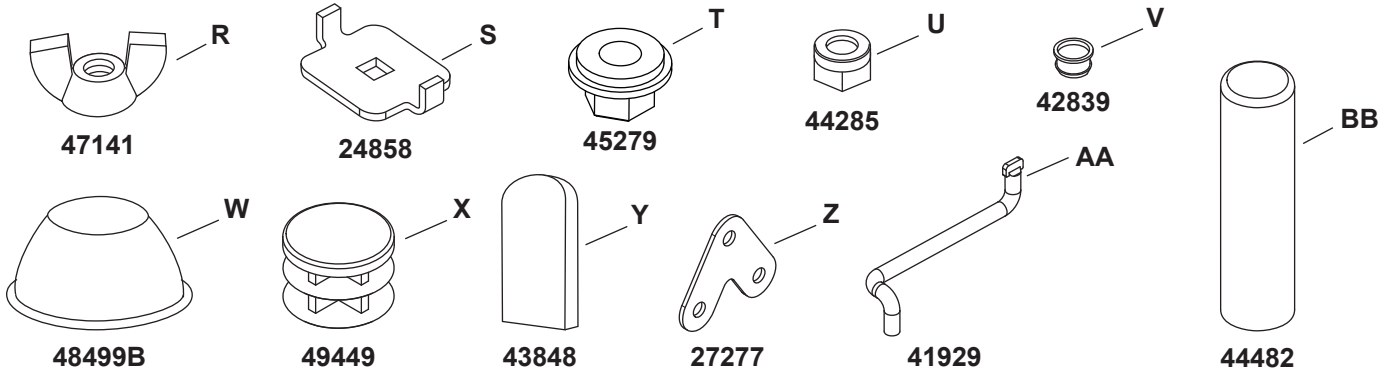
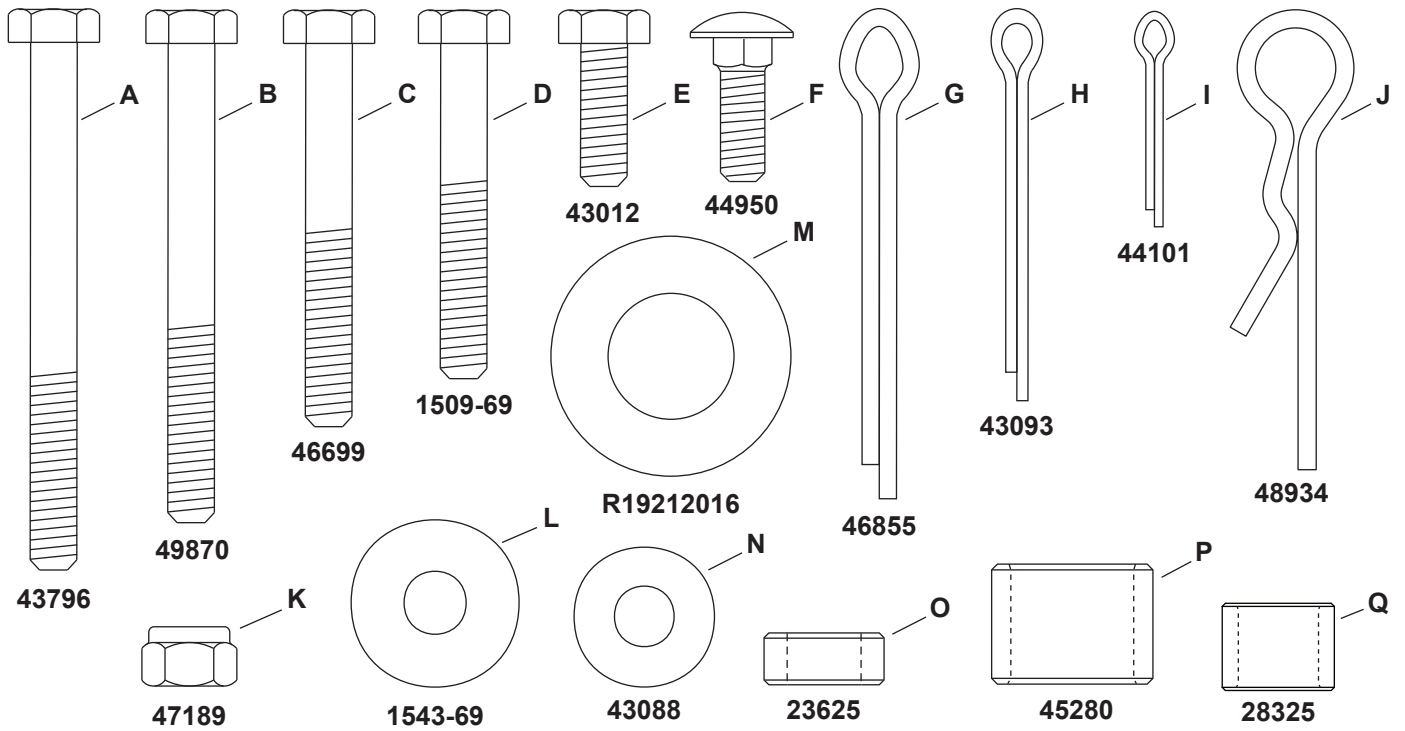

Description	Qty
Hex Bolt, 1/4" x 2-3/4" (A)	2
Hex Bolt, 1/4" x 2-1/2" (B)	2
Hex Bolt, 1/4" x 2" (C)	2
Hex Bolt, 1/4" x 1-3/4" (D)	6
Hex Bolt, 1/4" x 3/4" (E)	1
Carriage Bolt, 1/4" x 3/4" (F)	1
Hairpin Cotter, 3/16" x 2" (G)	1
Hairpin Cotter, 1/8" x 1-1/2" (H)	1
Hairpin Cotter, 3/32" x 3/4" (I)	1
Hairpin, Agitator (J)	1
Hex Nut, 1/4" Nylock (K)	13
Washer, Nylon (L)	5
Washer, 5/8" (M)	4
Washer, 1/4" (N)	9

Description	Qty
Spacer, 1/4" long (O)	1
Spacer (P)	2
Spacer (Q)	2
Wing Nut (R)	1
Adjustable Stop (S)	1
Hex Bushing (T)	2
Hopper Bushing (U)	1
Bushing (V)	1
Hub Cap (W)	2
Plug (X)	2
Control Arm Grip (Y)	1
Drive Link Bracket (Z)	1
Drive Link Rod (AA)	1
Handle Grip (BB)	2

Assembly

TOOLS REQUIRED FOR ASSEMBLY

- (1) Hammer
- (1) Pliers
- (2) 7/16" Wrenches

Assembly Step 1

Insert the plugs (X) into the end of the hopper support tubes (8).

Press the hex bushings (T) into the hex holes in the bottom of the hopper support tubes (8).

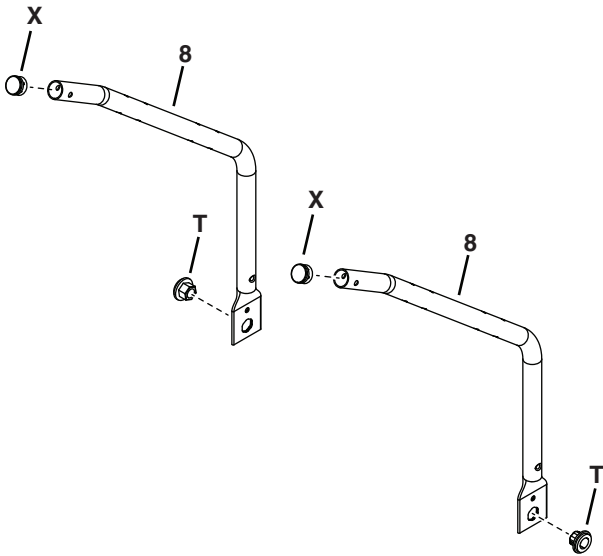

Assembly Step 2

Turn the gearbox assembly (6) as shown so that the hole in the axle is on the right side.

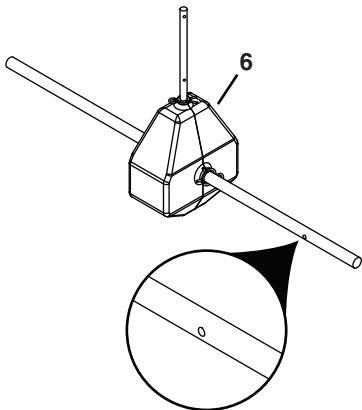

Assembly Step 3

Slide the hopper support tubes (8) onto the gearbox axle.

Install the stand tube (7) between the hopper support tubes (8) as shown, using two 1/4" x 2" hex bolts (C), spacers (Q), and 1/4" nylock nuts (K). Place the spacers between the hopper support tubes and the stand tube.

Do not tighten completely.

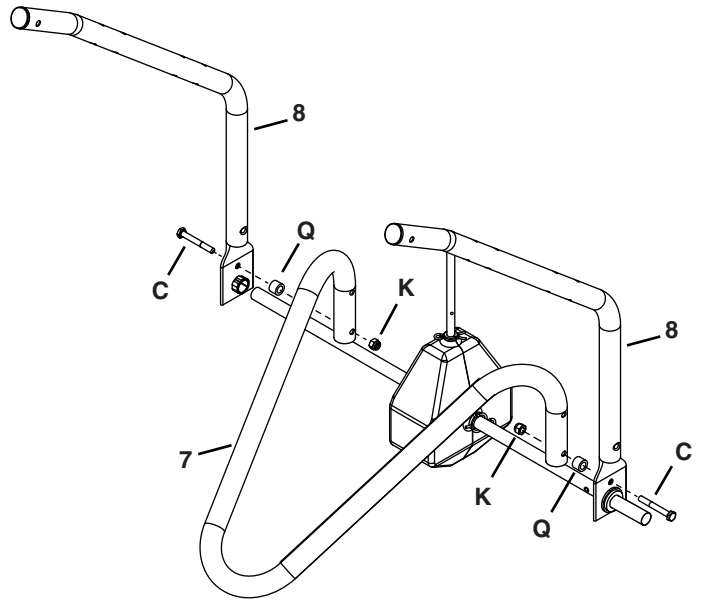

Assembly Step 4

Insert the bushing (V) into the cross brace (4).

Slide the cross brace (4) onto the vertical gearbox shaft and attach the cross brace (4) to the hopper support tubes (8) using two 1/4" x 2-1/2" hex bolts (B) and 1/4" nylock nuts (K). **Do not tighten completely.**

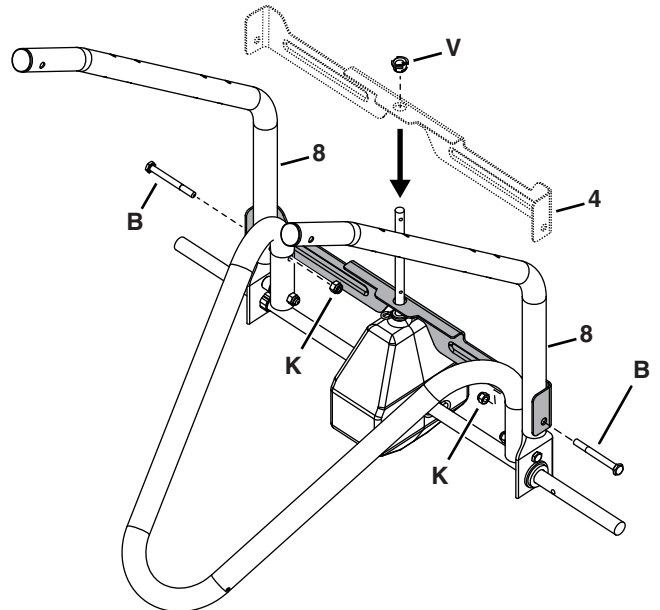

Assembly

Assembly Step 5

Slide the spreader impeller (3) onto the spreader shaft and secure it with a $1/8"$ x $1-1/2"$ cotter pin (H).

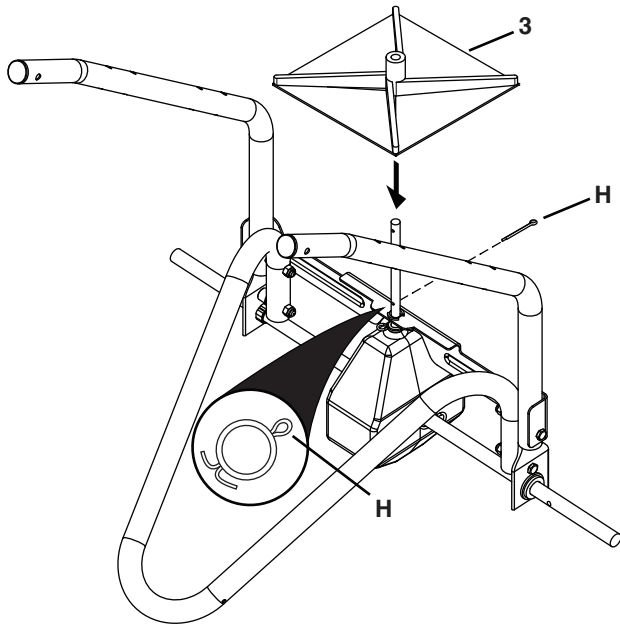

Assembly Step 7

Install the drive link bracket (Z) onto the end of the drive link rod (AA).

Attach the drive link bracket (Z) to the bracket already attached to the bottom of the hopper using a $1/4"$ x $3/4"$ hex bolt (E) and a $1/4"$ nylock nut (K). Tighten the nut and then back it off $1/4$ to $1/2$ turn.

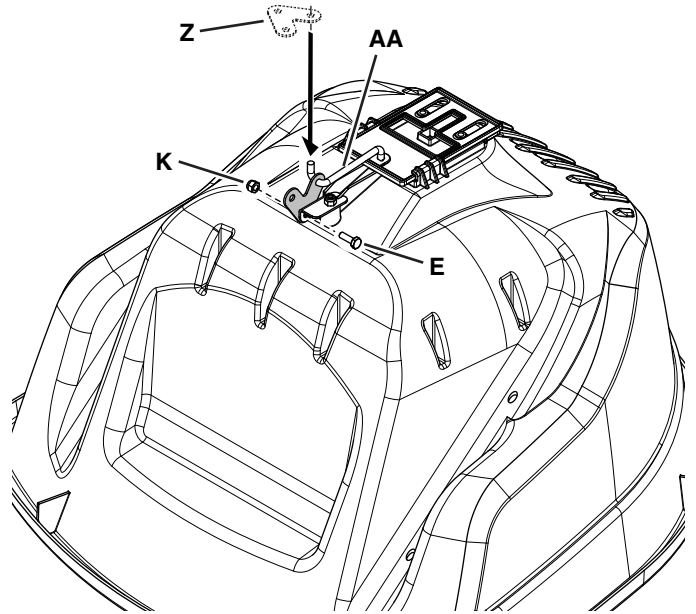

Assembly Step 6

Install the flattened end of the drive link rod (AA) into the hole in the flow plate. Twist the rod to lock it in the flow plate.

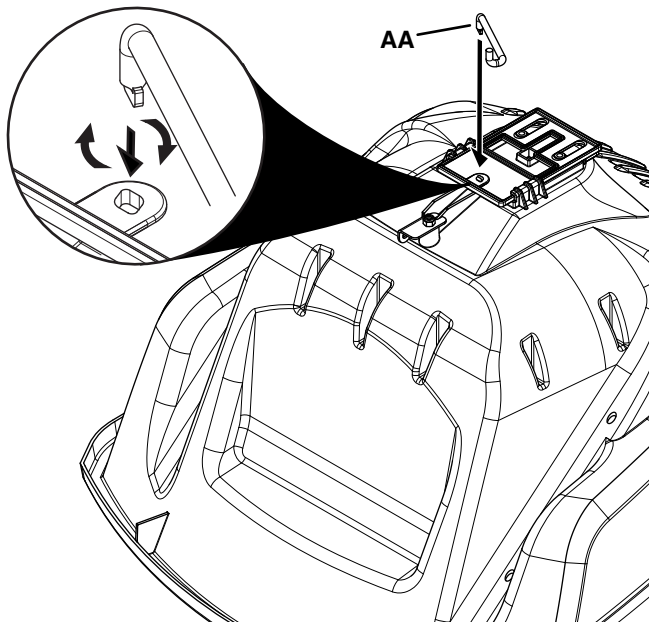

Assembly Step 8

Place the hopper on the hopper support tubes, inserting the spreader shaft up through the square hole in the bottom of the hopper.

Slide the hopper bushing (U) onto the spreader shaft and insert it into the bottom of the hopper.

Slide the spacer (O) onto the spreader shaft.

Install the agitator hairpin (J) in the spreader shaft.

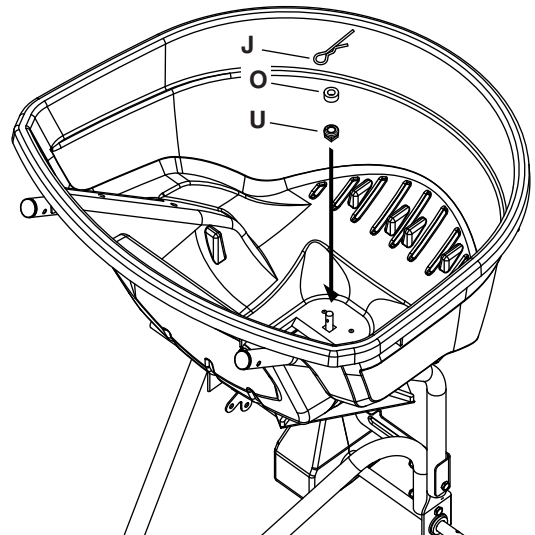

Assembly

Assembly Step 9

Attach the hopper to the hopper support tubes using four 1/4" x 1-3/4" hex bolts (D), 1/4" washers (N), nylon washers (L) and 1/4" nylock nuts (K). **Tighten.**

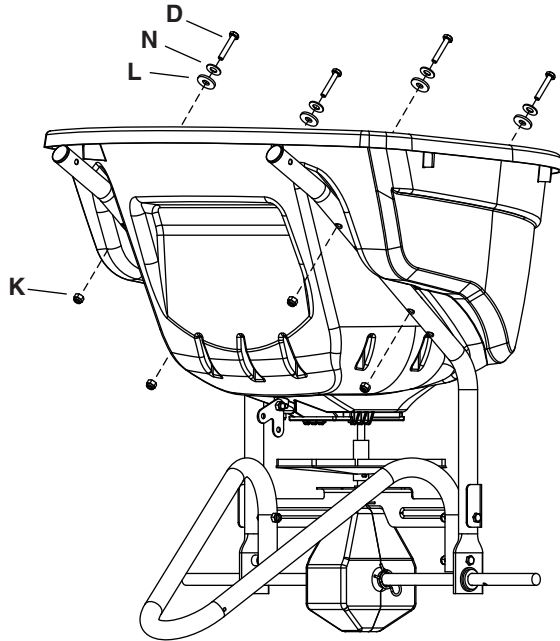

Assembly Step 11

Slide a 5/8" washer (M), a spacer (P), a 5/8" washer (M) and a wheel (10) onto the end of the axle with a hole.

Secure the wheel to the axle with a 3/16" x 2" cotter pin (G), spreading the ends of the cotter pin.

Using a hammer, carefully tap a hub cap (W) onto the axle.

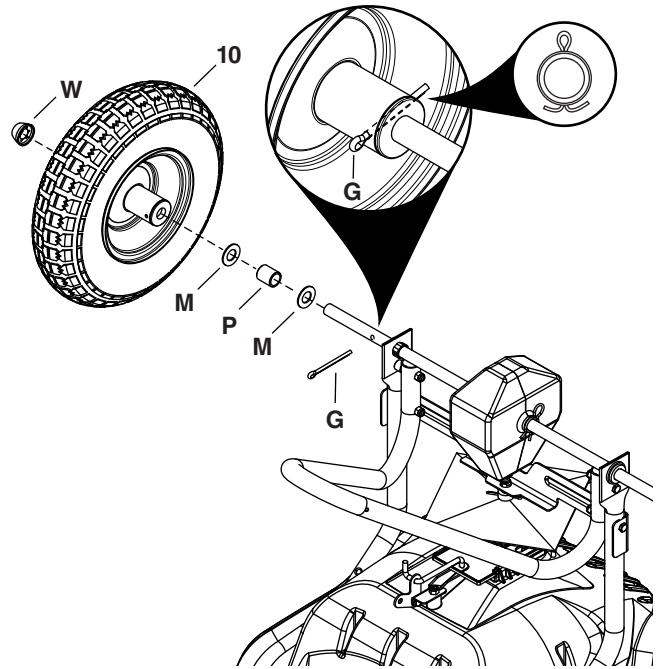

Assembly Step 10

Tighten the bolts and nuts assembled in steps 3 and 4.

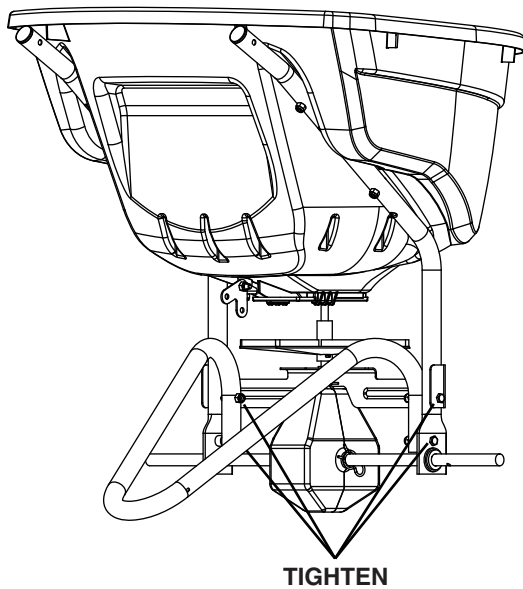

Assembly Step 12

Slide a 5/8" washer (M), a spacer (P), a 5/8" washer (M) and a wheel (10) onto the end of the axle without a hole.

Using a hammer, carefully tap a hub cap (W) onto the axle.

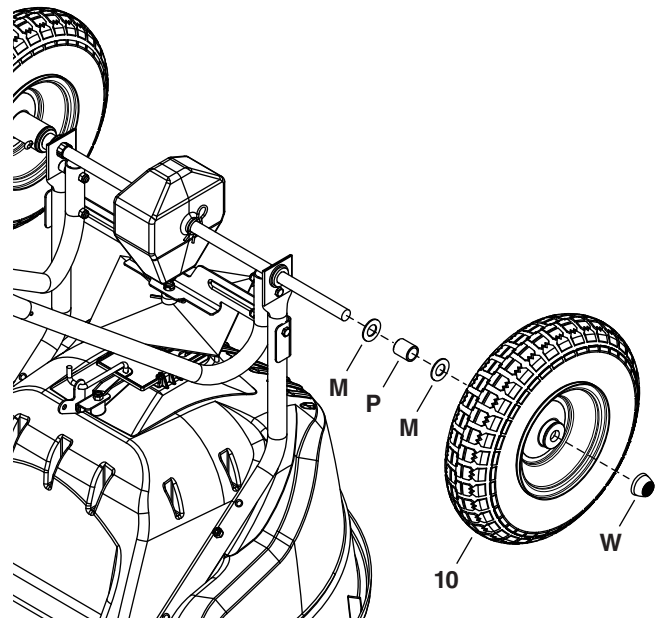

Assembly

Assembly Step 13

Attach the handle tubes (2) to the hopper support tubes using two 1/4" x 1-3/4" hex bolts (D), and 1/4" nylock nuts (K). **Tighten.**

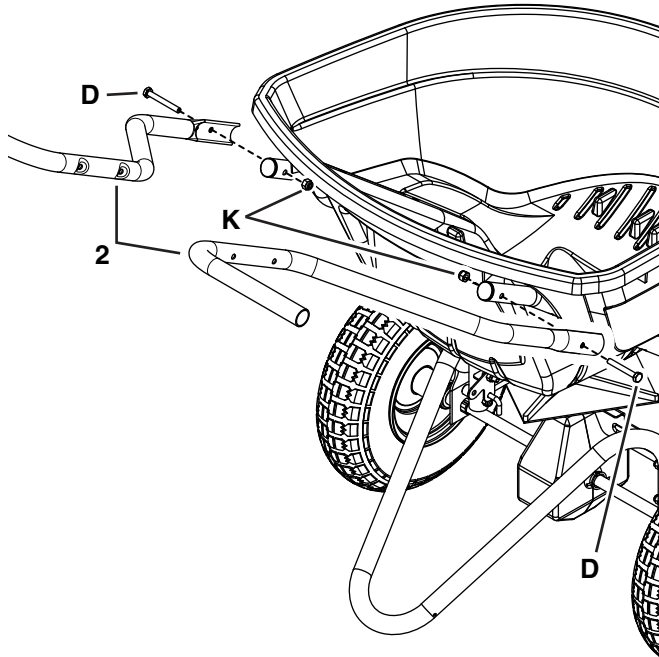

Assembly Step 14

Attach the flow control bracket (9) to the handle tubes using two 1/4" x 2-3/4" hex bolts (A), four 1/4" washers (N) and two 1/4" nylock nuts (K). **Do not tighten yet.**

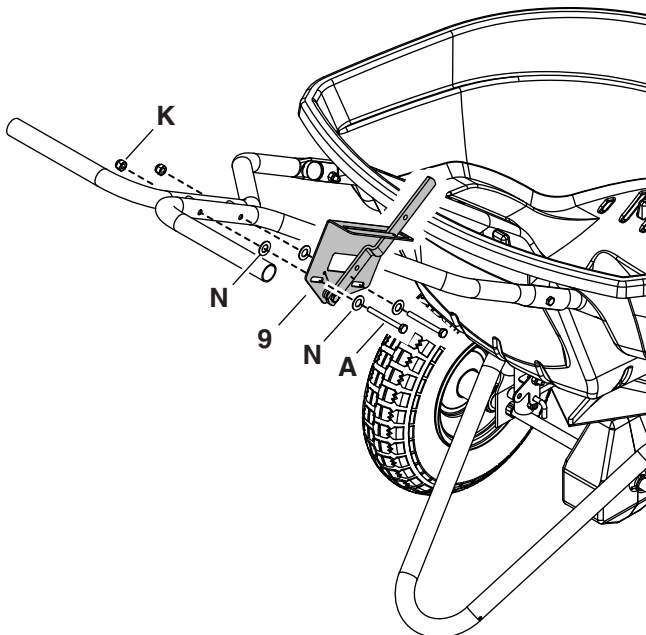

Assembly Step 15

Insert the lower end of the flow control rod (5) through the hole in the drive link bracket (Z) and then twist the rod so that the end points down.

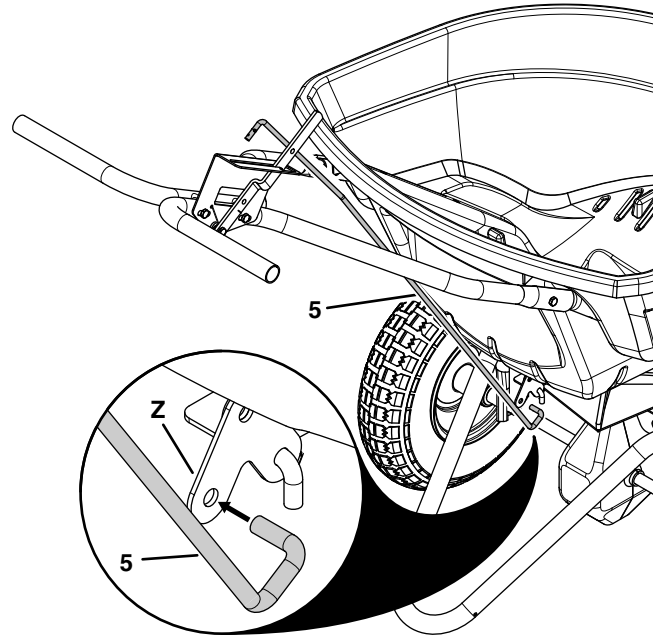

Assembly Step 16

Insert the upper end of the flow control rod (5) through the hole in the flow control arm. Secure it with a 1/4" washer (N) and a 3/32" x 3/4" cotter pin (I), spreading the ends of the cotter pin.

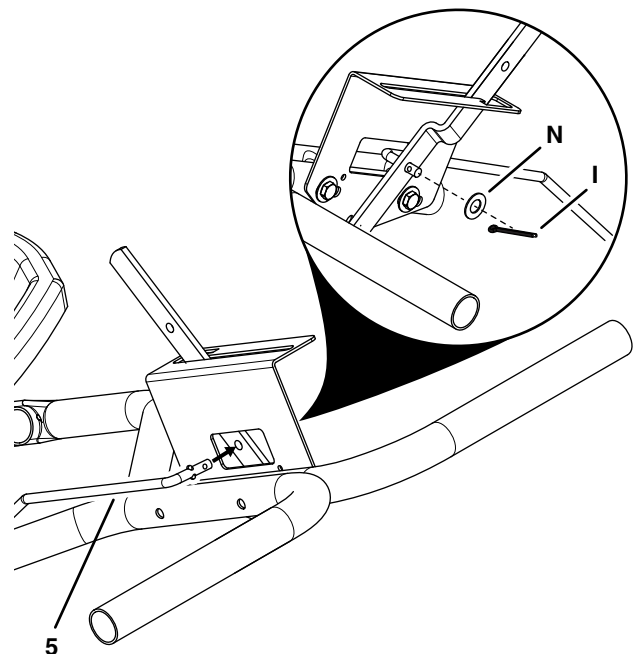

Assembly

Assembly Step 17

Install the grip (Y) onto the flow control arm.

Install the handle grips (BB) onto the handles.

Assemble the adjustable stop (S) to the flow control bracket using the 1/4" x 3/4" carriage bolt (F), nylon washer (L) and wing nut (R).

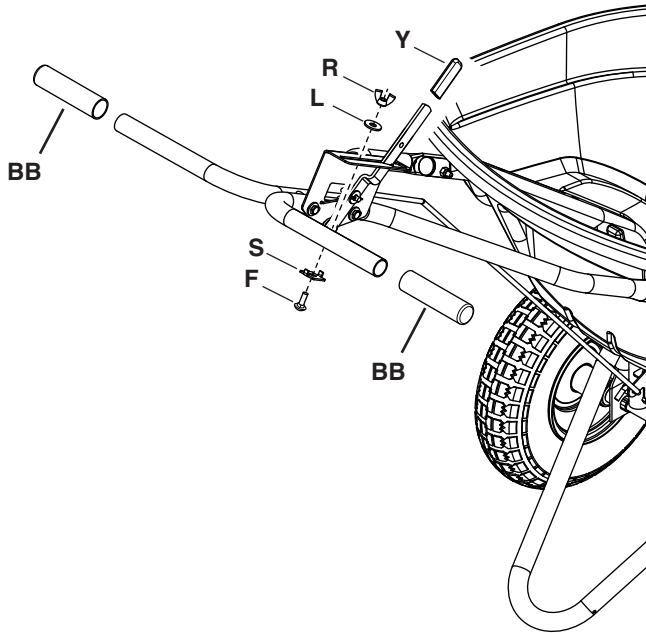

Assembly Step 18

Set the adjustable stop at "5" and move the control arm against it.

Slide the control bracket along the handle tube until the flow plate in the bottom of the hopper is open half way.

Tighten the bolts and nuts attaching the control bracket to the handle tubes. Do not indent the control bracket when tightening.

Make sure the flow plate is completely open at the highest setting and completely closed at the "OFF" setting. Re-adjust if necessary.

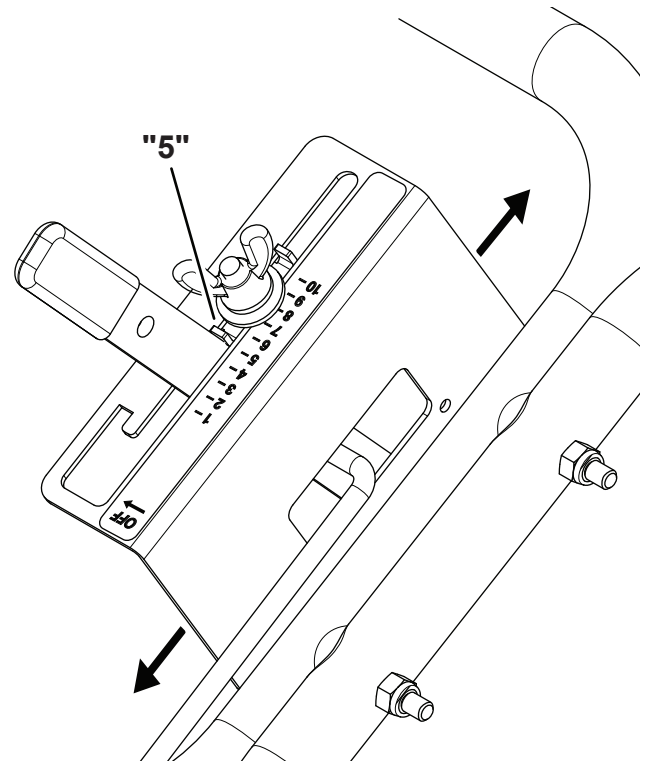

Operation

Setting The Flow Control

(Refer to Step 18 on Page 9.)

Loosen the wing nut, set the adjustable stop to the desired flow rate setting and retighten the wing nut. The higher the setting number, the wider the opening in the bottom of the hopper.

Refer to the application chart on this page and to the instructions on the fertilizer bag to select the proper flow rate setting.

Pull the flow control arm back against the adjustable stop for the on position. Push the flow control arm forward and then over into the locking notch for the off position.

Using Your Spreader

We do not recommend the use of any powdered lawn chemicals, due to difficulty in obtaining a satisfactory or consistent broadcast pattern.

Determine approximate square footage of area to be covered and estimate amount of material required.

Make sure the flow plate is closed.

Fill the hopper, breaking up any lumpy fertilizer.

Refer to the instructions on the fertilizer bag and to the application chart on this page to set the adjustable stop to the proper flow rate setting. The application chart is calculated for light to heavy application at a vehicle speed of 3 mph, or 100 ft. in 23 seconds. A variation in speed will require an adjustment of the flow rate to maintain the same coverage. The faster you walk, the wider the broadcast width.

Always start the spreader in motion before opening the flow plate.

Always close the flow plate before turning or stopping the spreader.

If fertilizer is accidentally deposited too heavily in a small area, soak the area thoroughly with a garden hose or sprinkler to prevent burning of the lawn.

To insure uniform coverage, make each pass so that the broadcast pattern slightly overlaps the pattern from the previous pass as shown in the drawing on this page. The approximate broadcast widths for different materials are shown in the application chart on this page.

When broadcasting weed control fertilizers, make sure the broadcast pattern does not hit evergreen trees, flowers or shrubs.

Heavy moisture conditions may require use of a vinyl hopper cover to keep contents dry. The cover acts as a wind and moisture shield, but should not be used as a rain cover. The #41316 cover can be ordered as an option. See pages 12 and 13.

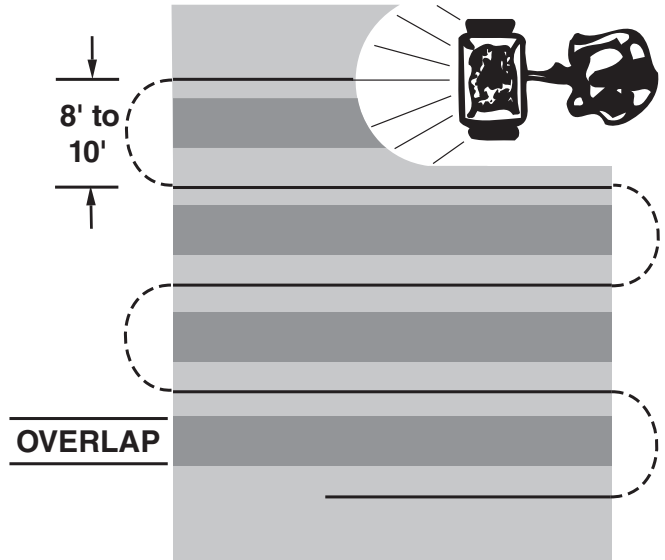

IMPORTANT: Application rates shown in the chart are affected by humidity and by the moisture content of the material (granular and pellet). Some minor setting adjustments may be necessary to compensate for this condition.

APPLICATION CHART

MATERIAL TYPE	FLOW SETTING	SPREAD WIDTH
<i>FERTILIZER</i>		
Powder	3 - 5	3' - 4'
Granular	3 - 5	8' - 10'
Pelleted	3 - 5	10' - 12'
Organic	6 - 8	6' - 8'
<i>GRASS SEED</i>		
Fine	3 - 4	6' - 7'
Coarse	4 - 5	8' - 9'
<i>ICE MELTER</i>		
	6 - 8	10' - 12'

Service and Troubleshooting

General Maintenance

Check For Loose Fasteners

Before each use, make a thorough visual check of the spreader for any bolts and nuts which may have loosened. Retighten any loose bolts and nuts.

Check For Worn Or Damaged Parts

Check for worn or damaged parts before each use. Repair or replace parts if necessary.

Check Tire Inflation

Check if tires are adequately inflated before each use. Do not inflate tires beyond maximum recommended pressure on tire.

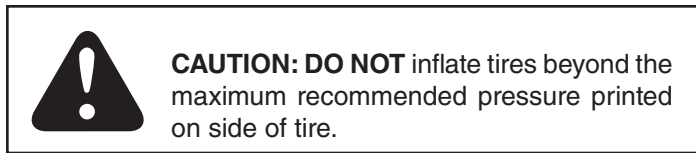

Storage

Rinse inside of hopper and exterior of spreader and allow to dry before storing.

Store in a clean, dry area.

Specifications

130 lb Spreader

Box Capacity0.07 cu meter (2.3 cu ft)

Maximum Load 59 kg (130 lb)

John Deere Quality Continues with Quality Service

John Deere provides a process to handle your questions or problems, should they arise, to ensure that product quality continues with quality parts and service support.

Follow the steps below to get answers to any questions you may have about your product.

1. Refer to your attachment and machine operator manuals.
2. In North America or Canada, call Agri-Fab, Inc. Customer Service at 1-800-448-9282 and provide product serial number (if available) and model number.

This product was manufactured by Agri-Fab, Inc., a John Deere Licensee, located at 809 South Hamilton, Sullivan, Illinois, 61951. If you have any questions or concerns with the assembly, installation or operation of this attachment see your local John Deere Dealer or call Agri-Fab, Inc. at 1-800-448-9282 for assistance.

Service And Adjustments

If the axle and gear assembly is disassembled, mark down the positions of the parts as they are removed. The drive wheel and large gear positions, in relation to the small gear, determine which direction the impeller will spin. Be sure to reassemble all parts in their original positions. (Refer to the exploded parts view on page 12). Apply fresh grease to the gears when re-assembling.

Cleaning

Rinse inside of hopper and exterior of spreader and allow to dry before storing.

Lubricate

Remove the three clips from the gear box and separate the gearbox housings.

Lightly apply automotive grease as needed to the gears.

Lightly oil the top of the gear box and the vertical spreader shaft.

Re-assemble the gearbox housings and secure them with the clips.

Oil the (idler) wheel and the axle bushings at least once a year or more often as needed.

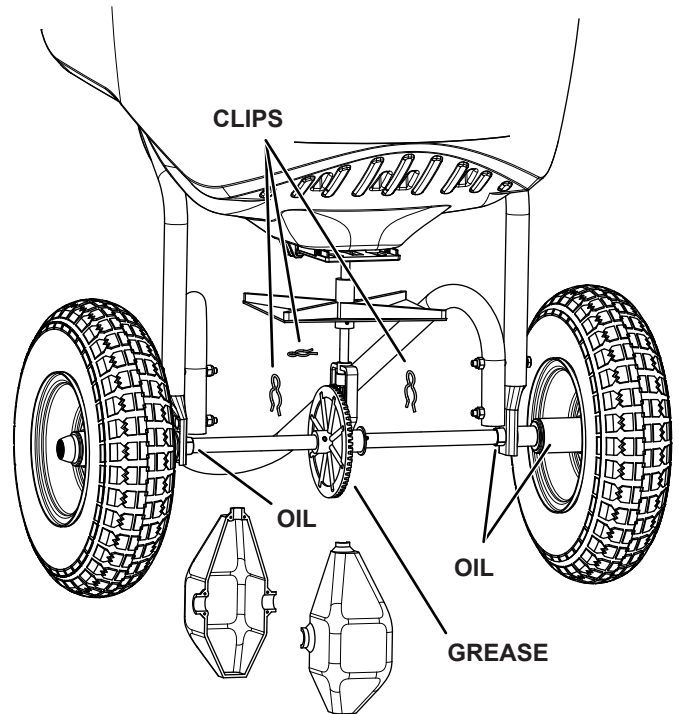

LP# 67699 Repair Parts

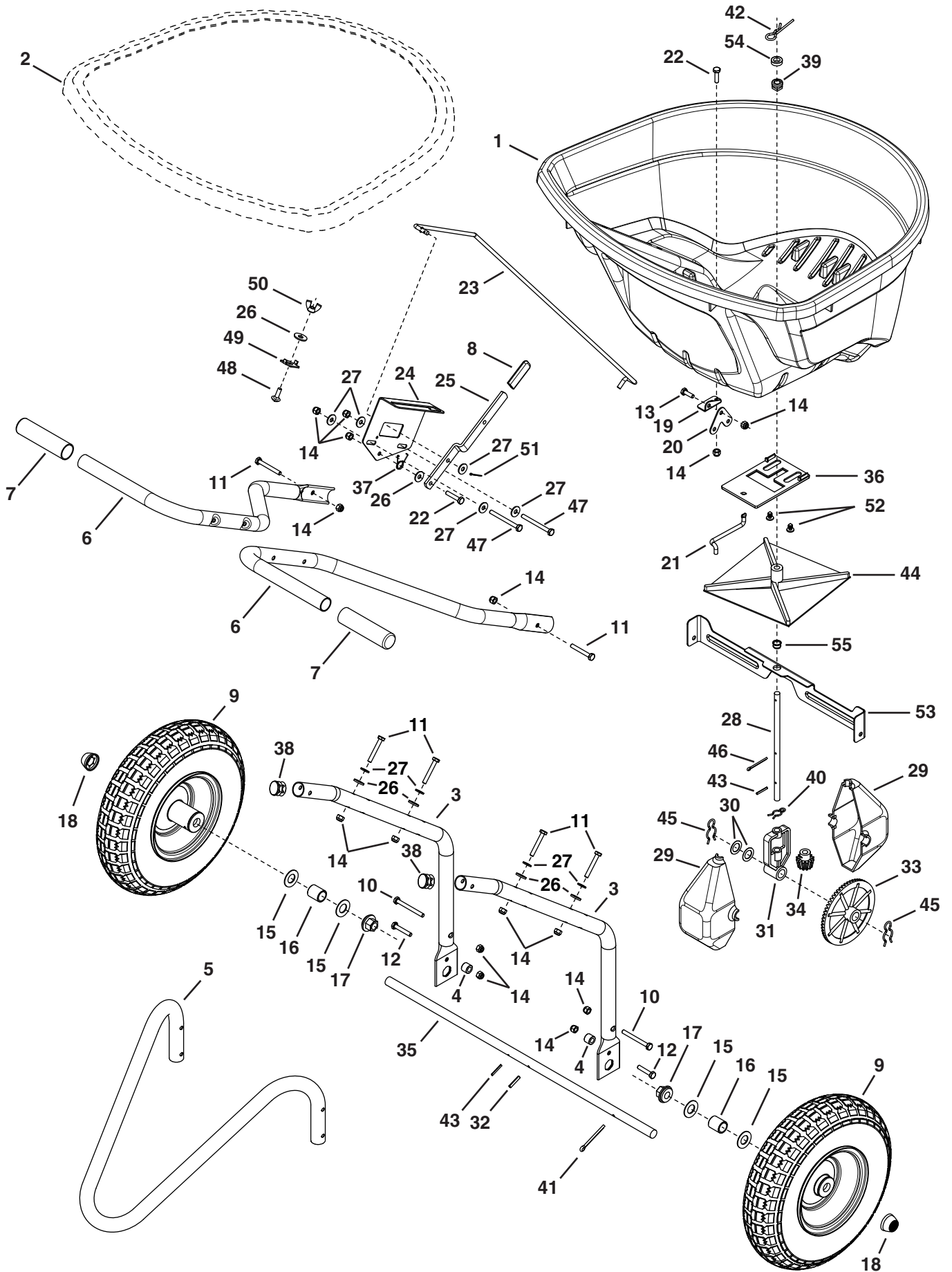

LP# 67699 Repair Parts

REF	QTY	PART NO	DESCRIPTION	REF	QTY	PART NO	DESCRIPTION
1	1	41084G	Hopper	31	1	47204	Yoke, Large
2	1	41316	Hopper Cover (Optional)	32	1	43659	Pin, Spring 3/16 x 1
3	2	28383	Tube, Hopper Support	33	1	47209	Gear, Large
4	2	28325	Spacer, .31" x .56" x .438"	34	1	47205	Gear, Small
5	1	42004	Tube, Stand	35	1	26710	Axle
6	2	41924	Tube, T-Handle	36	1	42304	Plate, Flow
7	2	44482	Grip, Handle	37	1	42347	Spring, Torsion
8	1	43848	Grip, Control Arm	38	2	49449	Plug
9	2	40880Y	Wheel	39	1	44285	Bushing, Hopper Bottom Black
10	2	49870	Bolt, Hex 1/4-20 x 2-1/2	40	1	49898	Clip, Hairpin 5/8
11	6	1509-69	Bolt, Hex 1/4-20 x 1-3/4	41	1	46855	Pin, Cotter 3/16" x 2"
12	2	46699	Bolt, Hex 1/4-20 x 2	42	1	48934	Hairpin, Agitator
13	1	43012	Bolt, Hex 1/4-20 x 3/4	43	2	46055	Pin, Spring 1/8 x 1
14	15	47189	Nut, Hex 1/4-20 Nylock	44	1	04367	Spreader Impeller
15	4	R19212016	Washer, .6562 x 1.25 x .0598	45	2	49897	Clip, Hairpin 7/8
16	2	45280	Spacer, .64 ID x .88 OD x .625	46	1	43093	Pin, Cotter 1/8 x 1-1/2
17	2	45279	Bushing, Hex	47	2	43796	Bolt, Hex 1/4-20 x 2-3/4
18	2	48499B	Hub Cap	48	1	44950	Bolt, Carriage 1/4-20 x 3/4
19	1	27276	Bracket, Drive Link Mount	49	1	24858	Adjustable Stop
20	1	27277	Bracket, Drive Link	50	1	47141	Nut, Nylon Wing 1/4-20
21	1	41929	Rod, Drive Link	51	1	44101	Pin, Cotter 3/32 x 3/4
22	2	43661	Bolt, Hex 1/4-20 x 1	52	2	48402	Plug, 1/4" (Christmas Tree)
23	1	41928	Rod, Flow Control	53	1	27313	Cross Brace
24	1	27322	Bracket, Flow Control	54	1	23625	Spacer
25	1	24856	Arm, Flow Control	55	1	42839	Bushing, 3/8" Plastic
26	6	1543-69	Washer, Nylon .3281 x .75	56	1	68881	Transmission Assembly - not shown (includes 28, 29, 30, 31, 32, 33, 34, 35, 40, 43, & 45)
27	9	43088	Washer, 1/4 Std .312 x .734 x .065				
28	1	28390	Shaft, Spreader				
29	2	47212	Housing, Large Gear		1	45383 CC2	Owner's Manual
30	2	44125	Washer, .625 x 1.0 x .03				

LIMITED WARRANTY FOR NEW JOHN DEERE LICENSED PRODUCTS

WHO IS COVERED: This Warranty covers only the original retail purchaser of a John Deere consumer product or service part manufactured under license by Agri-Fab, Inc. It is not transferable.

HOW LONG DOES COVERAGE LAST: This Warranty remains in force for 2 years from the date of purchase; provided, however, that if the product is used commercially the Warranty remains in force for only 90 days from the date of purchase.

WHAT IS COVERED: Any defect in material or workmanship of your John Deere product or part.

WHAT IS NOT COVERED: Damage caused by misuse, excessive use, accident, neglect, alterations or operation or maintenance other than in accordance with instructions. This Warranty also does not cover the engine, if applicable, which may be covered by a separate limited warranty provided by the engine manufacturer, or any parts which may need to be replaced due to normal use of the product such as, but not limited to, belts and tires.

During the first year of ownership of the product, the current warranty will not change. For the second year of ownership the items listed below are not covered by or under the two (2) year limited warranty as they are considered "Wear Parts".

Category	Items excluded from Year 2 of the Warranty
8 Y Poly Cart	wheels/bearing
130 lb. Push & Tow Spreader	hopper bearing/wheels/bearings
44 in. Lawn Sweeper	bag/brushes/wheels
Multi-Tool	wheels

WHAT WE WILL DO: Repair or replace your John Deere product or part.

HOW TO GET SERVICE: Deliver the John Deere product or part to a John Deere Dealer or contact the customer support at 1-800-448-9282. The return of a product or part to the manufacturer will not be accepted unless prior written permission has been extended by Agri-Fab.

THE DURATION OF ANY IMPLIED WARRANTY OF MERCHANTABILITY IS LIMITED TO THE DURATION OF THE ABOVE EXPRESS WARRANTY. THE REMEDIES PROVIDED IN THIS LIMITED WARRANTY ARE THE CUSTOMER'S SOLE AND EXCLUSIVE REMEDIES. EXCEPT FOR THE OBLIGATIONS SPECIFICALLY SET FORTH IN THIS LIMITED WARRANTY, IN NO EVENT SHALL AGRI-FAB BE LIABLE FOR INCIDENTAL OR CONSEQUENTIAL DAMAGES, WHETHER BASED ON CONTRACT, TORT, OR ANY OTHER LEGAL THEORY. Some states do not allow limitations on how long an implied warranty lasts, or the exclusion or limitation of incidental or consequential damages, so the above limitations may not apply to you.

This Warranty gives you specific legal rights, and you may also have other rights which vary from state to state.

Customer Support Phone # 800-448-9282 Mon.-Fri. 7 am – 5 pm CST