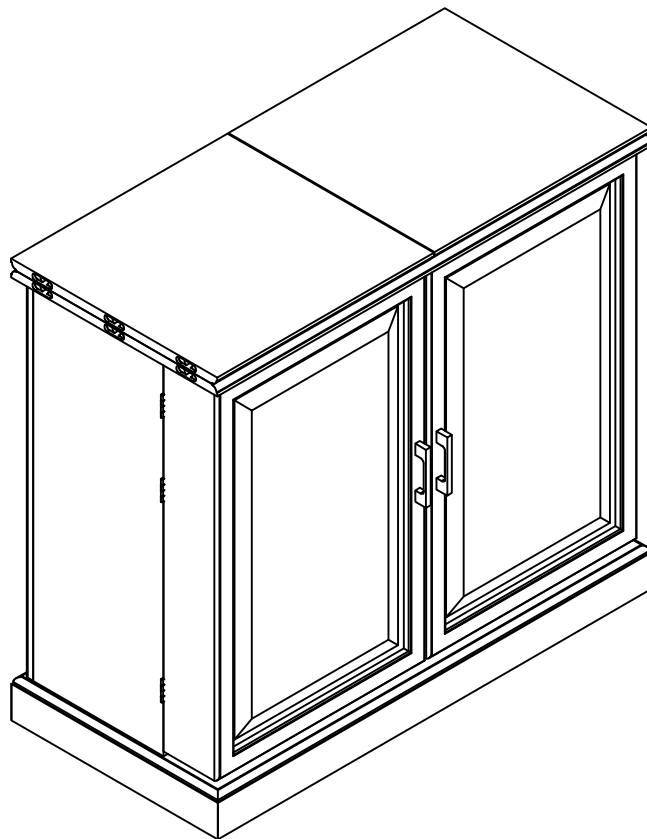


# HOME DECORATORS COLLECTION

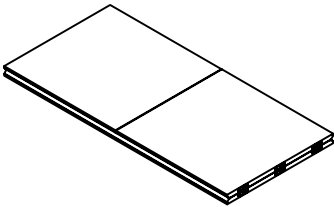
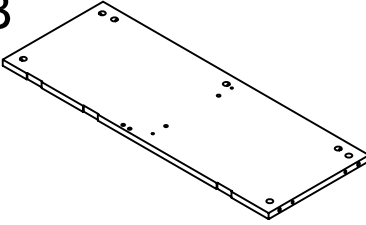
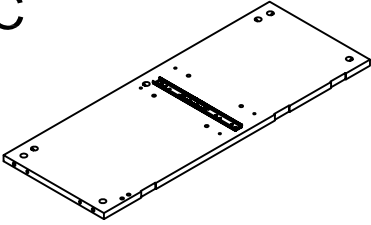
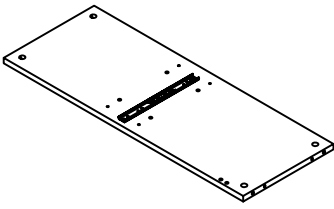
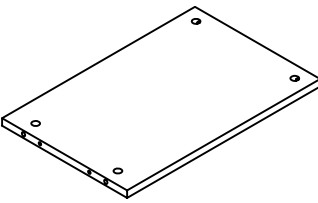
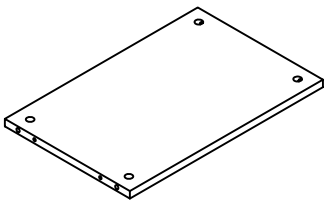
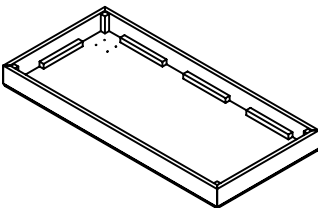
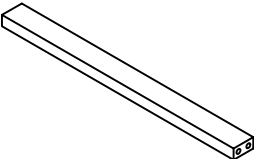
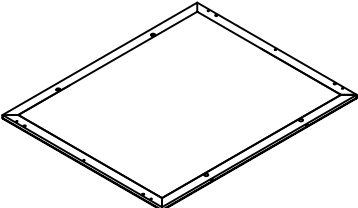
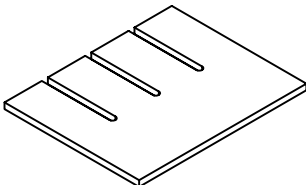
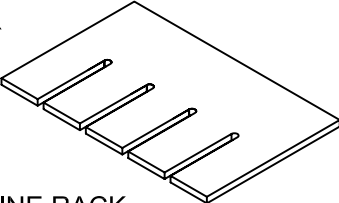
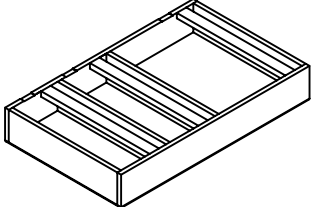
INV# 74008  
SK18215A JAMISON CONCEALED BAR 37"Hx40"Wx19"D  
ASSEMBLY INSTRUCTIONS

Made In China



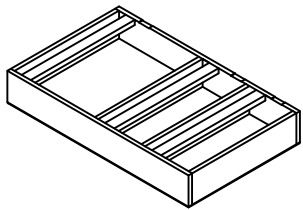
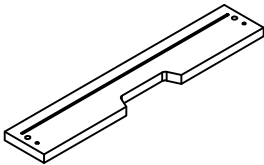
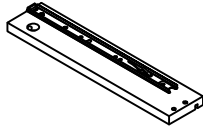
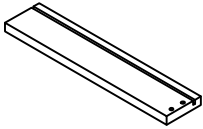
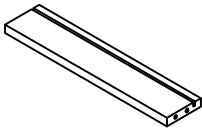
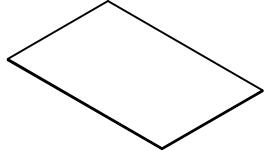
Thank you for purchasing this quality product. Be sure to check all packing material carefully for small parts, which may have come loose inside the carton during shipment. Count all parts and material hardware, then compare with parts list to be sure all parts are present. If any parts are missing or damaged, please contact our Customer Service Department for efficient and speedy service. Please indicate the model number and code letter of part(s) needed.

**IMPORTANT NOTE:** Follow instructions listed below in proper sequence as numbered to assure fast, easy and correct assembly.

<b>PARTS LIST</b>		
<b>A</b> 	<b>B</b> 	<b>C</b> 
TOP PANEL-1PC	LEFT SIDE PANEL-1PC	RIGHT SIDE PANEL-1PC
<b>D</b> 	<b>E</b> 	<b>F</b> 
MIDDLE PANEL-1PC	LEFT SIDE FIXED PANEL-1PC	RIGHT SIDE FIXED PANEL-2PCS
<b>G</b> 	<b>H</b> 	<b>I</b> 
BOTTOM PANEL-1PC	CROSS BRACE-2PCS	BACK PANEL-1PC
<b>J</b> 	<b>K</b> 	<b>L</b> 
WINE RACK VERTICAL PANEL-4PCS	WINE RACK LEVEL PANEL-3PCS	LEFT SIDE DOOR BOX-1PC

Thank you for purchasing this quality product. Be sure to check all packing material carefully for small parts, which may have come loose inside the carton during shipment. Count all parts and material hardware, then compare with parts list to be sure all parts are present. If any parts are missing or damaged, please contact our Customer Service Department for efficient and speedy service. Please indicate the model number and code letter of part(s) needed.

**IMPORTANT NOTE:** Follow instructions listed below in proper sequence as numbered to assure fast, easy and correct assembly.

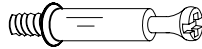
<b>PARTS LIST</b>		
<b>M</b>  RIGHT SIDE DOOR BOX-1PC	<b>N</b>  DRAWER FRONT PANEL-1PC	<b>O</b>  DRAWER LEFT SIDE PANEL-1PC
<b>P</b>  DRAWER RIGHTSIDE PANEL-1PC	<b>Q</b>  DRAWER BACK PANEL-1PC	<b>R</b>  DRAWER BOTTOM PANEL-1PC

a



WOOD DOWEL-38PCS

b



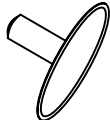
CAM  
LOCK BOLT-36PCS

c



CAM LOCK-36PCS

d



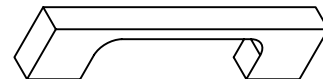
LONG  
PLASTIC COVER-22PCS

e



1/2" FLAT  
HEAD SCREW-36PCS

f



HANDLE-2PCS

g



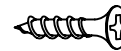
HANDLE BOLT-4PCS

h



1" FLAT  
HEAD SCREW-4PCS

i



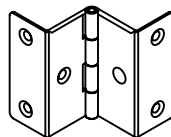
5/8" FLAT  
HEAD SCREW-16PCS

j



UNIVERSAL WHEEL-4PCS

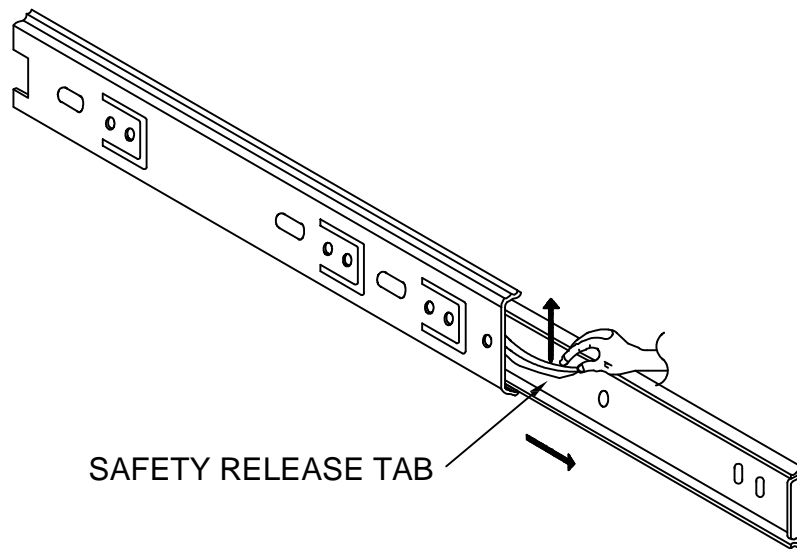
k



HINGE-6PCS

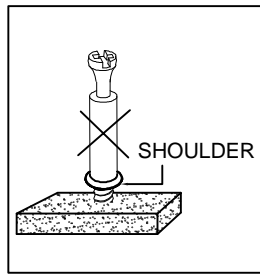
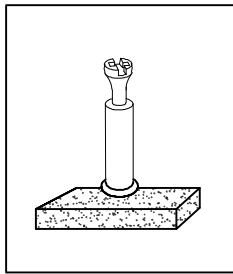
NOTE:THE SURFACE WITH THE STICKER IS THE BACK SIDE

## HOW TO SEPARATE GLIDES



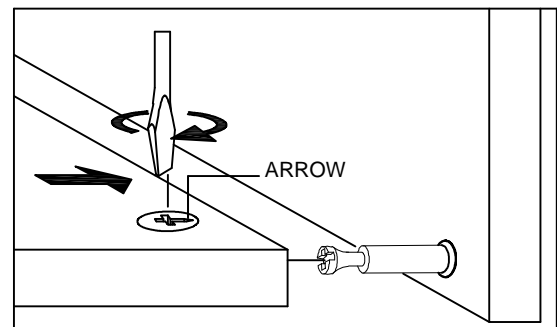
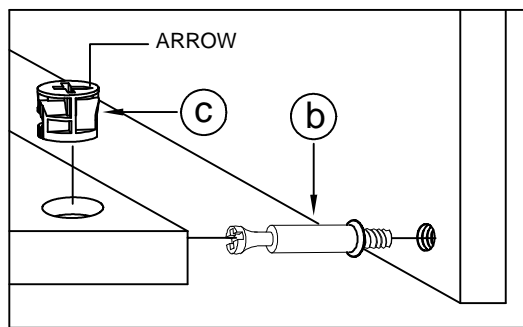
PRIOR TO ASSEMBLY, WE SUGGEST SEPARATING THE INNER GLIDES FROM THE OUTER-GLIDES, SIMPLY PULL THE LEFT/RIGHT INNER GLIDES FROM THE OUTER GLIDES EXPOSING A SMALL BLACK SAFETY RELEASE TAB, BY PUSHING THE SAFETY RELEASE TAB. YOU WILL BE ABLE TO SEPARATE THE GLIDES.

NOTE: • UPON OPENING, THOROUGHLY CLEAN ALL WOOD SURFACES TO REMOVE DUST AND DIRT THAT MAY HAVE SETTLED ONTO THE FINISH DURING SHIPMENT. IN ORDER TO PREVENT DAMAGE DURING ASSEMBLY. PLEASE ASSEMBLE THIS ITEM WITH AT LEAST TWO PEOPLE.



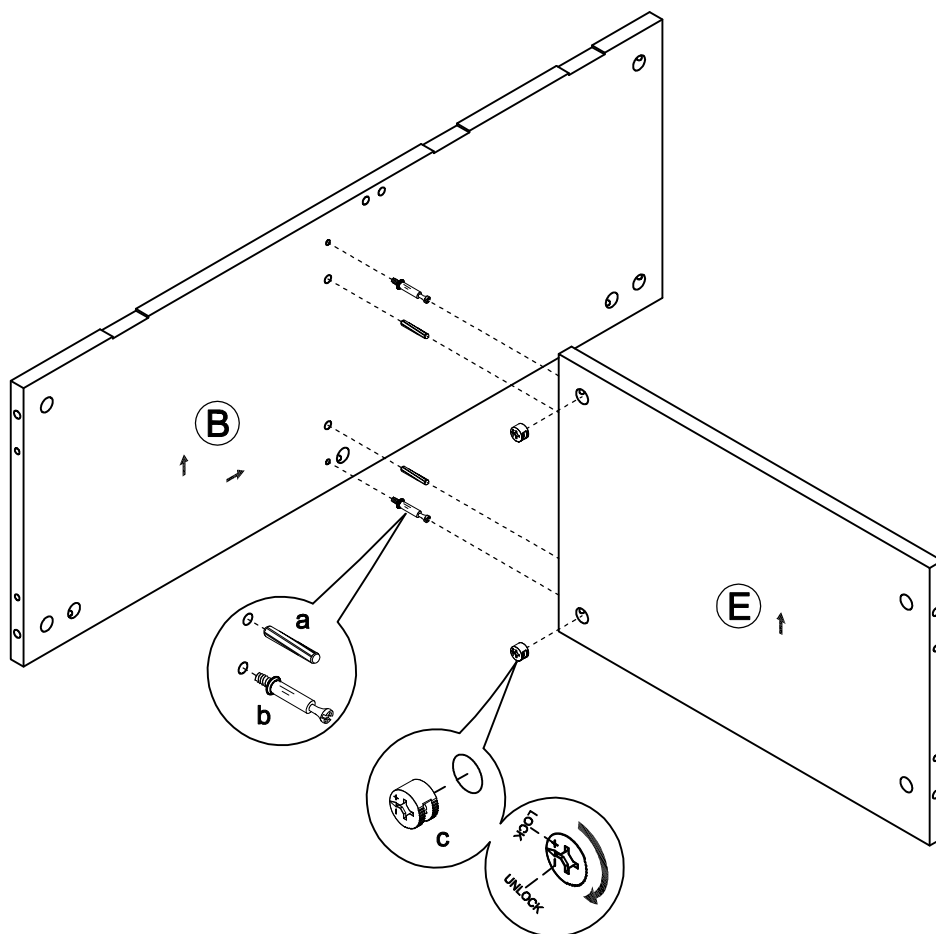
NOTE: TURN THE CAM-BOLT SCREWS UNTIL THEY ARE TIGHT, THE SHOULDER SHOULD BE AGAINST THE SURFACE OF THE PART.

## HOW TO USE THE CAM-TOOL



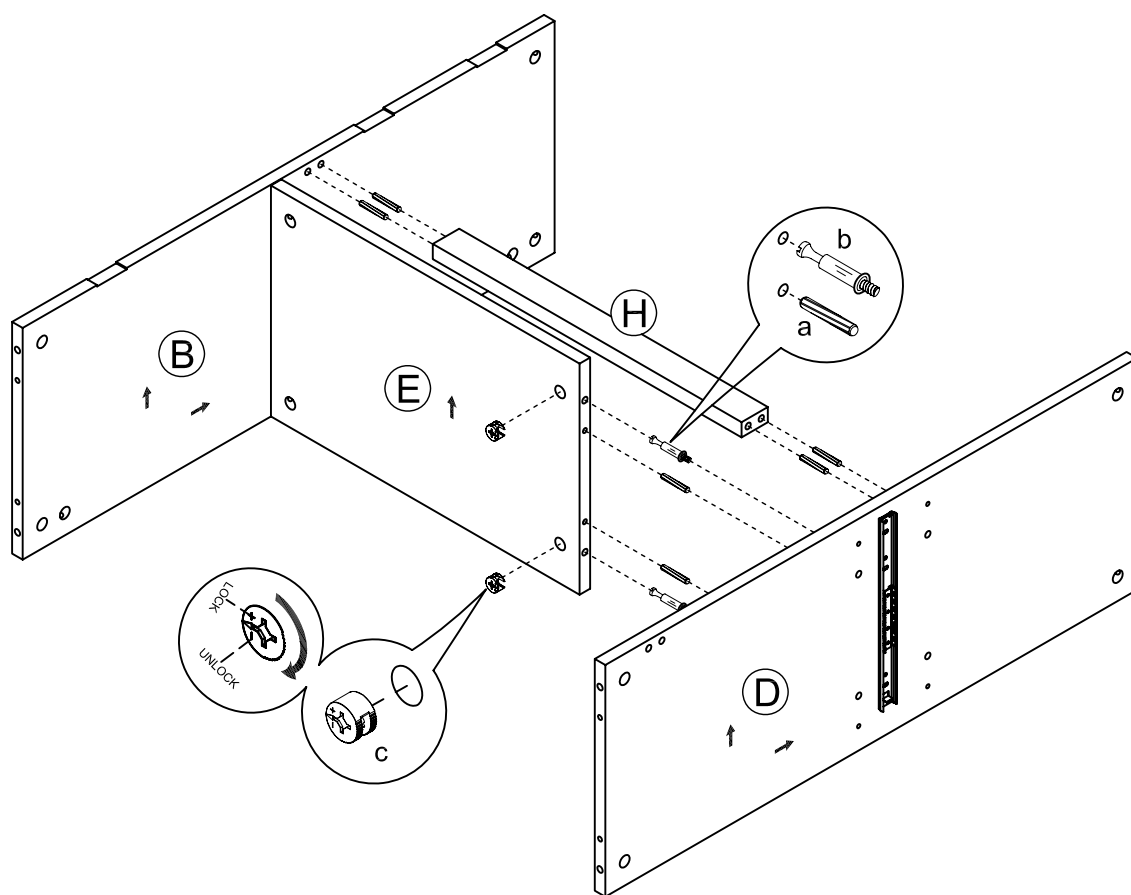
NOTE: • THE ARROWS ON THE HIDDEN CAM-LOCKS SHOULD POINT TO THE CAM-BOLTS.

# FIG 1



- INSTALL THE WOOD DOWEL (a) AND THE CAM LOCK BOLT (b) INTO THE LEFT SIDE PANEL (B).
- JOIN THE LEFT SIDE PANEL (B) TO THE LEFT SIDE FIXED PANEL (E)  
BY USING WOOD DOWEL (a) FIRST.
- TIGHTEN THE CAM LOCK BOLT (b) WITH THE CAM LOCK (c) FROM PRE-DRILLED HOLES.

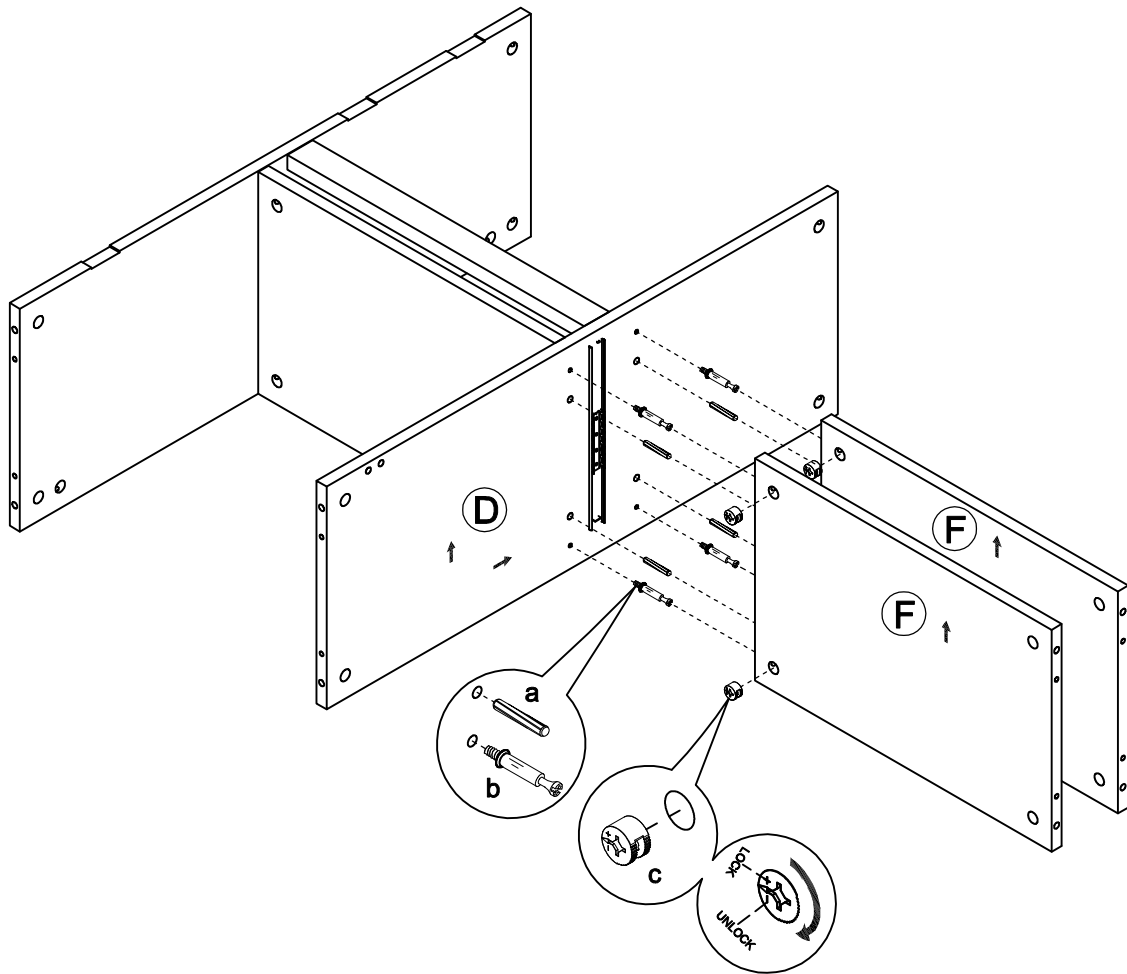
# FIG 2



- INSTALL THE WOOD DOWEL (a) INTO THE LEFT SIDE PANEL (B).
- INSTALL THE WOOD DOWEL (a) AND THE CAM LOCK BOLT (b) INTO THE MIDDLE PANEL (D).
- JOIN THE CROSS BRACE (H) TO THE LEFT SIDE PANEL (B). JOIN THE MIDDLE PANEL (D) TO THE LEFT SIDE FIXED PANEL (E) AND THE CROSS BRACE (H) BY USING WOOD DOWEL (a) FIRST.
- TIGHTEN THE CAM LOCK BOLT (b) WITH THE CAM LOCK (c) FROM PRE-DRILLED HOLES.

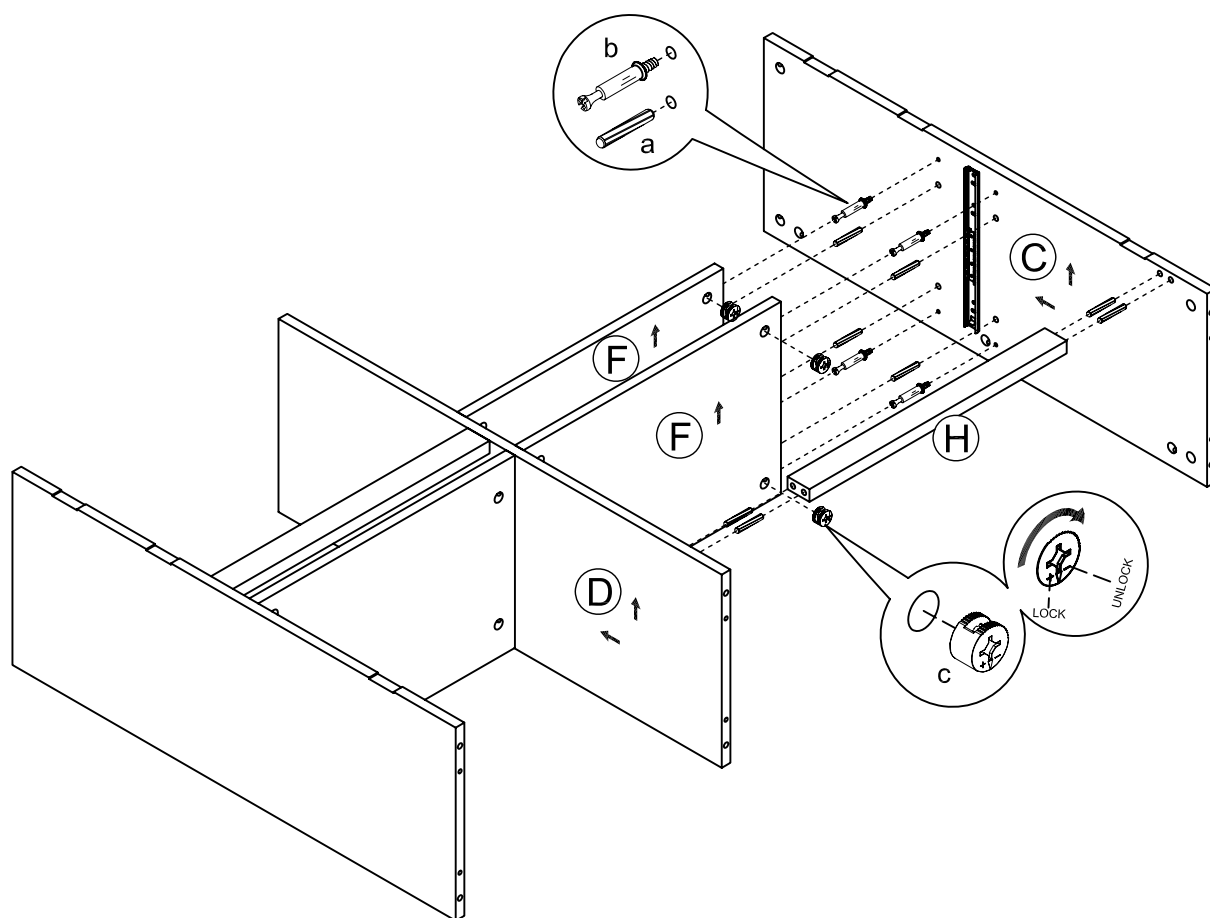


# FIG 3



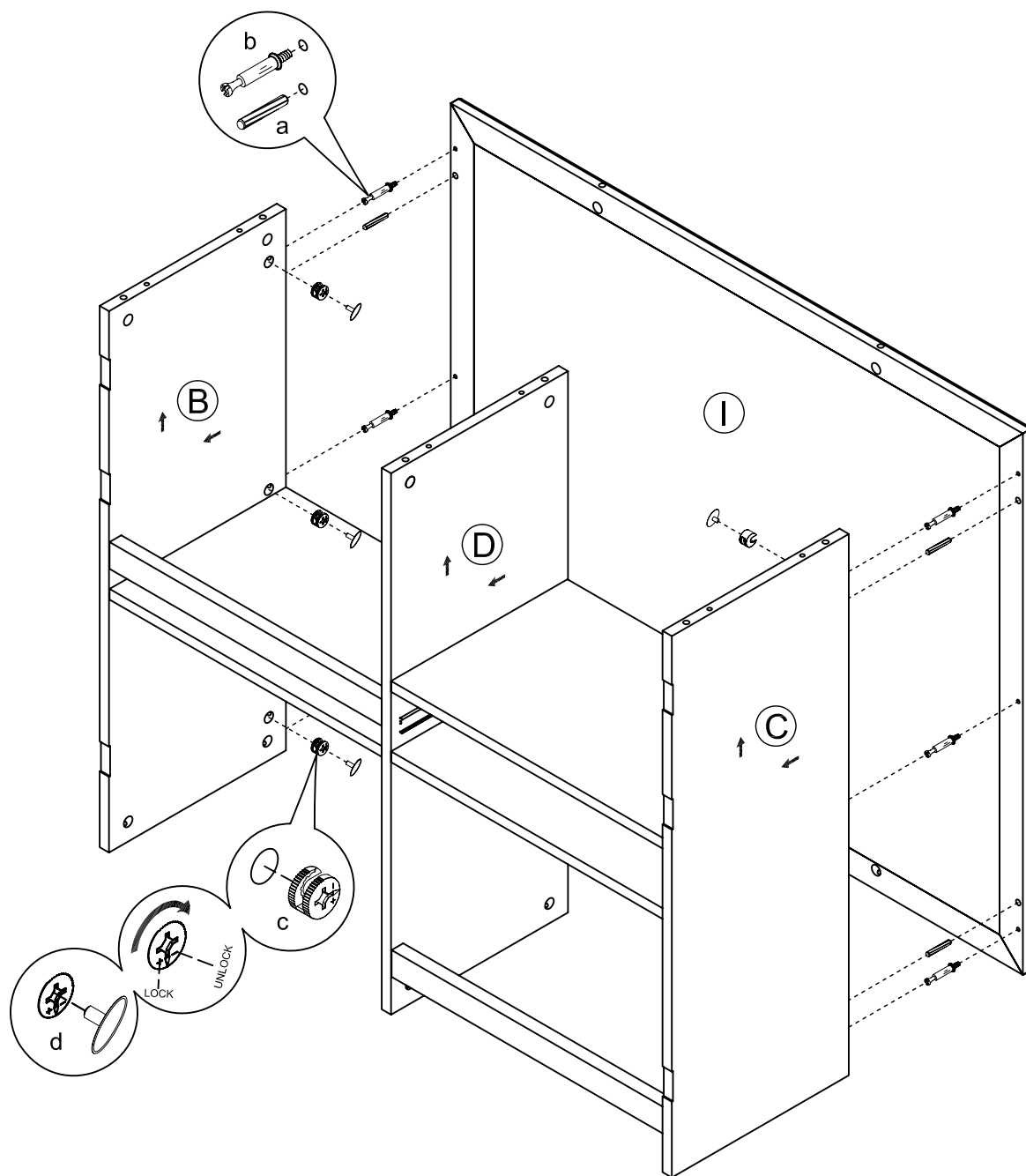
- INSTALL THE WOOD DOWEL (a) AND THE CAM LOCK BOLT (b) INTO THE MIDDLE PANEL (D).
- JOIN THE RIGHT SIDE FIXED PANEL (F) TO THE MIDDLE PANEL (D) BY USING WOOD DOWEL (a) FIRST.
- TIGHTEN THE CAM LOCK BOLT (b) WITH THE CAM LOCK (c) FROM PRE-DRILLED HOLES.

# FIG 4



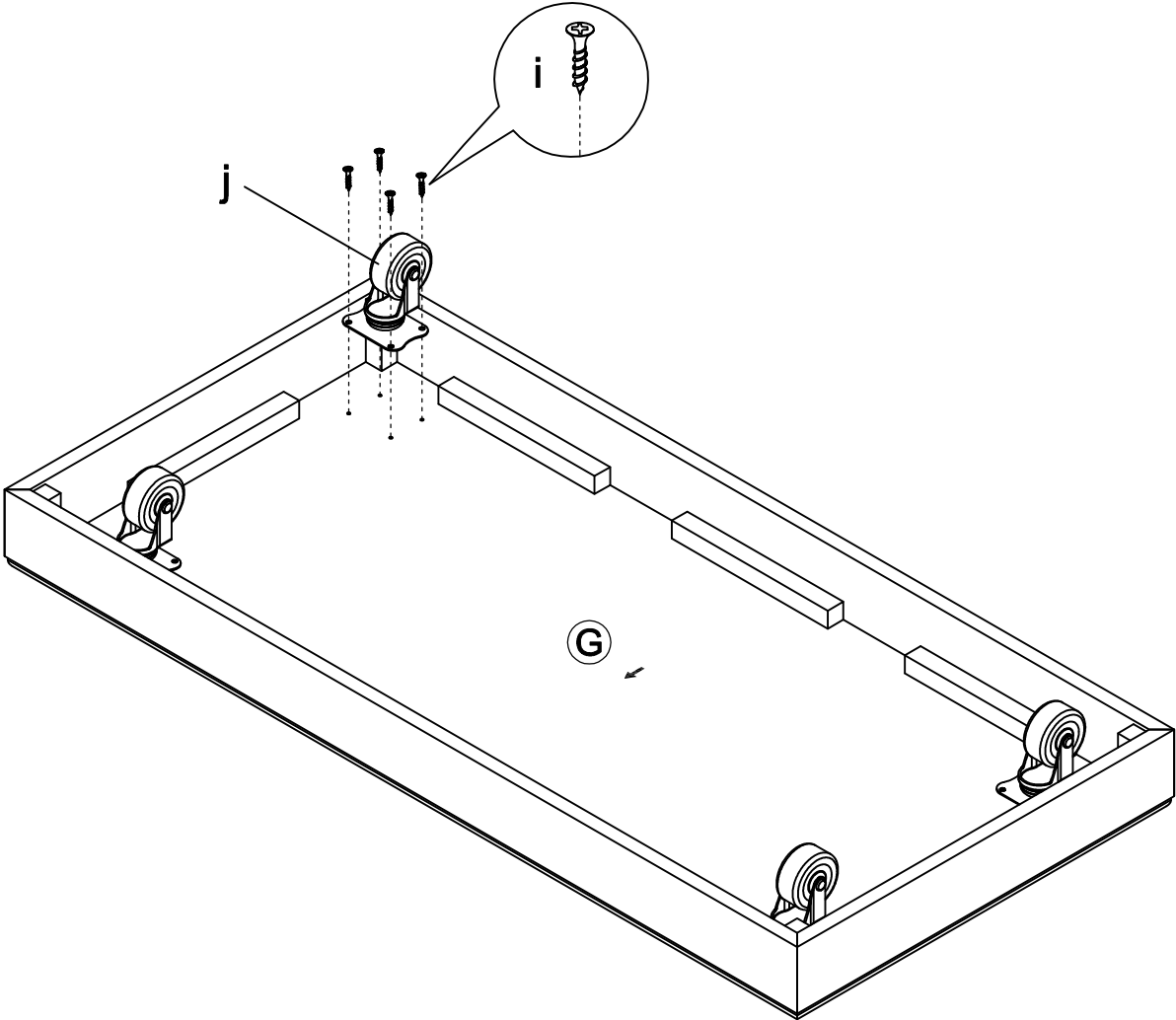
- INSTALL THE WOOD DOWEL (a) INTO THE MIDDLE PANEL (D).
- INSTALL THE WOOD DOWEL (a) AND THE CAM LOCK BOLT (b) INTO THE RIGHT SIDE PANEL (C).
- JOIN THE CROSS BRACE (H) TO THE MIDDLE PANEL (D). JOIN THE RIGHT SIDE PANEL (C) TO THE RIGHT SIDE FIXED PANEL (F) AND THE CROSS BRACE (H) BY USING WOOD DOWEL (a) FIRST.
- TIGHTEN THE CAM LOCK BOLT (b) WITH THE CAM LOCK (c) FROM PRE-DRILLED HOLES.

# FIG 5



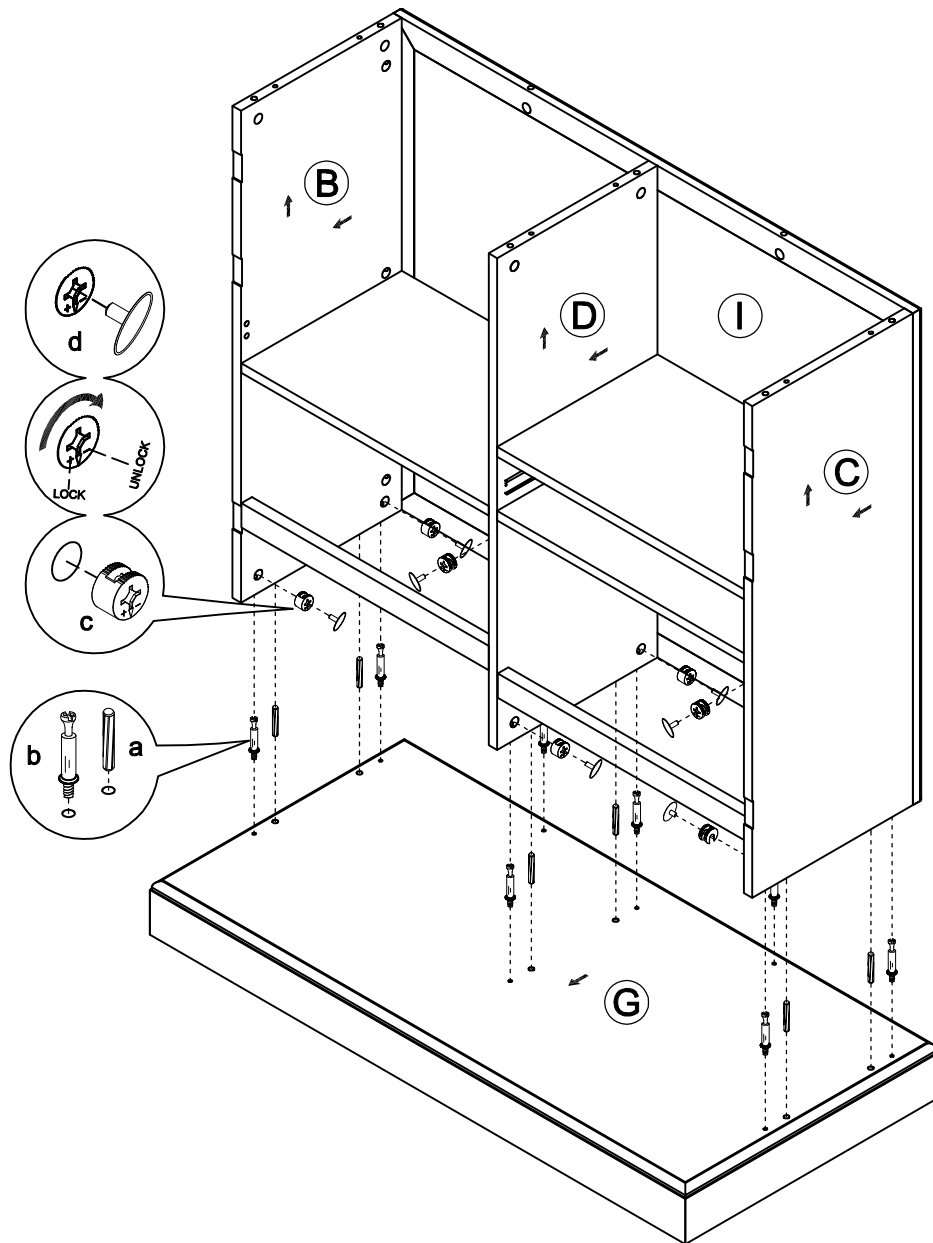
- INSTALL THE WOOD DOWEL (a) AND THE CAM LOCK BOLT (b) INTO THE BACK PANEL (I).
- JOIN THE BACK PANEL (I) TO THE LEFT SIDE PANEL (B) THE RIGHT SIDE PANEL (C) AND THE MIDDLE PANEL (D) BY USING WOOD DOWEL (a) FIRST.
- TIGHTEN THE CAM LOCK BOLT (b) WITH THE CAM LOCK (c) FROM PRE-DRILLED HOLES.
- COVER THE CAM HOLES WITH PLASTIC COVER (d).

FIG 6



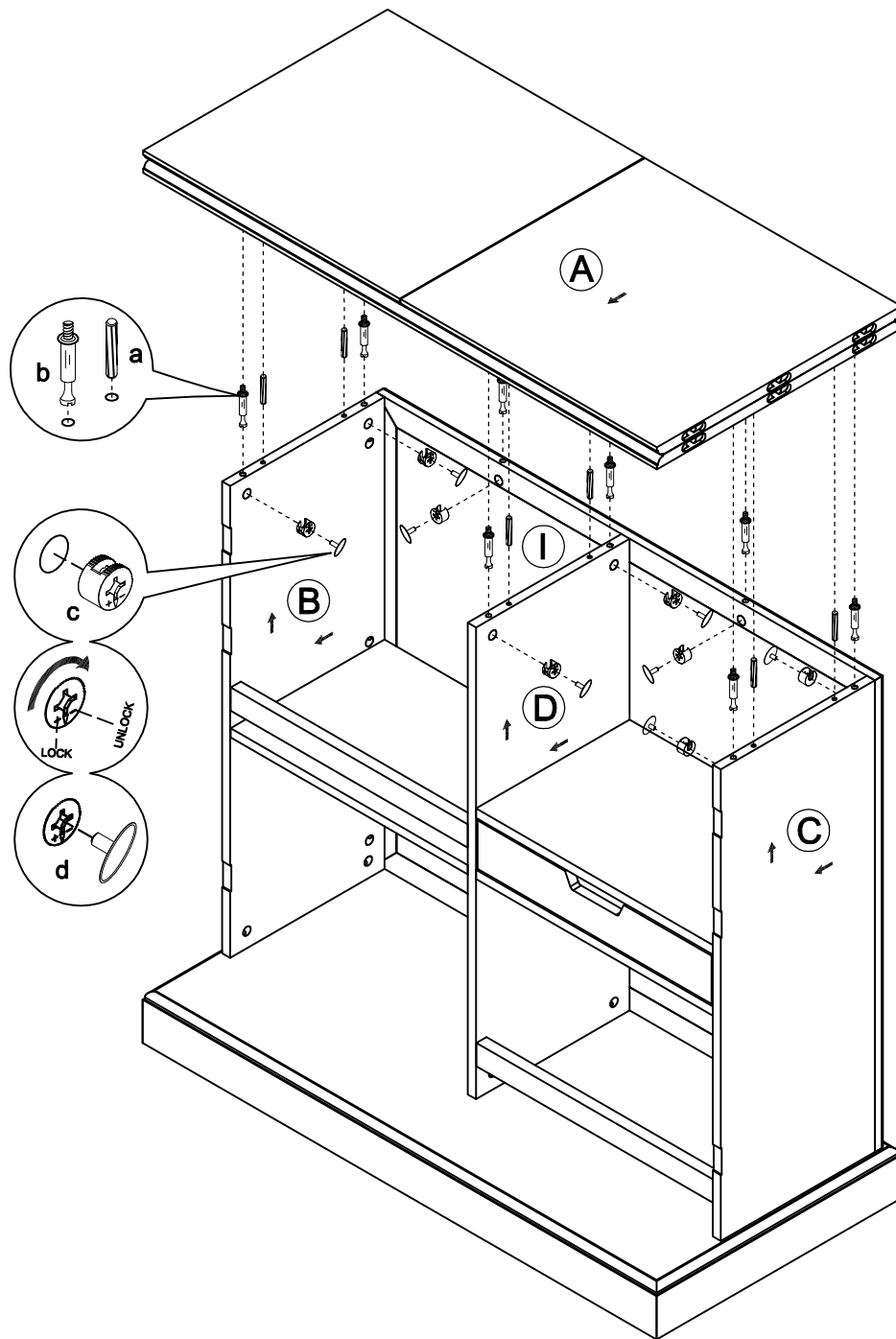
- JOIN THE UNIVERSAL WHEEL ( j ) TO THE BOTTOM PANEL ( G ) BY USING 5/8" FLAT HEAD SCREW ( i ) FIRST.

# FIG 7



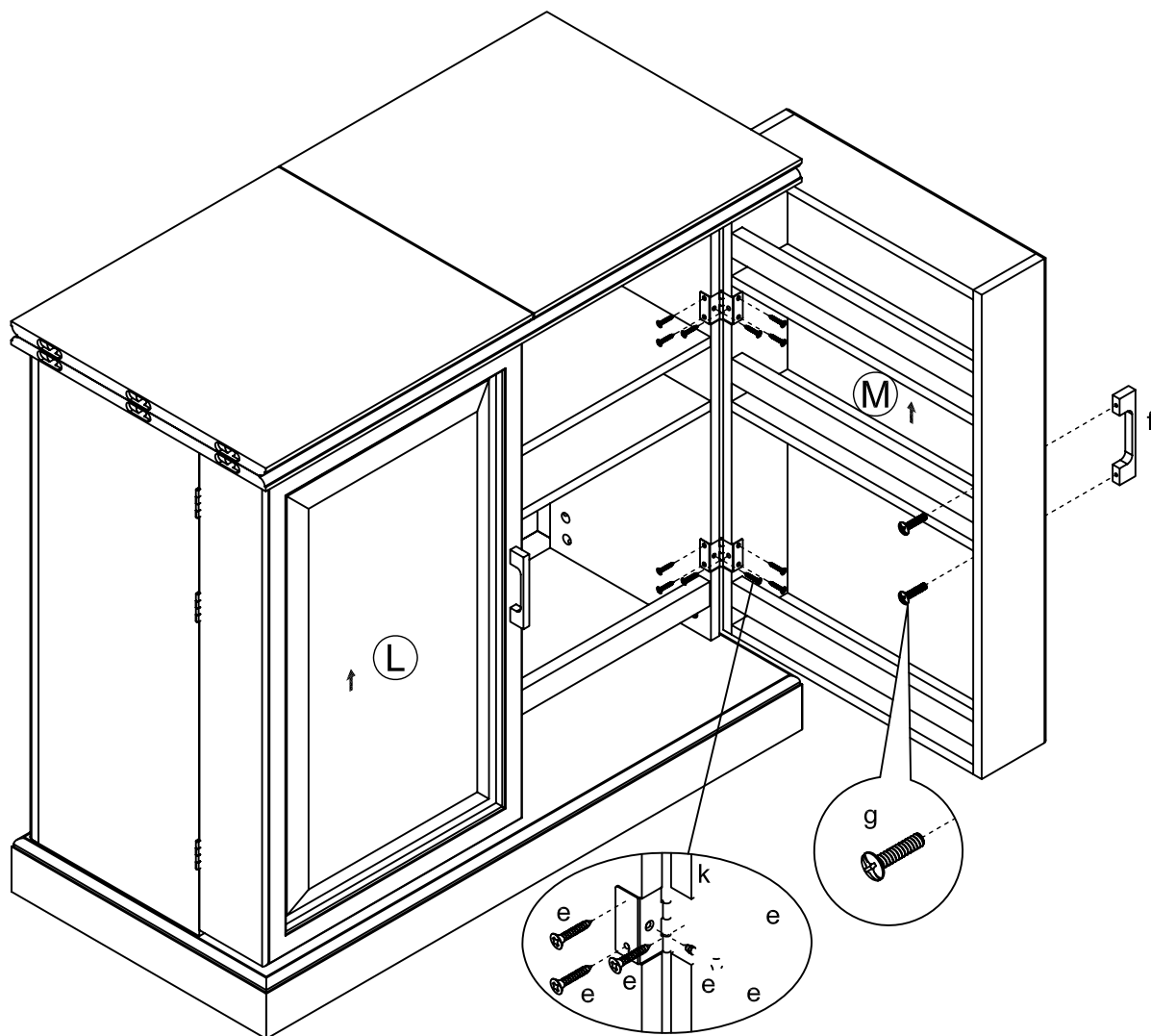
- INSTALL THE WOOD DOWEL (a) AND THE CAM LOCK BOLT (b) INTO THE BOTTOM PANEL (G).
- JOIN THE BOTTOM PANEL (G) TO THE ASSEMBLED PART BY USING WOOD DOWEL (a) FIRST.
- TIGHTEN THE CAM LOCK BOLT (b) WITH THE CAM LOCK (c) FROM PRE-DRILLED HOLES.
- COVER THE CAM HOLES WITH PLASTIC COVER (d).

# FIG 8



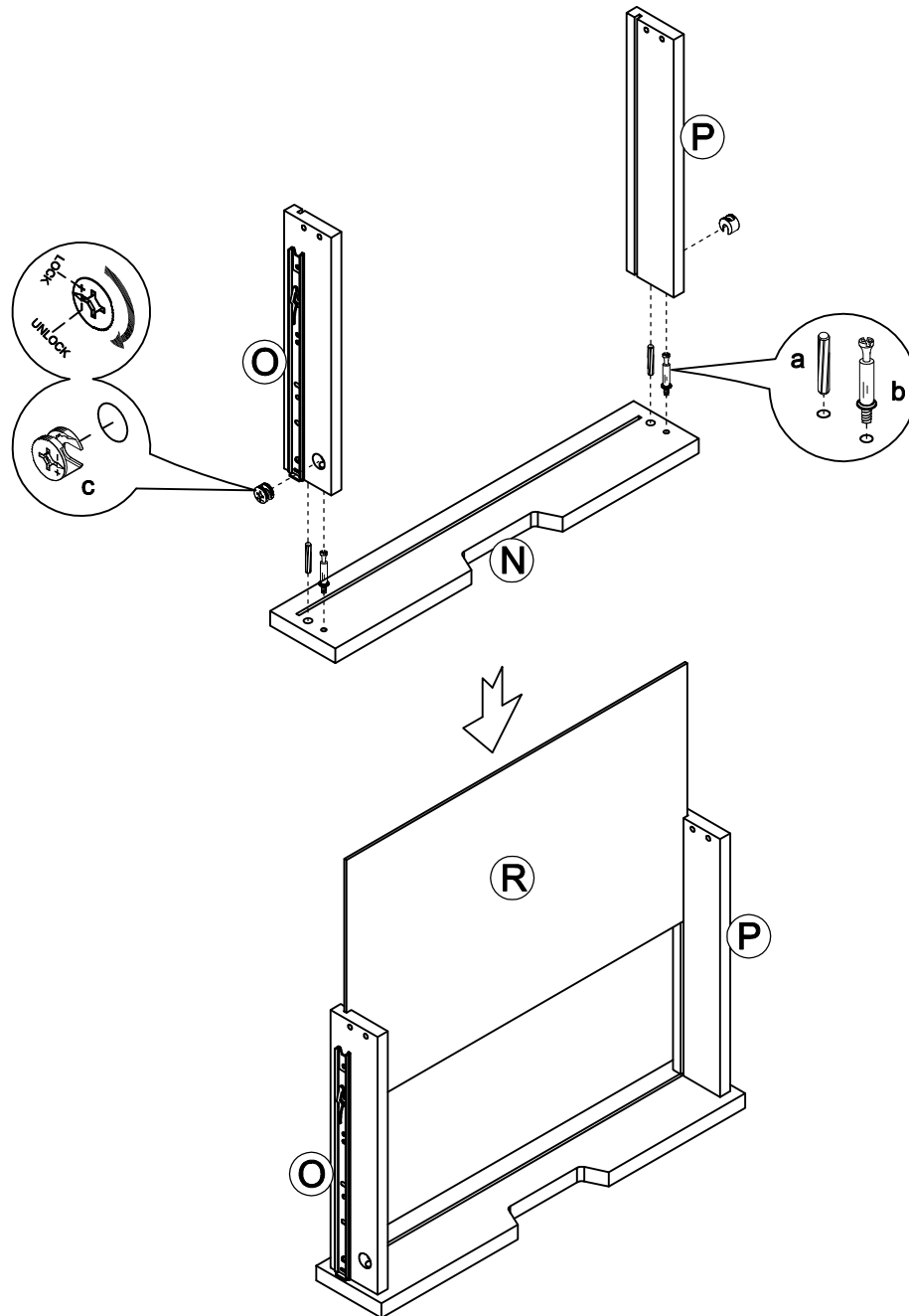
- INSTALL THE WOOD DOWEL (a) AND THE CAM LOCK BOLT (b) INTO THE TOP PANEL (A).
- JOIN THE TOP PANEL (A) TO THE ASSEMBLED PART BY USING WOOD DOWEL (a) FIRST.
- TIGHTEN THE CAM LOCK BOLT (b) WITH THE CAM LOCK (c) FROM PRE-DRILLED HOLES.
- COVER THE CAM HOLES WITH PLASTIC COVER (d).

FIG 9



- ATTACH THE LEFT SIDE DOOR BOX (L) AND THE RIGHT SIDE DOOR BOX (M) TO THE ASSEMBLED PART BY USING THE HINGE (k) AND THE 1/2" FLAT HEAD SCREW (e).
- TIGHTEN THE HANDLE (f) TO THE LEFT SIDE DOOR BOX (L) AND THE RIGHT SIDE DOOR BOX (M) BY USING THE HANDLE BOLT (g).

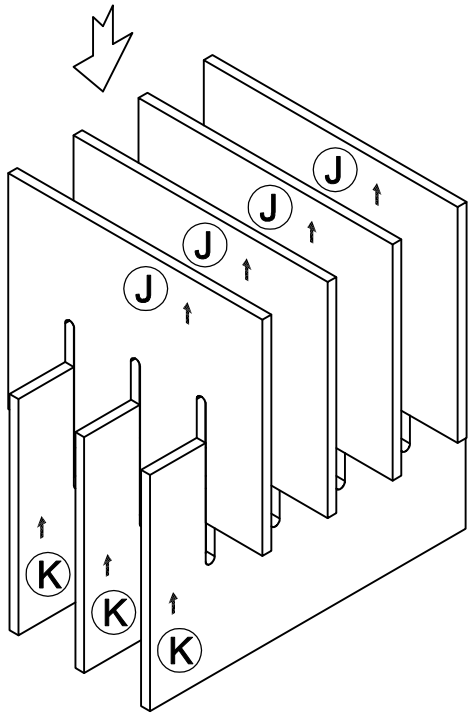
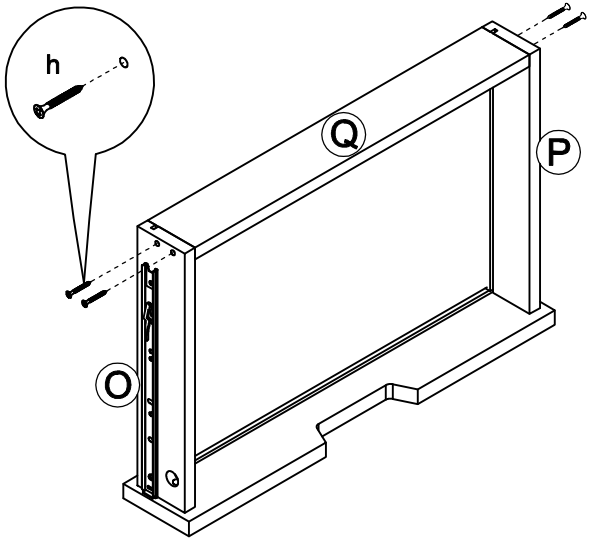
FIG 10



- INSTALL THE WOOD DOWEL (a) AND THE CAM LOCK BOLT (b) INTO THE DRAWER FRONT PANEL (N).
- JOIN THE DRAWER LEFT SIDE PANEL (O) AND THE DRAWER RIGHT SIDE PANEL (P) TO THE DRAWER FRONT PANEL (N).
- ONCE JOINED, TIGHTEN CAM LOCK (c) ONTO THE CAM LOCK BOLT (b) USING PRE-DRILLED HOLES.
- SLIDE THE DRAWER BOTTOM PANEL (R) INTO THE GROOVES ON THE DRAWER LEFT SIDE PANEL (O) AND THE DRAWER RIGHT SIDE PANEL (P).

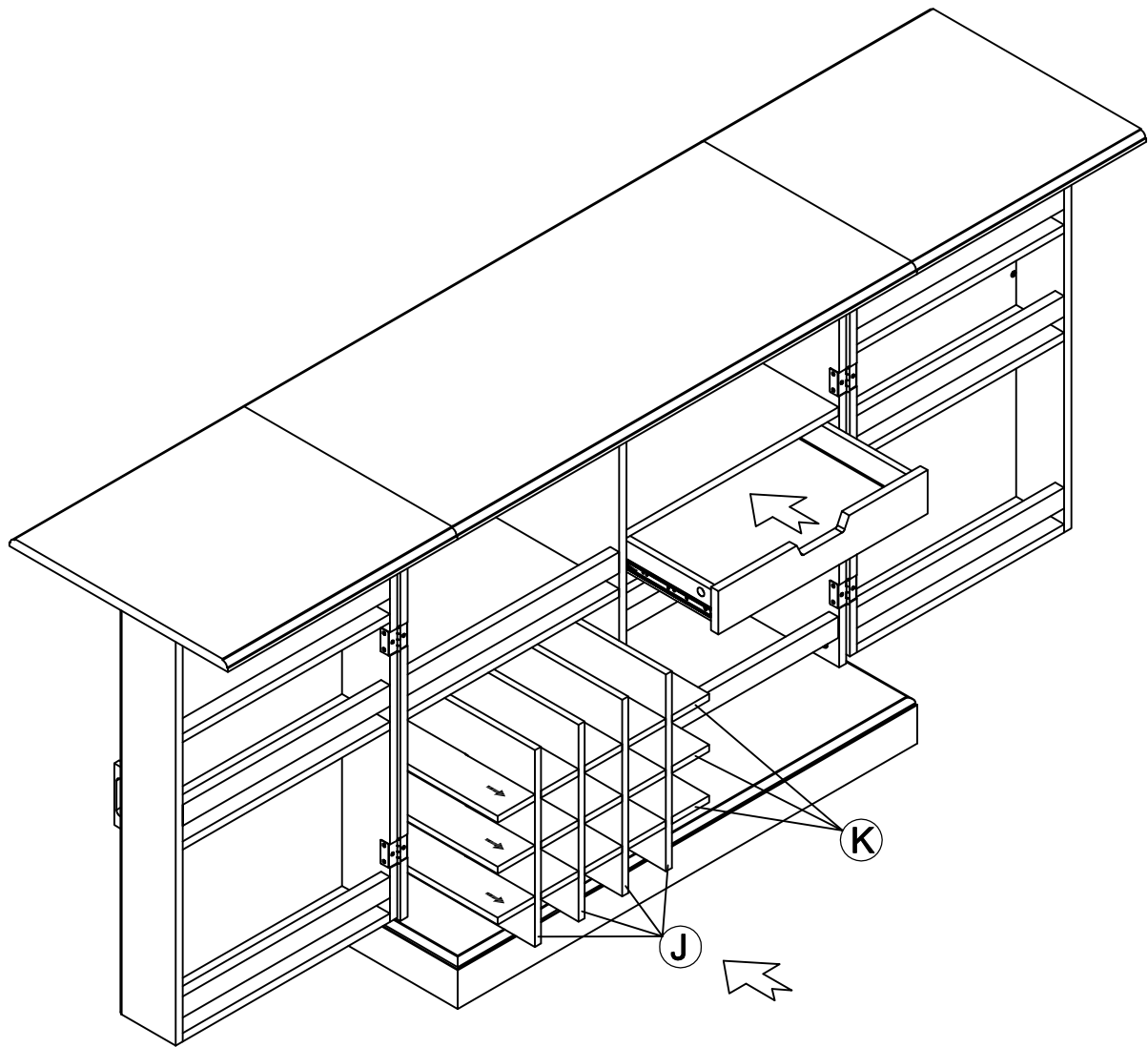


FIG 11



- JOIN THE DRAWER BACK PANEL (Q) TO THE ASSEMBLED DRAWER PART AND TIGHTEN THE DRAWER BACK PANEL (Q) BY USING THE 1" FLAT HEAD SCREW (h) THROUGH PRE-DRILLED HOLES ON DRAWER SIDE PANELS.
- WINE RACK VERTICAL PANEL (J) INSERTED INTO THE WINE RACK LEVEL PANEL (K).

FIG 12



- INSERT THE WINE RACK VERTICAL PANEL (J) AND THE WINE RACK LEVEL PANEL (K) IN THE ASSEMBLED PART.
- INSERT DRAWER INTO THE ASSEMBLED PART.