

Before you start.

BEFORE YOU START

- The water softener requires a minimum water flow of 3 gallons per minute at the inlet. Maximum allowable inlet water pressure is 125 psi. If daytime pressure is over 80 psi, nighttime pressure may exceed the maximum. Use a pressure reducing valve if necessary (Adding a pressure reducing valve may reduce the flow). If your home is equipped with a back flow preventer, an expansion tank must be installed in accordance with local codes and laws.
- The water softener uses a direct plug-in external power supply (included). Be sure to use the included power supply and plug it into a nominal 120V, 60 cycle household outlet that is in a dry location only, grounded and properly protected by an over current device such as a circuit breaker or fuse.
- Do not use this system to treat water that is microbiologically unsafe or of unknown quality without adequate disinfection upstream or downstream of the system.

TOOLS AND MATERIALS REQUIRED FOR INSTALLATION

- Pliers
- Screwdriver
- Teflon tape
- Razor knife
- Two adjustable wrenches
- Additional tools may be required if modification to home plumbing is necessary.

INSPECT SHIPMENT

The parts required to assemble and install the water softener are included with the unit. Thoroughly check the water softener for possible shipping damage and parts loss. Also inspect and note any damage to the shipping carton.

Remove and discard (or recycle) all packing materials. To avoid loss of small parts, we suggest you keep the small parts in the parts bag until you are ready to use them.

! WARNING! Discard all unused parts and packaging material after installation. Small parts remaining after the installation could be a choke hazard.

NOTE: Failure to comply with these installation instructions will void the product warranty, and the installer will be responsible for any service, repair or damages caused thereby.

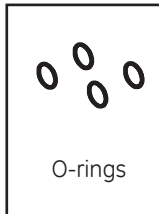
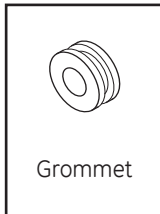
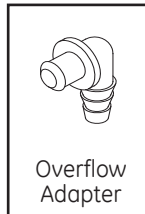
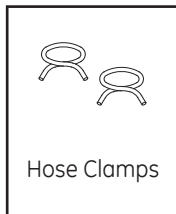
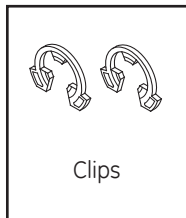
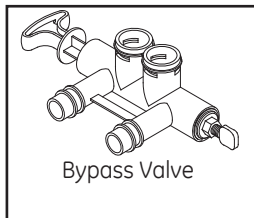
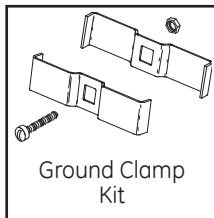

Installation Requirements.

LOCATION REQUIREMENTS

Consider all of the following when selecting an installation location for the water softener.

- Do not locate the water softener where freezing temperatures occur. Do not attempt to treat water over 120°F. **Freezing temperatures or hot water damage voids the warranty.**
- To condition all water in the home, install the water softener close to the water supply inlet, and upstream of all other plumbing connections, except outside water pipes. Outside faucets should remain on hard water to avoid wasting conditioned water and salt.
- A nearby drain is needed to carry away regeneration discharge (drain) water. Use a floor drain, laundry tub, sump, standpipe, or other options (check your local codes). See "Air Gap Requirements" and "Valve Drain Requirements" sections.
- The water softener uses a direct plug-in external power supply (included). Be sure to use the included power supply and plug it into a nominal 120V, 60 cycle household outlet that is in a dry location only, grounded and properly protected by an over current device such as a circuit breaker or fuse.
- Always install the water softener between the water inlet and water heater. Any other installed water conditioning equipment should be installed between the water inlet and water softener (See Figure below).
- If installing the water softener outdoors, do not locate where it will be exposed to wet weather, direct sunlight, extreme hot or cold temperatures, or other forms of abuse.

- DO NOT RUN HOT WATER THROUGH THE SOFTENER.** Temperature of water passing through the softener must be less than 120° F.
- Avoid installing in direct sunlight. Excessive sun heat may cause distortion or other damage to non-metallic parts.
- When installing in an outside location you must take steps necessary to assure the softener, installation plumbing and wiring, are protected from the elements, direct sunlight, contamination, vandalism, insects, vermin, etc.
- Do not install the softener where it would block access to the water heater or access to the main water shutoff.

DIMENSIONS

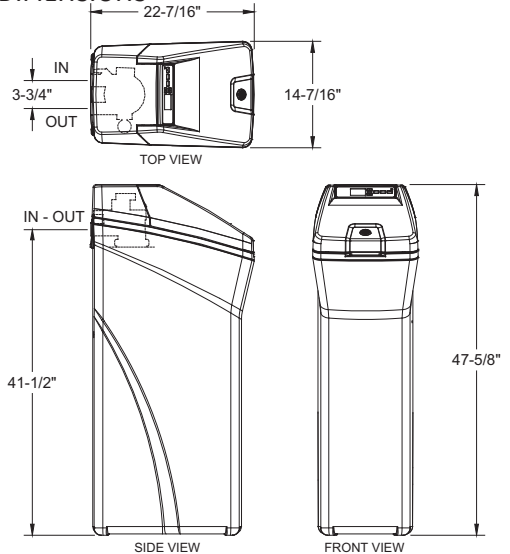

PROPER ORDER TO INSTALL WATER TREATMENT EQUIPMENT

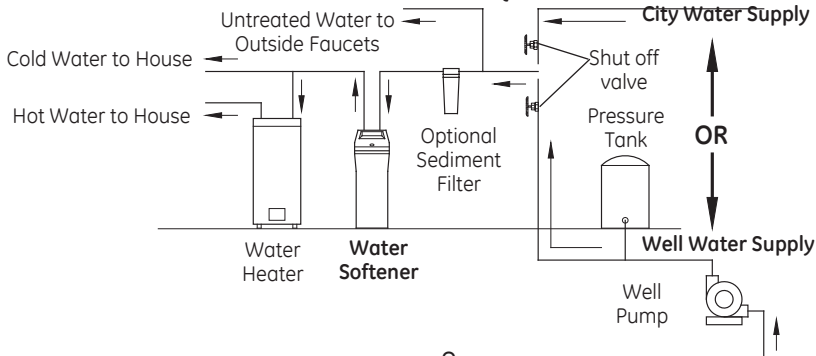

Installation Requirements.

PLUMBING CODES

All plumbing must be completed in accordance with national, state and local plumbing codes.

In the state of Massachusetts: The Commonwealth of Massachusetts plumbing code 248-CMR shall be adhered to. A licensed plumber shall be used for this installation.

AIR GAP REQUIREMENTS

A drain is needed for regeneration water (See Figure 1). A floor drain, close to the water softener, is preferred. A laundry tub, standpipe, etc. are other drain options. Secure valve drain hose in place. Leave an air gap of 1-1/2" between the end of the hose and the drain. This gap is needed to prevent back flow of sewer water into the water softener. Do not put the end of the drain hose into the drain.

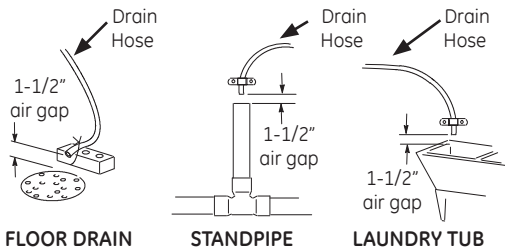

Figure 1

VALVE DRAIN REQUIREMENTS

Using the flexible drain hose (included) (see Figure 2), measure and cut to the length needed. Flexible drain hose is not allowed in all localities (check your plumbing codes). If local codes do not allow use of a flexible drain hose, a rigid valve drain run must be used. Purchase a compression fitting (1/4 NPT x 1/2 in. minimum tube) and 1/2" tubing from your local hardware store. Plumb a rigid drain as needed (See Figure 3).

NOTE: Avoid drain hose runs longer than 30 feet. Avoid elevating the hose more than 8 feet above the floor. Make the valve drain line as short and direct as possible.

FLEXIBLE DRAIN LINE

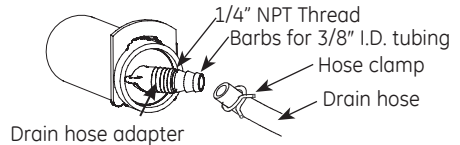

Figure 2

RIGID DRAIN LINE

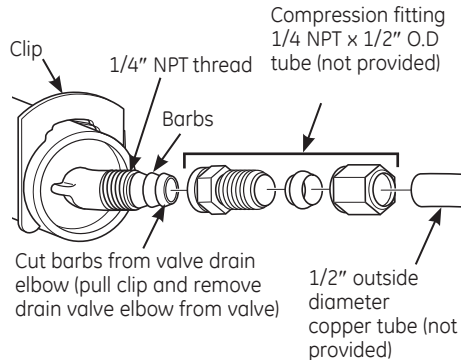

Figure 3

Installation Requirements.

INLET/OUTLET PLUMBING REQUIREMENTS

Always install either a single bypass valve (provided), as shown in Figure 4, or, if desired, parts for a 3 valve bypass system (not included) can be purchased and assembled, as shown in Figure 5. Bypass valves allow you to turn off water to the softener for maintenance if needed, but still have water in house pipes.

Pipe fittings must be 1/2" minimum.

Use:

- Copper pipe
- Threaded pipe
- PEX (Crosslinked Polyethylene) pipe
- CPVC plastic pipe
- Other pipe approved for use with potable water

IMPORTANT: Do not solder with plumbing attached to installation adaptors and single bypass valve. Soldering heat will damage the adaptors and valve.

SINGLE BYPASS VALVE

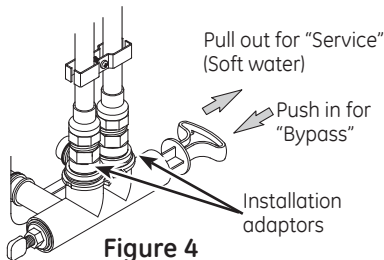

Figure 4

⚠ DANGER:

Electric Shock Hazard:

Install metal ground clamp to metal house water supply pipe before beginning installation. Securely tighten connection in center of metal ground clamp. Failure to do so can result in death or electric shock.

3-VALVE BYPASS SYSTEM

For soft water service: Open the inlet and outlet valves and close the bypass valve.

For bypass hard water: Close the inlet and outlet valves and open the bypass valve.

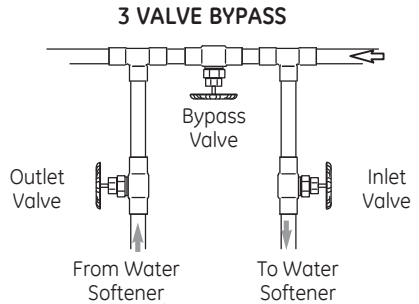

Figure 5

Installation Instructions.

TYPICAL INSTALLATION

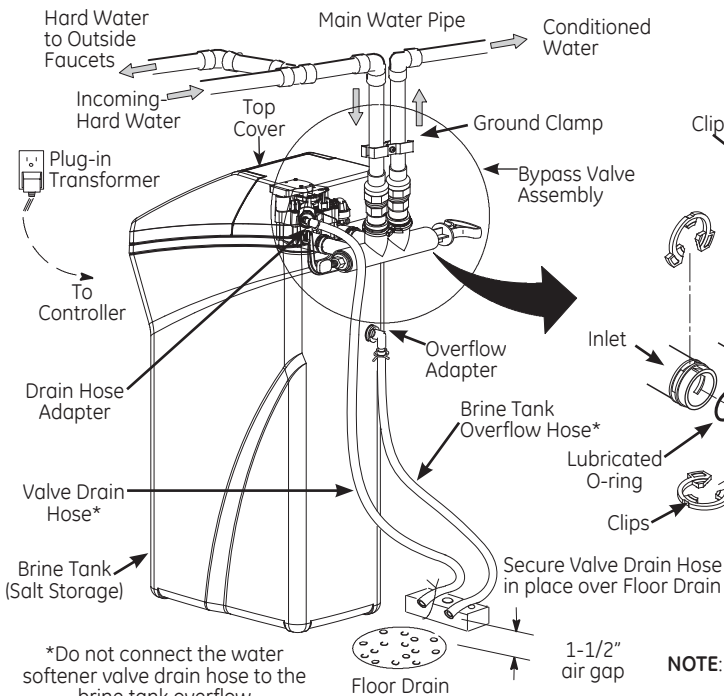

Figure 6

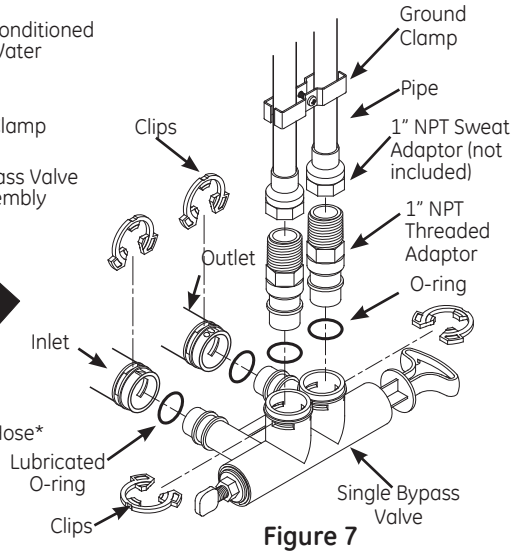

Figure 7

NOTE: See "Air Gap Requirements" section.

- Remove plastic shipping plug and wire from valve outlet.

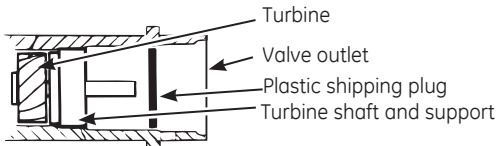

Figure 8

NOTE: Be sure the turbine and support are firmly in place in the valve outlet. Blow into the valve port and observe the turbine for free rotation.

Installation Instructions.

TURN OFF WATER SUPPLY

1. Close the main water supply valve, located near the well pump or water meter.
2. Open all faucets to drain all water from house pipes.

NOTE: Be sure not to drain water from the water heater, as damage to the water heater elements could result.

INSTALL THE BRINE TANK OVERFLOW ADAPTER

Install the brine tank overflow grommet and adapter in the 13/16" diameter hole in the back of the salt storage tank sidewall, (see Figure 9).

NOTE: The brine tank overflow adapter accepts either 1/2" or 3/8" I.D. hose.

INSTALL THE BYPASS VALVE

NOTE: For easier installation, remove the top cover. Release 2 clips at rear of cover. Rotate cover forward and lift up.

1. Remove two clips from the water softener valve inlet and outlet ports and visually check and remove any debris, (see Figure 7).
2. Make sure the turbine assembly spins freely in the "out" port of the valve, see Figure 8.
3. If not already done, put a light coating of silicone grease (provided) on the single bypass valve o-rings, (see Figure 7).
4. Push the single bypass valve into the softener valve as far as it will go. Snap the two large holding clips into place, from the top down, (see Figure 7 and 10).

IMPORTANT: Be sure the clips snap firmly into place so the single bypass valve will not pull out.

MOVE THE WATER SOFTENER INTO PLACE

⚠ WARNING!
Excessive Weight Hazard

Use two or more people to move and install water Softener Failure to do so can result in back or other injury.

1. Move the water softener into the desired location. Set it on a solid, level surface.

IMPORTANT: Do not place shims directly under the salt storage tank to level the softener. The weight of the tank, when full of water and salt, may cause the tank to fracture at the shim.

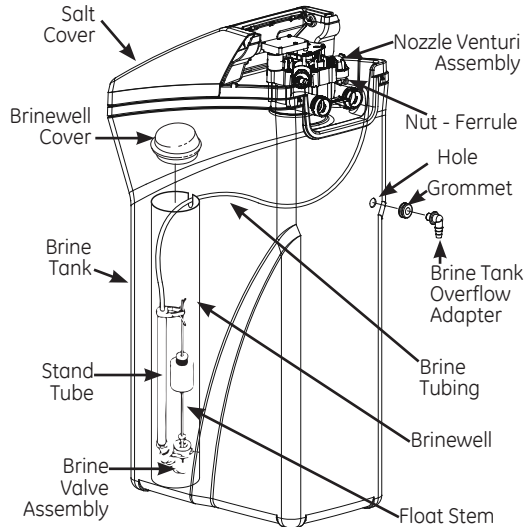
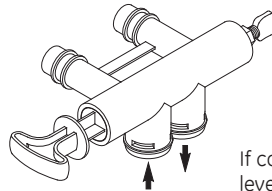

Figure 9

Note: Unit is shown with top cover removed.

SINGLE BYPASS VALVE



If connecting to floor level plumbing, install the bypass valve turned downward, as shown.

CORRECT ASSEMBLY

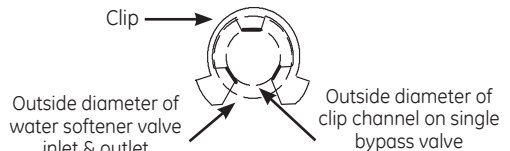

Figure 10

NOTE: Be sure all 3 tabs of the clip go through the matching holes on the water softener valve inlet or outlet, and fully into the channel on the single bypass valve. Make sure that the tabs are fully seated.

Installation Instructions.

COMPLETE INLET AND OUTLET PLUMBING

! WARNING!

ELECTRICAL SHOCK HAZARD: Install metal ground clamp to metal house water supply pipe before beginning installation. Securely tighten connection in center of metal ground clamp. Failure to do so can result in death or electrical shock.

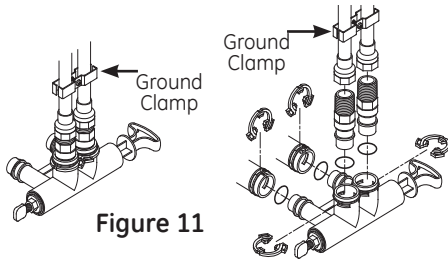

Figure 11

- Secure ground clamp to metal pipes.

Measure, cut, and loosely assemble pipe and fittings from the main water pipe to the inlet and outlet ports of the water softener valve. Be sure to keep fittings fully together, and pipes squared and straight. **BE SURE INCOMING HARD WATER SUPPLY IS DIRECTED TO THE SOFTENER VALVE INLET PORT.**

NOTE: Inlet and outlet are marked on the water softener valve. Trace the water flow direction to be sure hard water is to inlet.

IMPORTANT: Be sure to fit, align and support all plumbing to prevent putting stress on the water softener valve inlet and outlet. Stress from misaligned or unsupported plumbing may cause damage to the valve.

- If making a soldered copper installation, do all sweat soldering before connecting pipes to the NPT adapters and bypass valve. Torch heat will damage plastic parts.

! WARNING!

If solder is used to make pipe connection use only lead free solder and flux to prevent lead poisoning.

- When turning threaded pipe fittings onto plastic fittings, use care not to cross-thread.
- Use Teflon Tape on all external pipe threads.

Complete the inlet and outlet plumbing for the type of pipe you will be using. Secure ground clamp to metal pipes.

Installation Instructions.

INSTALL VALVE DRAIN HOSE

1. Measure and connect the 3/8" drain line (provided) to the water softener valve drain fitting. Use a hose clamp to hold the hose in place.

NOTE: Avoid drain hose runs longer than 30 feet. Avoid elevating the hose more than 8 feet above the floor. Make the valve drain line as short and direct as possible.

IMPORTANT: If codes require a rigid drain line see "Valve Drain requirements" section.

2. Route the drain hose or copper tubing to the floor drain or other suitable drain point. Secure drain hose. This will prevent "whipping" during regenerations. See "Air Gap Requirements" section (Figure 1).
3. Cut and secure the hose.

NOTE: The softener will not work if the water cannot exit the drain hose during recharge.

INSTALL BRINE TANK (SALT STORAGE) OVERFLOW HOSE

1. Measure, cut to needed length and connect the 3/8" drain line (provided) to the salt storage tank overflow elbow and secure in place with a hose clamp.
2. Route the hose to the floor drain, or other suitable drain point **no higher** than the drain fitting on the salt storage tank (This is a gravity drain). If the tank overfills with water, the excess water flows to the drain point. Cut the drain line to the desired length and route it neatly out of the way.

IMPORTANT: For proper operation of the water softener, do not connect the water softener valve drain tubing to the salt storage tank overflow hose.

TEST FOR LEAKS

To prevent air pressure in the water softener and plumbing system, complete the following steps in order:

1. Fully open two or more softened cold water faucets close to the water softener, located down stream from the water softener.
2. Place the bypass valve (single or 3 valve) into the "bypass" position (see Figures on Page 10).
3. Slowly open the main water supply valve. Run water until there is a steady flow from the opened faucets, with no air bubbles.
4. Place bypass valve(s) in "service" or soft water position as follows:
 - Single bypass valve (Figure 4): Slowly move the valve stem toward "service," pausing several times to allow the water softener to fill with water.
 - 3 valve bypass (Figure 5): Fully close the bypass valve and open the outlet valve. Slowly open the inlet valve, pausing several times to allow the water softener to fill with water.
5. After about three minutes, open a hot water faucet until there is a steady flow and there are no air bubbles, then close this faucet.
6. Close all cold water faucets and check for leaks at the plumbing connections that you made.
7. Check for leaks around clips at softener's inlet and outlet. If a leak occurs at a clip, depressurize the plumbing (turn off the water supply and open faucets) before removing clip. When removing clips at the softener's inlet or outlet, push the single bypass valve body toward the softener (See Figure 14). Improper removal may damage clips. Do not reinstall damaged clips.

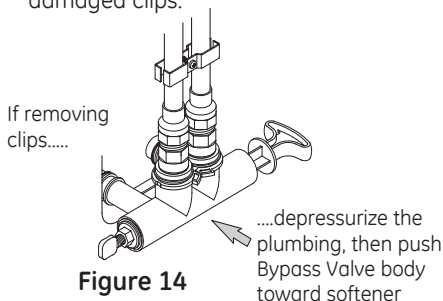

Figure 14

Installation Instructions.

ADD WATER AND SALT TO THE SALT STORAGE TANK

WARNING!

EXCESSIVE WEIGHT HAZARD:
Use two or more people to move and lift salt bags. Failure to do so can result in back or other injuries.

1. Using a container, add about three gallons of clean water into the salt storage tank.
2. Add salt to the storage tank. Use nugget, pellet or coarse solar salts with less than 1% impurities.

PLUG IN THE WATER SOFTENER

1. Plug the water softener into an electrical outlet that is not controlled by a switch.
2. Replace the top cover.
3. Replace the salt hole cover.

NOTE: The water heater is filled with hard water and, as hot water is used, it will refill with conditioned water. In a few days, the hot water will be fully conditioned. To have fully conditioned hot water immediately, wait until the initial recharge is over. Then, drain the water heater (following instructions for water heater) until water runs cold.

 **WARNING!** *Discard all unused parts and packaging material after installation. Small parts remaining after the installation could be a choke hazard.*

SANITIZE THE WATER SOFTENER /SANITIZE AFTER SERVICE

1. Open salt hole cover, remove the brinewell cover and pour about 3 oz. (6 tablespoons) of household bleach into the softener brinewell. Replace the brinewell cover.
2. Make sure the bypass valve(s) is in the "service"(open) position.
3. Start a recharge (regeneration). See "Start a Recharge" on Page 18.
4. After the recharge has completed, fully open a cold water faucet, downstream from the softener, and allow 50 gallons of water to pass through the system. This should take at least 20 minutes. Close the faucet.

Exploded View.

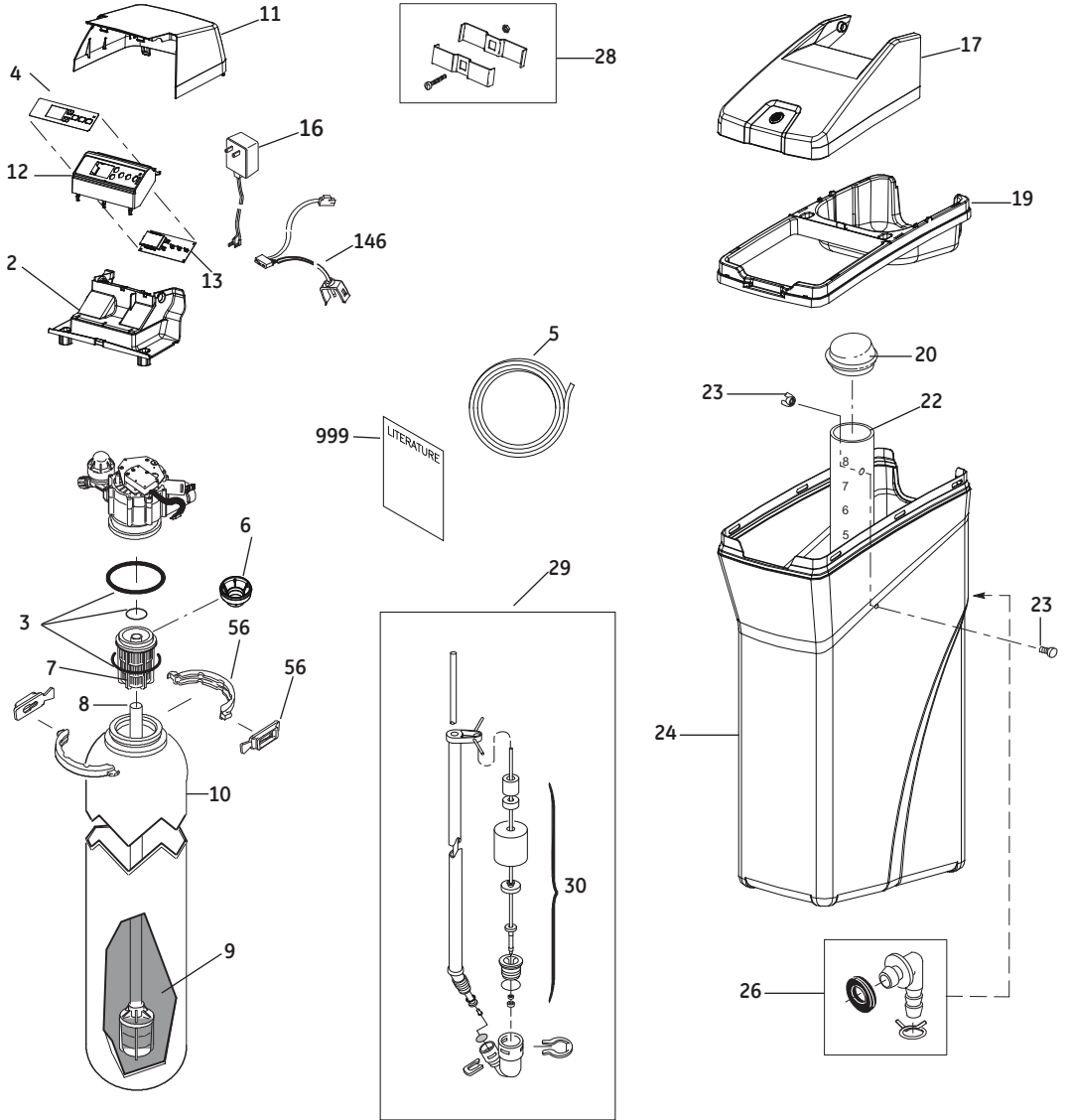

Exploded View.

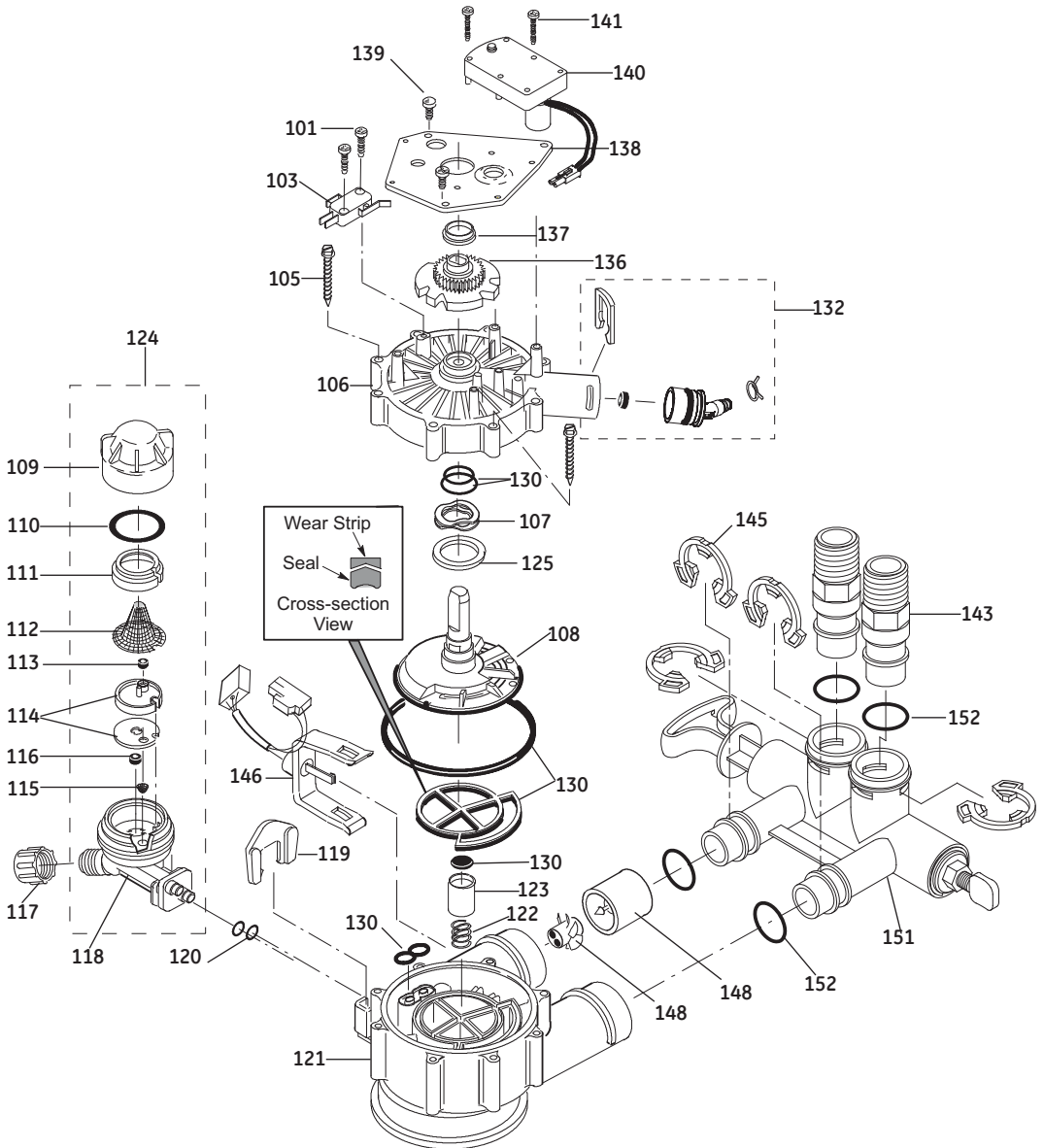

Parts List.

REF. NO.	GE PART NO.	PART DESCRIPTION	(00)	(00)
			G	G
			X	X
			S	S
			H	H
			4	4
			0	5
			V	V
0002	WS31X10051	BACK COVER, ELECTRONICS	1	1
0003	WS35X10001	O-RING SEAL KIT	1	1
0004	WS34X10023	DECAL, FACEPLATE	1	1
0005	WS07X10004	HOSE, DRAIN, 20 FT.	1	1
0006	WS31X10044	FILTER SCREEN	1	1
0007	WS14X10002	DISTRIBUTOR, TOP	1	1
0008	WS14X10005	DISTRIBUTOR, BOTTOM	1	1
0009	WS01X10002	RESIN, 1-CU. FT.	1	1
0010	WS32X10011	TANK, RESIN 9X40	1	
0010	WS32X10018	TANK, RESIN 10X40		1
0011	WS31X10052	COVER, TOP	1	1
0012	WS34X10021	FACEPLATE	1	1
0013	WS21X10054	CONTROL	1	1
0016	WS26X10013	EXTERNAL POWER SUPPLY WITH POWER CORD	1	1
0017	WS31X10053	COVER, SALT HOLE, WITH LABELS	1	1
0019	WS33X10010	RIM	1	1
0020	WS31X10024	COVER, BRINEWELL	1	1
0022	WS34X10025	BRINEWELL	1	1
0023	WS02X10088	SCREW KIT, BRINE TANK	1	1
0024	WS32X10032	TANK, BRINE	1	1
0026	WS22X10063	OVERFLOW ADAPTER KIT	1	1
0028	WS35X10035	GROUND CLAMP KIT	1	1
0029	WS15X10077	BRINE VALVE ASM.	1	1
0030	WS35X10063	FLOAT, STEM & GUIDE	1	1
0056	WS28X10078	TANK NECK CLAMP KIT	1	1
0101	WS02X10023	SCREW. #4 - 24 X 3/4"	2	2
0103	WS21X10003	SWITCH	1	1
0105	WS02X10024	SCREW. #10 X 2 5/8"	8	8
0106	WS31X10013	COVER, VALVE	1	1
0107	WS03X10034	WASHER WAVE	1	1
0108	WS26X10010	ROTOR & DISC ASM.	1	1
0109	WS19X10010	CAP	1	1
0110	WS03X10011	SEAL, O-RING 1.125 X 1.37	1	1

Parts List.

REF. NO.	GE PART NO.	PART DESCRIPTION	(00)	(00)
			G	G
			X	X
			S	S
			H	H
			4	4
			0	5
			V	V
0111	WS19X10005	SUPPORT SCREEN	1	1
0112	WS03X10013	SCREEN	1	1
0113	WS22X10036	FLOW PLUG, .15 GPM	1	1
0114	WS08X10008	GASKET, NOZZLE/VENT	1	1
0115	WS03X10073	CONE SCREEN	1	1
0116	WS22X10021	PLUG, FILL FLOW .30 GPM	1	1
0117	WS03X10017	NUT FERRULE	1	1
0118	WS15X10034	NOZZLE/VENTURI BODY	1	1
0119	WS03X10018	RETAINER	1	1
0120	WS03X10019	SEAL, O-RING 1/4" X 3/8"	2	2
0121	WS15X10025	BODY, VALVE	1	1
0122	WS03X10020	SPRING	1	1
0123	WS22X10029	PLUG, DRAIN SEAL	1	1
0124	WS15X10046	NOZZLE/VENTURI ASM.	1	1
0125	WS03X10043	WAVE SPRING BEARING	1	1
0130	WS35X10020	SEAL KIT	1	1
0132	WS22X10065	DRAIN HOSE ADAPTER KIT	1	1
0136	WS26X10008	CAM & GEAR	1	1
0137	WS26X10009	BEARING	1	1
0138	WS26X10023	PLATE, MOTOR	1	1
0139	WS02X10028	SCREW, #6-20 X 3/8"	3	3
0140	WS26X10021	MOTOR ASM.	1	1
0141	WS02X10058	SCREW, #8-32 X 1"	2	2
0143	WS60X10011	ADAPTER-NPT THREAD-1" VALVE	2	2
0145	WS60X10008	CLIP	4	4
0146	WS28X10018	HARNES WIRE, SENSOR ASSY	1	1
0148	WS26X10030	TURBINE & SUPPORT ASSEMBLY*	1	1
0151	WS15X10078	BYPASS ASM.	1	1
0152	WS03X10072	SEAL, O-RING	4	4
0998	WS35X10065	INSTALLATION KIT	1	1
0999	49-50283-2	OWNER'S MANUAL	1	1

* Includes 2 each of REF. NO. 145 (CLIP) & REF. NO. 152 (O-RING)