

ALC™

SIGHT HD

Remote Monitoring Anytime from Anywhere

Wireless Made Simple.

720p Indoor Wi-Fi Camera



Model AWF11

User Guide

Please read these instructions completely
before operating this product.

IMPORTANT SAFETY INSTRUCTIONS 2

INTRODUCTION 5

 System Contents 5

 Getting to Know Your Camera 6

INSTALLATION 7

 Installation Tips 7

 Night Vision 7

 Installing the Camera 8

REMOTE ACCESS 10

 Overview 10

 Requirements for Remote View 10

 Connecting to the Internet 11

 Connecting Via the Android App 12

 Connecting Via the Apple App 14

 ALC SightHD App Icons 19

 To Take Snapshots 22

 To View and/or Take Videos 24

 Motion Recordings 25

 Camera Speaker Functions 25

 To Play Videos 26

 To Delete Recordings 29

 Information Screen Options 31

 DID Setting Screen 35

 Advanced Settings 37

MAINTENANCE 41

TROUBLESHOOTING 42

FACTORY DEFAULT/RESET 43

UPGRADING THE FIRMWARE 43

PRODUCT SPECIFICATIONS 44

WARRANTY 45

PRODUCT SAFETY: When used in the directed manner, this unit has been designed and manufactured to ensure your personal safety. Improper use of this product can result in potential electrical shock or fire hazards. Please read all safety and operating instructions carefully before installation and use, and keep these instructions handy for future reference.

CAUTION
RISK OF ELECTRIC SHOCK
DO NOT OPEN

CAUTION: To reduce the risk of electric shock do not remove cover (or back). No user serviceable parts inside. Refer servicing to qualified service personnel.



DANGEROUS VOLTAGE: The lightning flash with arrowhead, within an equilateral triangle, is intended to alert the user to the presence of uninsulated dangerous voltage within the product's enclosure that may be of sufficient magnitude to constitute a risk of electric shock to persons.



ATTENTION: The exclamation point within an equilateral triangle is intended to alert the user to the presence of important operating and maintenance (servicing) instructions in the literature accompanying the appliance.

WARNING: TO PREVENT FIRE OR SHOCK HAZARD, DO NOT EXPOSE THIS UNIT TO RAIN OR MOISTURE.



Products with CE Marking comply with EMC Directive (2004/108/EC); Low Voltage Directive (73/23/EEC); R&TTE(1999/5/EC); ROHS Directive (2011/65/EU) issued by the Commission of the European Community. Compliance with these directives implies conformity to the following European Norms:

EMC: EN 301 489 LVD: EN 60950 Radio: EN 300 328



FCC Compliance Statement: This device complies with Part 15 of the FCC rules. Operation is subjected to the following two conditions: (1) this device may not cause harmful interference, and (2) this device must accept any interference received, including interference that may cause undesired operation.

FCC/CE WARNING

This equipment has been tested and found to comply with limits for a Class B digital device, pursuant to Part 15 of the FCC rules and ETS(EN) 300328. These limits are designed to provide reasonable protection against harmful interference in residential installations. This equipment generates, uses, and can radiate radio frequency energy, and if not installed and used in accordance with the instructions, may cause harmful interference to radio communications. However, there is no guarantee that interference will not occur in a particular installation. If this equipment does cause interference to radio or television equipment reception, which can be determined by turning the equipment off and on, the user is encouraged to try to correct the interference by one or more of the following measures:

- Reorient or relocate the receiving Antenna.
- Move the equipment away from the receiver.
- Plug the equipment into an outlet on a circuit different from that to which the receiver is connected.
- Consult the dealer or an experienced radio/television technician for additional suggestions.

CAUTION: Any changes or modifications to this equipment not expressly approved by the party responsible for compliance could void your authority to operate the equipment.

WARNING:

STRANGULATION HAZARD: Infants have STRANGLED in power cords. Keep power cords more than 3 feet away from cribs, bassinets, play yards, and other safe sleep environments for infants.

IMPORTANT SERVICE SAFETY INSTRUCTIONS

Damages caused by non-compliance with this operating manual will void the warranty!

1. Read and Follow Instructions - All the safety and operating instructions should be read before the product is operated. Follow all operating instructions.
2. Retain Instructions - The safety and operating instructions should be retained for future reference.
3. Heed Warnings - Comply with all warnings on the product and in the operating instructions.
4. Power Sources - This product should be operated only from the type of power source indicated on the marking label. If you are not sure of the type of power supplied to your location, consult your video dealer or local power company. For products intended to operate from battery power, or other sources, refer to the operating instructions.
5. Overloading - Do not overload wall outlets or extension cords as this can result in the risk of fire or electric shock. Overloaded AC outlets, extension cords, frayed power cords, damaged or cracked wire insulation, and broken plugs are dangerous. They may result in a shock or fire hazard. Periodically examine the cord, and if its appearance indicates damage or deteriorated insulation, have it replaced by your service technician.
6. Power-Cord Protection - Power supply cords should be routed so that they are not likely to be walked on or pinched by items placed upon or against them. Pay particular attention to cords at plugs, convenience receptacles, and the point where they exit from the product.
7. Surge Protectors - It is highly recommended that the video equipment be connected to a surge protector. Doing so will protect the equipment from damage caused by power surges. Surge protectors should bear the UL listing mark or CSA certification mark.
8. Uninterruptible Power Supplies (UPS) - Because this product is designed for continuous, 24/7 operation, it is recommended that you connect the product to an uninterruptible power supply. An uninterruptible power supply has an internal battery that will keep the product running in the event of a power outage. Uninterruptible power supplies should bear the UL listing mark or CSA certification mark.

CAUTION: Maintain electrical safety. Power line operated equipment or accessories connected to this product should bear the UL listing mark or CSA certification mark on the accessory itself and should not be modified so as to defeat the safety features. This will help avoid any potential hazard from electrical shock or fire. If in doubt, contact qualified service personnel.

9. Ventilation - Slots and openings in the case are provided for ventilation to ensure reliable operation of the product and to protect it from overheating. These openings must not be blocked or covered. The openings should never be blocked by placing the video equipment on a bed, sofa, rug, or other similar surface. This product should never be placed near or over a radiator or heat register. This product should not be placed in a built-in installation such as a bookcase or rack unless proper ventilation is provided and the product manufacturer's instructions have been followed.

10. Attachments - Do not use attachments unless recommended by the product manufacturer as they may cause a hazard.
11. Water and Moisture - Do not use cameras near water — for example, near a bath tub, wash bowl, kitchen sink or laundry tub, in a wet basement, near a swimming pool and the like.
12. Heat - The camera should be situated away from heat sources such as radiators, heat registers, stoves, or other products (including amplifiers) that produce heat.
13. Accessories - Do not place this camera on an unstable cart, stand, tripod, or table. The camera may fall, causing serious damage to the product. Use this camera only with a cart, stand, tripod, bracket, or table recommended by the manufacturer or sold with the product. Any mounting of the product should follow the manufacturer's instructions and use a mounting accessory recommended by the manufacturer.
14. Camera Extension Cables - Check the rating of your extension cable(s) to verify compliance with your local authority regulations prior to installation.
15. Mounting - The camera provided should be mounted only as instructed in this guide using the provided mounting bracket.
16. Camera Installation - Camera is not intended for outdoor installation. Not all cameras can be installed outdoors. Check your camera's environmental rating to confirm if it can be installed outdoors.

System Contents

After unpacking, you will have the following items:

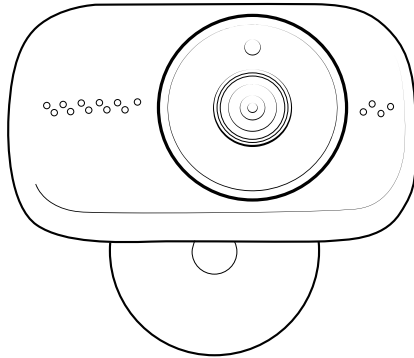

Camera

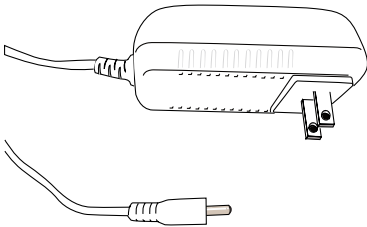

AC Adapter

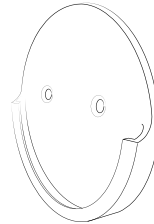

Camera Bracket

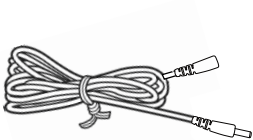

Extension Cable

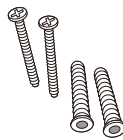

Screw/Anchor Kit



Quick Start Guide

Getting to Know Your Camera

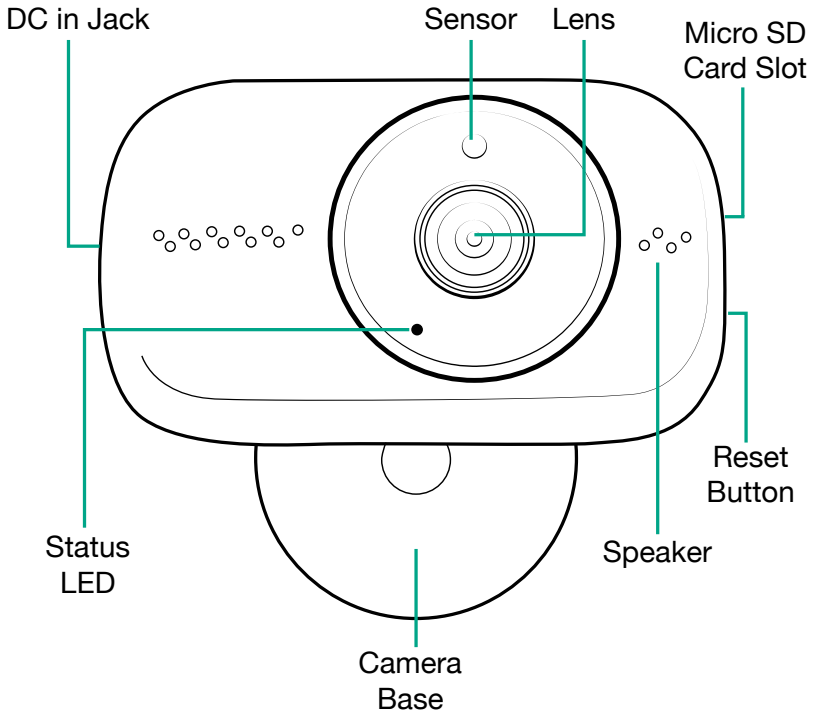

Installation Tips

WARNING:

It is not recommended to use this camera outdoors.

- Before you install the camera, plan where and how it will be positioned, and where you will route the cable that connects the camera to the power adapter.
- Optimized motion detection range is 6 to 18 feet for camera. The farther away an object is, the less accurate the motion detection.
- Avoid having a direct light source in the view of the camera, including street lights, ceiling or floor lamps, spotlights in the driveway, etc.
- Rainfall, pool water ripples/reflections, tree/shrub leaves blowing in the wind – and the shadows they create – can generate motion detection false alarms.
- Before starting permanent installation, have another person check the camera image on the tablet/phone when camera is positioned in the same place it will be permanently installed.
- It is recommended to ensure a clear line of sight between the camera and Wi-Fi router and to limit the amount of obstructions, such as walls and tree branches, between the camera and Wi-Fi router. Walls made of heavy building materials such as brick or concrete will significantly reduce signal range.
- If the signal will have to pass through a wall, placing the Wi-Fi router or camera next to a window will improve the signal strength.
- Do not install the camera pointing out of a window. The night-time picture will be unusable due to reflection from the night vision LEDs.
- As dust, grime, and cobwebs accumulate on the camera glass, they can reflect light from the infrared LED and might lower video quality. Periodically clean the lens glass with a soft cloth.

Night Vision

The camera has built-in infrared LEDs to allow you to view at night for 24-hour surveillance. The LEDs will automatically activate at night and the picture viewed will turn to black and white. The night viewing range is up to 15 feet.

Installing the Camera

- 1 If not mounting, but just using on a flat surface (desk, table, etc.), skip to step 3. Secure the multi-position Camera Bracket to a stable surface, ceiling or wall using the two screws. If needed, two anchors are also included.

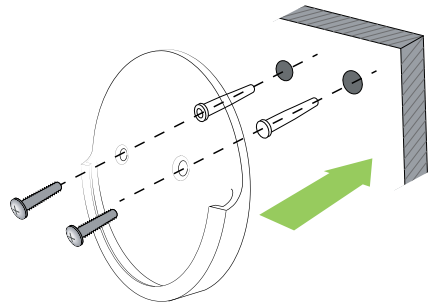

- 2 Slide the camera into the Camera Bracket. Rotate the camera to the desired viewing angle.

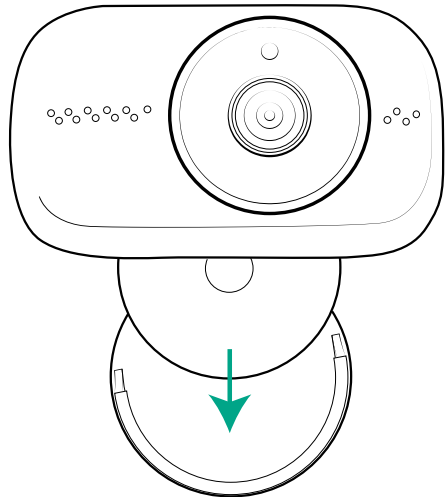

Installing the Camera

- 3 Connect the small end of the AC adapter to the camera's DC IN Jack.

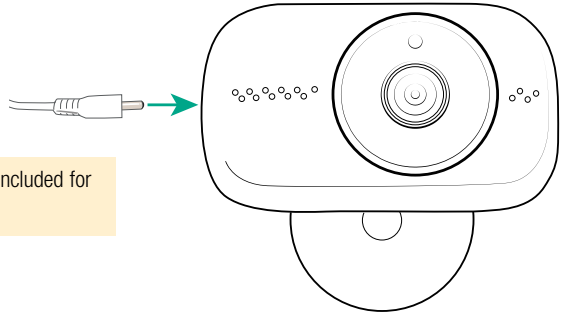

TIP: A 6 foot power extension cable is included for your camera setup if needed.

- 4 Insert an SD Card (up to 32GB-Not included) into the SD Card Slot. This will allow you to record videos.

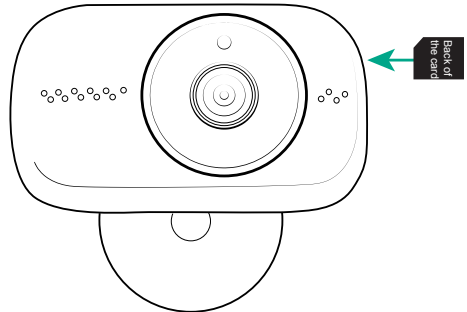

- 5 Plug the other end of the adapter to a 120 volt AC (standard indoor) power outlet. After 30-60 seconds, the red Power Status LED will repeatedly blink three times rapidly.

The camera is now ready to be set up on an Android or Apple device as shown in pages 11 or 14.

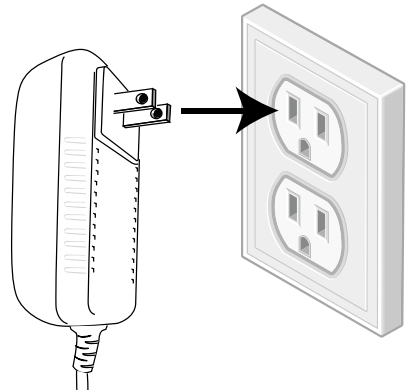

Overview

This camera allows you to view live video from an iPhone®, iPad®, iPod Touch® or Android™ smartphone or tablet. Free apps are available through the Apple App Store or Android Market/Google Play.

Up to three remote users can access live video at the same time as long as they have the User ID (DID) Code and Security Code.

IMPORTANT:

The number of remote viewers is determined by the amount of “available upload bandwidth” on your home network.

Requirements for Remote View

- iPhone®, iPad®, iPod Touch® (iOS 6.0 and above)
- Android™ smartphone or tablet (version 2.3X or above)

IMPORTANT:

Not suitable for Windows mobile devices or Blackberry smartphones.

Recommended Minimum Internet Upload Speed

512Kbps upload speed (or bandwidth) to achieve up to an average of 2FPS viewing speed. Average viewing speed will depend on other restrictions by your ISP (internet service provider).

SCREEN-SHOT NOTE:

The illustrations of the App in this manual are of the Android. The Apple device's App will look very similar and the operation will be the same, except where noted.

Connecting to the Internet

- 1 Download the ALC SightHD App as follows:

APPLE DEVICE:

From your iPhone or iPad, go to the App Store and search for ALC SightHD.

ANDROID DEVICE:

From your Android smartphone or tablet device, go to Google Play and search for ALC SightHD.



2 TO CONNECT VIA WI-FI:

For Apple, go to page 14.

For Android, go to the next page.



Connecting Via the Android App

- 1 Plug camera into an electrical outlet and let the camera go through the start-up process (allow the camera up to 90 seconds to boot up). When the green Power indicator lights, the camera is ready to be set up.

Launch the ALC SightHD App and the Setup Wizard screen will appear.

Tap “+” to start the Wizard.



- 2 Tap **Next**.

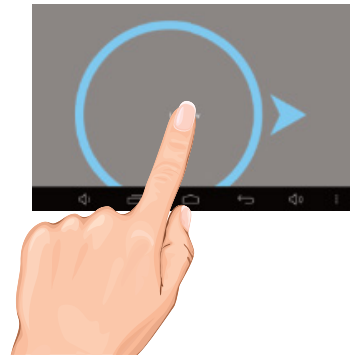

- 3 The App will start the connection process. Tap **Live View**.

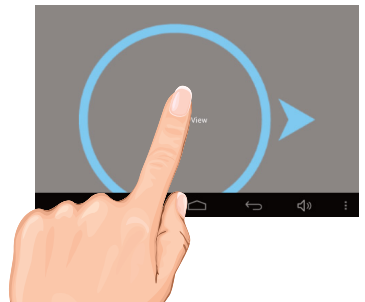



Connecting Via the Android App

4 You will then be requested to change your password if this is the first time accessing the camera. Enter a password and remember it or write it down for future use. Tap **OK**.

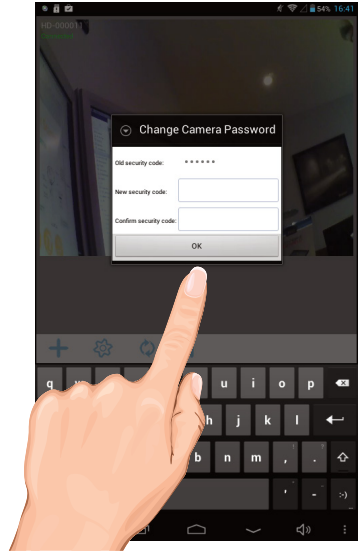

5 The Setup Wi-Fi Network pop up box will appear. Select your home network from the pull down menu, and then enter your home network's Wireless Password. Tap **OK**.

The system will reboot the camera. Please give it up to 90 seconds, until the green Status LED lights solid in the camera. You will then have live video.

If the camera does not connect, tap **Reconnect**.

Go to page 19 for details on the icons and operation.





Connecting Via the Apple App

- 1 Plug camera into an electrical outlet (allow the camera up to 90 seconds to boot up). When the red Link Status indicator begins blinking, the camera is ready to be set up.

Next, on your Apple device, open the Settings App.

IMPORTANT:
The screens in steps 1 and 2 appear when you slide to the next screen.

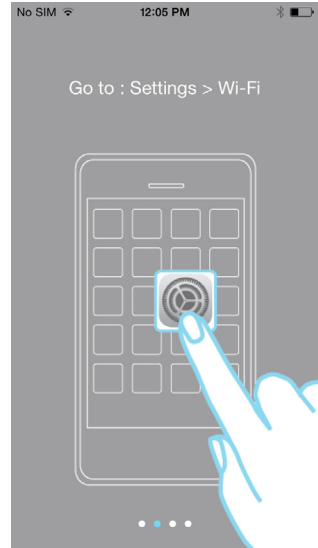

- 2 Tap **Wi-Fi**, and under **Choose A Network**, select the HD-XXXXX Network.

IMPORTANT:
Make sure to set the **Ask To Join Networks** option to on.

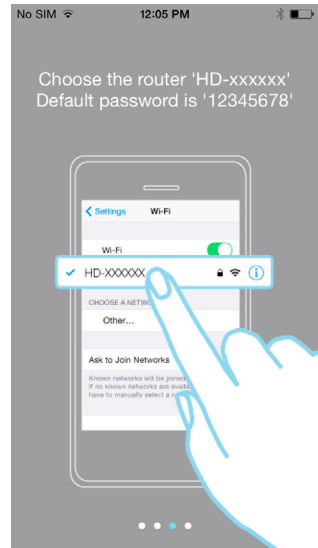

Connecting Via the Apple App



- 3 When asked for a password, enter, "12345678". Tap **Join** to connect.

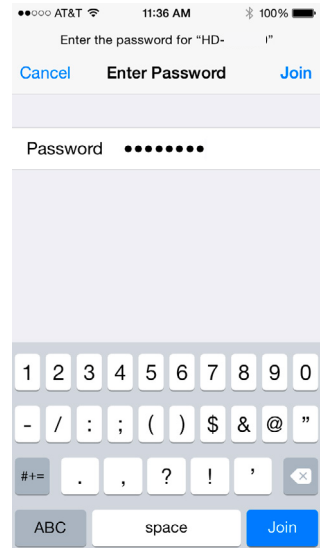

- 4 Now Launch the ALC SightHD App and the Setup Wizard screen will appear indicating the setup instructions. Tap "+" to start the Wizard.





Connecting Via the Apple App

- 5 The Apple Device will now search for the camera.

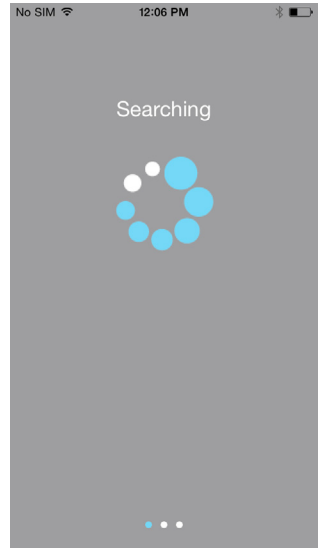

- 6 Once the screen indicates the camera is connected, Tap **Live View**.

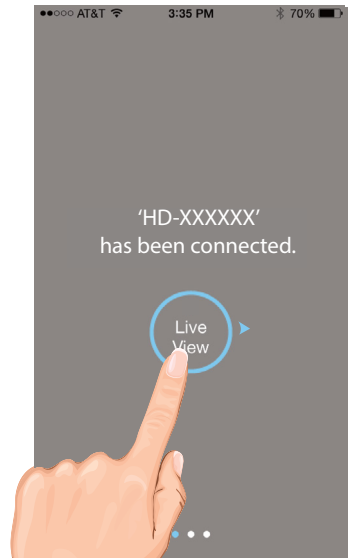



Connecting Via the Apple App

7 The Apple device will scan and detect the camera. Once found, the screen will show a Live View briefly before moving to a set up screen.

You will then be requested to change your password if this is the first time accessing the camera. Enter a password and remember it or write it down for future use. Tap **Wi-Fi Setting**.

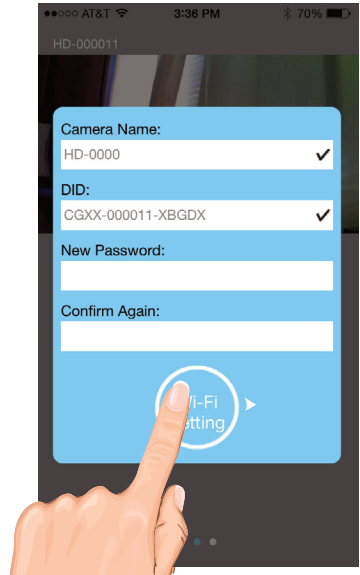

8 The Wi-Fi Network screen will appear. Select your home network from the menu, and then enter your home network's Wireless Password. Tap **OK**.





Connecting Via the Apple App

9 The system will reboot the camera. The reboot will be complete when the App finishes counting down from 90. Tap still picture for live video.

If the camera does not connect, tap **Reconnect** icon.

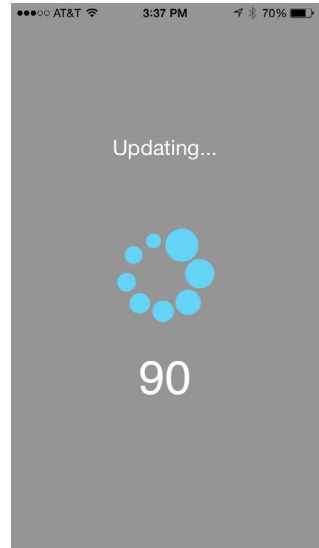

ALC SightHD App Icons

Main Screen

The following icons appear when on the Main screen. Tap the arrows to access the live video screen. If you have already selected a view and go back to the previous screen (arrows screen) a still picture of the live video appears instead. To access the video again, simply tap on the still picture and it will show the live video screen again.

See page 20 for icon descriptions.

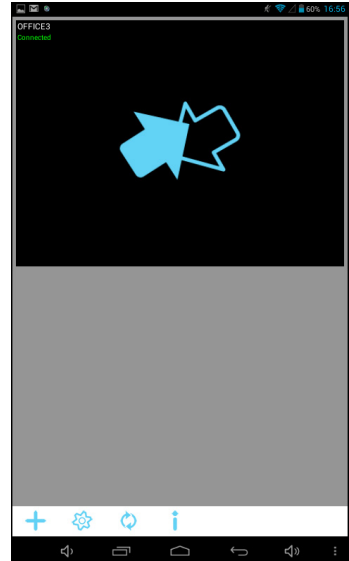





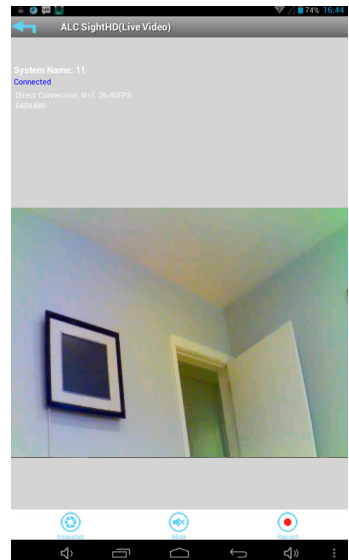

Live View Screen





The following icons appear when on the Live View Screen. See page 20 for icon descriptions.



ALC SightHD App Icons

Icon	Icon Description
<p>Add System</p> 	<p>Tap this icon to enter the setup wizard; see page 12 for Android and page 14 for Apple.</p>
<p>Camera Setting</p> 	<p>Tap this icon to access the App's options. See below:</p> <ul style="list-style-type: none"> <li data-bbox="415 611 975 707">  Tap this icon to set up camera configuration or make changes to your existing settings. It is also where the Advanced Settings are accessed. <li data-bbox="415 724 941 820">  Tap this icon to remove the camera's connection. <li data-bbox="415 858 1016 954">  Tap this icon to access the Events List to check or play back the videos. See page 26.
<p>Refresh</p> 	<p>Tap this icon to refresh the camera's connection.</p>
<p>Information</p> 	<p>Tap this icon to enter the Setup PIN Lock, Set the Notify Setting or check the APP/API version information. See page 31.</p>

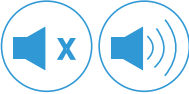
ALC SightHD App Icons

Icon	Icon Description
<p>Capture</p> 	<p>Tap to capture screen images. The snapshots will be saved into the camera roll of your mobile device. See page 22 for more details.</p>
<p>Record</p> 	<p>Tap to record. See page 24 for more details.</p>
<p>Mute</p> 	<p>Press to hear the sound of the camera's microphone through the SightHD App. Tap again to mute the sound.</p>
<p>Return</p> 	<p>Tap to return to the Main screen.</p>
<p>Microphone</p> 	<p>To speak through the camera's speaker, using your Android or Apple device, tap and hold this icon and speak; the voice will be heard through the camera's speaker.</p>

To Take Snapshots

- 1 From the Main screen, tap to remote view your camera system. If you have accessed live video previously, a still picture will appear instead of the arrows.

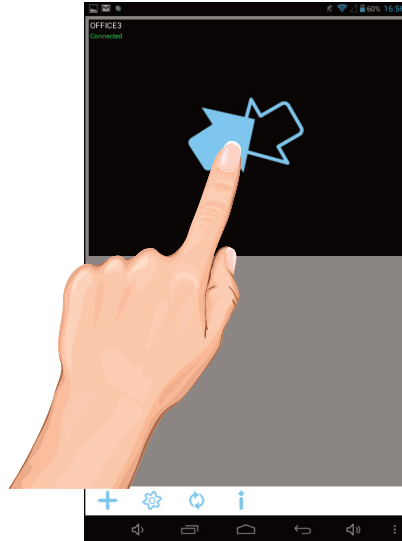

- 2 Tap the **Capture** icon to take a snapshot of the current image; "Snapshot is successful" will appear briefly on the screen.

To View Snapshots

FOR iOS:

Your snapshots will be named with the time stamp and saved into the Camera Roll > snapshot folder on your Apple device.

FOR ANDROID:

Your snapshots will be named with the time stamp and saved into the Photo gallery > snapshot folder on your Android device.

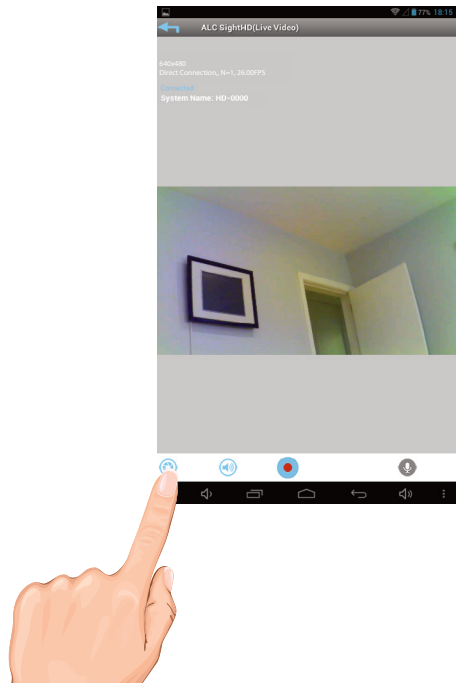

To Take Snapshots

- 3 PINCH AND ZOOM:** To zoom in or out, use the simple pinch and zoom gesture with this app.

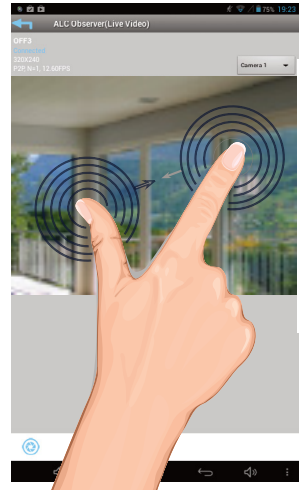

To View and/or Take Videos

1 From the main screen, tap to remote view your camera system. If you have accessed live video previously, a still picture will appear instead of the arrows.

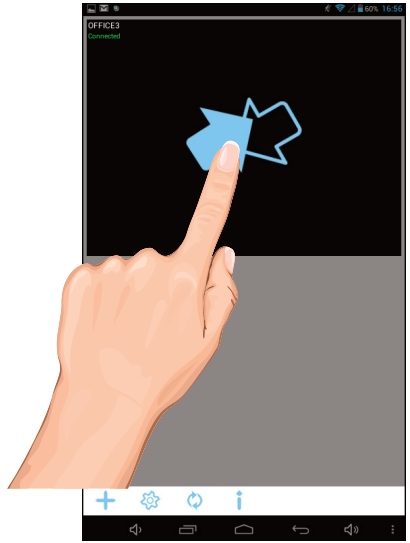

2 Tap the **Record** icon to start recording; the Record icon will appear and the App will record for approximately one minute. You cannot stop recording once you have begun; if you tap the Record icon while recording, "Device is recording" will appear briefly on the screen. See page 26 to play back videos.

Note: An SD Card is needed. If no SD card is inserted, "NO SD CARD" message will appear briefly. See page 9 for details.

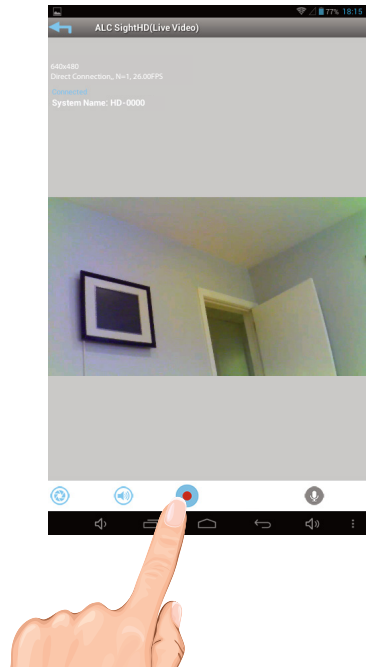

To View and/or Take Videos

- 3 **PINCH AND ZOOM:** To zoom in or out, use the simple pinch and zoom gesture with this app.

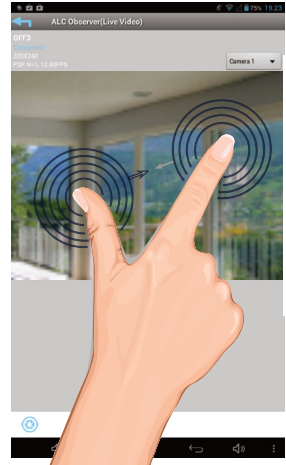

Motion Recordings

- 1 When motion is detected on the video camera, the camera will automatically record for one minute and then stop recording. See Sensitivity Settings on page 40.

Camera Speaker Features

- 1 **MUTE/UN-MUTE:** When in the SightHD App, tap the Speaker icon to hear the sound of the camera's microphone through the SightHD App. Tap again to mute the sound.

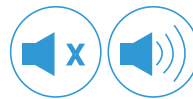

- 2 **MICROPHONE:** To speak through the camera's speaker using your Android or Apple device, tap and hold this icon and speak; the voice will be heard through the camera's speaker.



To Play Videos

- 1 From the main screen, tap the **Settings** icon.

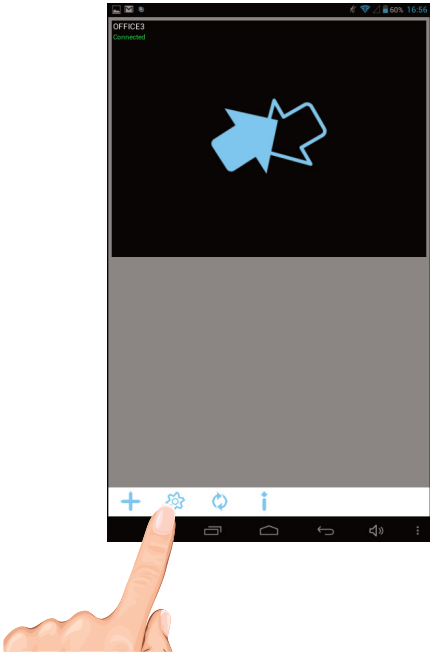

- 2 Tap the **Events** icon; the "Select Event Filter" pop-up will appear. For Apple, see note below.

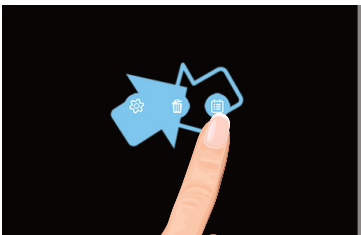

APPLE: You must tap the **Search** (Magnifying glass) icon to bring up the Events screen.

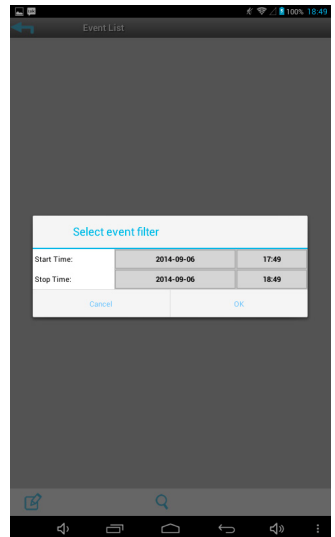

To Play Videos

- 3 Select the desired Start Time/Date of the videos you want to view by tapping on the respective option (date or time) and then tapping “+” or “-” to adjust. When finished, tap **Done**.



- 4 Repeat for Stop Time/Date, then tap **OK**; the Events List will appear.

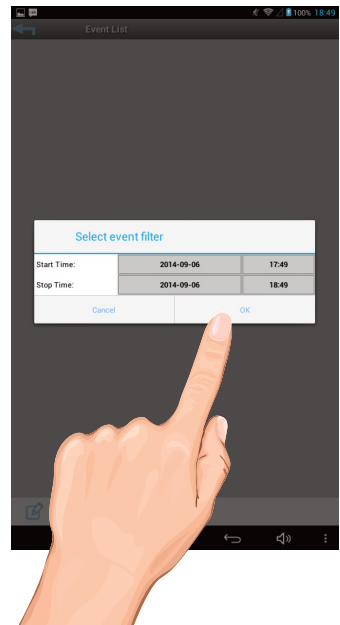

To Play Videos

5 Tap the video name once to play the video clip.

When playing back a video, tap the **Pause** icon to pause the video. Tap again to resume.

Tap the **Mute** icon to mute the sound, tap again to resume sound.

When the end of the recording is reached, "Playback end" will appear briefly on the screen.

DOWNLOAD A VIDEO: To download a video to your Android or Apple device, press and hold the file name and it will download to your device.

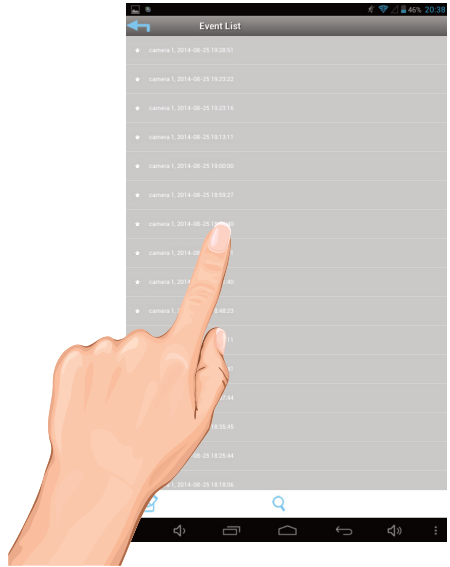

6 To Set Display Filter: To filter the Date/Time again, simply tap the **Magnifying Glass** while in the Events List.

TIP: When you set a filter, be sure the Time Zone feature is set accurately in the monitor to reflect the current time zone the camera is in, not the time zone where you are. See page 39.

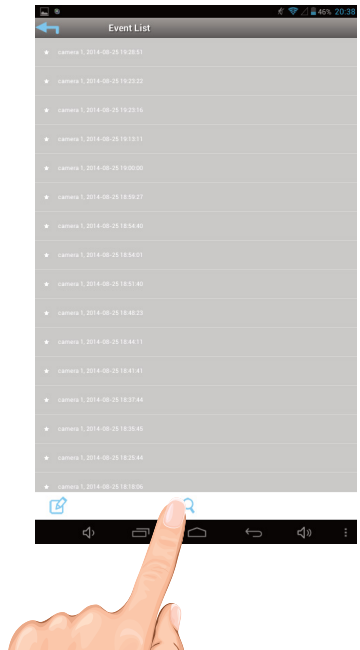

To Delete Recordings

1 Access the Events List as shown on pages 26 and 27.

If using an Android device, tap the **Edit** icon.

If using an Apple Device, go to the next step.



2 To Delete one file:

ANDROID: Select the file you wish to delete (a check mark will appear in the box to the right of the selected file) then tap the **Delete Selected** icon.

A pop-up box will appear asking you to confirm; tap **Yes**.

APPLE: Tap Delete One (“-” will appear next to the files). Tap the “-” and then tap **Delete** to delete the file.

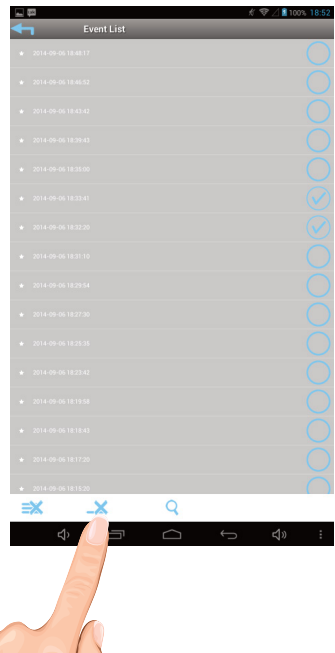

ANDROID TIP: To delete several files at the same time, select the files you wish to remove (check marks will appear to the right of the selected files) then tap the **Delete Selected** icon.

To Delete Recordings

3 To delete all files, tap the **Delete All** icon.

A pop-up box will appear asking you to confirm; tap **Yes**.

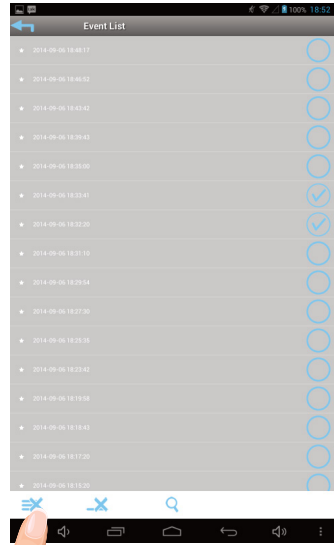
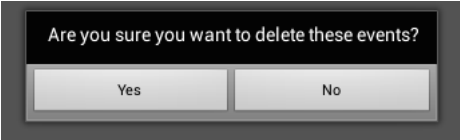

Information Screen Options

- 1 From the main screen, tap the **Information** icon; a pop-up will appear.

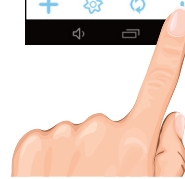
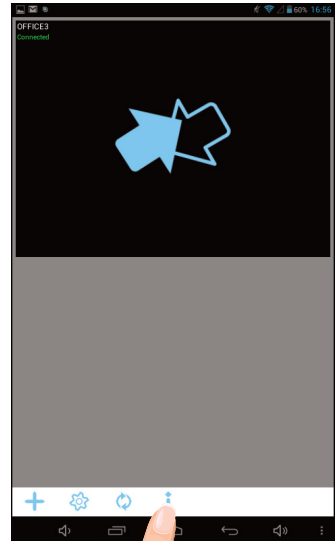

- 2 To view information (Version, etc.), tap **About**.

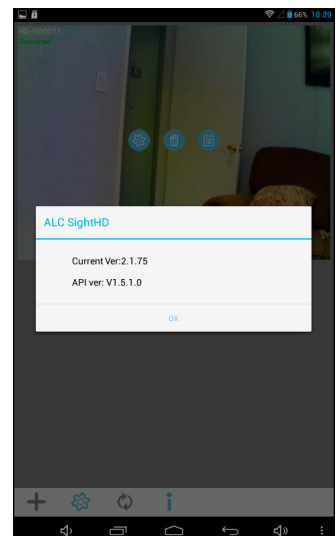
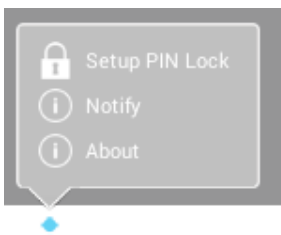

Information Screen Options

3 ANDROID DEVICES: To set up the App so you will be notified when motion has been detected, tap **Notify**.

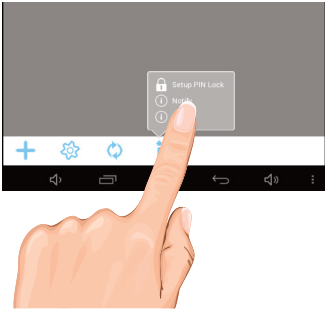

Tap the **Notify Enable** box, then tap **OK**. When motion is detected, you will receive notifications.

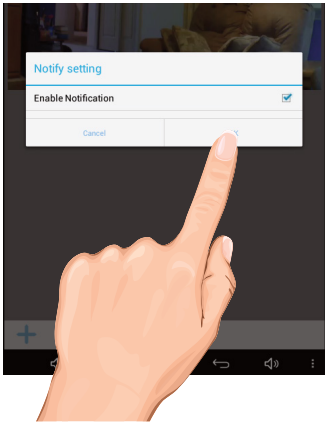

APPLE DEVICES:

- 1 Launch Settings/System Preferences from your Home screen on the Apple device.
- 2 Tap Notification Center; a list of Apps will appear.
- 3 Scroll down to find "ALC SightHD" App and click on it.
- 4 The Setting screen displays. Turn the notification ON or OFF as desired.
 Note: It takes time for the changes to take effect in iOS, normally within two hours.

Information Screen Options

4 To Setup the Pin Lock, tap **Setup PIN Lock**.

TIP: Setting a PIN Lock code will prevent others from activating the app and viewing your camera images.

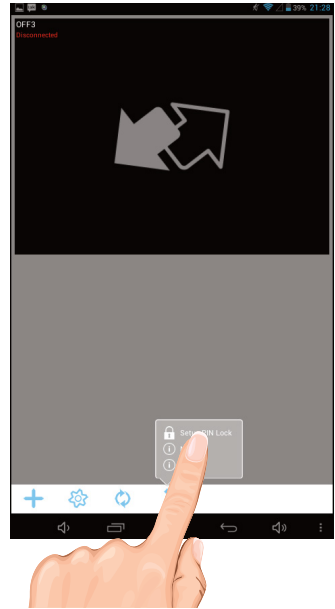

5 Tap the **Enable Lock When Starting** switch to enable (will be blue), or disable (will be white) the Pin Lock.

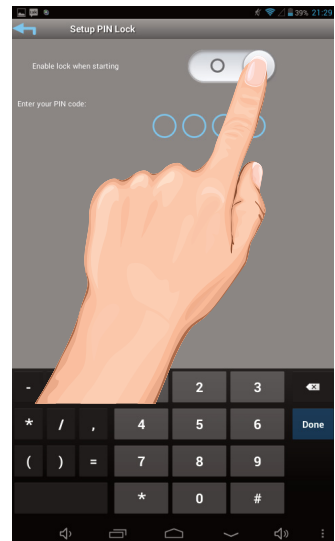

Information Screen Options

6 Using the keyboard, enter a four-digit code. Then confirm this exact code.

7 Now that the Pin is set and enabled, whenever the App is opened you must enter this code.

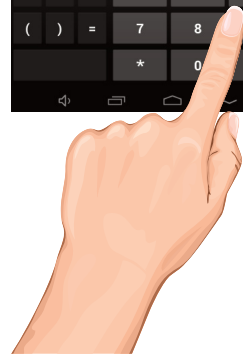
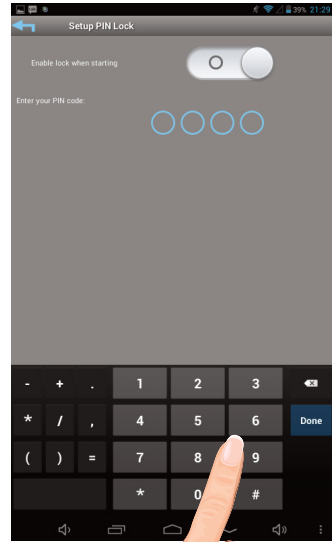

DID Setting Screen

- 1 From the main screen, tap the **Settings** icon.

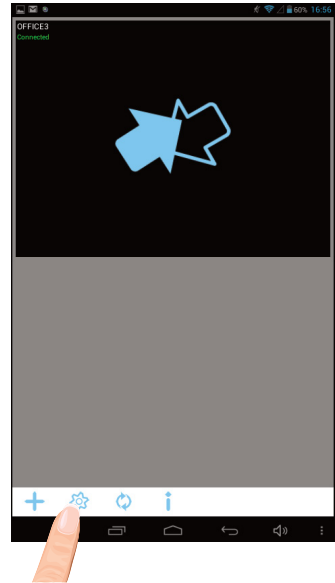

- 2 Tap the **Settings** icon; the System Information Screen will appear.

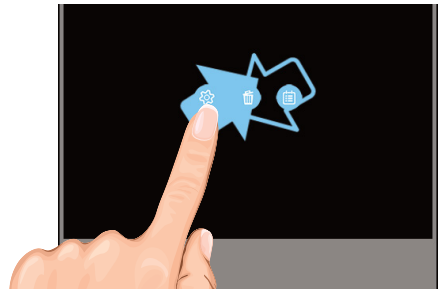

DID Setting Screen

3 Simply tap on a field to change it.

To enable Email Alert, which will email your Gmail account whenever motion is detected, simply tap the **Enable Email Alert** switch so it is blue.

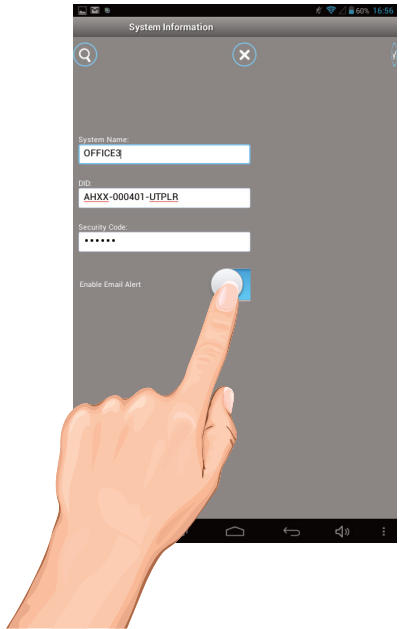

Advanced Settings

- 1 From the main screen, tap the **Settings** icon.

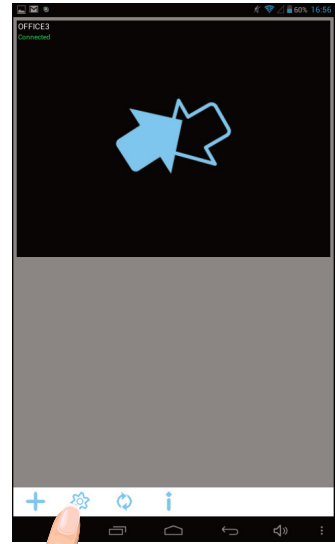

- 2 Tap the **Settings** icon; the System Information Screen will appear.

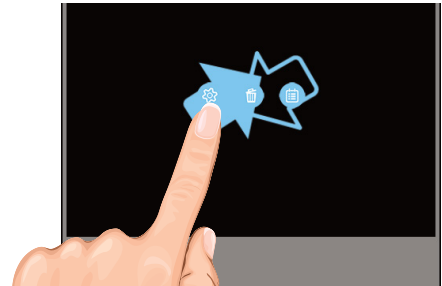

Advanced Settings

3 Tap on the **Advanced Settings** icon.

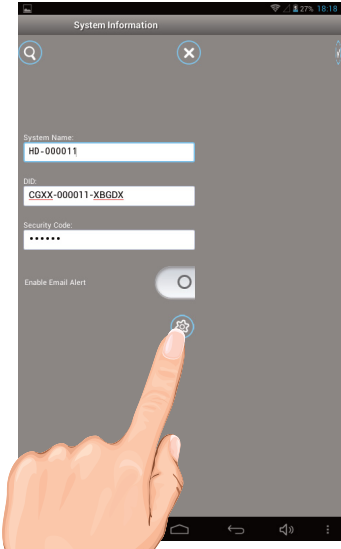

4 Enter your Admin password (Default is 123456 unless it was changed), then tap **OK**.

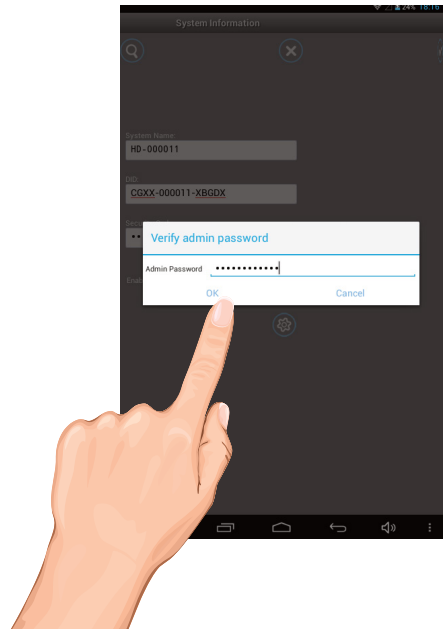

Advanced Settings

5 The following screen will appear. Scroll on the device to view the lower options.

Perform the following on this screen:

ADMIN PASSWORD: Tap to change the Admin Password from the default 123456. Admin Password is used to get into this screen.

TIME ZONE: Tap to change/set the Time Zone where the camera is located.

DAYLIGHT SAVING TIME: Tap to turn Daylight Saving Time on or off.

DEVICE SECURITY CODE: Tap to change the Security Code which is used to access the camera.

VIDEO QUALITY: Tap to set the Video Quality. Tapping **Better Streaming** will allow for faster video streaming, but the picture will not be as clear. Tapping **HD Video** will give the best video but will be slow. Tapping **Better Image** will provide mid speed and mid video picture.

SCREEN ORIENTATION: Tap to select the desired screen orientation; Normal, Flip, Mirror or Flip & Mirror.

ENVIRONMENT MODE: Tap to select the frequency used in your area. North America uses 60Hz, European countries use 50Hz.

LOW LIGHT ENHANCEMENT: Tap to set the Low Light Enhancement. 5 will provide the brightest enhancement and 1 the lowest.

WI-FI SETTING: The Wi-Fi setting allows you to choose the home network and setup the Wi-Fi environment. When you tap **Wi-Fi Setting**, the system automatically scans the nearby network and shows the available Wi-Fi routers in the list. Choose the Wi-Fi router connected to the home network and enter the Wi-Fi router password if necessary. Due to security concerns, it is suggested to use the WPA/WPA2/WPA2-PSK protocol for the Wi-Fi network.

SSID (Android): This is the network the camera is connected to.



NOTES:

- Some changes will result in the camera rebooting. If it does, re-launch the App when you see the green Status indicator light.
- The camera is designed to work with the legal Wi-Fi channels in your region. Please refer to your Wi-Fi router manual to choose an appropriate channel for the camera.

Continued on the Next Page

Advanced Settings

NOTIFY ENABLE (Apple only): Tap to turn this option on and you will be notified when motion has been detected.

SENSITIVITY SETTINGS: Tap **Detect Mode** to set the desired Sensitivity Settings as follows:

Off: Turns sensitivity off.

Software: Uses advanced software along with the Passive Infrared Sensor to achieve optimal motion sensitivity.

When set to software, you can then set the Motion Detection sliders for Day and Night.

EMAIL SETTING (Only used with Gmail accounts): Tap to set your Gmail account in order to receive email alerts. Fill in the following fields:

USE SSL: Tap the SSL switch to transmit the data with encryption. This setting requires the Simple Mail Transfer Protocol (SMTP) configuration. Most ISPs use the SMTP method to transfer outbound mail via the internet. Only use the SMTP that supports SSL.

SMTP SERVER: This should be smtp.gmail.com.

SMTP PORT: Enter 465.

USERNAME: Enter your Gmail username.

PASSWORD: Enter your Gmail password.

RECEIVER: Enter the email address you want the alerts to go to. (This can be different than the SMTP outgoing email account.)

Tap the check-mark when done.

SD CARD FORMAT: Tap and then confirm to format the microSD card inserted in the camera.

OVERWRITE SD CARD: Tap this switch to activate. When activated, the camera will delete the oldest recordings in order to record new files when the MicroSD card is full.

DEVICE PROFILE SETTING - LOAD: Tap to load in a previously saved Profile (Time Zone, Video Setting, Sensitivity, Email and Overwrite). This is useful if you want to apply the same settings to another camera quickly.

DEVICE PROFILE SETTING - SAVE: Tap to save the current Advanced Settings (Time Zone, Video Setting, Sensitivity, Email and Overwrite).

DEVICE INFORMATION: Tap to view the device information, including current firmware version, total size and free size (space available).

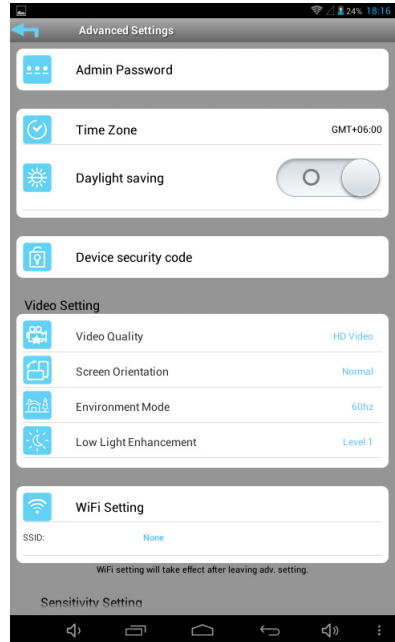

Cameras

When dust and grime builds up on the camera lens and glass, it will affect the night vision capability. The infrared light reflects off of the dust and grime, limiting the camera's "vision." Use a microfiber cloth to regularly clean the camera or when night vision video is cloudy or unclear.

If you have any trouble with your system, try these simple steps which should handle most common issues.

Problem	Possible Solution
The App cannot locate the camera.	<p>Make sure the camera's power is on.</p> <p>Make sure your network supports DHCP protocol.</p> <p>Make sure the camera and mobile device are on the same network or router.</p> <p>Use the Add Camera feature to manually add the camera.</p> <p>Make sure the home network is selected.</p>
No Image appears.	<p>Make sure the camera's power is on.</p> <p>Make sure the power adapter is not damaged or defective and plugged into an electrical outlet with power.</p> <p>Relocate the camera to obtain the best reception of wireless signal.</p> <p>Make sure the camera is properly configured in App.</p> <p>Make sure the mobile device is connected to 3G/4G/Wi-Fi properly.</p>
Poor picture quality.	<p>Clean the camera lens using a microfiber cloth.</p>
The motion sensor does not respond to movement.	<p>Ensure the MicroSD card is inserted into the camera.</p> <p>There might be no movement detected, i.e. no moving object to trigger the motion sensor.</p>
The App cannot record any video clips.	<p>Make sure the camera's power is on.</p> <p>Make sure the MicroSD card has been correctly inserted.</p> <p>Make sure the motion detection function has been enabled (see page 40).</p> <p>Format the MicroSD card when it is used for the first time.</p> <p>Make sure you are using a Class 10 rated memory card.</p>
Email Alert is not working.	<p>Make sure the email alert function is enabled.</p> <p>A Gmail account is suggested for the email alert function.</p> <p>Make sure you have setup the system configuration as suggested in the Email Alert section.</p> <p>Make sure the email address has been correctly entered.</p>

Problem	Possible Solution
A white image appears at night.	The camera's infrared LEDs shine invisible light that reflects off of surfaces such as glass and will cause white light.
Memory card error.	<p>Make sure the MicroSD card is correctly inserted in the camera and formatted.</p> <p>Make sure you are using Class 10 rated memory card.</p>
Wrong data and time are shown.	<p>Wrong date and/or time will result in unexpected record schedule.</p> <p>Make sure you have selected the correct time zone.</p> <p>Confirm the system date/time of the mobile device to ensure correct operation.</p> <p>Clock will set itself when connected to the internet. Make sure the system is connected properly to the internet.</p> <p>You may use your mobile device to access the system to see if remote view is functioning properly.</p>

Factory Default/Reset

Insert a paper clip or similar object into the Reset hole for five seconds and the system will start the reset process. The system will restore to factory default settings and you may start the Wi-Fi setup.

Upgrading the Firmware

Please go to www.ALCWireless.com/support for the latest firmware and installation procedures.

Camera

Communication Range	500 ft (164 yards) in open space
Camera Resolution - Single Camera	1280 x 720
Operating Temperature	14°F ~ 122°F (-10°C ~ 50°C)
Operating Voltage.....	DC 5V, 1.5A
Current Consumption	500 mA (MAX)
Night Vision	15 ft (4.5 m)
Dimensions.....	3.75 x 3.25 x 3.50 (96 x 83 x 89 mm)
MicroSD Card Time (4GB)	150 Events (HD/Better)/180 Events (Better Streaming)
MicroSD Card Time (8GB)	300 Events (HD/Better)/360 Events (Better Streaming)
MicroSD Card Time (16GB)	600 Events (HD/Better)/720 Events (Better Streaming)
MicroSD Card Time (32GB)	1,200 Events (HD/Better)/1,440 Events (Better Streaming)

One-Year Limited Warranty

Important: Evidence of original purchase is required for warranty service.

Atoms Labs LLC (“ALC”) ELEMENTS OF WARRANTY: ALC warrants, if properly installed and used thereafter in strict accordance with the use and care guidelines provided in the instructions manual, the Product shall be free from manufacturing defects in material and workmanship for one (1) year from the documented date of purchase. The purchase date must be documented with either an original sales receipt from the first retailer selling the Product or by credit card receipts or statements. The warranty is non-transferrable.

LIMITED WARRANTY: The warranty terminates one year after the date of original retail sale. The warranty is invalid if the Product is (A) damaged or not maintained as reasonable or necessary, (B) modified, altered, or used as part of any conversion kits, subassemblies, or any configurations not sold by ALC, (C) improperly installed, (D) serviced or repaired by someone other than an authorized ALC service center for a defect or malfunction covered by this warranty, (E) used in any conjunction with equipment or parts or as part of any system not manufactured by ALC, or (F) installed or programmed by anyone other than as detailed by the owner’s manual for this product.

THIS WARRANTY DOES NOT COVER DATA LOSS, OR COSTS RELATED TO DATA RECOVERY. ALC MAKES NO WARRANTY THAT ANY SOFTWARE PROVIDED WITH THE PRODUCT WILL FUNCTION WITHOUT INTERRUPTION OR OTHERWISE BE FREE OF ANOMALIES, ERRORS OR VIRUSES. THIS WARRANTY DOES NOT COVER ANY COSTS RELATING TO REMOVAL, REPLACEMENT, OR INSTALLATION OF ANY PRODUCT, REGARDLESS OF WHETHER THE PRODUCT IS FOUND BY ALC TO BE DEFECTIVE, OR SOFTWARE INSTALLED ON THE USER’S COMPUTER.

ALC DOES NOT MAKE ANY CLAIMS OR WARRANTIES OF ANY KIND WHATSOEVER REGARDING THE PRODUCT’S POTENTIAL, ABILITY OR EFFECTIVENESS TO PREVENT, MINIMIZE, OR IN ANY WAY AFFECT PERSONAL OR PROPERTY DAMAGE OR INJURY. ALC IS NOT RESPONSIBLE FOR ANY DAMAGE, LOSS OR THEFT RELATED TO THE PRODUCT OR TO ITS USE FOR ANY HARM, WHETHER PHYSICAL OR MENTAL RELATED THERETO. ANY AND ALL CLAIMS OR STATEMENTS, WHETHER WRITTEN OR VERBAL, BY SALESPEOPLE, RETAILERS, DEALERS OR DISTRIBUTORS TO THE CONTRARY ARE NOT AUTHORIZED BY ALC AND DO NOT AFFECT THIS PROVISION OF THIS WARRANTY. THE LIMITED WARRANTY IS THE SOLE AND ENTIRE WARRANTY PERTAINING TO THE PRODUCT AND IS IN LIEU OF AND EXCLUDES ALL OTHER WARRANTIES OF ANY NATURE WHATSOEVER, WHETHER EXPRESS, IMPLIED OR ARISING BY OPERATION OF LAW, INCLUDING, BUT NOT LIMITED TO ANY IMPLIED WARRANTIES OF MERCHANTABILITY OR FITNESS FOR A PARTICULAR PURPOSE. THIS WARRANTY DOES NOT COVER OR PROVIDE FOR THE REIMBURSEMENT OR PAYMENT OF LOST REVENUE, PROFIT, OR DATA, OR FOR SPECIAL, INDIRECT, CONSEQUENTIAL, INCIDENTAL, OR PUNITIVE DAMAGES HOWEVER CAUSED AND REGARDLESS OF THE THEORY OF LIABILITY. Some states do not allow this exclusion or limitation of incidental or consequential damages so the above limitation or exclusion may not apply to you. Your damages will be limited to the total purchase price you paid for the Product.

Use of audio or video equipment for recording the image of a person without their knowledge and consent is prohibited in certain states or jurisdictions. The end-user assumes all liability for compliance with applicable state, local and federal laws. Atoms Labs has no responsibility or liability for how the end-user uses a product. Wireless cameras require a wired connection to AC power outlet. Network conditions and environmental factors can adversely affect wireless signal range. Actual night vision range and image clarity depends on installation location, viewing area and light reflection / absorption.

This Product may only be sold in the United States of America and Canada. There is no warranty whatsoever on the Product outside of the United States of America and Canada.

STATEMENT OF REMEDY: If the Product is under warranty, ALC will either, at its option, repair or replace the defective Product and return it to you without charge for parts, service, or any other cost. ALC, at its option, may replace the Product with a new or refurbished Product.

LEGAL REMEDIES: This limited warranty gives you specific legal rights, and you may also have other rights which vary from state to state. All parties irrevocably submit themselves to the exclusive venue and personal jurisdiction of the state and federal courts in Denton County, Texas with regard to any dispute relating to this Warranty or its enforcement. The parties also hereby waive any challenge to venue and personal jurisdiction they may have to a lawsuit filed in a state or federal court in Denton County, Texas, regarding a dispute between the parties relating to this Warranty or its enforcement. You agree that Atoms Labs is entitled to its reasonable and necessary attorney's fees if it is a prevailing party in litigation against you relating to this Warranty. If any provision of this Warranty is found to be invalid, illegal, or unenforceable, the validity, legality, and enforceability of any of the remaining provisions will not in any way be affected or impaired and a valid, legal, and enforceable provision of similar intent and economic impact will be substituted therefore.

PROCEDURE FOR OBTAINING PERFORMANCE OF WARRANTY: If, after following the instructions in the owner's manual you are certain that the Product is defective, pack the Product carefully (preferably in its original packaging). The Product should include all parts & accessories originally packaged with the Product. Include evidence of original purchase & a note describing the defect that has caused you to return it. The Product should be shipped freight prepaid, by traceable means, to warrantor at:

Atoms labs LLC
2670 Firewheel Drive Suite D
Flower Mound, TX 75028
844-767-8544

9 a.m. to 6 p.m., Central Time, Monday through Friday

ALC reserves the right to make changes to its products without incurring any obligation to modify any product that has already been manufactured. This warranty does not cover any alteration or damage to any other software that may be or may become resident on the users system as a result of installing any software provided.

ALC appreciates your support and feedback! If you come across software bugs or ways we could improve our products, we would love to hear about them! Please email us at support@ALCWireless.com and you will hear back from us.

©2014 Atoms Labs LLC, All rights reserved. iPhone, iPad, iPod Touch, and App Store are registered trademarks of Apple, Inc. Chrome and Android are registered trademarks of Google, Inc. Certain other product names, brand names, and company names may be trademarks or designations of their respective owners.

Use of audio or video equipment for recording the image of a person without their knowledge and consent is prohibited in certain states or jurisdictions. The end-user assumes all liability for compliance with applicable state, local and federal laws. Wireless cameras require a wired connection to AC power outlet. Network conditions and environmental factors can adversely affect wireless signal range. Actual night vision range and image clarity depends on installation location, viewing area and light reflection / absorption. Lithium-ion battery must be recycled or disposed of properly. Lithium-ion battery must be recycled or disposed of properly. Photography and illustration may differ slightly from actual product.



FCC Compliance Statement: This device complies with Part 15 of the FCC rules. Operation is subjected to the following two conditions: (1) this device may not cause harmful interference, and (2) this device must accept any interference received, including interference that may cause undesired operation.



Products with CE Marking comply with EMC Directive (2004/108/EC); Low Voltage Directive (73/23/EEC); R&TTE (1999/5/EC); ROHS Directive (2011/65/EU) issued by the Commission of the European Community. Compliance with these directives implies conformity to the following European Norms: EMC: EN 301 489 LVD: EN 60950 Radio: EN 300 328



If the camera system no longer functions or can no longer be repaired, it must be disposed of according to the valid statutory regulations. Disposal of spent batteries/accumulators:

You are required by law (Battery Ordinance) to return all spent batteries and accumulators. Disposing of spent batteries/accumulators with common household waste is prohibited! Batteries/accumulators that contain hazardous substances are marked with the symbols on the side. These symbols indicate that it is prohibited to dispose of these batteries/accumulators in the household waste. The abbreviations for the respective heavy metals are: Cd=cadmium, Hg=mercury, Pb=lead. You can return spent batteries and accumulators that can no longer be charged to the designated collection points in your community, outlets or wherever batteries or accumulators are sold. Following these instructions will allow you to fulfill the legal requirements and contribute to the protection of our environment!

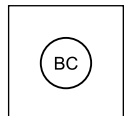



ALC™

Wireless Made Simple.

ALCWireless.com