

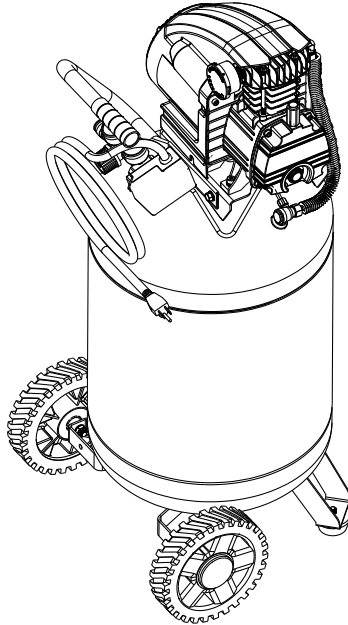

# 20-GALLON AIR COMPRESSOR



Intertek  
4000049

For replacement parts visit  
**WENPRODUCTS.COM**

Model # 2202  
[bit.ly/wenvideo](http://bit.ly/wenvideo)

## IMPORTANT:

Your new tool has been engineered and manufactured to WEN's highest standards for dependability, ease of operation, and operator safety. When properly cared for, this product will supply you years of rugged, trouble-free performance. Pay close attention to the rules for safe operation, warnings, and cautions. If you use your tool properly and for intended purpose, you will enjoy years of safe, reliable service.



## NEED HELP? CONTACT US!

Have product questions? Need technical support?  
Please feel free to contact us at:

 **800-232-1195** (M-F 8AM-5PM CST)

 [techsupport@wenproducts.com](mailto:techsupport@wenproducts.com)

 **WENPRODUCTS.COM**

## TABLE OF CONTENTS

---

Technical Data .....	2
General Safety Rules .....	3
Specific Safety Rules for Compressors .....	4
Electrical Information .....	6
Know Your Compressor .....	7
Assembly .....	8
Operation .....	8
Maintenance .....	10
Troubleshooting .....	11
Parts List & Exploded View .....	12
Warranty .....	14

## TECHNICAL DATA

---

Model Number:	2202
Motor:	120V, 15A, 60 Hz, 3 Wire
Capacity:	20 Gallon
Max PSI:	135 PSI
Approximate Cut-in Pressure:	105 PSIG
Approximate Cut-out Pressure:	135 PSIG
Air Outlet:	Quick-Coupler, 1/4" NPT
Air Flow:	3.8 CFM at 90 PSI 5.0 CFM at 40 PSI
Duty Cycle:	50%
Compression Process:	Single Stage
Product Dimensions:	19.5 x 17.5 x 42 inches
Weight:	86 pounds

# GENERAL SAFETY RULES

---

Safety is a combination of common sense, staying alert and knowing how your item works.

## **SAVE THESE SAFETY INSTRUCTIONS.**



**WARNING!** Read all safety warnings and all instructions. Failure to follow the warnings and instructions may result in electric shock, fire and serious injury. To avoid mistakes and serious injury, do not plug in your tool until the following steps have been read and understood.

### **WORK AREA SAFETY**

1. Keep work area clean and well lit. Cluttered or dark areas invite accidents. Do not work on floor surfaces that are slippery with sawdust or wax. Keep the ground clear of tripping hazard.
2. Do not operate power tools in explosive atmospheres, such as in the presence of flammable liquids, gases or dust. Power tools create sparks which may ignite the dust or fumes.
3. Keep bystanders at a safe distance from the work area. Never allow children or pets near the tool.

### **ELECTRICAL SAFETY**

1. Do not expose power tools to rain or wet conditions. Water entering a power tool will increase the risk of electric shock.
2. Power tool plugs must match the outlet. Never modify the plug in any way. Modified plugs with non-matching outlets will increase the risk of electric shock.
3. Check all power supplies periodically. Do not use defective cords. Damaged or entangled cords increase the risk of electric shock.
4. Do not abuse the cord. Never use the cord for carrying, pulling or unplugging the power tool. Keep cord away from heat, oil, sharp edges or moving parts.

### **PERSONAL SAFETY**

1. Stay alert. Watch what you are doing and use common sense when operating a power tool. Do not use a power tool while you are tired or under the influence of drugs, alcohol or medication. A moment of inattention while operating power tools may result in serious personal injury.
2. Do not wear loose clothing, gloves, neckties, or jewelry (rings, watches, etc.) when operating the tool. Inappropriate clothing and items can get caught in moving parts and draw you in. Always wear non-slip footwear and tie back long hair.
3. Use personal protective equipment. Always wear safety goggles at all times that comply with ANSI Z87.1. Use ear protection such as plugs or muffs during extended periods of operation. Wear work gloves to protect your hands. Wear a face mask or dust mask to fight the dust.
4. Keep proper footing and balance at all times and do not overreach when operating the power tool.



**WARNING:** Dust generated from certain materials can be hazardous to your health. Always operate the tool in a well-ventilated area and wear dust mask. Use dust collection systems when processing wood and plastics. Dust extractors or dust bags must not be connected when processing metals.

# GENERAL SAFETY RULES

---

## POWER TOOL USE AND CARE

1. Avoid accidental start-ups. Make sure the power switch is in the OFF position before connecting the plug to a power source or carrying the tool.
2. Check power tool for damaged parts. Check for misalignment of moving parts, jamming, breakage, improper mounting, or any other conditions that may affect the tool's operation. Do not use the power tool if the switch does not turn ON/OFF. Any part that is damaged should be properly repaired or replaced before use.
3. Do not force the tool to do a job for which it was not designed. Use the correct power tool and accessories and follow the instructions for your application to prevent hazardous situations.
4. Remove adjustment tools. Always make sure all adjustment tools or wrenches are removed from the tool before turning on the power tool.
5. Keep guards in place and in working order before operating the tool. All protection and safety devices must be in place after completing repair and maintenance procedures.
6. Never leave a running tool unattended. Do not leave the tool until it has come to a complete stop.

## POWER TOOL MAINTENANCE

1. Always disconnect the power cord plug from the electrical outlet when making adjustments, changing parts, or storing power tools. Such preventive safety measures reduce the risk of starting the power tool accidentally.
2. Maintain power tools properly. Safely store power tools out of the reach of children. Always keep tools clean and in good working order. Follow instructions for lubricating and changing accessories.
3. Only have your power tool serviced by a qualified repair person using only identical replacement parts. Use of any other part can cause personal injury and damage to the tool.

## SPECIFIC RULES FOR AIR COMPRESSORS

---

**WARNING:** To avoid mistakes and serious injury, do not plug in your tool until the following steps have been read and understood.

1. Use your air compressor in accordance with these instructions, taking into account working conditions and the task at hand. Use of the compressor for operations other than its intended use could result in personal injury.
2. Always operate the compressor in a well ventilated area away from combustible materials, gasoline, or solvent vapors. Your air compressor must be kept at least 20 feet away from explosive vapors.
3. Do not use your air compressor if the pressure switch does not turn on and off. An air compressor that cannot be controlled with the switch is dangerous and must be repaired.
4. Check for misalignment or binding of moving parts, breakage of parts and any other condition that may affect your air compressor's operation. If damaged, have your air compressor repaired by a qualified service technician before using it again. Many accidents are caused by poorly maintained compressors.

## SPECIFIC RULES FOR AIR COMPRESSORS

5. Keep your air compressor in a well-ventilated area. Do not cover during use.
6. Do not spray flammable liquids in a confined area or towards a hot surface. The spray area must be well-ventilated. Do not smoke while spraying. Do not spray when a spark or flame is present.
7. Do not adjust the regulator higher than the marked maximum pressure of any attached pneumatic tools or equipment.
8. Do not direct the air stream at people or animals.
9. Do not use your air compressor to supply breathing air.
10. To prevent burns or other injuries, do not touch any exposed metal parts on compressor during or immediately after operation. The air compressor's cylinder head and air lines get hot during operation and will remain hot for several minutes after operation.
11. Do not leave your air compressor unattended for an extended period while plugged in. Unplug compressor and detach hoses and accessories after use.
12. Drain tank daily or after use. Internal rust causes tank failures and explosions.
13. Do not use the air hose to move your air compressor.
14. Do not grind, puncture, torch or in anyway modify the compressor's tank.
15. Disconnect the plug from the power source and drain all air from the tank before making any adjustments, changing accessories, or storing your air compressor. This reduces the risk of starting your air compressor accidentally.
16. Maintain your air compressor. Keep your air compressor clean for maximum performance. Follow the instruction for maintenance and changing accessories if necessary. Keep your air compressor dry, clean and free from oil and grease.
17. Store your air compressor out of the reach of children and do not allow people unfamiliar with either the compressor or these instructions to operate it. An air compressor is dangerous in the hands of an untrained user.
18. Ignoring any of the above rules and guidelines automatically voids the warranty for the unit.

# ELECTRICAL INFORMATION

## GROUNDING INSTRUCTIONS

IN THE EVENT OF A MALFUNCTION OR BREAKDOWN, grounding provides the path of least resistance for an electric current and reduces the risk of electric shock. This tool is equipped with an electric cord that has an equipment grounding conductor and a grounding plug. The plug **MUST** be plugged into a matching outlet that is properly installed and grounded in accordance with **ALL** local codes and ordinances.

**DO NOT MODIFY THE PLUG PROVIDED.** If it will not fit the outlet, have the proper outlet installed by a licensed electrician.

**IMPROPER CONNECTION** of the equipment grounding conductor can result in electric shock. The conductor with the green insulation (with or without yellow stripes) is the equipment grounding conductor. If repair or replacement of the electric cord or plug is necessary, **DO NOT** connect the equipment grounding conductor to a live terminal.

**CHECK** with a licensed electrician or service personnel if you do not completely understand the grounding instructions or whether the tool is properly grounded.

**CAUTION:** In all cases, make certain the outlet in question is properly grounded. If you are not sure, have a licensed electrician check the outlet.



**WARNING:** This tool is for indoor use only. Do not expose to rain or use in damp locations.

## GUIDELINES FOR EXTENSION CORDS

Make sure your extension cord is in good condition. When using an extension cord, be sure to use one heavy enough to carry the current your product will draw. An undersized cord will cause a drop in line voltage resulting in loss of power and overheating. The table below shows the correct size to be used according to cord length and nameplate ampere rating. When in doubt, use a heavier cord. The smaller the gauge number, the heavier the cord.

Make sure your extension cord is properly wired and in good condition. Always replace a damaged extension cord or have it repaired by a qualified person before using it.

Protect your extension cords from sharp objects, excessive heat and damp/wet areas.

Use a separate electrical circuit for your tools. This circuit must not be less than a #12 wire and should be protected with a 15 A time-delayed fuse. Before connecting the motor to the power line, make sure the switch is in the **OFF** position and the electric current is rated the same as the current stamped on the motor nameplate. Running at a lower voltage will damage the motor.

**WARNING:** This tool must be grounded while in use to protect the operator from electric shock.

AMPERAGE	REQUIRED GAUGE FOR EXTENSION CORDS (UL Recommendations)			
	25 ft.	50 ft.	100 ft.	150 ft.
15A	14 gauge	12 gauge	Not Recommended by UL	

# KNOW YOUR AIR COMPRESSOR

---

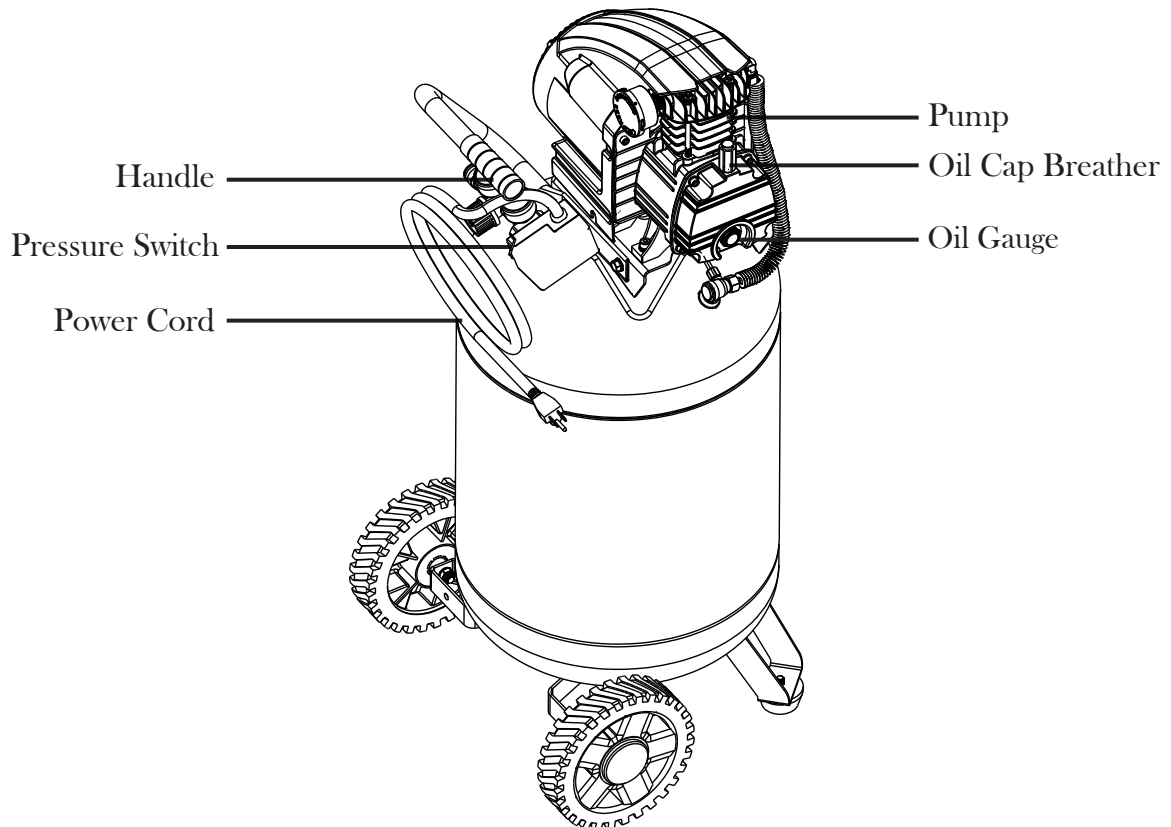
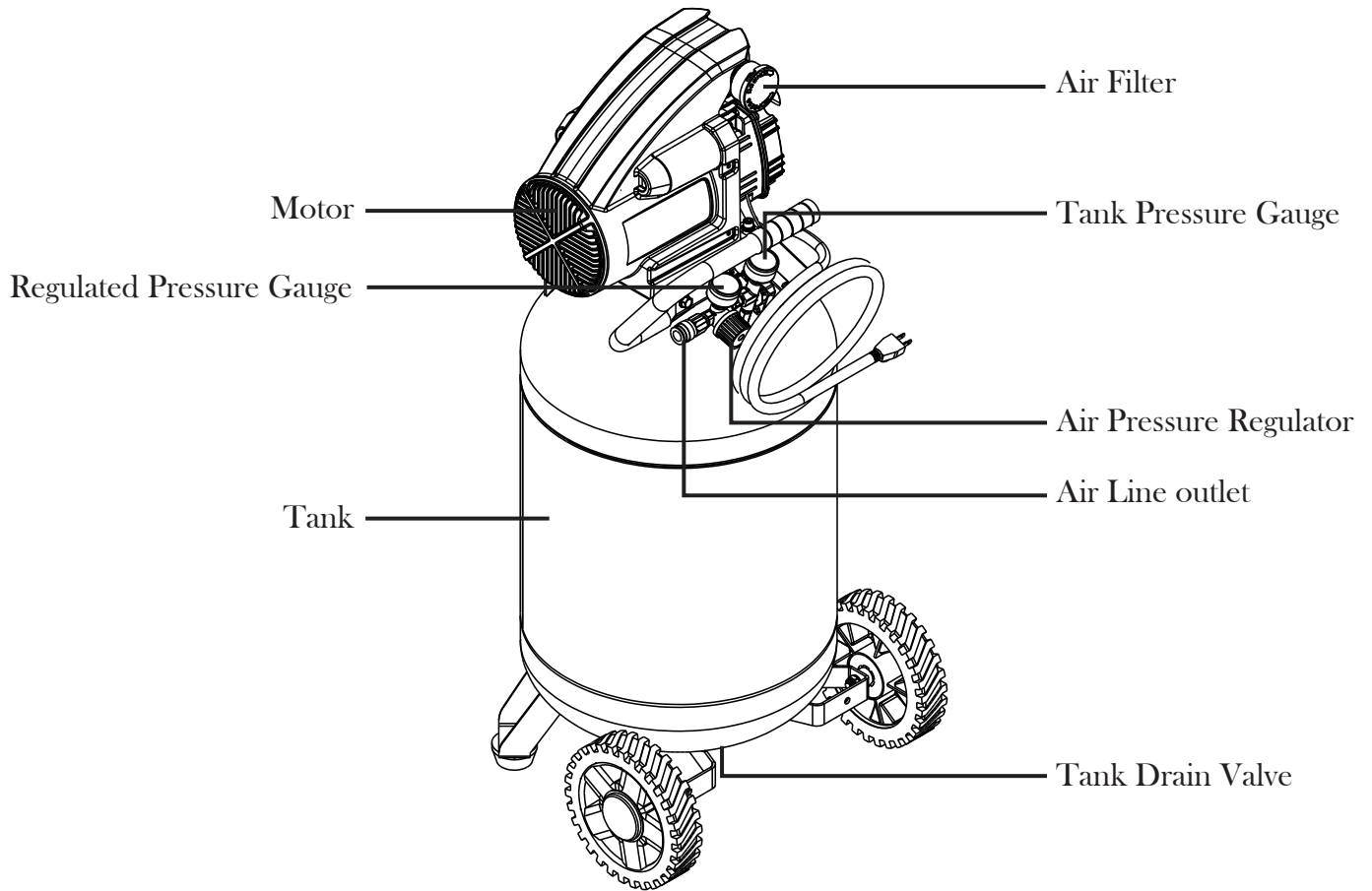

## ASSEMBLY

### INSTALLING THE WHEELS

Insert bolt M10X1.25X57 into the wheel through the 13mm flat washer, wheel bracket and 10mm flat washer. Tighten with M10X1.25 hex nut. Attached the hub cap on the outside of the wheel. Repeat for both wheels.

### INSTALLING THE AIR FILTER

Remove the plastic plug. Install the air filter (Fig. 2 - 1) before starting the air compressor.

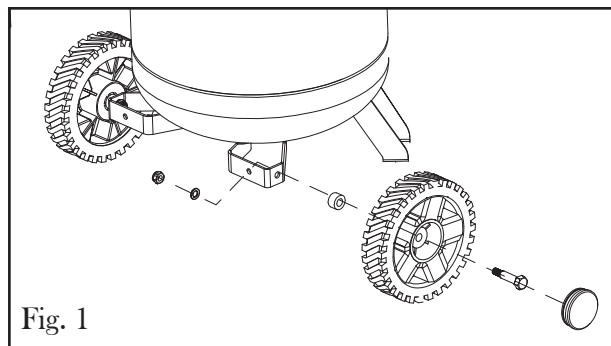

### INSTALLING THE OIL CAP BREATHER

Remove the plastic plug from the oil fill port (Fig. 2 - 3). Slowly fill with the provided semi-synthetic oil while observing the oil gauge (Fig. 2 - 4). Fill until the oil lands in the middle of the red circle between A and B (Fig. 3). Install the oil cap breather (Fig. 2 - 2) before starting the air compressor.

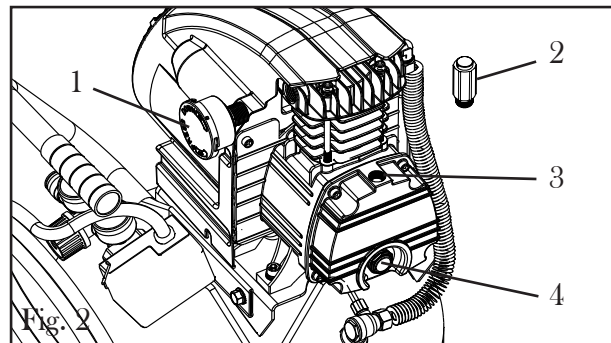

**WARNING:** Be sure to fill with semi-synthetic compressor oil before starting the machine.

### REFILLING OIL

Check the oil level before each operation. When the oil level is below B, refill the compressor with semi-synthetic compressor oil until the oil reaches the center of the red circle in the oil gauge. Do not let oil level exceed A (Fig. 3).

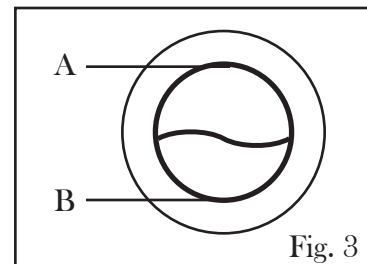

## OPERATION

### STARTING THE COMPRESSOR

1. Follow all instructions in the assembly guidelines outlined above before attempting to start the compressor. Do not start the generator until the air filter, oil cap breather and oil have been properly installed.
2. Inspect the machine components to make sure that there are no damaged or worn parts. Replace any damaged parts immediately. Only repair using identical replacement parts.
3. Check that the pressure switch is turned to OFF position and the tank drain valve is closed.
4. Connect an air hose (not included) to the air line inlet (Fig. 4 - 1). Make sure the air hose is rated high enough to handle the max PSI of the compressor.
5. Connect the electrical plug to a power supply. NOTE: the compressor must be at least one foot from any wall or obstruction in a well-ventilated area in order to maximize proper air flow. Do not cover the compressor.
6. Turn the pressure switch (Fig. 4 - 3) to the ON/AUTO position to allow the compressor to automatically start up and shut down depending on its need for air. NOTE: make sure this switch is set to OFF before unplugging, plugging in, or storing the compressor.



## OPERATION

**WARNING:** To prevent burns or other injuries, DO NOT touch the compressor while it is running. Allow it to cool before handling or servicing. Keep children away from the compressor at all times.

7. Allow the compressor to reach the desired PSI on the tank pressure gauge before turning off the compressor. If left on, the compressor will reach its maximum PSI of 135 and turn off automatically. Then once the tank PSI lowers to 105 PSI, the compressor will automatically turn back on until it reaches its max PSI again. Check the tank pressure gauge (Fig. 4 - 4). **DO NOT ALLOW THE COMPRESSOR TO FILL UP TO MORE THAN 135 PSI.**

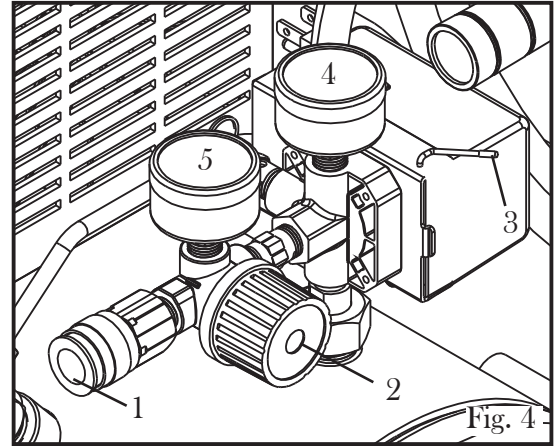

8. Turn the air pressure regulator (Fig. 4 - 2) to the desired position in order to control the output of air flow from the compressor. The regulated air pressure gauge (Fig. 4 - 5) will show you the current air flow from the air line outlet. Make sure that this pressure is not higher than the working pressure of any pneumatic tools hooked up to the compressor. Using a pressure higher than the rated pressure of an attached tool creates the possibility of damaging or, in worse case scenarios, bursting said power tool. Using a pressure that is too low for a tool can result in misfires and improper functionality.

### SHUTTING DOWN THE COMPRESSOR

1. Turn the pressure switch to the OFF position. Then unplug the power cord.
2. Reduce pressure in the tank through the outlet hose or by pulling the relief valve ring (Fig. 5 - 1).
3. Drain water from air tank by opening drain valve (counterclockwise) on the bottom of the tank.

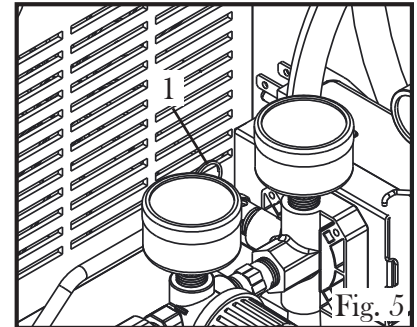

 **WARNING:** Wear safety goggles when opening drain valve. Escaping air and moisture may propel debris that may cause eye injury.

### THERMAL OVERLOAD PROTECTOR

The thermal overload protector shuts down the motor when it is overloaded. When the thermal overload trips, the air compressor will stop working. Let the motor cool down for a few minutes. To restart the motor, unplug the power cord and plug it back in.

## MAINTENANCE

---



**WARNING:** Always shut off and unplug the compressor and relieve all air pressure from the system before performing any cleaning or inspection on the air compressor.

### CLEAN AND INSPECT DAILY

1. Pull the pressure release valve ring to open the pressure release valve after each operation.
2. Open the tank drain valve underside the compressor to drain the tank daily after each operation. To minimize moisture inside of the unit, tip the compressor during drainage so that the drain valve is aimed directly towards the ground. This will allow all moisture to drain completely and prevent the tank from corrosion.
3. Wipe the tool clean. Blow the tool clean using high compressed air, then use non-flammable cleaning solutions to wipe exterior of the tool as necessary, particularly before storage. Do not soak tool with cleaning solutions. Such solutions can damage internal parts. Keep the handle clean, dry and free from slippery substances such as oil or grease.
4. Inspect the machine components before operation to make sure that there are no damaged or worn parts. Replace any damaged parts immediately. Do not operate if there are any damaged components. Only repair using identical replacement parts.
5. Do not overtighten connections to avoid creating leaks.

### CHECKING/CHANGING OIL

Check the oil level regularly from the oil gauge. The oil level must be between A and B (Fig. 6). Do not overfill or underfill. When the oil level is below B, refill with semi-synthetic compressor oil until the level reaches the center of the red circle in the oil gauge.

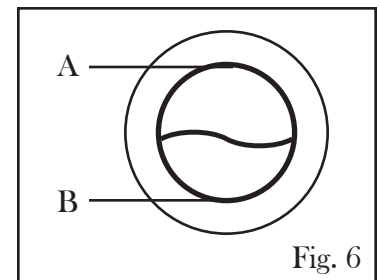

Oil should be changed after 200 hours of operation. Prepare a container to catch the oil and drain the oil from the oil gauge. The compressor may need to be tipped slightly to let the oil drain completely. After the oil has been drained, return the oil gauge back in place. Open the oil cap breather and fill the pump with semi-synthetic compressor oil until the oil level reaches the center of the red circle in the oil gauge (Fig. 6).

NOTE: Dispose of the collected oil responsibly at a public collection facility.

### TESTING FOR LEAKS

Make sure all connections are tight and secure before testing for leaks. A small leak in any hoses or connectors will greatly reduce the abilities of the compressor. To locate a leak, simply spray a mixture of soap and water across the entire surface of both the tank and the hose (wherever the leak is believed to be). Bubbles will begin to appear if a leak is indeed present. Fix immediately. Try to avoid getting soapy water near any of the inlets on the tank or the pump.

### STORAGE

Before storing the compressor, drain the tank by opening tank drain valve on the underside of the compressor. This will drain the compressor to prevent moisture from collecting and rusting the inside of the tank. Pulling on the air release valve located next to the tank pressure gauge will quickly empty out the tank. Do not store in cold climates, as cold climates may create problems with the motor while possibly freezing water condensation.

## TROUBLESHOOTING

---



**CAUTION:** Stop using the tool immediately if any of the following problems occur or risk serious personal injury. Have the repair or replacement performed by an experienced personnel before operating this tool.

Problem	Common Causes	Solution
Air leaks from the regulator. Regulator does not regulate pressure any more.	The regulator has become damaged or dirty.	Replace the regulator/internal parts.
Low PSI pressure and/or compressor does not stop.	<ol style="list-style-type: none"> <li>1. Tank drain valve (part no. 10) is open.</li> <li>2. Leaks in the unit.</li> <li>3. Using too much air.</li> <li>4. Air intake is obstructed.</li> <li>5. Compressor is too small.</li> <li>6. Blown gaskets or seals or leaking valves or piston rings.</li> </ol>	<ol style="list-style-type: none"> <li>1. Close the drain valve.</li> <li>2. Check the unit for leaks (see “Testing for Leaks” on page 8).</li> <li>3. Use less air.</li> <li>4. Make sure the unit is away from the wall and that the air inlets are not obstructed.</li> <li>5. Check the requirements of the pneumatic tool. Make sure the specifications of this compressor meet the requirements.</li> <li>6. Replace necessary parts.</li> </ol>
A large drop in the regulated pressure gauge occurs once a pneumatic tool or other air accessory is being used.	The compressor is too small.	Check the requirements of the pneumatic tool. Make sure the specifications of this compressor meet the requirements.
Motor won't run.	<ol style="list-style-type: none"> <li>1. Tank pressure is too high.</li> <li>2. Motor overload protection has been tripped.</li> <li>3. Power source isn't working.</li> <li>4. Check valve (part no. 11) is stuck open.</li> </ol>	<ol style="list-style-type: none"> <li>1. Motor will start automatically once the tank pressure drops.</li> <li>2. Let the motor cool down for a few minutes to reset the overload switch.</li> <li>3. Examine the power source. Make sure that your extension cord is a high enough gauge.</li> <li>4. Clean or replace the check valve.</li> </ol>
Pressure relief valve opens.	Either the tank pressure is too high or the pressure switch is stuck.	Replace the pressure switch.

**If there are still problems after consulting this list, or if you have any questions about the solutions provided above, feel free to contact the WEN help line at 800-232-1195 (M to F, 8 to 5 CST).**

# EXPLODED VIEW AND PARTS LIST

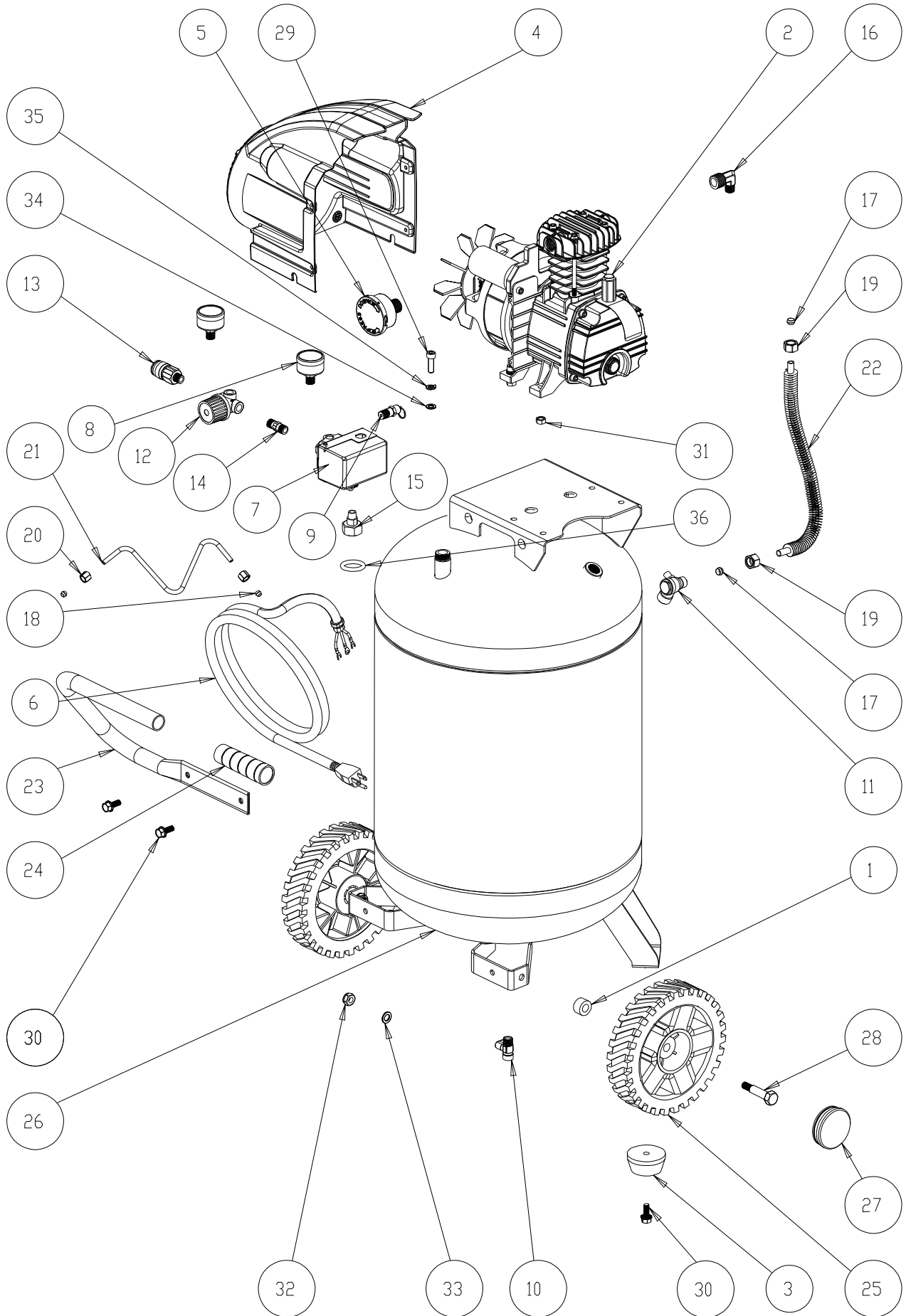

## EXPLODED VIEW AND PARTS LIST

<b>No.</b>	<b>Part No.</b>	<b>Description</b>	<b>Qty.</b>
1	2202-001	Flat Washer 13mm	2
2	2202-002	Pump L2 Outlet	1
3	2202-003	Isolator Foot Seals 60mm X 26mm	2
4	2202-004	Shroud L2	1
5	2289-005	Kit Air Intake Metal Housing 1/2-14 NPT	1
6	2289-006	Power Cord ST Type 6'	1
7	2202-007	Pressure Switch 4-Port 105-135PSI	1
8	2202-008	Pressure Gauge, 1.5", 1/4" NPT	2
9	2202-009	Safety Valve 150 PSI	1
10	2202-010	Drain Valve 1/4 Turn Small	1
11	2289-011	Check Valve	1
12	2289-012	Regulator 3-Port 1/4" NPT	1
13	2289-013	Quick Connect Fitting	1
14	2289-014	Nipple 1/4" NPT 35mm	1
15	2287-033	Stand Pipe Nipple Assembly with Nut	1
16	2202-016	Elbow 3/8" NPT-9/16	1
17	2289-017	Ferrule 3/8 Tubing	2
18	2289-018	Ferrule 1/4 Tubing	2
19	2289-019	Nut Compression 3/8 9/16Unef	2
20	2289-020	Nut Compression 1/4 7/16Uns	2
21	2202-021	Tube Pressure Relief L220 Vertical	1
22	2202-022	Tube Outlet L220 Vertical(With 100673003)	1
23	2202-023	Handle Half	1
24	2202-024	Grip Handle Rubber 25mm Tube	1
25	2202-025	8" X 1.75" Wheel	2
26	2202-026	Assembly Tank Weldment L220	1
27	2202-027	Hub Cap Wheel	2
28	2202-028	Bolt M10X1.25X57 Mfzn-C	2
29	2286-026	Screw SHC M8X1.25X30mm	4
30	2202-030	Screw HFH Serrated M8*20 ST	4
31	2289-032	Hex Nut M8	4
32	2289-033	Hex Nut Nylock M10X1.25	2
33	2289-034	Flat Washer 10mm	2
34	2289-036	Flat Washer 8mm	4
35	2289-038	Lock Washer 8mm	4
36	2287-034	O Ring ID14*3	1

## **LIMITED TWO YEAR WARRANTY**

---

WEN Products is committed to building tools that are dependable for years. Our warranties are consistent with this commitment and our dedication to quality.

### **LIMITED WARRANTY OF WEN CONSUMER POWER TOOLS PRODUCTS FOR HOME USE**

GREAT LAKES TECHNOLOGIES, LLC (“Seller”) warrants to the original purchaser only, that all WEN consumer power tools will be free from defects in material or workmanship for a period of two (2) years from date of purchase. Ninety days for all WEN products, if the tool is used for professional use.

**SELLER’S SOLE OBLIGATION AND YOUR EXCLUSIVE REMEDY** under this Limited Warranty and, to the extent permitted by law, any warranty or condition implied by law, shall be the repair or replacement of parts, without charge, which are defective in material or workmanship and which have not been misused, carelessly handled, or misrepaired by persons other than Seller or Authorized Service Center. To make a claim under this Limited Warranty, you must make sure to keep a copy of your proof of purchase that clearly defines the Date of Purchase (month and year) and the Place of Purchase. Place of purchase must be a direct vendor of Great Lakes Technologies, LLC. Third party vendors such as garage sales, pawn shops, resale shops, or any other secondhand merchant void the warranty included with this product. Contact [techsupport@wenproducts.com](mailto:techsupport@wenproducts.com) or 1-800-232-1195 to make arrangements for repairs and transportation.

When returning a product for warranty service, the shipping charges must be prepaid by the purchaser. The product must be shipped in its original container (or an equivalent), properly packed to withstand the hazards of shipment. The product must be fully insured with a copy of the warranty card and/or the proof of purchase enclosed. There must also be a description of the problem in order to help our repairs department diagnose and fix the issue. Repairs will be made and the product will be returned and shipped back to the purchaser at no charge.

**THIS LIMITED WARRANTY DOES NOT APPLY TO ACCESSORY ITEMS THAT WEAR OUT FROM REGULAR USAGE OVER TIME INCLUDING BELTS, BRUSHES, BLADES, ETC.**

**ANY IMPLIED WARRANTIES SHALL BE LIMITED IN DURATION TO TWO (2) YEARS FROM DATE OF PURCHASE. SOME STATES IN THE U.S., SOME CANADIAN PROVINCES DO NOT ALLOW LIMITATIONS ON HOW LONG AN IMPLIED WARRANTY LASTS, SO THE ABOVE LIMITATION MAY NOT APPLY TO YOU.**

**IN NO EVENT SHALL SELLER BE LIABLE FOR ANY INCIDENTAL OR CONSEQUENTIAL DAMAGES (INCLUDING BUT NOT LIMITED TO LIABILITY FOR LOSS OF PROFITS) ARISING FROM THE SALE OR USE OF THIS PRODUCT. SOME STATES IN THE U.S. AND SOME CANADIAN PROVINCES DO NOT ALLOW THE EXCLUSION OR LIMITATION OF INCIDENTAL OR CONSEQUENTIAL DAMAGES, SO THE ABOVE LIMITATION OR EXCLUSION MAY NOT APPLY TO YOU.**

**THIS LIMITED WARRANTY GIVES YOU SPECIFIC LEGAL RIGHTS, AND YOU MAY ALSO HAVE OTHER RIGHTS WHICH VARY FROM STATE TO STATE IN THE U.S., PROVINCE TO PROVINCE IN CANADA AND FROM COUNTRY TO COUNTRY.**

**THIS LIMITED WARRANTY APPLIES ONLY TO PORTABLE ELECTRIC TOOLS, BENCH POWER TOOLS, OUTDOOR POWER EQUIPMENT AND PNEUMATIC TOOLS SOLD WITHIN THE UNITED STATES OF AMERICA, CANADA AND THE COMMONWEALTH OF PUERTO RICO. FOR WARRANTY COVERAGE WITHIN OTHER COUNTRIES, CONTACT THE WEN CUSTOMER SUPPORT LINE.**



**THANKS FOR REMEMBERING**

