

# Assembly Instructions

**Caution: You must read this before you proceed.**

## Table

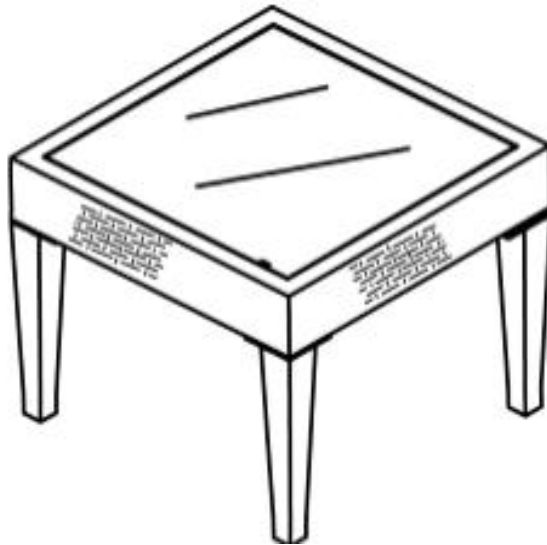

CAUTION : This Table is NOT a TOY.  
Keep your child / children at bay during the assembly process.

## Parts List

Label	Picture	Description	QTY
A		Table Top	1
B		Leg	4
C		Glass	1

## Hardware

Label	Picture	Description	QTY
①		Allen Key	1
②		Washer	13
③		Bolt (M6*15mm)	13

# Assembly Preparation

Before Beginning Assembly:

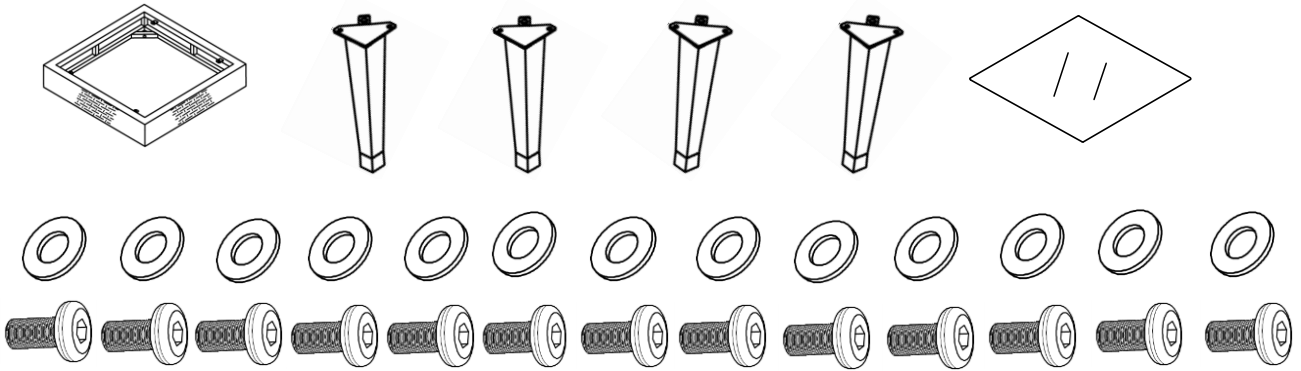

- Read instructions, cover to cover-



- Have 2 adults on hand for assembly-



- Do not assemble on flooring or carpet-



- Assemble on a clean non-marring surface (packing foam)-



- Save all packaging until finished-

# Assembly Steps

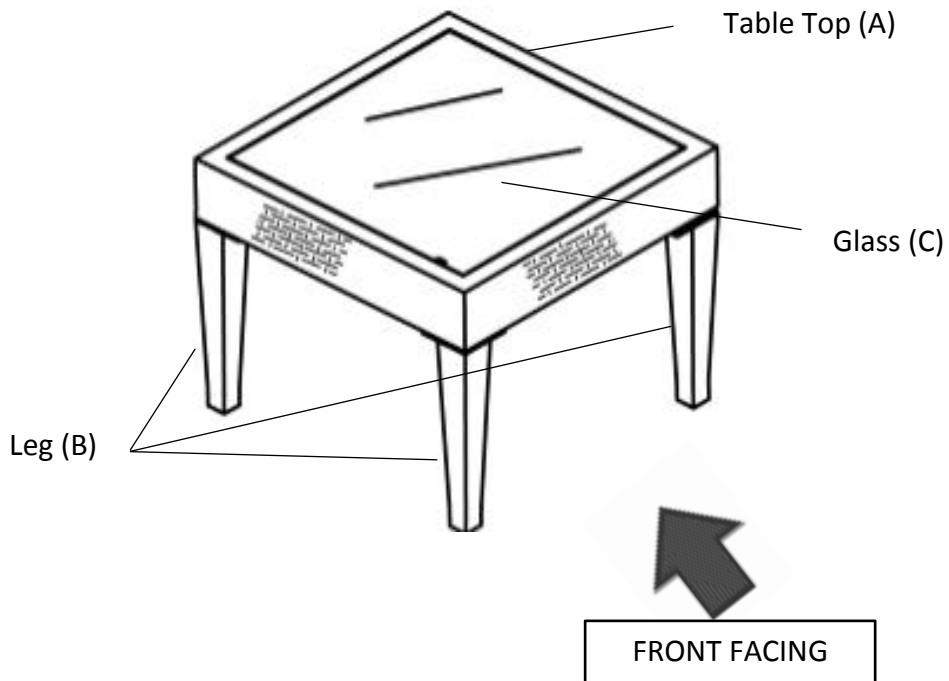

This Table has multiple parts and may require up to 30 minutes to assemble. To give you an overview of the Table parts, the above picture is to help you put the various parts into perspective. Please read through the instructions below to familiarise yourself with the parts and steps before assembly.

## Step 1

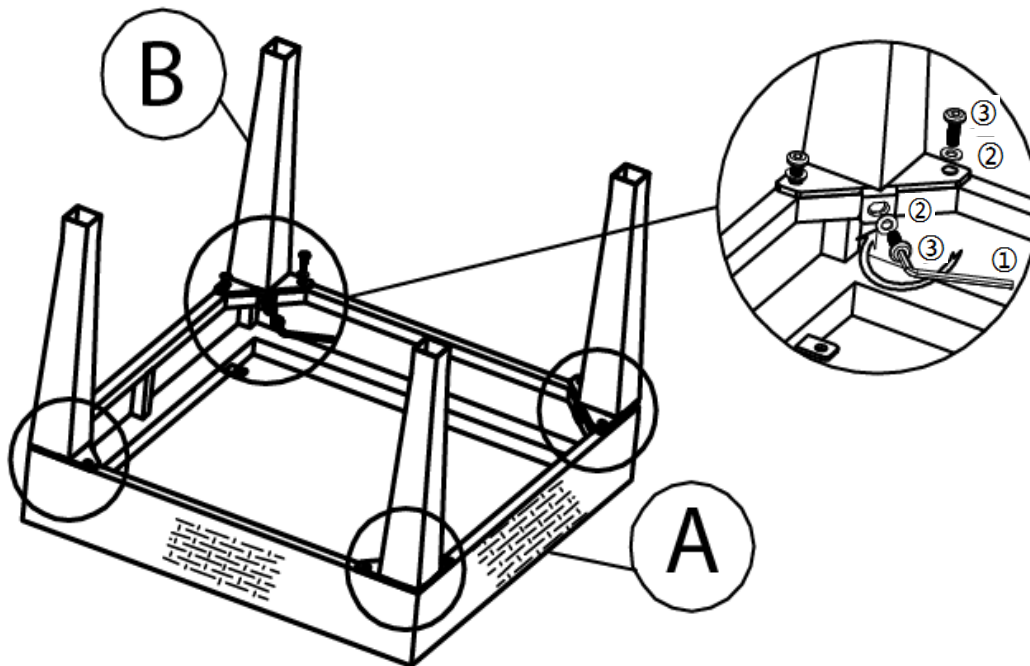

Open the carton and place all parts onto a clean, non-marring surface.

**It is recommended that you have a partner to assist with the assembly process.**

Turn the Table Top(A) face down on a clean, non-marring surface.

Attach Legs(B) to Table Top(A) using Bolts(③) and Washer(②) with Allen Key(①).

Repeat the same process to with the remaining Legs.

**Only loosely tighten the Bolts.**

## Step 2

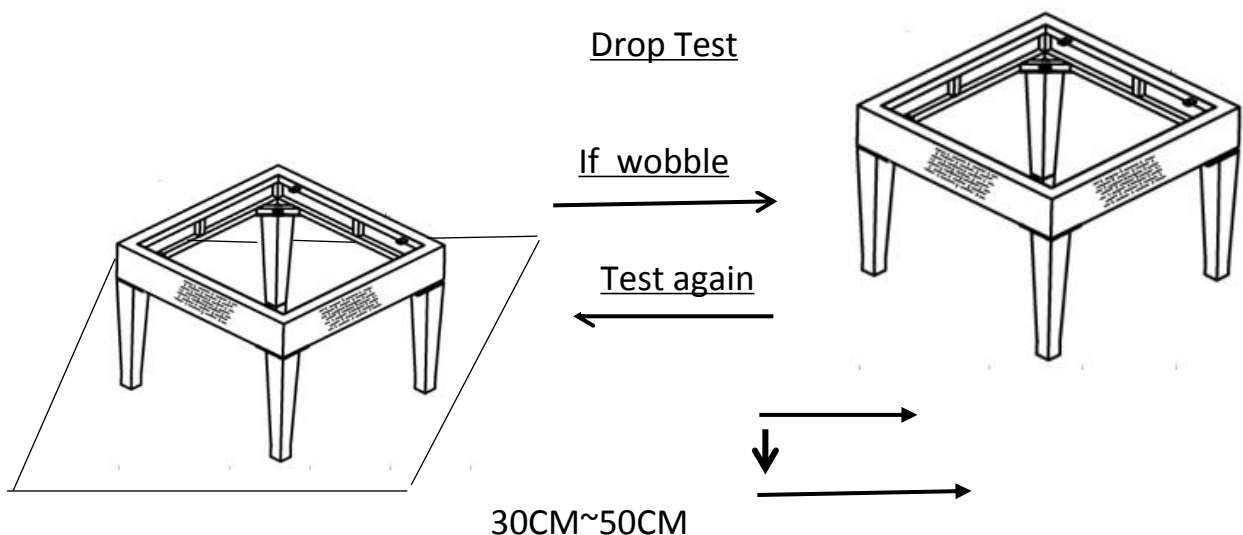

Turn this Table right way up. Place the table on a LEVEL SURFACE to check for wobbles. If it wobbles, lift the table to some 20cm to 30cm height from the ground. Keep your feet and toes well away from the drop zone. Drop the table freely and vertically with all four legs, hitting the ground, all at the same time. This Drop Test will help to ensure that all the Bolts and gaps all reach full alignment status. Test again for evenness on a LEVEL SURFACE. If no wobbles found, with assistance from 2 to 3 adult partners, slowly and steadily, turn the table facedown. Then, proceed to tighten all Bolts in a sequential manner.

**When tightening the Bolts, tighten sequentially.**

**DO NOT tighten any Bolt fully and then towards the next one.**

**This could cause the frame to warp. If there are still wobbles, loosen the Bolts and execute the same drop test.**

**If the Table is not stable, it could lead to damage to the product.**

### Step 3

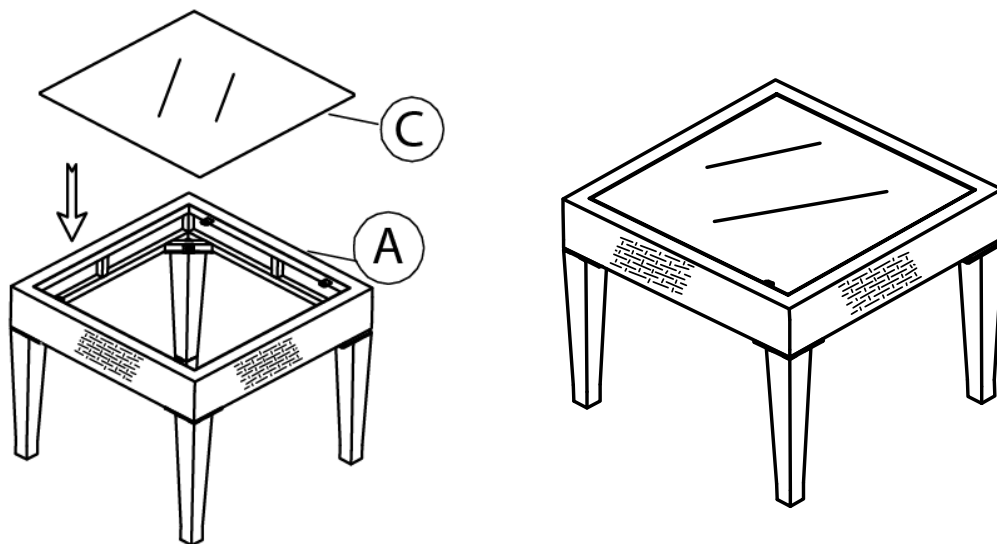





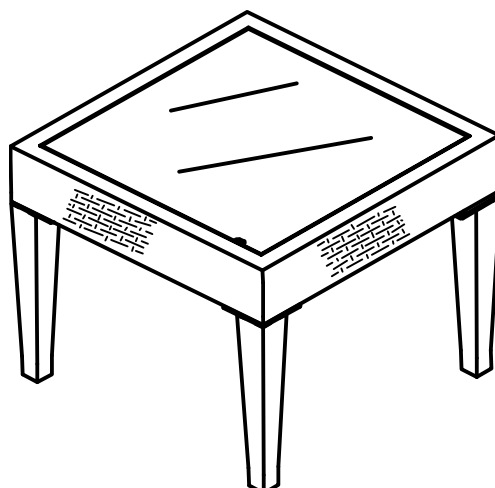















With the assistance of your adult partners, Carefully place the Glass(C) on the Table(A).  
**Do not place hands or fingers between the Glass and Table.**

### Step 4



Your Table is ready for use.  
This Table can only be used on a flat, level surface.

## Care & Maintenance

-   ● Do not put hot items directly on furniture surface.
  -   ● Do not clean furniture with harsh cleansers or polish.
  -   ● To obtain the longest lifespan of your outdoor products, minimizing exposure to direct sunlight is recommended.
  -   ● Children should not climb or jump on the furniture.
  -   ● Do not write on furniture without a padded barrier to protect the surface.
  -   ● To obtain the longest lifespan of your outdoor products, avoid extended and lengthy exposure to rain, snow, and direct sunshine. Whenever possible cover the product and /or place under patio or awnings.
  -   ● Not for commercial use. For residential use only.
  -   ● Stains may be removed with mild soap solution and damp cloth.
  -   ● Keep away from sources of ignition.
- 
-   ● Dust and pick-up spills using a clean, non-colored, lint-free cloth.

### What is Proposition 65?

Proposition 65 is a California law that requires warning labels on products that may contain one of more than 800-plus chemicals or ingredients that the California Office of Environmental Health Hazard Assessment (OEHHA) has deemed to cause cancer or other reproductive toxicity. Chemicals and elements on this list include wood dust, brass, and other everyday substances, which can be found in very common household items, such as: lamps, tableware, jewelry, crystal glasses, electric cords, beauty products, automobiles, and furniture.

### Why Did I Find a Proposition 65 Warning on My Home Goods Product?

We include Proposition 65 warnings on all of our products because there is always a chance that one of the 800-plus common chemicals and ingredients listed under this law could potentially be on our furniture or packing materials. We risk large fines under this law, if we don't include this warning.

### Should I worry?

We realize you may be worried finding this warning on our products, but we want to reassure you that the hazardous exposure limits for any of these chemicals have never been found on furniture products that we've shipped to our customers. Additionally, this warning label is very common and can be found on almost every piece of furniture sold in the state of California.

### Just How Common Are Proposition 65 Warnings?

Proposition 65 warnings have become so common in California that it is hard to take a trip to a local bank, grocery store, or restaurant without finding at least one warning. In fact, even the Disney Land Resort has a Proposition 65 warning:

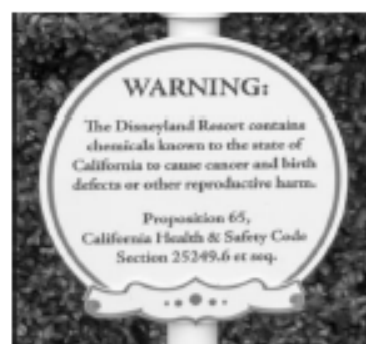



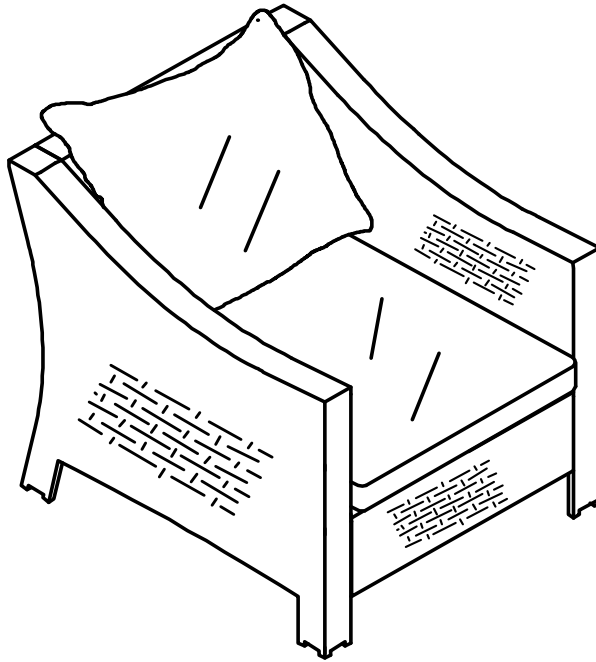

# Assembly Instructions

Caution: You must read this before you proceed

## Single Chair





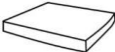



## Parts List

Label	Picture	Description	QTY
A		Right Armrest	1
B		Left Armrest	1
C		Chair Seat	1
D		Chair Back	1
E		Back Cushion	1
F		Seat Cushion	1

## Hardware





Label	Picture	Description	QTY
-------	---------	-------------	-----

①		Allen Key	1
②		Bolt (M6*30mm)	7
③		Bolt (M6*40mm)	6
④		Bolt (M6*95mm)	3
⑤		Washer	14
⑥		PE Cap	3

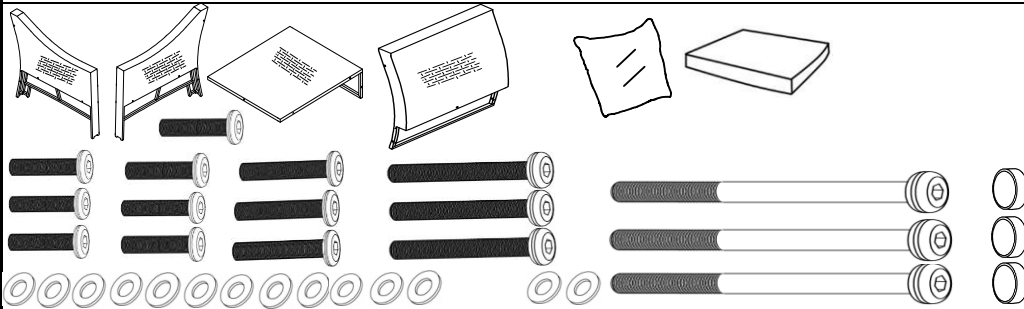
## Assembly Preparation

Before Beginning Assembly:



-  • Read instructions, cover to cover-
-  • Have 2 adults on hand for assembly-
-  • Do not assemble on flooring or carpet-
-  • Assemble on a clean non-marring surface (packing foam)-
-  • Save all packaging until finished-

## Assembly Steps

### OVERVIEW

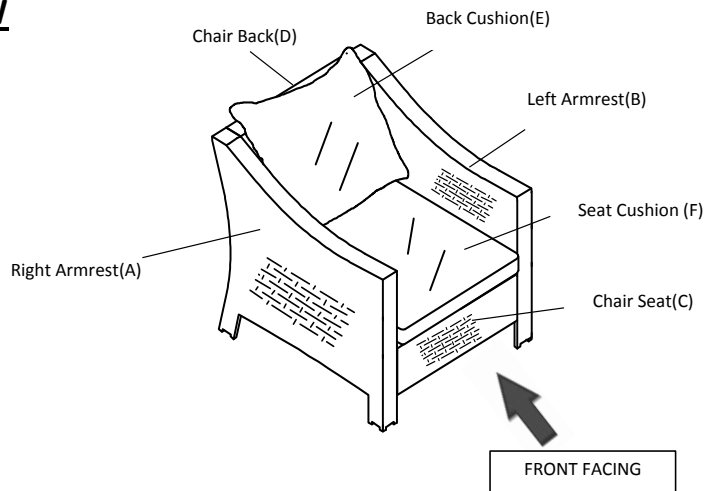

This Single Chair has multiple parts and may require up to 30 minutes to assemble. To give you an overview of the Single Chair parts, the above picture is to help you put the various parts into perspective. Please read through the instructions below to familiarise yourself with the parts and steps before assembly.

## Step 1

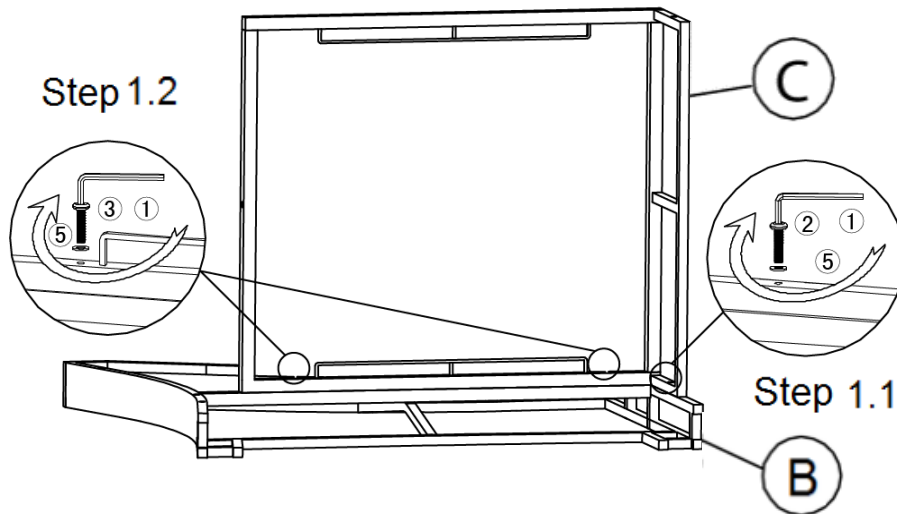

Open the carton and place all the parts onto a clean, non-marring surface.  
Place the Left Armrest(B) facing up.

**Step 1.1** Attach Chair Seat(C) to Left Armrest(B) using Bolt(②) and Washer(⑤) with Allen Key(①).

**Step 1.2** Attach Chair Seat(C) to Left Armrest(B) using Bolt(③) and Washer(⑤) with Allen Key(①).

**Only loosely tighten the Bolts.**

**ATTENTION:** There may be some PE wicker that may have covered the Bolt points.  
To ease assembly, guide and slide the PE wicker away from the mounting positions.  
**DO NOT CUT AWAY** any PE WICKER as this would cause the wicker to unravel!

## Step 2

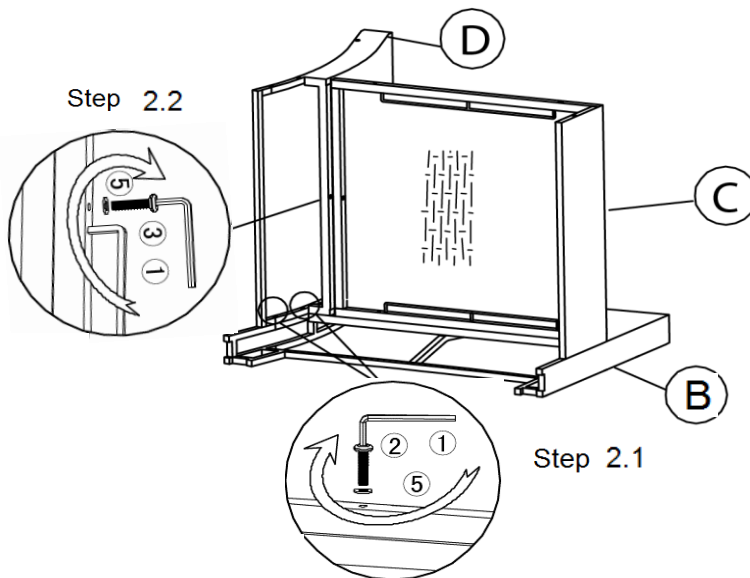

**Step 2.1** Attach Chair Back(D) to the Left Armrest(B) and Chair Seat(C) using Bolt(②) and Washer(⑤) with Allen Key(①).

**Step 2.2** Attach Chair Back(D) to the Left Armrest(B) and Chair Seat(C) using Bolt(③) and Washer(⑤) with Allen Key(①).

**Only loosely tighten the Bolts.**



### Step 3

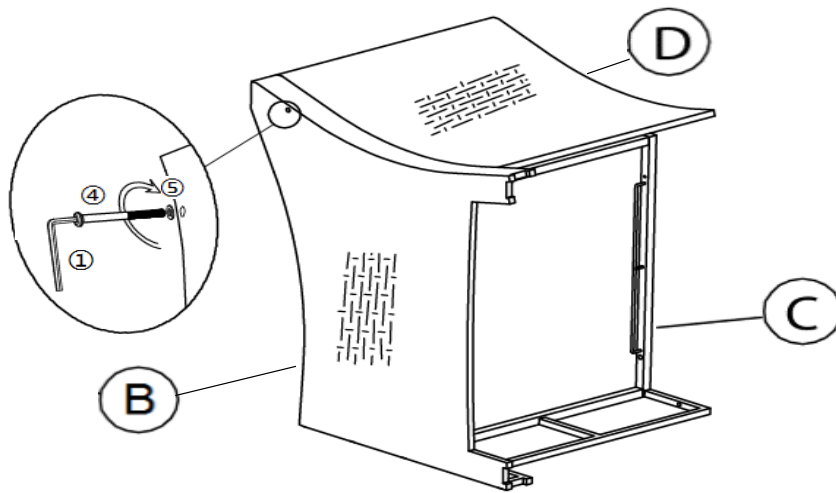

Place the Single Chair as shown in the picture above.  
Align the mounting positions of the Left Armrest(B) onto the Chair Back(D).  
Attach Left Armrest(B) and using Bolt(④) and Washer(⑤) with Allen Key(①).  
**Only loosely tighten the Bolts.**

### Step 4

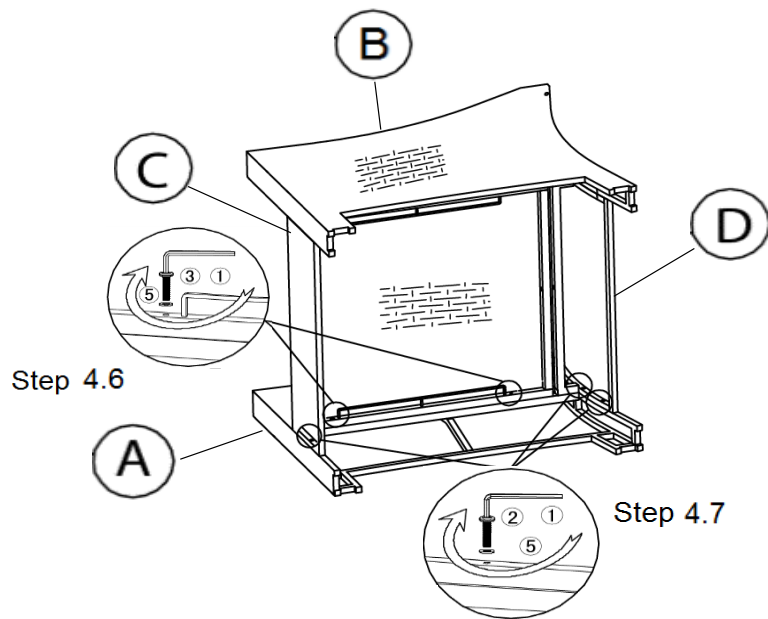

**Step 4.6)** Attach Right Armrest(A) to the Chair Seat(C) and Chair Back(D) using Bolt(③) and Washer(⑤) with Allen Key(①).  
**Step 4.7)** Attach Right Armrest(A) to the Chair Seat(C) and Chair Back(D) using Bolt(②) and Washer(⑤) with Allen Key(①).  
**Only loosely tighten the Bolts.**

## Step 5

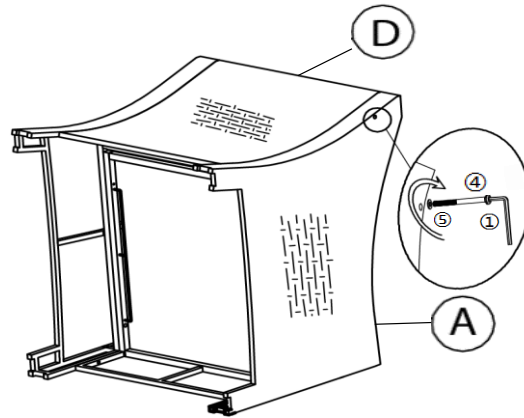

Place the Single Chair as shown in the picture above.

Align the mounting positions of the Right Armrest(A) onto the Chair Back(D).

Attach Right Armrest(A) and Chair Back(D) using Bolt(4) and Washer(5) with Allen Key(1).

**Only loosely tighten the Bolts.**

## Step 6

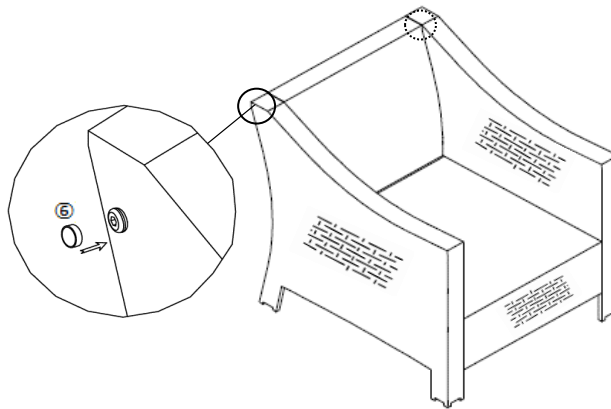

Turn the Single Chair right side up.

Place the Single Chair on a LEVEL SURFACE.

Inspect it and make sure all parts are adequately connected.

Gently sit on the Single Chair.

This will help to align all parts at all joints.

Then carefully get off the Single Chair, and in a sequential manner, proceed to tighten all Bolts.

**When tightening the Bolts, tighten sequentially.**

**DO NOT tighten any Bolt fully and then move on to the next one.**

**This may cause the frame to warp.**

**If there is still wobbles, loosen the bolts and execute this same process.**

**If the Single Chair is not stable it could lead to damage to the product.**

Place PE Caps(6) on Bolts as shown.



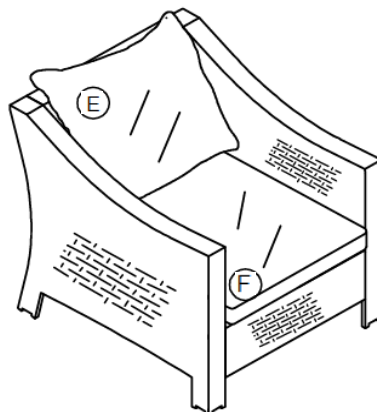

















## Step 7



Put the Seat Cushion(F) and Back Cushion(E) on the Single Chair.

Your Single Chair is ready for use.

## Care & Maintenance

-   • Do not put hot items directly on furniture surface.
  -   • Do not clean furniture with harsh cleansers or polish.
  -   • To obtain the longest lifespan of your outdoor products, minimizing exposure to direct sunlight is recommended.
  -   • Children should not climb or jump on the furniture.
  -   • Do not write on furniture without a padded barrier to protect the surface.
  -   • To obtain the longest lifespan of your outdoor products, avoid extended and lengthy exposure to rain, snow, and direct sunshine. Whenever possible cover the product and /or place under patio or awnings.
  -   • Not for commercial use. For residential use only.
  -   • Stains may be removed with mild soap solution and damp cloth.
  -   • Keep away from sources of ignition.
- 
-   • Dust and pick-up spills using a clean, non-colored, lint-free cloth.

### What is Proposition 65?

Proposition 65 is a California law that requires warning labels on products that may contain one of more than 800-plus chemicals or ingredients that the California Office of Environmental Health Hazard Assessment (OEHHA) has deemed to cause cancer or other reproductive toxicity. Chemicals and elements on this list include wood dust, brass, and other everyday substances, which can be found in very common household items, such as: lamps, tableware, jewelry, crystal glasses, electric cords, beauty products, automobiles, and furniture.

### Why Did I Find a Proposition 65 Warning on My Home Goods Product?

We include Proposition 65 warnings on all of our products because there is always a chance that one of the 800-plus common chemicals and ingredients listed under this law could potentially be on our furniture or packing materials. We risk large fines under this law, if we don't include this warning.

### Should I worry?

We realize you may be worried finding this warning on our products, but we want to reassure you that the hazardous exposure limits for any of these chemicals have never been found on furniture products that we've shipped to our customers. Additionally, this warning label is very common and can be found on almost every piece of furniture sold in the state of California.

### Just How Common Are Proposition 65 Warnings?

Proposition 65 warnings have become so common in California that it is hard to take a trip to a local bank, grocery store, or restaurant without finding at least one warning. In fact, even the Disney Land Resort has a Proposition 65 warning:

