

CAROLINA CHAIR & TABLE COMPANY

ASSEMBLY INSTRUCTIONS





Item # 4235





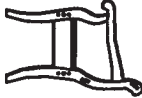

Veranda Storage Bench



Thank you for purchasing a Carolina Chair & Table Company product. This product has been designed for easy assembly and is constructed for durability. Please take the time to read and follow the assembly instructions carefully. If a part or hardware is missing or you have any difficulties in assembling this product, Please contact us Toll-Free at 1-800-228-3876

Read instructions carefully and remove all parts from the carton.
 See hardware and parts list guide.
 Be sure you have all parts before you start assembly.
 Place all wooden parts on a clean, soft surface.

PARTS LIST			
A		Armrest Frame	2PCS
B		Back Panel	1PC
C		Apron	1PC
D		Seat Board	1PC
E		Bottom Panel	1PC

HARDWARE LIST			
F		Allen Head Bolts	8PCS
G		Wood Plugs	16PCS
H		Metal Connector	1PC
I		Screws	8PCS
J		Wood Covers	8PCS
K		Glue	1PC
L		Allen Head Wrench	1PC

STEP 1

Add Glue (K) to wood plug holes and insert wood plugs (G) as shown. Connect Back Panel (B), Seat Board (D) with back Apron and the front Apron (C) to Armrest Frame (A), fasten them with Allen Head Bolts (F).

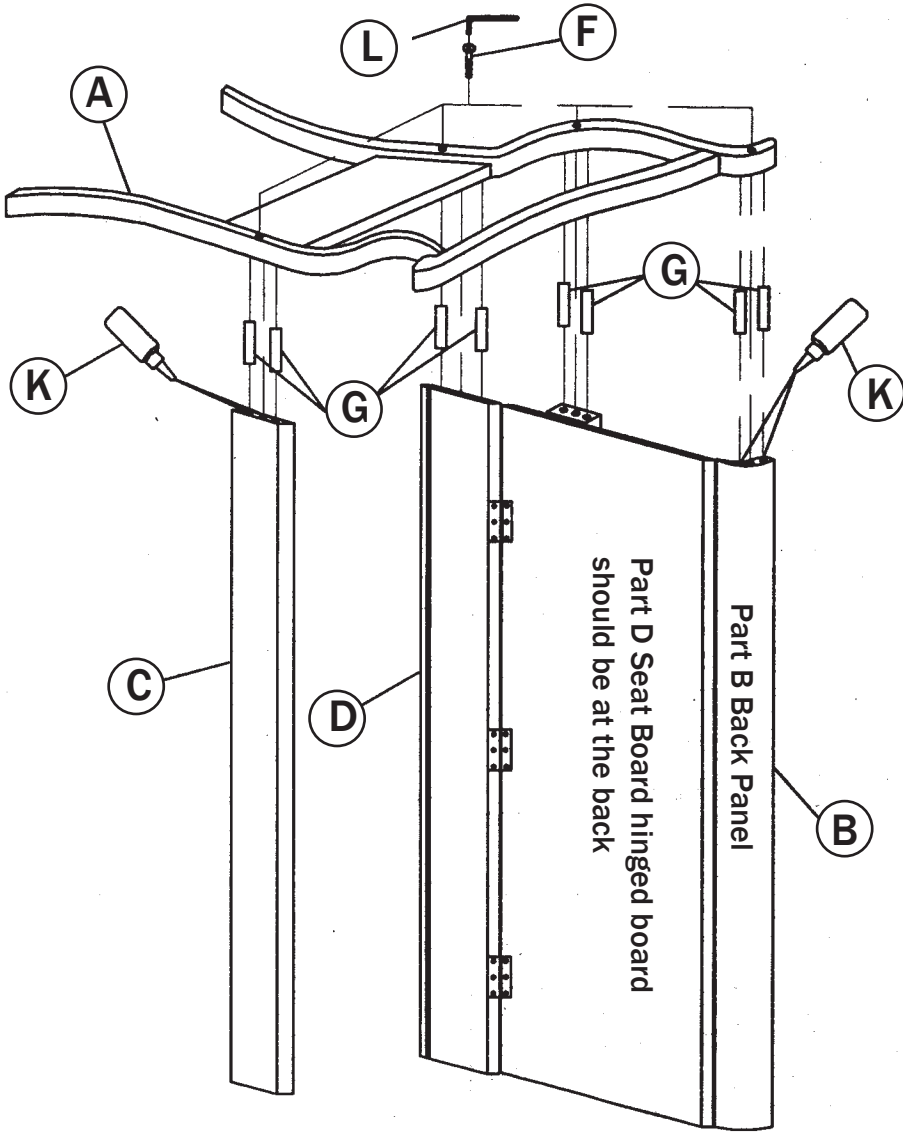

STEP 2

Insert the thin Bottom Panel (E) into groove inside the Aprons, connect Back Panel (B), Seat Board (D) with back Apron and the front Apron (C) to Armrest just like other side.

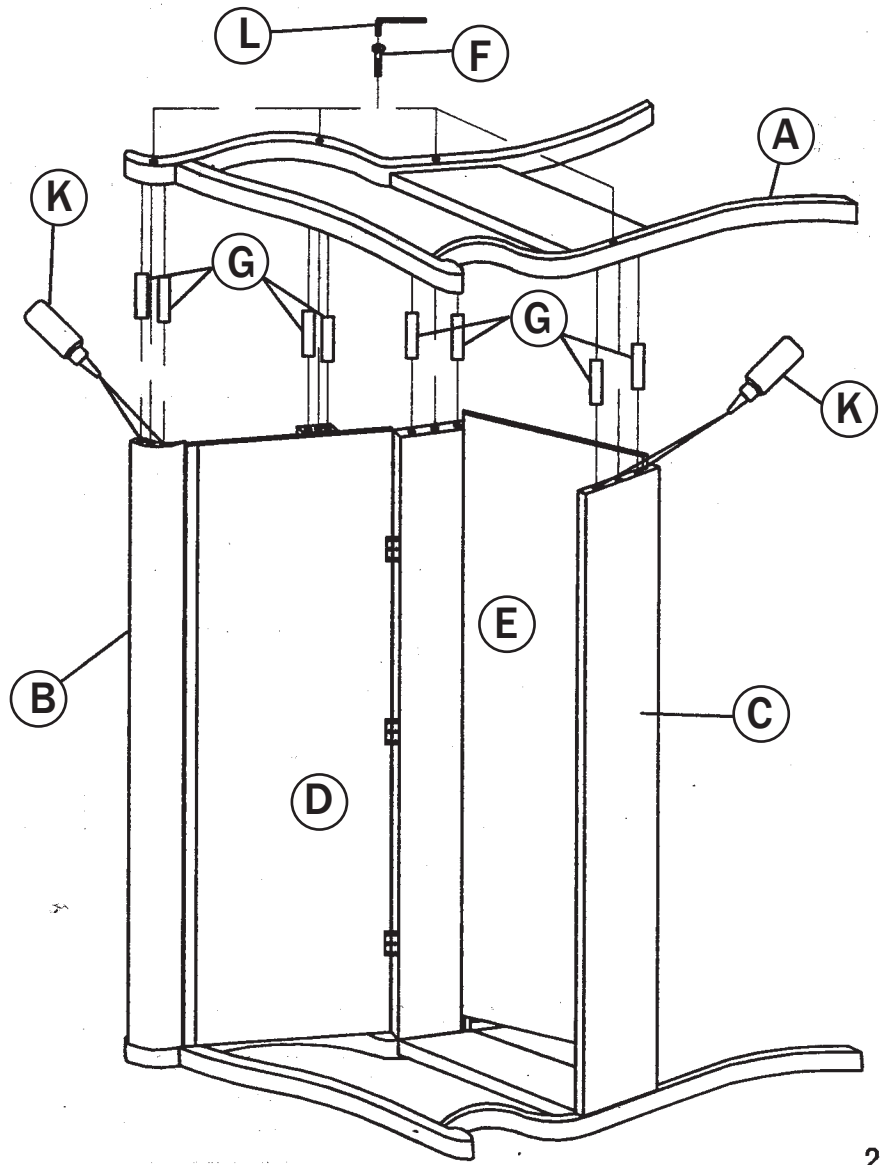

STEP
3

After checking the screw holes carefully on the back side of Seat Board and the back Apron, assemble the Metal Connector (H) vertically to Seat Board (D) and the back Apron inside the storage box with Screw (I) as shown.

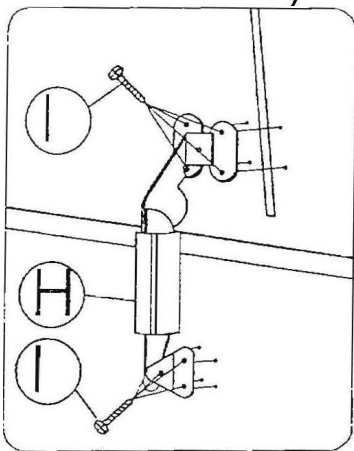
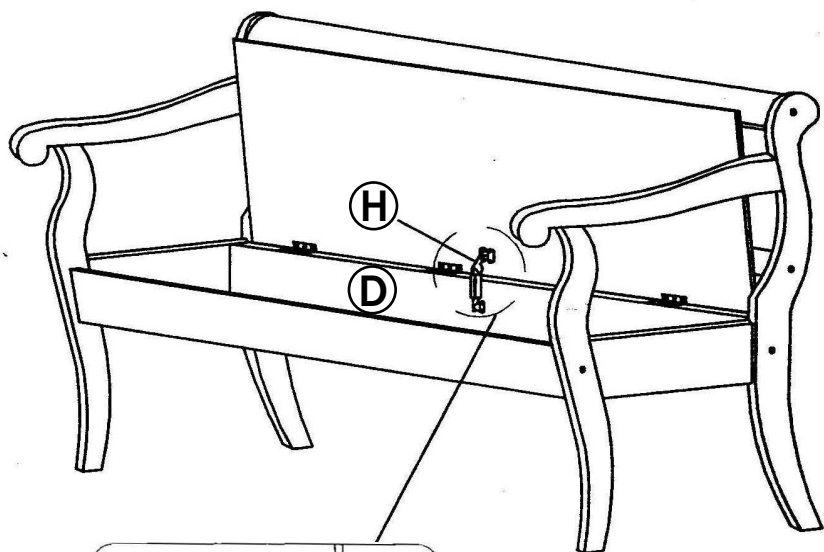

STEP
4

Cover the screw holes with the Wood Covers (J).

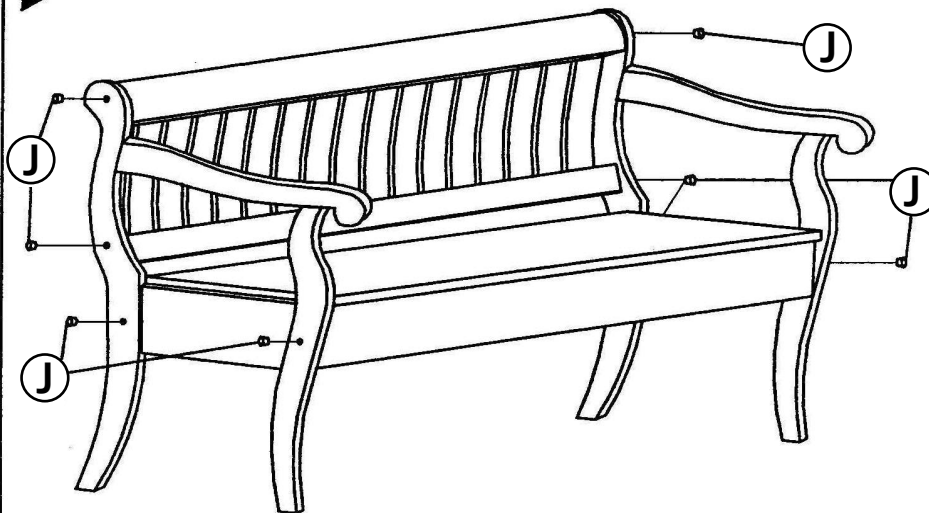

STEP
5

Finished product.

