

USER'S MANUAL

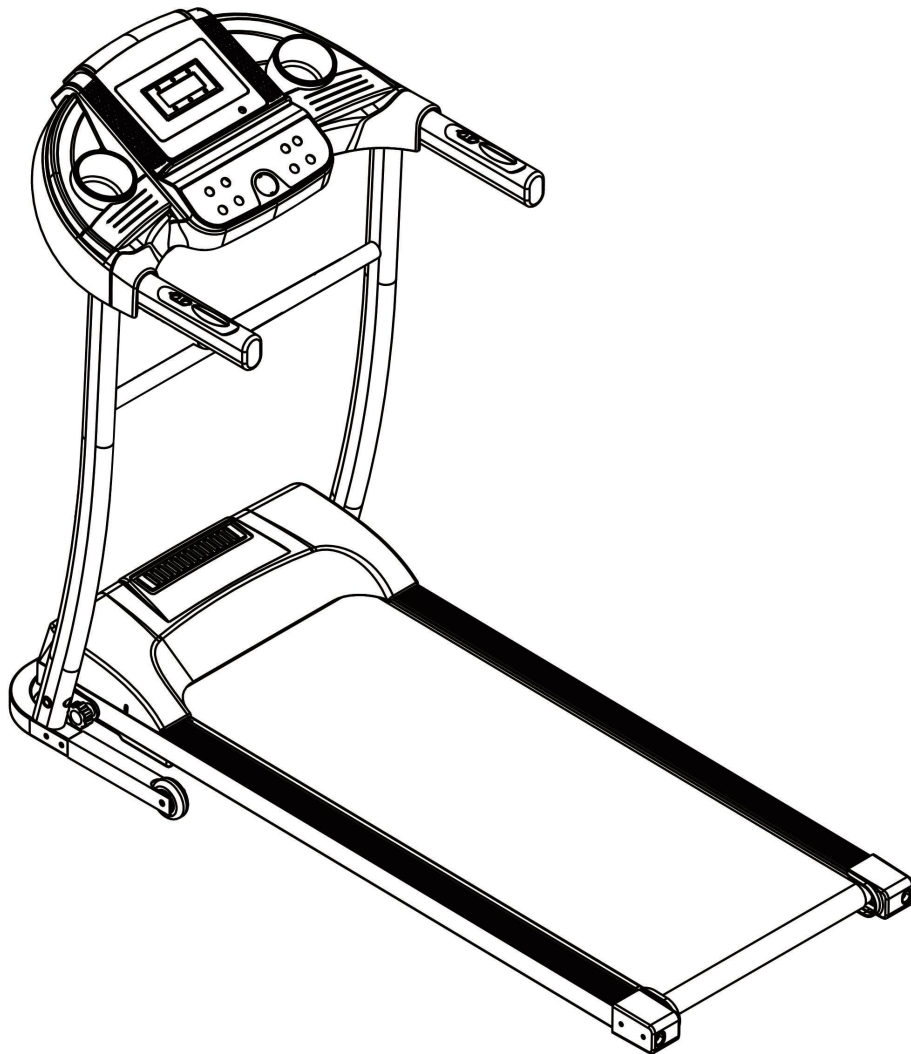

Note: Following the principles of sustainable development, we may modify machines when necessary and will not notice again. It all depends on the actual product.

Contents

Product Brief	2
Security Precautions and Warnings	4
Installation Instructions	7
Using Instructions	10
Routine Maintenance	14

1. Product Brief

Product name: Merax L510C Folding Electric Treadmill Motorized Running Machine

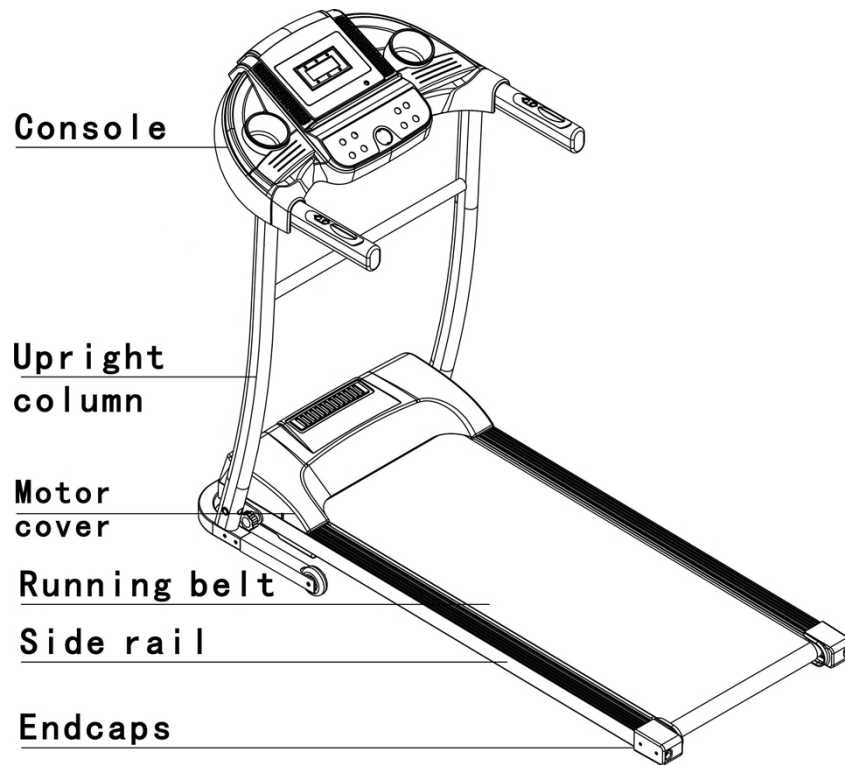

Main parameters and parts list

Main technical parameters

No.	Parameters Names	Description
1	Input power voltage	110V
2	Motor power	1.5 HP
3	Speed	0.8-12 Km/h
4	Running surface	400*1100 mm
5	Max user weight	240 LBS
6	Expand dimensions	1430*635*1065mm

Packing list

No.	Name	units	Qty
1	Complete machine	set	1
2	Accessory Bag	pc	1

Accessory bag list

NO.	Name	QTY	NO.	Name	QTY
1	Inner hexagon spanner 5mm	1	6	User's Manual	1
2	Inner hexagon spanner 6mm	1	7	MP3 cable	1
3	Combination wrench	1	8	Screw M8*22	2
4	Safety key	1	9	Screw M6*12	4
5	Silicone oil	1			

2. Security Precautions and Warnings

Tips: Before folding the treadmill, make sure that the gradient is "zero".

Notice: Please read the instructions carefully before use.

- ◆ The treadmill is for indoor use and storage only. Avoid dampness and water spills.
- ◆ Please wear suitable clothes and sneakers before exercise. Prohibited to exercise on the treadmill barefoot.
- ◆ High power plug must be grounded, electric outlet should have a dedicated circuit, do not share with other electrical equipment.
- ◆ Keep children away from the machine to avoid accidents.
- ◆ Avoid using the machine for a long time at a stretch and overload operation, otherwise it will cause damage to the motor and controller, and will accelerate the deterioration of the bearing, running belt and running board. Maintenance of the machine must be done on a regular basis.
- ◆ Keep machine away from dust to avoid strong static.
- ◆ Please switch off the electric power after using.
- ◆ Please maintain good ventilation when running.
- ◆ Please clamp security lock cable on your clothing to make sure the machine stops in any emergency condition.
- ◆ If you do not feel well while using this machine, please stop and consult a doctor.
- ◆ Silicone oil must be kept away from children after use.
- ◆ If power cord is damaged, please contact our qualified maintenance personnel for service rather than disassemble it at your own discretion.



Forbidden

- ◆ Don't use the machine in the status of the shell break in or break off (the internal structure exposed) or under the condition of welding-parts may fall off.
---- Otherwise an accident or injury may occur.
- ◆ Don't jump up and down in the process of movement.
---- Injuries may be caused by the fall.
- ◆ Don't keep machine in or near moist space such as the bathroom.
- ◆ Don't place machine in direct sunlight, or high temperature places such as near a stove or a

heating appliance.

----Otherwise it may cause leakage and burst into flames.

- ◆ Don't use when the power cord is damaged or power plug pin is loose.
----Otherwise it will lead to an electric shock, short circuit or fire.
- ◆ Don't damage or bend by force or reverse the power cord. Don't place heavy objects on machine, don't clamp the power line.
----Otherwise it will cause fire or get an electric shock.
- ◆ Don't use machine for more than 2 people at the same time, and don't get close to the machine when it is in use.
---- Or it may cause an accident or injury due to falls.
- ◆ People who can't express their consciousness or can't operate the machine by themselves cannot use the treadmill.
----May lead to accident or injury.
Avoid drinking water or pouring water when treadmill is in operation.
---- May cause electric shock and fire. Forbidden!
- ◆ People who seldom exercise are advised not to suddenly do any intensive workout.
- ◆ Do not use machine, directly after a meal or when feeling tired.
---- This may lead to you damaging your health.
- ◆ This product is suitable for family use. Does not apply to schools, gymnasium and so on.
---- There is the danger of injury.
- ◆ Don't use when hard objects are in the pockets of your pants or shorts. Kindly remove them before using the machine.
----May cause accident or injury.
- ◆ Don't use when the power plug is on the needle, garbage, or water.
----May cause electric shock, short circuit, or fire. Do not use with wet hands!
- ◆ When not in use, pull out the power plug from the socket.
----The dust and moisture can age the insulation, and result in leakage fire.
- ◆ This appliance is not intended for use by persons (including children) with reduced physical, sensory or mental capabilities, or lack of experience and knowledge, unless they have been given supervision or instruction concerning use of the appliance by a person responsible for

their safety.

- ◆ Children should be supervised to ensure that they do not play with the appliance.









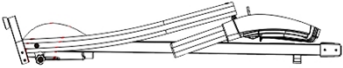

Ground protection system!

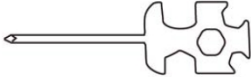
- ◆ This product must be grounded. If the machine is dysfunctional, grounding will provide a good channel for electric current, in order to reduce the electric shock risk.
- ◆ This product is equipped with power plug with grounding conductor and plug. Completely insert the plug to standard socket.
- ◆ If the equipment grounding conductor's connection is improper, it will cause electric shock. If you have any doubt about whether your product is grounded correctly or not, please entrust professional to check.
- ◆ Please use the socket which has the same shape with the grounding plug. Don't use plug adapter.

3.Installation Instructions

When installing, simple fix all screws first, then tighten the screws when the installation of frame is done.

NO.	Name	QTY	
1	Complete Machine	1PC	
2	6mm inner hexagon wrench	1PC	
3	5mm inner hexagon wrench	1PC	
4	Combination wrench	1PC	
5	Safety key	1PC	
6	Silicon oil	1PC	
7	MP3 cable	1PC	
8	Screw M8*22	2PCS	

9	Screw M6*12	4PCS	
12	User's manual	1PC	

1. Put the machine flat on the ground. Remove the knob with the direction shown in the picture bellow. Then stand the upright columns and console with the direction shown in the picture bellow.

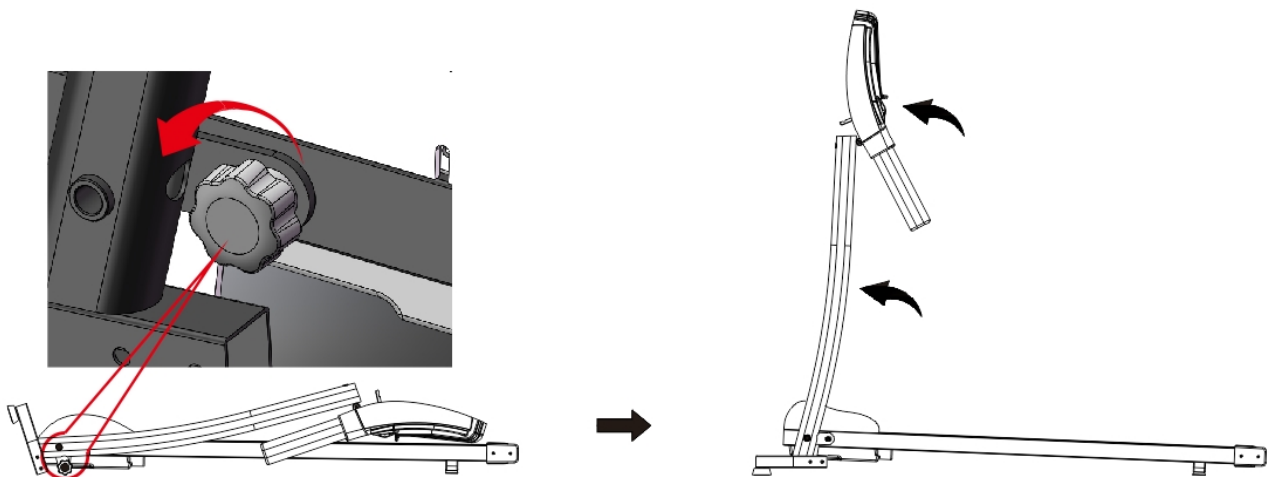

2. Use 5# hexagon wrench and screw M6*12 to lock and fix the base(two screws for each side). Then assemble screw M8*22 with the direction shown on the left picture bellow(both sides).

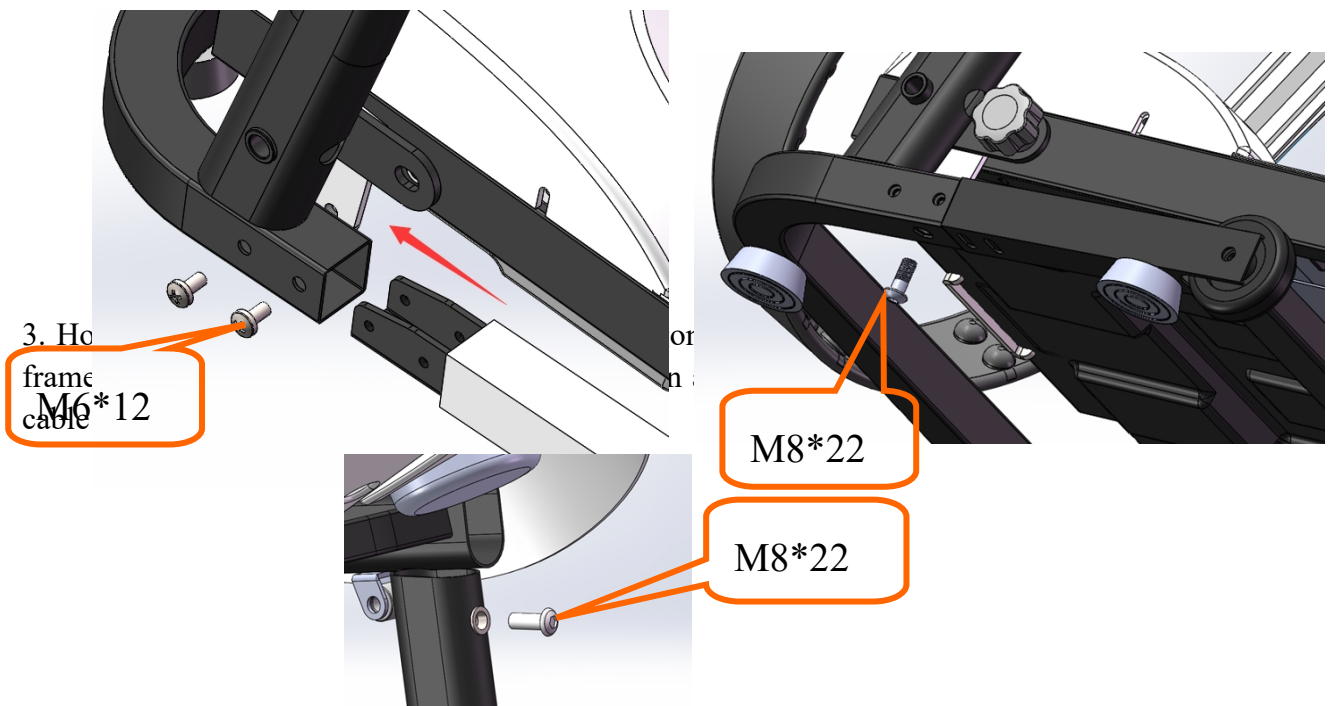

4. Use the knob in step one to lock the main base and columns(rotate clockwise, please refer to the picture bellow). Uneven ground may cause trouble when rotate the knob, please lift the column slightly to the

left side(as shown in the picture bellow).In order to fold the machine easily next time, please don't rotate the knob too tightly.

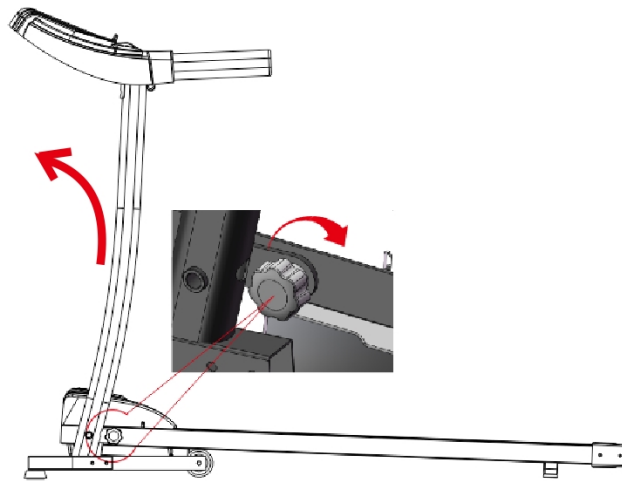

5.Put the safety key on the yellow part of the console (as shown in the picture bellow), then press the start button to start the treadmill.(Notice: The treadmill only starts when the safety key is put on the yellow area on the console.)

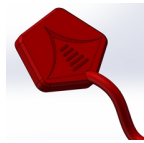
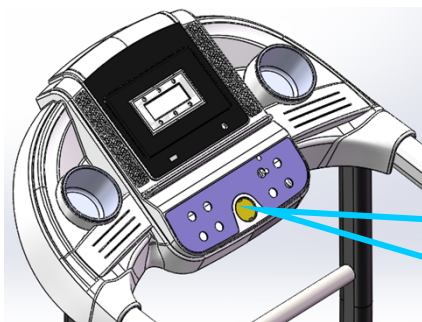

Safety key is in red color. Please find it in the accessory bag.

NOTE: please confirm that all screws are locked uniformly according to the requirements after installation, and check no part is left out before plugging electricity.

Folding instructions

When the treadmill is not in use, you can lift the running deck and them use knob to lock the

running deck and base, as shown in the picture bellow.

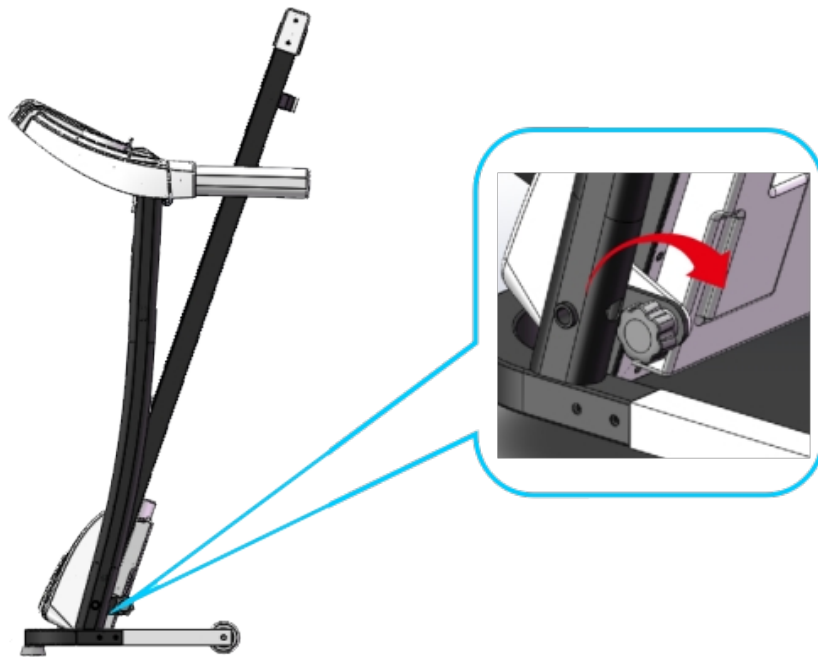

4. Using Instructions

Using treadmill

1. Insert the power plug properly and turn on the switch(in red color)(1). When the light is on, there will be a sound of “Di”, and then the screen will be light up.

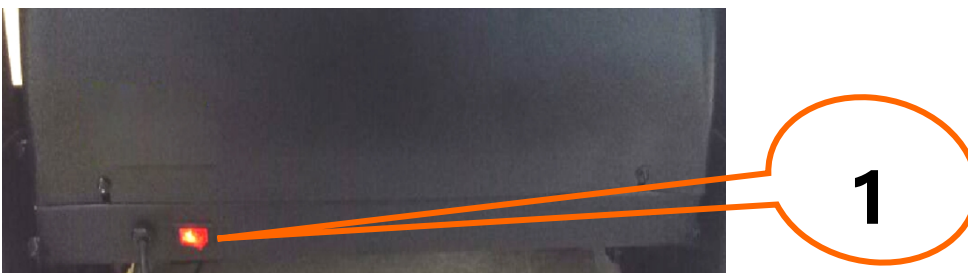

2. Please keep the safety key away from children when the treadmill is not in use. Please put the silicon oil bottle in places where children cannot reach. If it is eaten or split into eyes by mistake, please use running water to wash and consult doctor immediately.

3. Safety key Introduction

The treadmill can only start when the safety key is put on the yellow area on the console. Clip the safety key on clothes when using the treadmill to prevent accidents. Put the safety key back when continue using the treadmill.

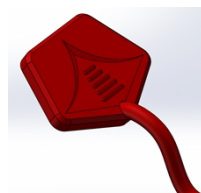

Console instructions

Sticker:

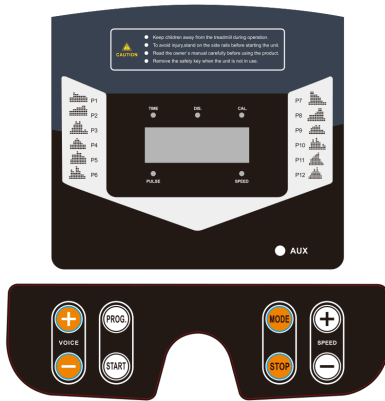

Button instructions

Start up Normally starts after 3 seconds of countdown.

Programs and modes 3 modes and 12 automatic programs.

Safety key function

Disconnect the safety key, "E7" shows on the screen. The treadmill stops gradually, and an alarm sound will be let out. Put the safety key back, all the data will be cleared in 2 seconds.

Under any circumstances, the treadmill will stop when disconnect the safety key. There will be prompt information on the screen. Put the safety key back, data on the screen will be back to the initial value.

Key function



1. Start button, Stop button:

When the power is on, press the start button, the screen displays "0.8 km/h", and the treadmill starts. When the treadmill is in running state, press the stop button, all data will be cleared, and the treadmill gradually comes into a complete stop and returns to the manual mode. Quick keys on the handle grips can be used to start or stop the treadmill, too.



2. Program key

In standby mode, pressing this key can cycle the options from manual mode to P1 to P12 automatic programs. The default speed of manual mode is 0.8 Km/h, the highest speed is 12 Km/h.



3. Mode key

In standby mode, press this key to cycle the options of 3 different countdown running mode: time countdown running mode, distance countdown running mode and calorie countdown running mode.

H-1: Time countdown mode. Default time value: 15 minutes. Time value can be set from 5:00-99:00.

H-2: Distance countdown mode. Default value: 1 km. Distance value can be set from 1-99km.

H-3: Calorie countdown mode. Default value: 50Kcal. Calorie value can be set from 10-999Kcal.

4. Volume \pm key



When connect with mobile phone, press “+” to turn the volume up and press “-” to turn the volume down.



5. Speed \pm key

Use these keys to adjust the speed of the treadmill by 0.1Km/press, press “+” to increase the speed and “-” to decrease the speed. Speed quick keys on the handle grips can be used to set speed values, too.

Display Function

1. Speed Display.

Display the current running speed value.

2. Time Display

Display the time of manual mode and the countdown time under automatic modes and programs.

3. Distance display

Display cumulative distance under manual mode and programs. Display the distance countdown in automatic mode.

4. Calorie display

Display cumulative calorie under manual mode and programs. Display the calorie countdown in automatic mode.

5. Heart rate display

Heart rate value will be shown when the signal is detected.

Automatic program

Each program is divided into 10 segments, and the running time of each segment of the program is evenly distributed. Users can change the time value by pressing speed buttons.

Code Meaning of error messages

Fault code	Failure Description	fault handling
E1	Communication Abnormal: when the power is on, the connection between lower controller and the console is abnormal.	<p>Possible Cause:</p> <p>The communication between console and lower controller is blocked, check each wire which connects the console with the lower controller, make sure that each core is fully plugged in.</p> <p>Check the cable of console and lower controller, replace it if it's broken.</p>
E2	No signal of motor	<p>Possible Cause:</p> <p>Check the motor cable to see whether it is connected well or not, if not, connect the motor wire again.</p> <p>Check the motor cable to see whether it is damaged or has a burnt smell, if yes, replace the motor.</p>
E5	Over current protection: When working , the lower controller detects the current to be over 6A for more than 3 seconds.	<p>Possible Cause:</p> <p>Overloading leads to excessive current, and the system stops out of self-protection, or some part is stuck, causing the motor to stop. Adjust the treadmill and restart it. Check if there is liquid or burnt smell while the motor is running, if yes, replace the motor; check if the controller has a burnt smell, if yes, replace the controller; check the power supply voltage, if it does not match the specifications, change into correct voltage and test the machine again.</p>
E6	Explosion-proof impact protection: the abnormal of voltage or motor cause the faulty of motor circuit.	<p>Possible Cause:</p> <p>Check if the power supply voltage is 50% lower than normal voltage, use the correct voltage and test the machine again; check if the controller has a burnt smell, if yes, replace the controller; Check if the motor cable is connected or not, and connect the motor wire if it's not well connected.</p>
E7	No safety key	Put the safety key on the right position on the console.

5. Routine maintenance

Warning: Before cleaning or maintaining products, please ensure that the power plug of the

treadmill is pulled out.

Cleaning: Comprehensive cleaning will extend the using life of the electric treadmill.

Remove dust periodically in order to keep the parts clean. Be sure to clean running belt with both sides of the exposed portion. This will reduce the accumulation of impurities. Kindly wear clean athletic shoes to avoid carrying any dirt into running board and belt. Treadmill belts must be cleaned by a damp cloth with soap. Please pay attention to avoid wetting the electrical components and running belt.

Warning: Ensure that the power plug is disconnected before removing motor cover. Clean the motor at least once a year.

Running belt specialized lubricant

This electric treadmill's running board and running belt has been lubricated before sale. Friction between the running belt and running board has a great influence on the life and the performance of the electric treadmill, therefore regular application of lubricant is needed. We advise you to check the board regularly. If the board's surface is damaged, please contact our customer service center.

We advise using the lubricant between running belt and running board with following schedule:

Lightweight user (use less than 3 hours a week) once per month;

Heavyweight user (use more than 7 hours a week) once every half month.

1. In order to better safeguard your electric treadmill and extend the life of the machine, it is recommended that after your continued use of two hours, turn off the machine and let it rest for 10 minutes before using again.

2. If the treadmill belt is too loose, there will be skid phenomenon while running; if it's too tight, it may reduce motor performance and harden the abrasion of roller and the running belt. You can lift two sides of the running belt for 50-75mm when the tightness is appropriate.

Running with adjusted alignment and tightness

In order to better use the treadmill and make the treadmill functions work better, it is necessary for you to adjust the running belt into the best condition.

Running Belt alignment

- Put electric treadmill flat on the ground.
- Make the electric treadmill run at a speed of about 6-8 km/hour.
- If the running belt is closer to the right, rotate the right adjusting bolt with 1/2 turn clockwise, then rotate the left adjusting bolt with 1/2 turn counter-clockwise. (Picture A)
- If the running belt is closer to the left, rotate the left adjusting bolt with 1/2 turn clockwise, then rotate the right adjusting bolt with 1/2 turn counter-clockwise. (Picture B)



Picture A

Picture B

Applying silicone oil

Step 1: Lift the running belt slightly.

Step 2: Open the silicone oil bottle, squeeze the silicone oil on the sides of running board, as shown

in the following picture:

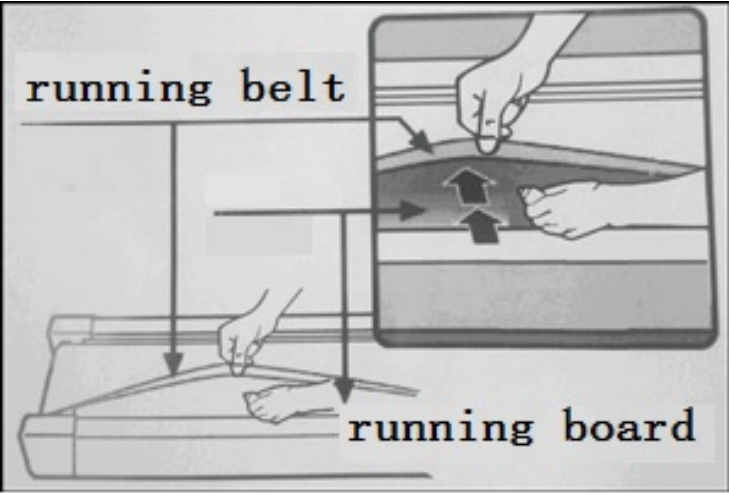

NOTE: If you have any questions about the product, please contact us at csr@merax.com.