

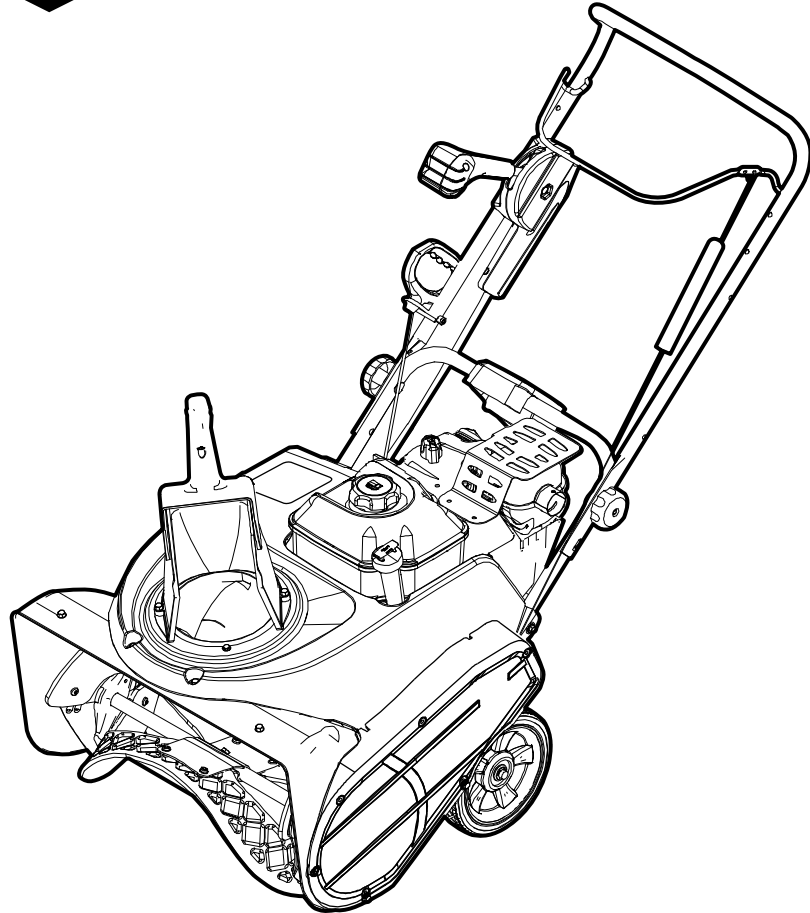

Parts Manual



Single Stage Snowthrower

Snowthrowers

Mfg. No.	Description
1696506-00	922EXD, B&S 9.0 Gross TP 22" Single Stage Snowthrower (2015)
1696506-01	922EXD, B&S 9.0 Gross TP 22" Single Stage Snowthrower (2016)

Manual Part No. 1759054

Revision A

Rev. Date: 11/11/2015

Not for
Reproduction

PRODUCT COMPONENTS	PAGES
Frame Group	4
Engine Group	6
Auger Drive Group	8
Handles & Controls Group - Remote	10
Wheel & Body Covering Group	12
Wheel & Body Covering Group	14
Decals Group	16
Chute Rotation Group - Remote	18
Chute Group - Remote	20
Auger Group	22
Chute Group - Remote	24
Chute Rotation Group - Remote (After Serial Number 2017172524)	26
Chute Rotation Group - Remote (Before Serial Number 2017158768)	28
Torque Specification Chart	Inside Back Cover

Not for
Reproduction

Frame Group

NOTE: Unless noted otherwise, use the standard hardware torque specification chart.

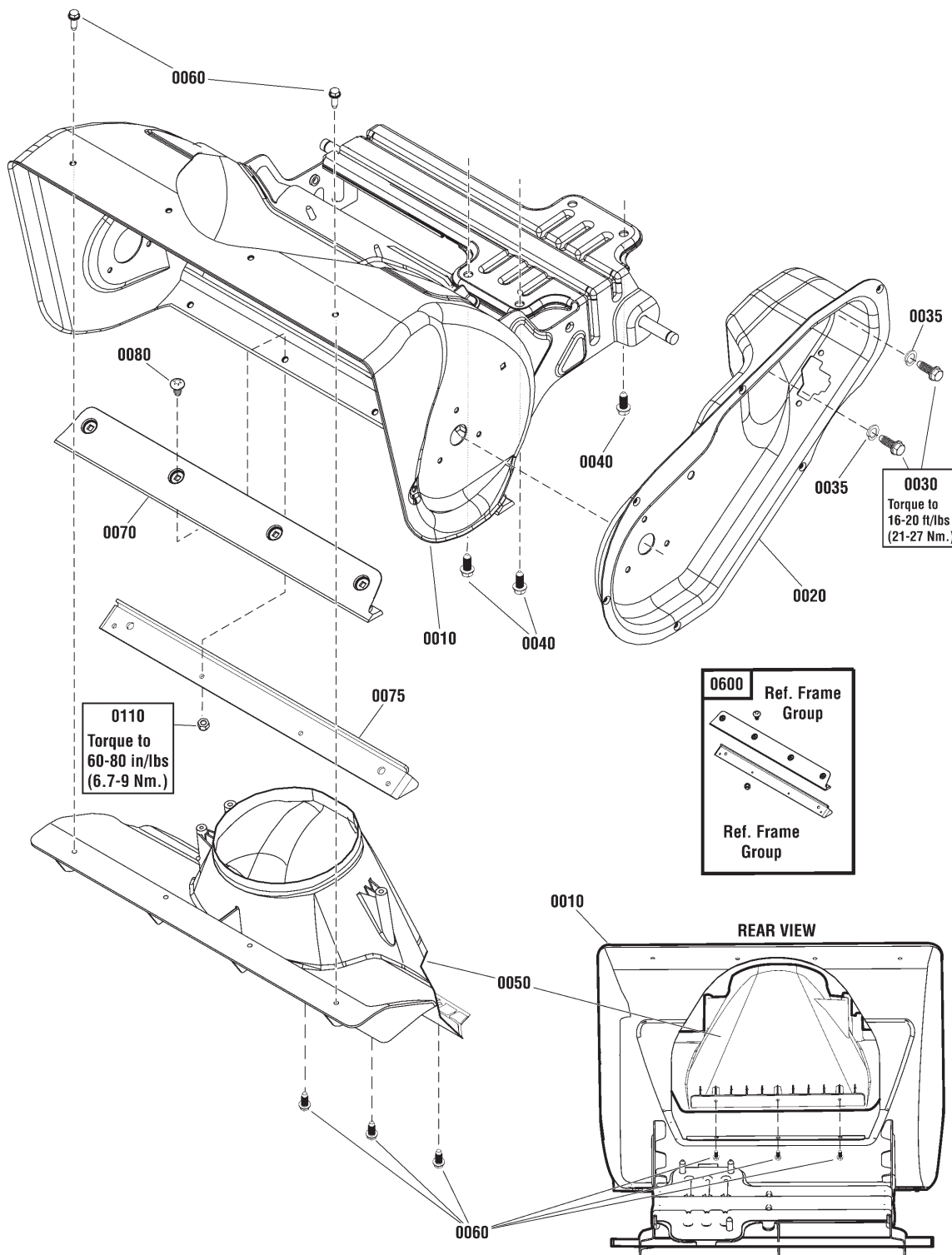

The above parts group applies to the following Mfg. Nos.:

- 1696506-00 - 922EXD
- 1696506-01 - 922EXD

Frame Group

REF NO	PART NO.	QTY.	DESCRIPTION
0010	1756280AYP	1	FRAME ASSEMBLY
0020	1739100BMYP	1	HOUSING, Drive
0030	1752876YP	2	CAPSCREW, Hex Head, 5/16-24 x 5/8
0035	703116	2	WASHER, Lock, 5/16
0040	75246GS	3	SCREW, Hex Washer Head, Taptite, 3/8-16 x 1-1/4
0050	1739555YP	1	CHIMNEY (Used before Serial No. 2017125703)
0050	707849	1	CHIMNEY (Used after Serial No. 2017125704)
0060	7091081SM	5	CAPSCREW, Hex Washer, Hi-Low, 1/4-15 x 3/4
0070	-----	1	SCRAPER BAR (Included with Ref. No. 0600)
0075	1752660BMYP	1	SUPPORT, Scraper Blade (Included with Ref. No. 0600)
0080	5025299X5YP	4	SCREW, Allen Head, 1/4-20 x 5/8 (Included with Ref. No. 0600)
0110	1752935YP	4	NUT, Hex Lock, Nylon, 1/4-20 (Included with Ref. No. 0600)
0600	1687805	1	KIT, Scraper Bar (Includes Ref. Nos. 0070, 0075 & Hardware)

Not for
Reproduction

Footnotes

The above parts group applies to the following Mfg. Nos.:

1696506-00 - 922EXD

1696506-01 - 922EXD

Engine Group

NOTE: Unless noted otherwise,
use the standard hardware torque
specification chart.

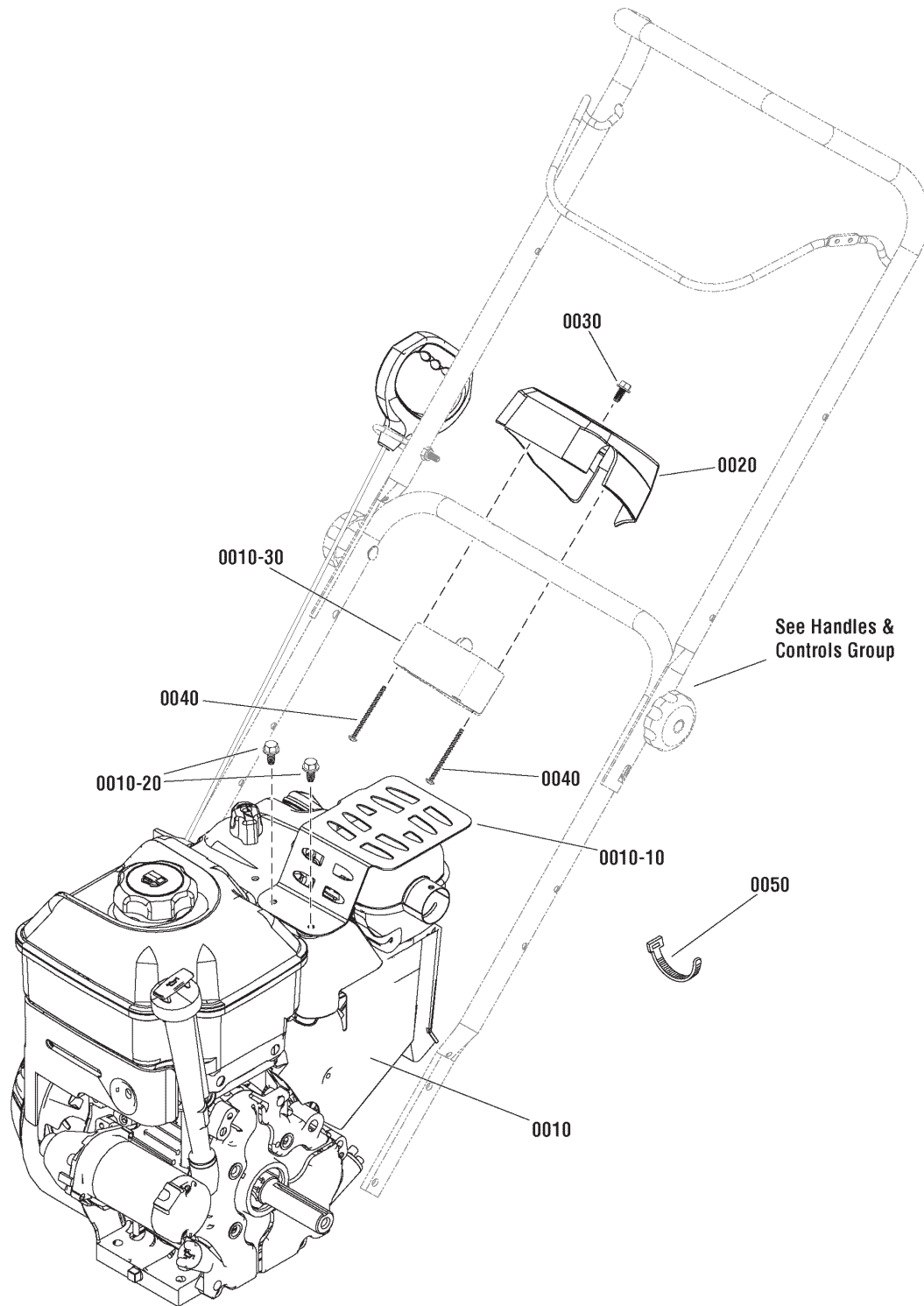

The above parts group applies to the following Mfg. Nos.:

1696506-00 - 922EXD

1696506-01 - 922EXD

Engine Group

REF NO	PART NO.	QTY.	DESCRIPTION
0010	12D105-0010-F8	1	* ENGINE, 9.0 Gross TP Briggs & Stratton (Engine Model: 12D105-0010-F8)
0010-10	797003	1	GUARD, Muffler, Plate
0010-20	699854	3	SCREW, Muffler Guard, Hex Washer Head
0010-30	-----	1	** STARTER, 110V
0020	1750032YP	1	HOUSING, Starter, 110V
0030	1750447YP	1	SCREW, Hex Washer Head, Trilob, 1/4-20 x 1/2
0040	1750593YP	2	SCREW, Pan Head Phillips, Plast., 8-16 x 2-1/8
0050	032618MA	4	STRAP, Tie

Not for
Reproduction

Footnotes

Note* To verify your specific engine model, please reference the ID Tag located on your engine. See your local Briggs & Stratton distributor for parts and service.

The above parts group applies to the following Mfg. Nos.:

1696506-00 - 922EXD
1696506-01 - 922EXD

Auger Drive Group

NOTE: Unless noted otherwise,
use the standard hardware torque
specification chart.

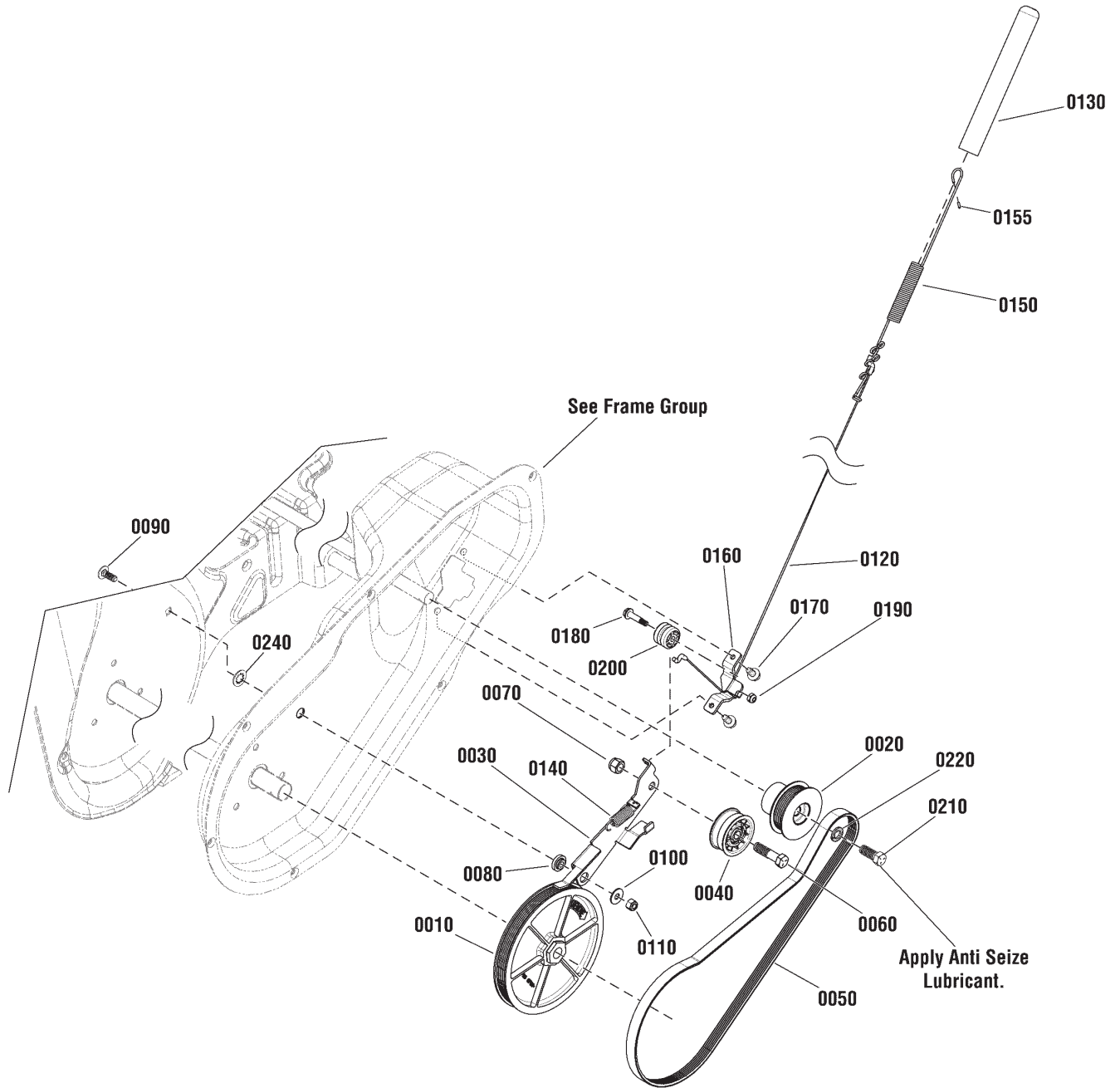

The above parts group applies to the following Mfg. Nos.:

1696506-00 - 922EXD

1696506-01 - 922EXD

Auger Drive Group

REF NO	PART NO.	QTY.	DESCRIPTION
0010	1739730YP	1	PULLEY, Driven
0020	1739179YP	1	PULLEY, Driver
0030	1739526YP	1	ARM, Idler, Drive
0040	1502120MA	1	IDLER, Plastic Ball Bearing
0050	1739338YP	1	BELT, Drive
0060	01X111MA	1	CAPSCREW, Hex Head, 3/8-16 x 1-1/2
0070	7091299SM	1	NUT, Nylock, 3/8
0080	1739709YP	1	SPACER, Idler Arm
0090	1931318SM	1	BOLT, Carriage, Short Neck, 1/4-20 x 7/8 G5
0100	7091253YP	1	WASHER, Flat, .281 X 3/4 x 1/2
0110	7091603SM	1	NUT, Nylock, 1/4
0120	1502113MA	1	CABLE, Handle
0130	1739935YP	1	BOOT, Clutch Spring
0140	1750226YP	1	SPRING, Idler
0150	1750315YP	1	SPRING, Extension
0155	704137	1	COVER, Spring End
0160	1750329YP	1	BRACKET, Cable Guide
0170	1750447YP	2	SCREW, Hex Washer Head, Trilob, 1/4-20 x 1/2
0180	1750594YP	1	CAPSCREW, Hex Shoulder, 1/4 x 3/4
0190	7090376YP	1	NUT, Locking, #10
0200	579860MA	1	SPOOL CABLE, Auger Control
0210	001X20MA	1	CAPSCREW, Hex Head, 3/8-24 x 1
0220	22237GS	1	WASHER, Locking, 3/8
0240	1960518SM	1	NUT, Push, 1/4

Not for
Reproduction

Footnotes

The above parts group applies to the following Mfg. Nos.:

1696506-00 - 922EXD

1696506-01 - 922EXD

Handles & Controls Group - Remote

NOTE: Unless noted otherwise,
use the standard hardware torque
specification chart.

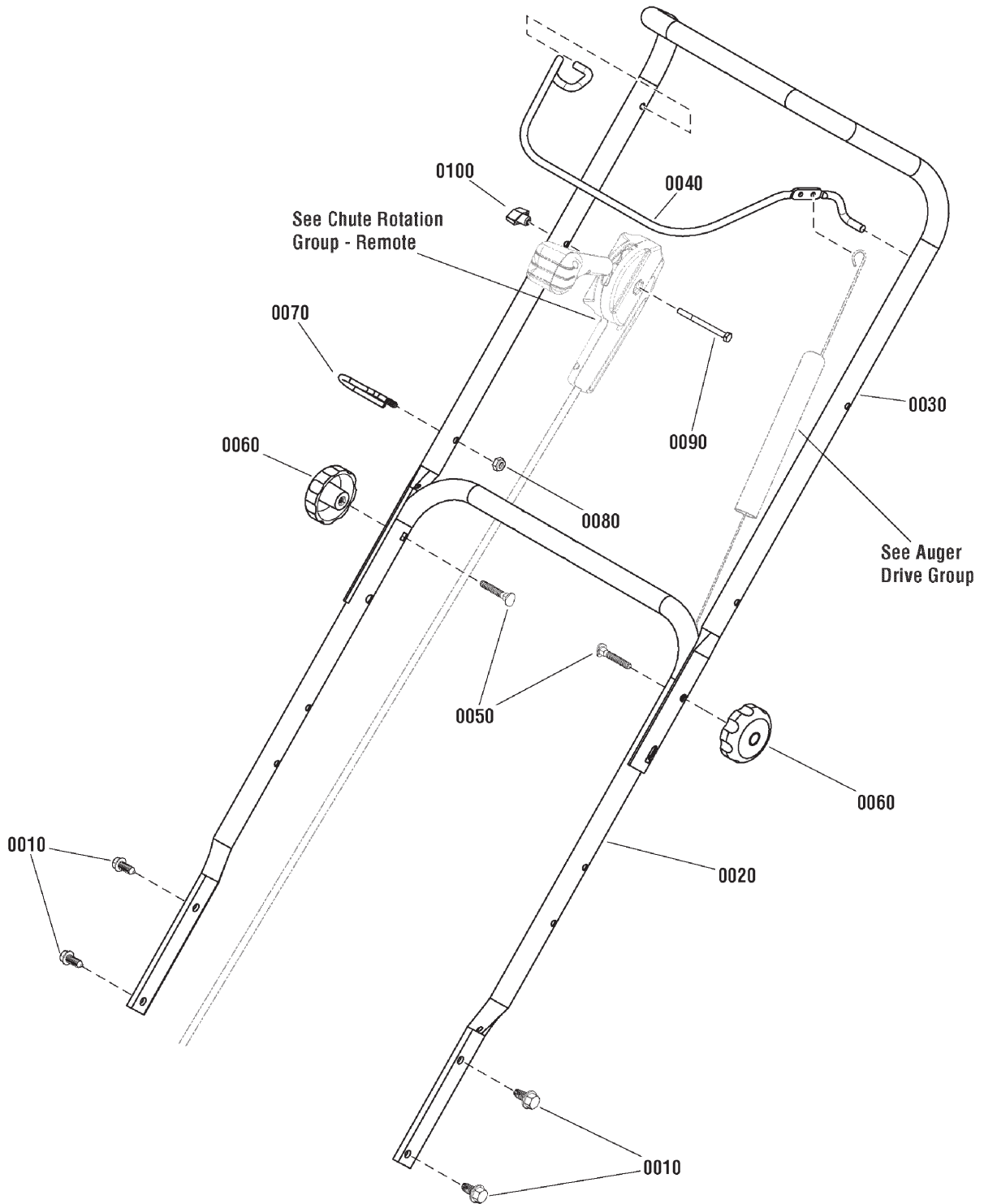

The above parts group applies to the following Mfg. Nos.:

1696506-00 - 922EXD

1696506-01 - 922EXD

Handles & Controls Group - Remote

REF NO	PART NO.	QTY.	DESCRIPTION
0010	1930601SM	4	SCREW, Hex Washer Head, Taptite, 5/16-18 x 5/8
0020	1739362AYP	1	HANDLEBAR, Lower
0030	1739363AYP	1	HANDLEBAR, Upper
0040	1739361BNYP	1	BAIL, Engine Stop
0050	7091189YP	2	BOLT, Carriage, Curved Head, 5/16 x 2, G2
0060	1101453MA	2	KNOB, Handle, 5/16-18
0070	1739389YP	1	GUIDE, Rope
0080	7091603SM	1	NUT, 1/4
0090	7091317YP	1	CAPSCREW, Hex Head, 1/4-20 x 3, G5
0100	194289GS	1	KNOB, Handle

Not for
Reproduction

Footnotes

The above parts group applies to the following Mfg. Nos.:

1696506-00 - 922EXD

1696506-01 - 922EXD

Wheel & Body Covering Group

NOTE: Unless noted otherwise,
use the standard hardware torque
specification chart.

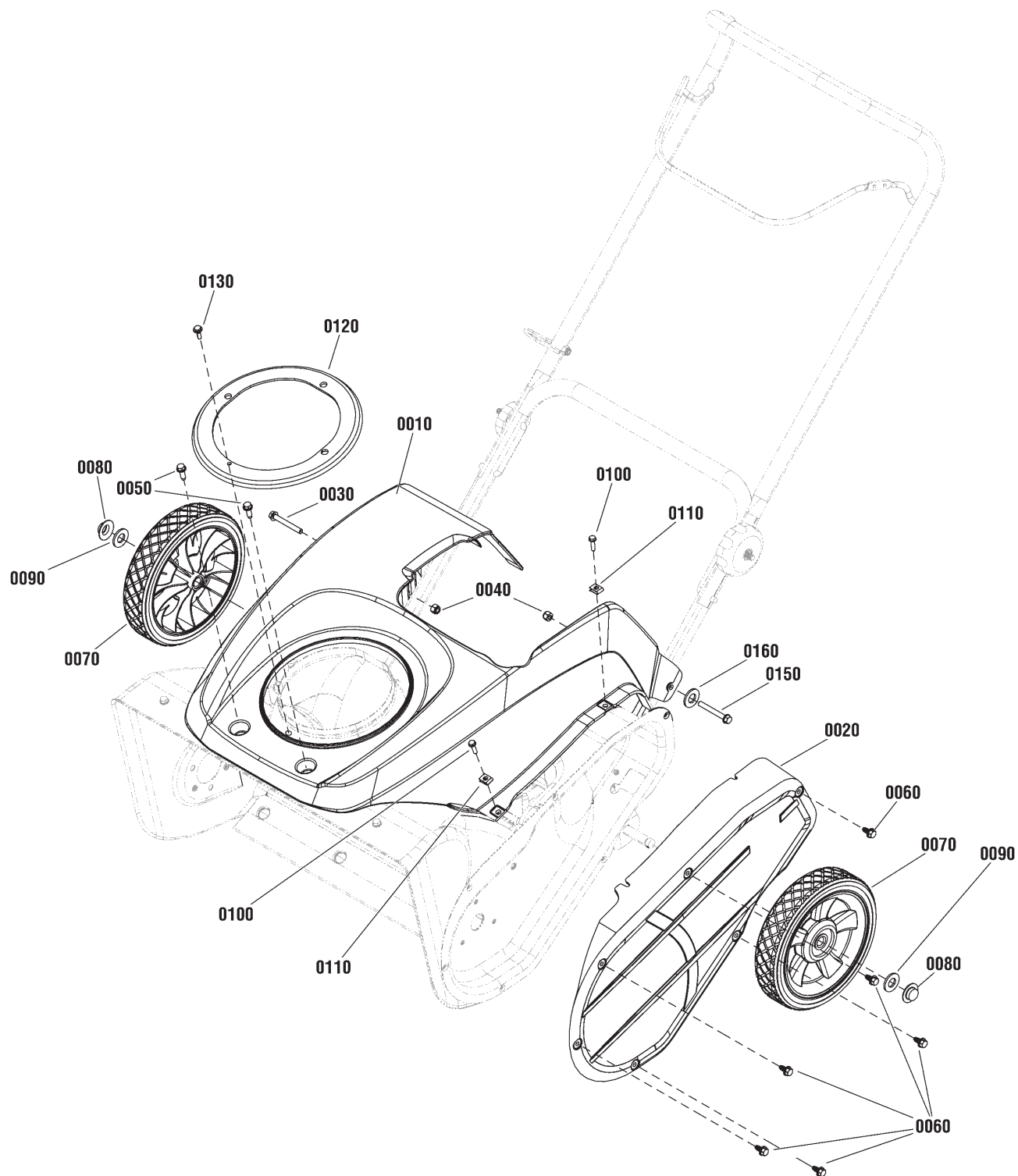

The above parts group applies to the following Mfg. Nos.:

1696506-00 - 922EXD

Wheel & Body Covering Group

REF NO	PART NO.	QTY.	DESCRIPTION
0010	1754520YP	1	COVER, Top
0020	1739599YP	1	COVER, Drive Case, Black
0030	1750777YP	1	CAPSCREW, Hex Washer Head, 1/4 x 20 x 2
0040	703232	2	NUT, Nylock, 1/4
0050	1750444YP	2	SCREW, Hi-Low, 1/4-15 x 3/4
0060	1750447YP	6	SCREW, Hex Washer Head, Trilob, 1/4-20 x 1/2
0070	311237YP	2	WHEEL, 2 x 8, Plastic 1/2
0080	703179	2	PUSHNUT, 1/2
0090	7025074SM	2	WASHER, Flat, 17/32 x 5/8
0100	1750638YP	2	CAPSCREW, Hex Washer Head, 10-24 x 3/4
0110	885118YP	2	NUT, U-Style Speed, #10
0120	1739752YP	1	COVER, Chute Moisture
0130	316042MA	1	SCREW, Hex Washer Head, #10-HL x 5/8
0150	703588	1	CAPSCREW, Hex Head, 1/4-20 x 1-3/4
0160	703332	1	WASHER, Flat, 1/4

Not for
Reproduction

Footnotes

The above parts group applies to the following Mfg. Nos.:

1696506-00 - 922EXD

Wheel & Body Covering Group

NOTE: Unless noted otherwise,
use the standard hardware torque
specification chart.

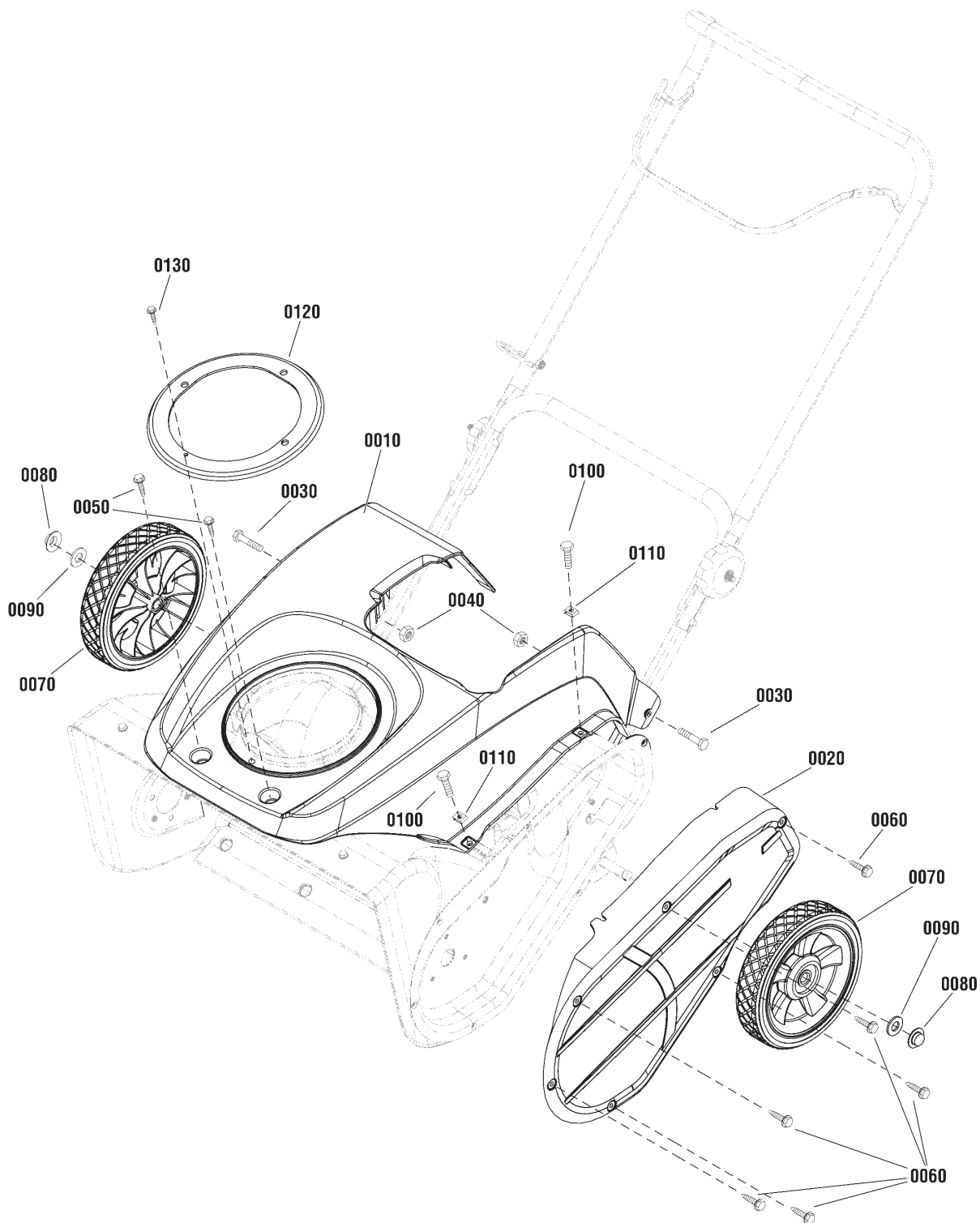

The above parts group applies to the following Mfg. Nos.:
1696506-01 - 922EXD

Wheel & Body Covering Group

REF NO	PART NO.	QTY.	DESCRIPTION
0010	1754520YP	1	COVER, Top
0020	1739599YP	1	COVER, Drive Case, Black
0030	1750777YP	2	CAPSCREW, Hex Washer Head, 1/4 x 20 x 2
0040	703232	2	NUT, Nylock, 1/4
0050	1750444YP	2	SCREW, Hi-Low, 1/4-15 x 3/4
0060	1750447YP	6	SCREW, Hex Washer Head, Trilob, 1/4-20 x 1/2
0070	311237YP	2	WHEEL, 2 x 8, Plastic 1/2
0080	703179	2	PUSHNUT, 1/2
0090	7025074SM	2	WASHER, Flat, 17/32 x 5/8
0100	1750638YP	2	CAPSCREW, Hex Washer Head, 10-24 x 3/4
0110	885118YP	2	NUT, U-Style Speed, #10
0120	1739752YP	1	COVER, Chute Moisture
0130	316042MA	1	SCREW, Hex Washer Head, #10-HL x 5/8

Not for
Reproduction



Footnotes

The above parts group applies to the following Mfg. Nos.:

1696506-01 - 922EXD

Decals Group

NOTE: Unless noted otherwise, use the standard hardware torque specification chart.

⚠ DANGER	
Shut off engine and remove key before performing maintenance or repair work.	 Arrêter le moteur et retirer la clé avant d'effectuer tout entretien ou toute réparation.
Read the operator's manual for operating and safety instructions.	 Lire les consignes de sécurité et d'utilisation dans le manuel d'utilisation.
Thrown Objects Hazard • Never direct discharge chute towards persons or property.	Danger objets projetés • Ne jamais diriger la chute en direction des personnes ou biens matériels.
Amputation Hazard • Contact with auger will cause serious injury. • Keep hands, feet and clothing away. • Keep bystanders away.	Risque d'amputation • Tout contact avec la tarière provoquera de graves blessures. • Tenir vos pieds, vos mains et vêtements à distance. • Tenir les spectateurs à distance.

1729685





0010

⚠ DANGER	
Amputation hazard Contact with moving parts inside chute will cause serious injury. • Shut off engine before unclogging discharge chute. • Use clean-out tool, not hands!	
Risque d'amputation Tout contact avec des pièces en mouvement à l'intérieur de la goulotte provoquera de graves blessures. • Arrêter le moteur avant de dégager la goulotte d'éjection. • Utiliser l'outil de dégagement, pas les mains!	

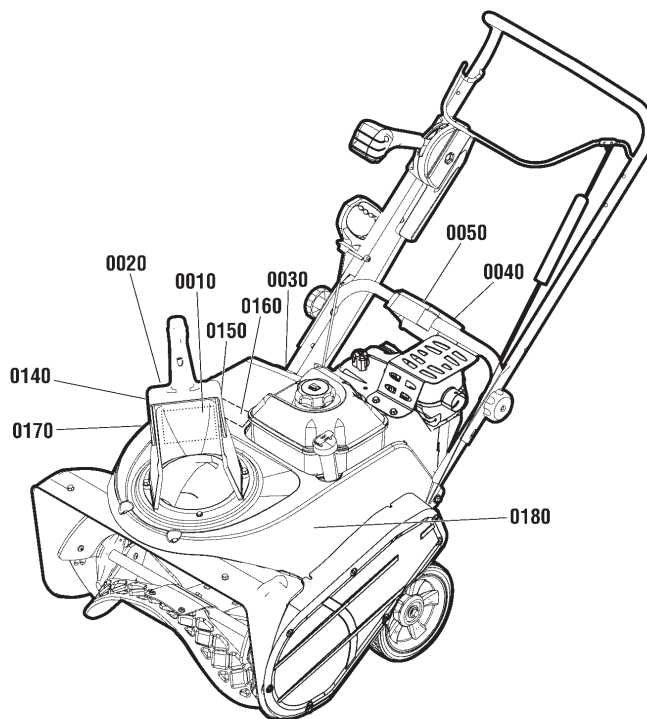
1729685

0020



STEPS TO EASY STARTING	
ÉTAPES POUR UN DÉMARRAGE FACILE	
1 	Turn engine ON Mettez le moteur sur « ON » (marche)
2 	Turn choke knob to CHOKE Tournez le bouton de l'étrangleur sur « CHOKE »
3 	For COLD engine PRIME 2X Si le moteur est FROID amorcez-le 2 fois
	After engine starts, turn to RUN Une fois le moteur en marche, mettez-le sur « RUN »

0030

ASSEMBLED IN THE USA

0130



0040



0050



0060

922EXD

0160



0170

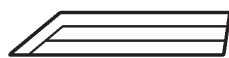

0140

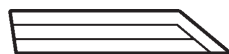

0150



0180

The above parts group applies to the following Mfg. Nos.:

1696506-00 - 922EXD

1696506-01 - 922EXD

Decals Group

REF NO	PART NO.	QTY.	DESCRIPTION
0010	1739966YP	1	DECAL, Chute, FR/ENG
0020	1737865YP	1	DECAL, Danger, Chute, FR/ENG
0030	1739970YP	1	DECAL, Step 1-2-3
0040	1750734YP	1	DECAL, 4 Start, FR/ENG
0050	1750736YP	1	DECAL, 5 Start, FR/ENG
0060	1739977YP	1	DECAL, Bail Engagement
0130	1754247YP	1	DECAL, Assembled in USA
0140	1750658YP	1	DECAL, Logo, Chute, RH
0150	1750657YP	1	DECAL, Logo, Chute, LH
0160	706611	1	DECAL, Briggs & Stratton, 922EXD
0170	706543	1	DECAL, Briggs & Stratton, RH
0180	706544	1	DECAL, Briggs & Stratton, LH

Not for
Reproduction

Footnotes

The above parts group applies to the following Mfg. Nos.:

1696506-00 - 922EXD

1696506-01 - 922EXD

Chute Rotation Group - Remote

NOTE: Unless noted otherwise, use the standard hardware torque specification chart.

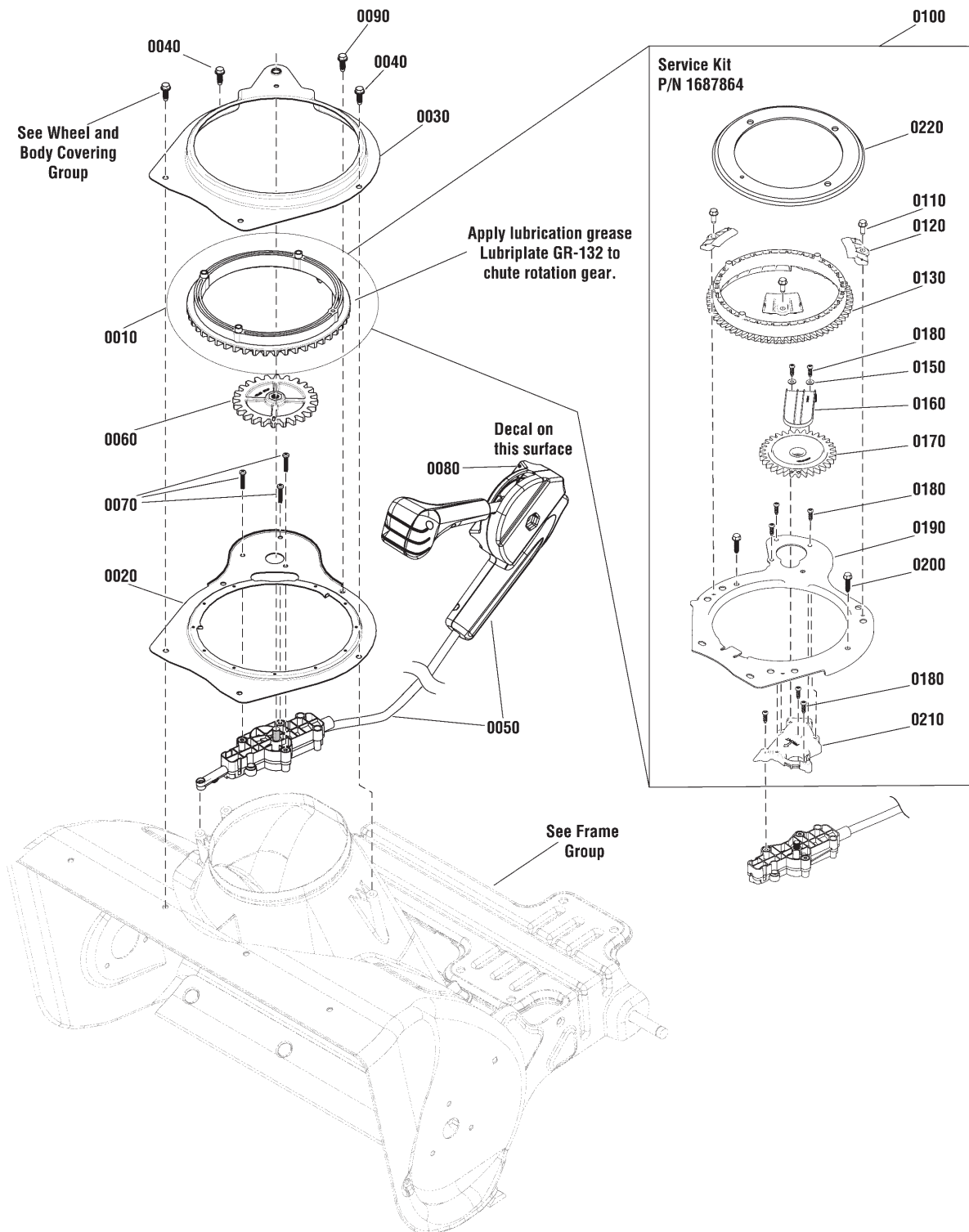

The above parts group applies to the following Mfg. Nos.:
1696506-00 - 922EXD

Chute Rotation Group - Remote

REF NO	PART NO.	QTY.	DESCRIPTION
0010	1739123YP	1	GEAR, Chute Rotation
0020	1739364YP	1	PLATE, Chute Mounting
0030	1739365YP	1	RETAINER, Chute Gear
0040	7091081SM	2	SCREW, Hi-Low, 1/4-15 x 3/4
0050	1739754YP	1	CHUTE ROTATION ASSEMBLY, Remote
0060	1738955YP	1	GEAR, Chute Rotation
0070	7100225YP	4	SCREW, Phillips Pan, Plastite, 8-16 x 1
0080	1739976YP	1	DECAL, Chute Rotation
0090	1750447YP	1	SCREW, Hex Washer Head, Trilob, 1/4-20 x 1/2
0100	1687864	1	KIT, Remote Chute Rotation (Includes items 0110, 0120, 0130, 0150, 0160, 0170, 0180, 0190, 0200, 0210 and 0220.)
0110	703054	3	SCREW, Washer Head Thread Rolling, 1/4-20 x 5/8
0120	706511	3	RETAINER
0130	706509	1	GEAR, Chute Rotation
0150	708699	2	WASHER, Flat
0160	708698	1	HOLD DOWN, Gear
0170	708697	1	GEAR, Quick Chute Assembly
0180	704209	8	SCREW, #8-16 Torx Plus, RH, Twin Helix
0190	708695	1	PLATE, Chute Rotation
0200	706516	2	SCREW, High-Low, 1/4-15 x 1
0210	708696	1	SPACER, Remote Chute Rotation Assembly
0220	708735	1	COVER, Chute Rotation Moisture

Not for
Reproduction

Footnotes

The above parts group applies to the following Mfg. Nos.:

1696506-00 - 922EXD

Chute Group - Remote

NOTE: Unless noted otherwise,
use the standard hardware torque
specification chart.

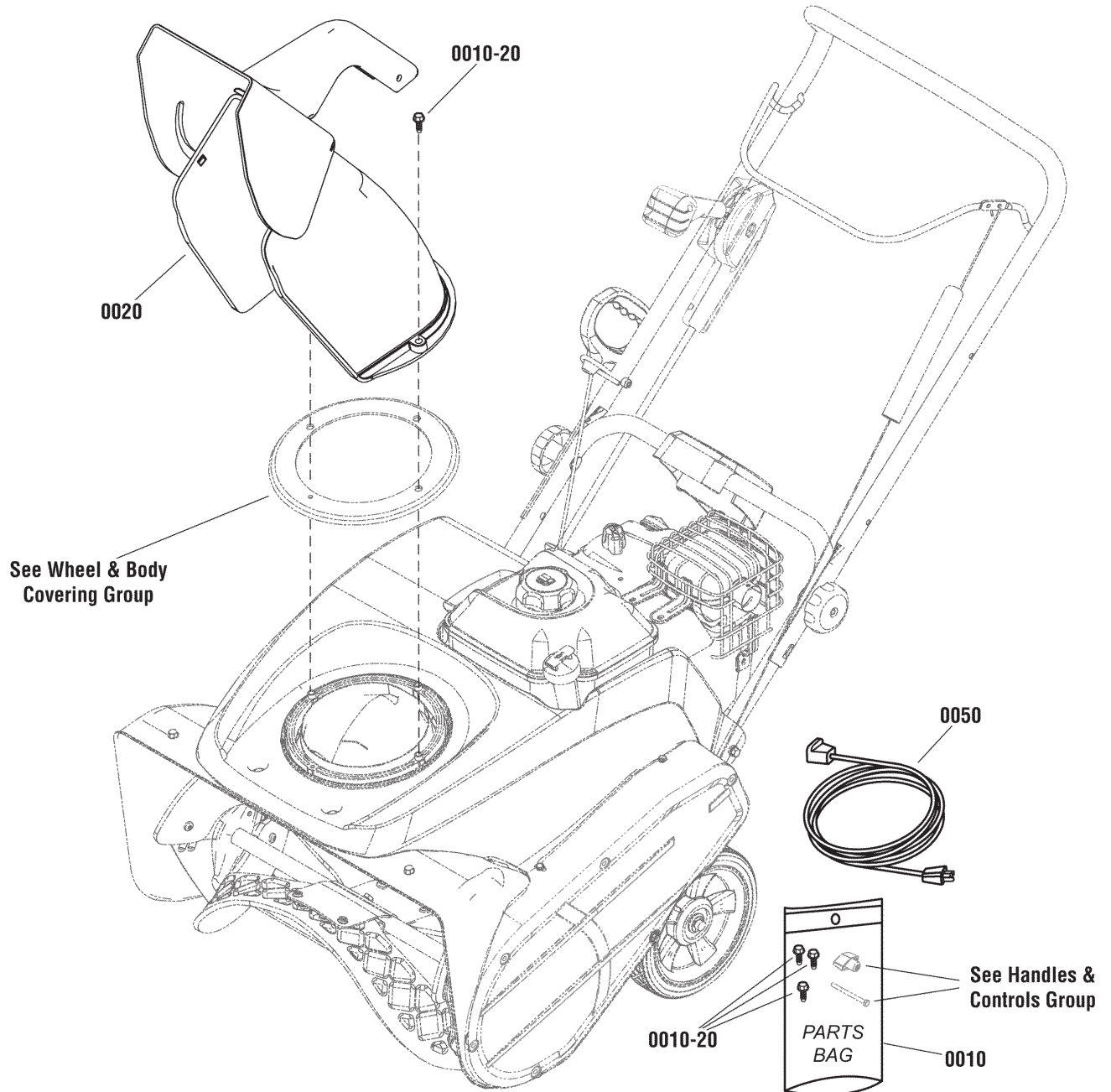

The above parts group applies to the following Mfg. Nos.:
1696506-00 - 922EXD

Chute Group - Remote

REF NO	PART NO.	QTY.	DESCRIPTION
0010	1751006YP	1	PARTS BAG
0010-20	1751399YP	3	SCREW, Hex Washer Head, HI-LO, 1/4-15 x 1-1/4
0020	1739522YP	1	CHUTE ASSEMBLY
0050	6219MA	1	CORD, Electric (North American models only)

Not for
Reproduction

Footnotes

The above parts group applies to the following Mfg. Nos.:

1696506-00 - 922EXD

Auger Group

NOTE: Unless noted otherwise,
use the standard hardware torque
specification chart.

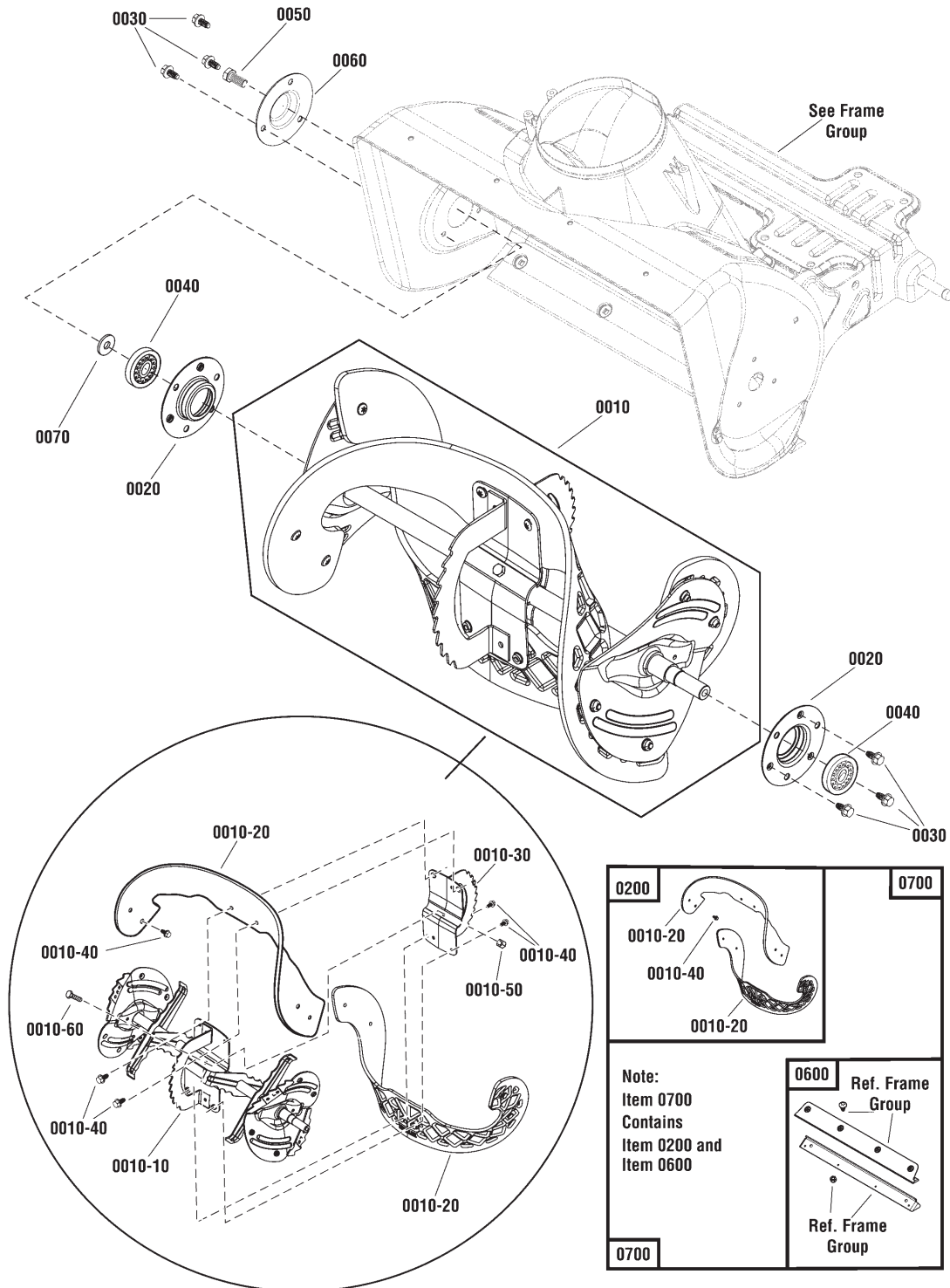

The above parts group applies to the following Mfg. Nos.:

1696506-00 - 922EXD

1696506-01 - 922EXD

Auger Group

REF NO	PART NO.	QTY.	DESCRIPTION
0010	1687814	1	AUGER ASSEMBLY, Complete (Incl. Ref. Nos. 0010-10, 0010-20, 0010-30, 0010-40, 0010-50 & 0010-60)
0010-10	-----	1	* AUGER SHAFT ASSEMBLY
0010-20	-----	2	** FLIGHT, Auger (Included with Ref. No. 0200)
0010-30	-----	2	* PLATE, Auger, Center
0010-40	7091246YP	12	SCREW, Pan Head Torx, 1/4-20 x 3/4 (Included with Ref. No. 0200)
0010-50	7091603SM	1	NUT, Nylock, 1/4-20
0010-60	703234	1	CAPSCREW, Hex Head, 1/4-20 X 1 1/2, G5
0020	1739228YP	2	RETAINER, Bearing
0030	1750447YP	6	SCREW, Hex Washer Head, Trilob, 1/4-20 x 1/2
0040	1705897SM	2	BEARING, Ball, 11/16 x 1-9/16 x 15/32
0050	704287	1	CAPSCREW, Hex Head, 5/16-18 x 3/4
0060	1739229AYP	1	CAP, BEARING
0070	7900022YP	1	WASHER, Flat, 7/8 x 21/64
0200	1687489YP	1	KIT, Auger Flight (Incl. Ref. Nos. 0030 & 0010-40)
0600	1687805	1	KIT, Scraper Bar (Reference Frame group)
0700	1687806	1	KIT, Scraper Bar & Flight (Incl. Ref. Nos. 0200 & 0600)

Not for
Reproduction

Footnotes

* Not a servicable part, order complete Auger Assembly.

** Not a servicable part, order Auger Flight Kit.

The above parts group applies to the following Mfg. Nos.:

1696506-00 - 922EXD

1696506-01 - 922EXD

Chute Group - Remote

NOTE: Unless noted otherwise,
use the standard hardware torque
specification chart.

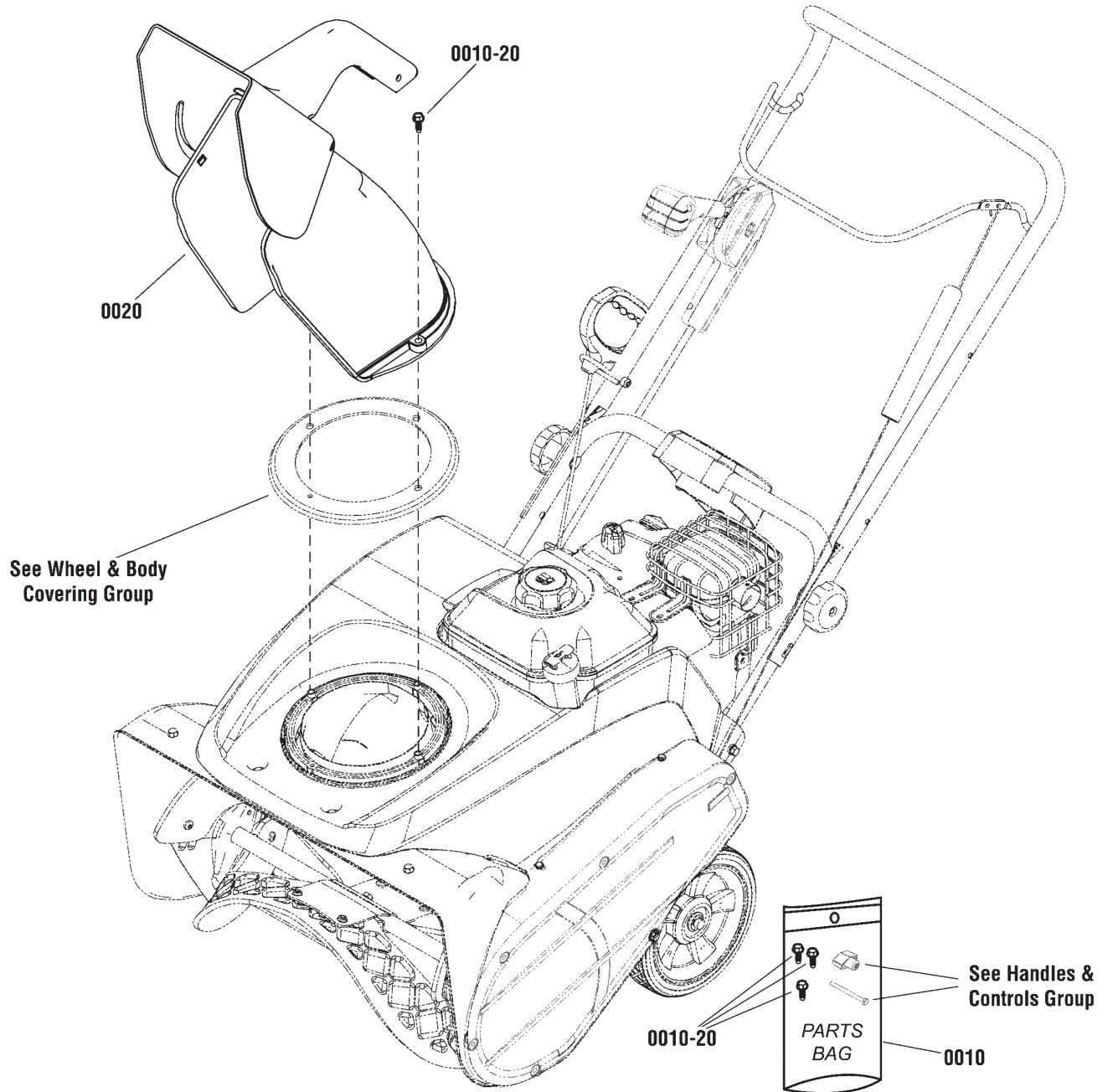

The above parts group applies to the following Mfg. Nos.:

1696506-01 - 922EXD

Chute Group - Remote

REF NO	PART NO.	QTY.	DESCRIPTION
0010	1751006YP	1	PARTS BAG
0010-20	1751399YP	3	SCREW, Hex Washer Head, HI-LO, 1/4-15 x 1-1/4
0020	1739522YP	1	CHUTE ASSEMBLY

Not for
Reproduction

Footnotes

The above parts group applies to the following Mfg. Nos.:

1696506-01 - 922EXD

Chute Rotation Group - Remote (After Serial Number 2017172524)

NOTE: Unless noted otherwise,
use the standard hardware torque
specification chart.

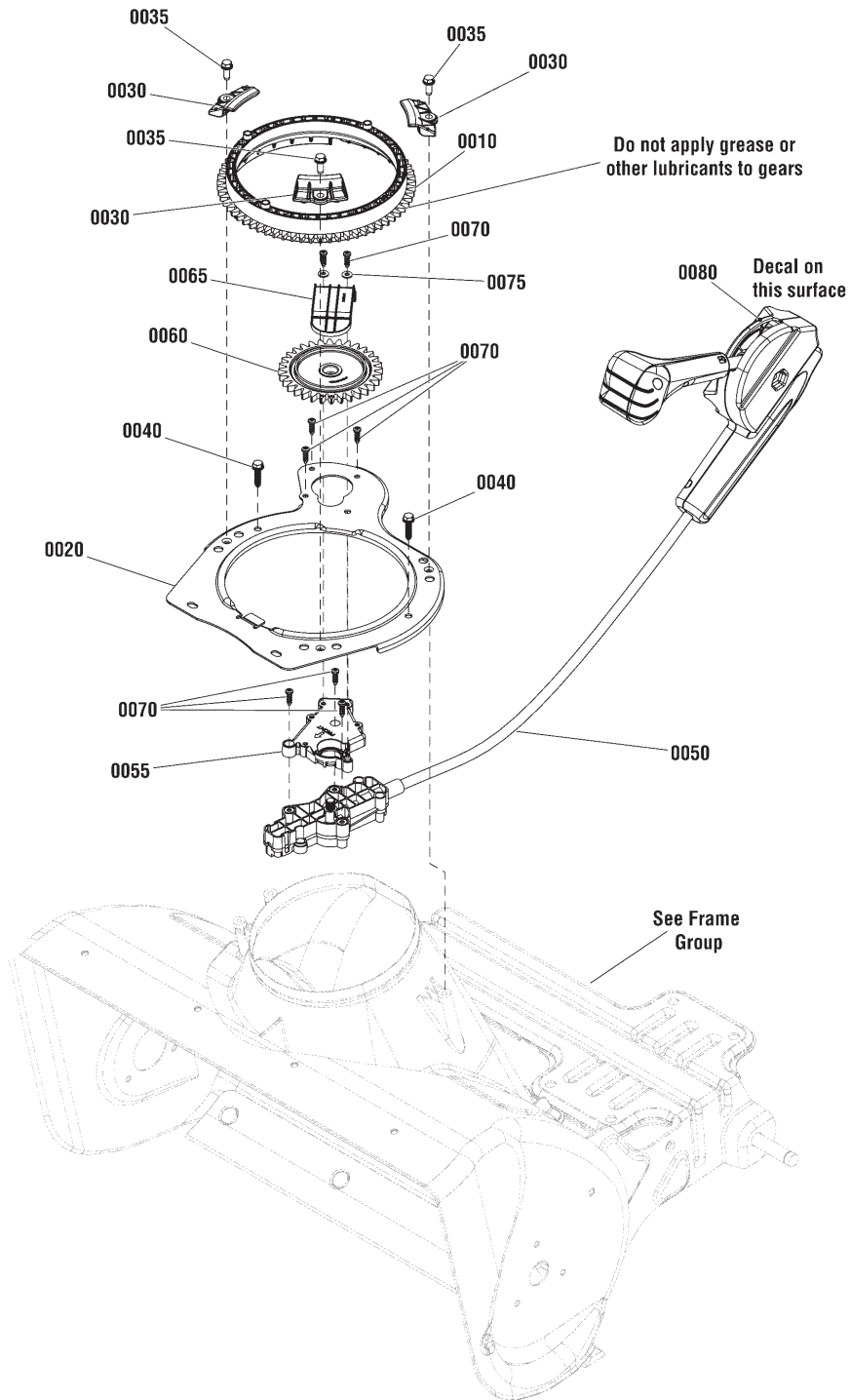

The above parts group applies to the following Mfg. Nos.:
1696506-01 - 922EXD

Chute Rotation Group - Remote (After Serial Number 2017172524)

REF NO	PART NO.	QTY.	DESCRIPTION
0010	706509	1	GEAR, Chute Rotation
0020	708695	1	PLATE, Chute Rotation
0030	706511	3	RETAINER, Chute Gear
0035	703054	3	SCREW, Hex Washer Head, Thread Roll, 1/4-20 x 5/8
0040	706516	2	SCREW, High-Low, 1/4-15 x 1.00
0050	1739754YP	1	CHUTE ROTATION ASSEMBLY, Remote
0055	708696	1	SPACER, Chute Rotation, Remote
0060	708697	1	GEAR ASSEMBLY, Quick Chute
0065	708698	1	HOLD DOWN, Gear
0070	704209	8	SCREW, #8-16X5/8, Torx, RH Twin Helix, ZC/CL
0075	708699	2	WASHER, Flat 7/16
0080	1739976YP	1	DECAL, Chute Rotation

Not for
Reproduction

Footnotes

The above parts group applies to the following Mfg. Nos.:

1696506-01 - 922EXD

Chute Rotation Group - Remote (Before Serial Number 2017158768)

NOTE: Unless noted otherwise, use the standard hardware torque specification chart.

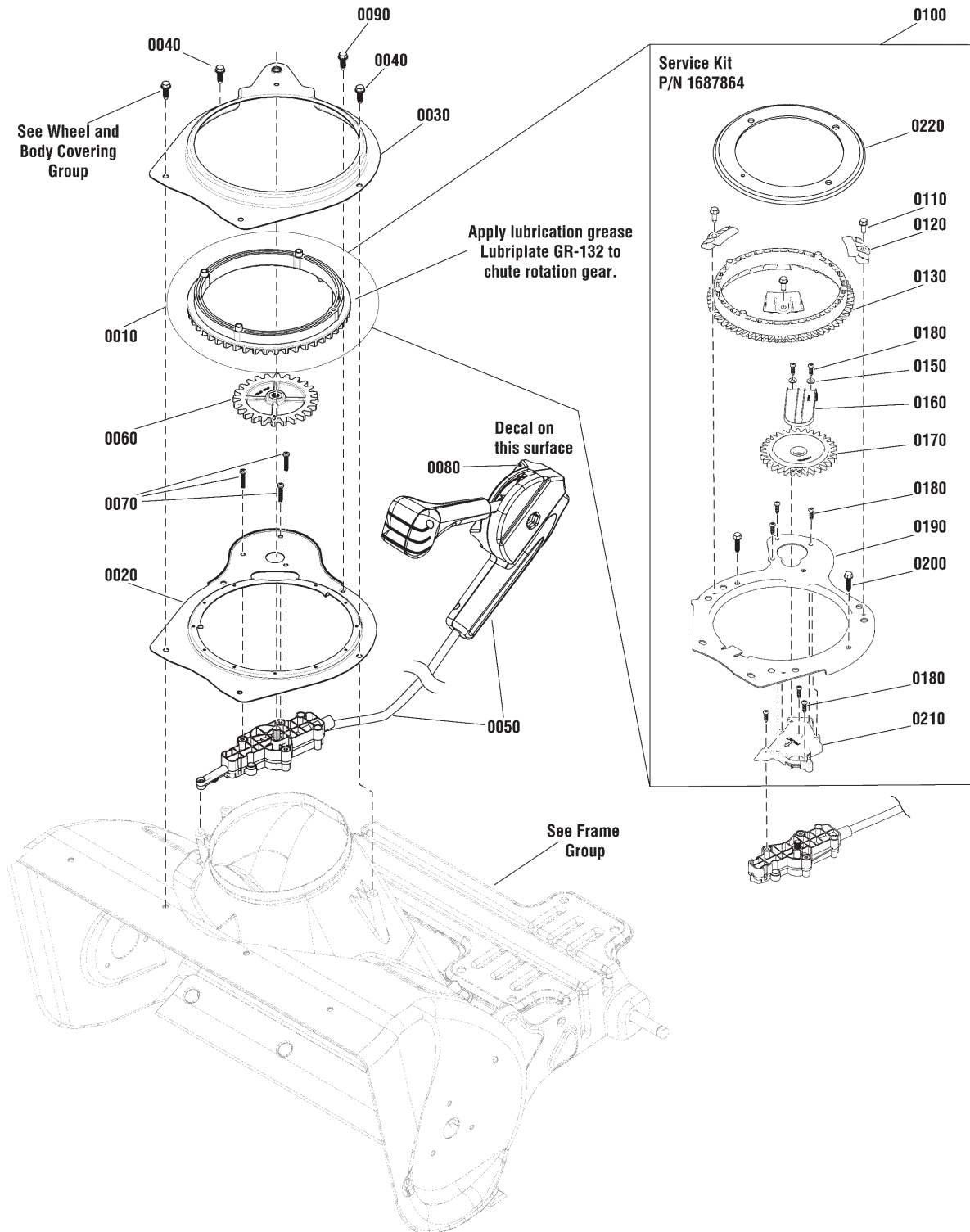

The above parts group applies to the following Mfg. Nos.:
1696506-01 - 922EXD

Chute Rotation Group - Remote (Before Serial Number 2017158768)

REF NO	PART NO.	QTY.	DESCRIPTION
0010	1739123YP	1	GEAR, Chute Rotation
0020	1739364YP	1	PLATE, Chute Mounting
0030	1739365YP	1	RETAINER, Chute Gear
0040	7091081SM	2	SCREW, Hi-Low, 1/4-15 x 3/4
0050	1739754YP	1	CHUTE ROTATION ASSEMBLY, Remote
0060	1738955YP	1	GEAR, Chute Rotation
0070	7100225YP	4	SCREW, Phillips Pan, Plastite, 8-16 x 1
0080	1739976YP	1	DECAL, Chute Rotation
0090	1750447YP	1	SCREW, Hex Washer Head, Trilob, 1/4-20 x 1/2
0100	1687864	1	KIT, Remote Chute Rotation (Includes items 0110, 0120, 0130, 0150, 0160, 0170, 0180, 0190, 0200, 0210 and 0220.)
0110	703054	3	SCREW, Washer Head Thread Rolling, 1/4-20 x 5/8
0120	706511	3	RETAINER
0130	706509	1	GEAR, Chute Rotation
0150	708699	2	WASHER, Flat
0160	708698	1	HOLD DOWN, Gear
0170	708697	1	GEAR, Quick Chute Assembly
0180	704209	8	SCREW, #8-16 Torx Plus, RH, Twin Helix
0190	708695	1	PLATE, Chute Rotation
0200	706516	2	SCREW, High-Low, 1/4-15 x 1
0210	708696	1	SPACER, Remote Chute Rotation Assembly
0220	708735	1	COVER, Chute Rotation Moisture

Not for
Reproduction

Footnotes

The above parts group applies to the following Mfg. Nos.:

1696506-01 - 922EXD

Not for
Reproduction

Hardware Identification & Torque Specifications

Torque Specification Chart								
FOR STANDARD METRIC MACHINE HARDWARE (Tolerance ± 20%)								
Property Class	5.6		8.8		10.9		12.9	
	Class 5.6		Class 8.8		Class 10.9		Class 12.9	
Size Of Hardware	in/lbs		in/lbs		in/lbs		in/lbs	
	ft/lbs	Nm.	ft/lbs	Nm.	ft/lbs	Nm.	ft/lbs	Nm.
M3	5.88	.56	13.44	1.28	19.2	1.80	22.92	2.15
M4	13.44	1.28	30.72	2.90	43.44	4.10	52.56	4.95
M5	26.4	2.50	60.96	5.75	5.97	8.10	7.15	9.7
M6	44.64	4.3	7.3	9.9	10.3	14	12.1	16.5
M7	5.2	7.1	12.1	16.5	16.9	23	19.9	27
M8	7.7	10.5	17.7	24	25	34	29	40
M10	15	21	35	48	50	67	59	81
M12	26	36	61	83	86.2	117	103	140
M14	42	58	101	132	136	185	162	220
M16	64	88	147	200	210	285	250	340
M18	89	121	202	275	287	390	346	470
M20	126	171	290	390	405	550	486	660
M22	169	230	390	530	559	745	656	890
M24	217	295	497	375	708	960	840	1140
M27	320	435	733	995	1032	1400	1239	1680
M30	435	590	995	1350	1401	1900	1681	2280
M33	590	800	1349	1830	1902	2580	2278	3090
M36	759	1030	1740	2360	2441	3310	2935	3980
M39	988	1340	2249	3050	3163	4290	3798	5150

The guides and ruler furnished below are designed to help you select the appropriate hardware.

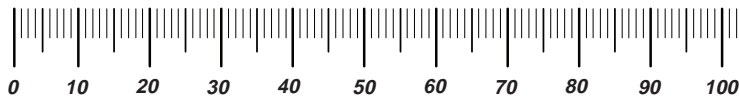

Nut, M8

Thread Diameter (mm)
Inside Diameter (in)
Threads per inch

Nut, 1/2-16

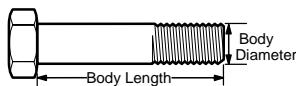

Screw, M8- 1.25 x 25

Thread Diameter (mm)
Body Diameter
Distance between threads (mm)
Threads per inch
Body Length (mm)
Body Length (in)

Screw, 1/2- 16 x 2

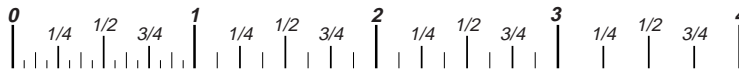

Standard Hardware Sizing

When a washer or nut is identified as **1/2"** (M8), this is the *Nominal size*, meaning the *inside diameter* is 1/2 inch (8mm metric thread diameter); if a second number is present it represents the *threads per inch* (distance between threads).

When bolt or capscrew is identified as **1/2 - 16 x 2"** (M8 - 1.25 x 50), this means the *Nominal size*, or body diameter is 1/2 inch (8mm metric thread diameter), the second number, 16, represents the *threads per inch*, (*1.25 thread diameter*). The final number is the body length of the bolt or screw, 2 inches (50mm).

Torque Specification Chart						
FOR STANDARD MACHINE HARDWARE (Tolerance ± 20%)						
Hardware Grade	No Marks		SAE Grade 5		SAE Grade 8	
	SAE Grade 2		SAE Grade 5		SAE Grade 8	
Size Of Hardware	in/lbs		in/lbs		in/lbs	
	ft/lbs	Nm.	ft/lbs	Nm.	ft/lbs	Nm.
8-32	19	2.1	30	3.4	41	4.6
8-36	20	2.3	31	3.5	43	4.9
10-24	27	3.1	43	4.9	60	6.8
10-32	31	3.5	49	5.5	68	7.7
1/4-20	66	7.6	8	10.9	12	16.3
1/4-28	76	8.6	10	13.6	14	19.0
5/16-18	11	15.0	17	23.1	25	34.0
5/16-24	12	16.3	19	25.8	29	34.0
3/8-16	20	27.2	30	40.8	45	61.2
3/8-24	23	31.3	35	47.6	50	68.0
7/16-14	30	40.8	50	68.0	70	95.2
7/16-20	35	47.6	55	74.8	80	108.8
1/2-13	50	68.0	75	102.0	110	149.6
1/2-20	55	74.8	90	122.4	120	163.2
9/16-12	65	88.4	110	149.6	150	204.0
9/16-18	75	102.0	120	163.2	170	231.2
5/8-11	90	122.4	150	204.0	220	299.2
5/8-18	100	136	180	244.8	240	326.4
3/4-10	160	217.6	260	353.6	386	525.0
3/4-16	180	244.8	300	408.0	420	571.2
7/8-9	140	190.4	400	544.0	600	816.0
7/8-14	155	210.8	440	598.4	660	897.6
1-8	220	299.2	580	788.8	900	1,244.0
1-12	240	326.4	640	870.4	1,000	1,360.0

NOTES

- These torque values are to be used for all hardware excluding: locknuts, self-tapping screws, thread forming screws, sheet metal screws and socket head setscrews.
- Recommended seating torque values for locknuts:
 - for prevailing torque locknuts - use 65% of grade 5 torques.
 - for flange whizlock nuts and screws - use 135% of grade 5 torques.
- Unless otherwise noted on assembly drawings, all torque values must meet this specification.

Common Hardware Types

Hex Head Capscrew

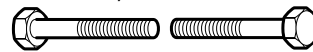

Washer

Carriage Bolt



Lockwasher



Hex Nut

Wrench & Fastener Size Guide

1/4" Bolt or Nut Wrench—7/16"	5/16" Bolt or Nut Wrench—1/2"	3/8" Bolt or Nut Wrench—9/16"	7/16" Bolt or Nut Wrench (Bolt)—5/8" Wrench (Nut)—11/16"	1/2" Bolt or Nut Wrench—3/4"
M6 Bolt or Nut Wrench—10mm	M8 Bolt or Nut Wrench—13mm	M10 Bolt or Nut Wrench—17mm	M12 Bolt or Nut Wrench—19mm	M14 Bolt or Nut Wrench—22mm



Not for
Reproduction

**IT IS THE POLICY OF BRIGGS & STRATTON CORP. TO IMPROVE ITS PRODUCTS
WHENEVER IT IS POSSIBLE AND PRACTICAL TO DO SO. WE RESERVE THE RIGHT TO
MAKE CHANGES OR ADD IMPROVEMENTS AT ANY TIME WITHOUT INCURRING ANY
OBLIGATION TO MAKE SUCH CHANGES ON PRODUCTS.**

Briggs & Stratton Power Products Group

12301 W. Wirth Street
Wauwatosa, WI, 53222 USA

www.BRIGGSandSTRATTON.com

© Copyright 2915 by Briggs & Stratton Corporation
Milwaukee, WI, USA. All rights reserved