



Parts Manual

Mfg. No: 1687914-00
SXD21SPWM82K, 82V Battery Electric



Model Components	Page
Battery & Cover Group.....	4
Handles Group.....	10
Wheels & Deck Group.....	14
Torque Specification Chart.....	16

Not For
Reproduction

Battery & Cover Group

Note: Unless noted otherwise, use the standard torque specifications

Mfg. No: 1687914-00

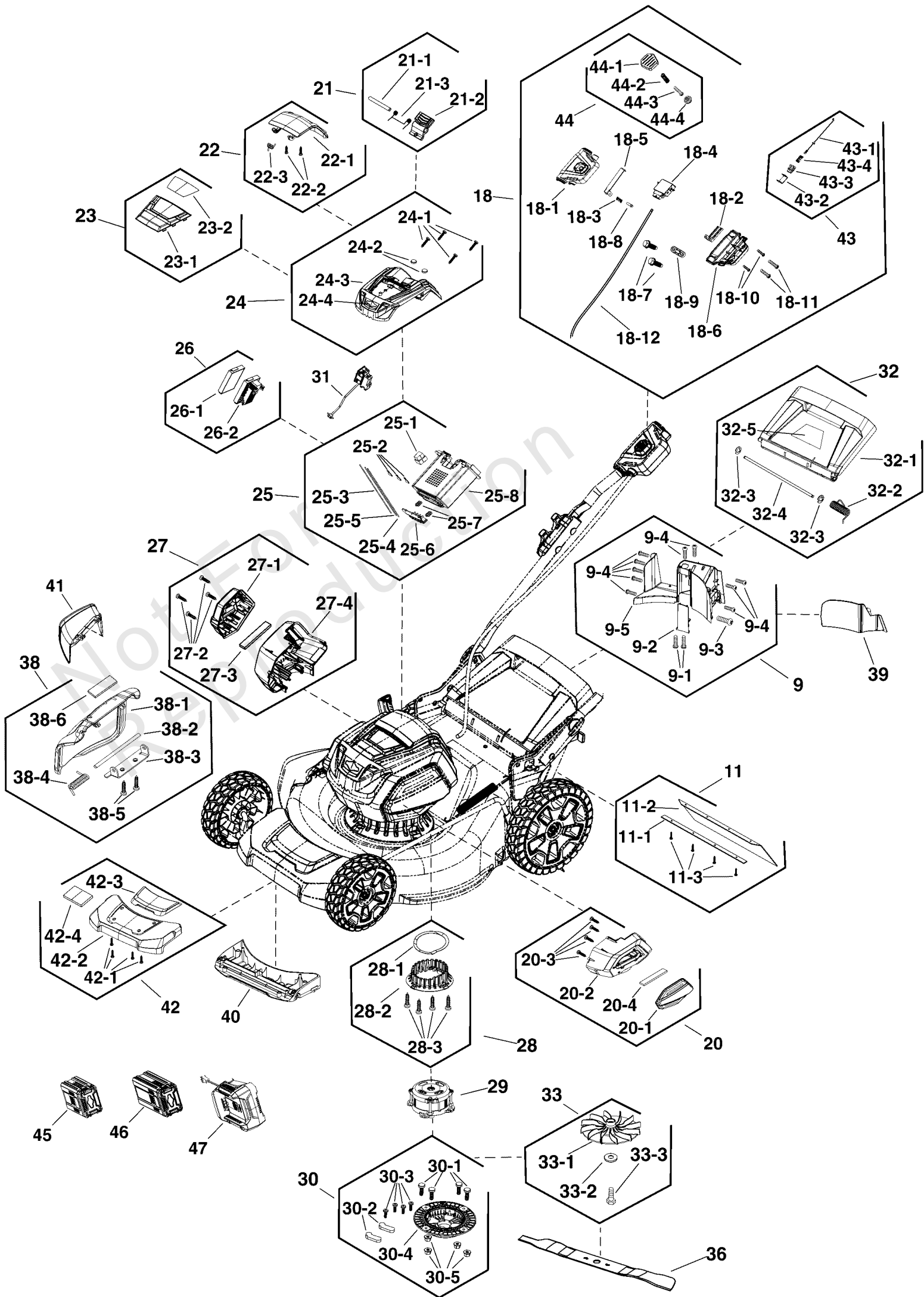

Battery & Cover Group

REF NO	PART NO	QTY	DESCRIPTION
9	771587	1	KIT, REAR BAFFLE
9-1		2	SCREW
9-2		1	COVER
9-3		1	SCREW
9-4		10	SCREW
9-5		1	BULKHEAD, BACK
11	771589	1	KIT, REAR FLAP
11-1		1	BRACE
11-2		1	REAR FLAP
11-3		4	SCREW ST4.2-16
18	770172	1	KIT, SWITCH BOX COMPONENT, NA -(Includes items 43 & 44)
18-1		1	TOP COVER
18-2		1	SLIDER
18-3		1	SPRING
18-4		1	SWITCH
18-5		1	PLATE
18-6		1	BOTTOM COVER
18-7	CM-3220505-1	2	SCREW
18-8		1	AXLE
18-9		1	CLAMP
18-10		2	SCREW
18-11	CM-3220404	2	SCREW
18-12		1	WIRE
20	770198	1	KIT, LEFT COVER
20-1		1	LEFT DECORATIVE COVER
20-2		1	LEFT COVER
20-3		4	SCREW
20-4		1	DUST SCREEN
21	770202	1	KIT, BATTERY RELEASE
21-1		1	PIN
21-2		1	BUTTON
21-3		1	SPRING
22	770195	1	KIT, BATTERY COVER
22-1		1	BATTERY DOOR
22-2		2	SCREW
22-3		1	SPRING
23	771599	1	KIT, DECORATIVE COVER
23-1		1	COVER
23-2		1	SHROUD
24	771600	1	KIT, TOP COVER
24-1		4	SCREW
24-2		2	MAGNET
24-3		1	TOP COVER
24-4		1	B&S LOGO
25	771601	1	KIT, BATTERY COMPARTMENT
25-1		1	CONNECTOR
25-2		3	CONTACT
25-3		1	WIRE
25-4		1	WIRE
25-5		1	WIRE

Battery & Cover Group

Note: Unless noted otherwise, use the standard torque specifications

Mfg. No: 1687914-00

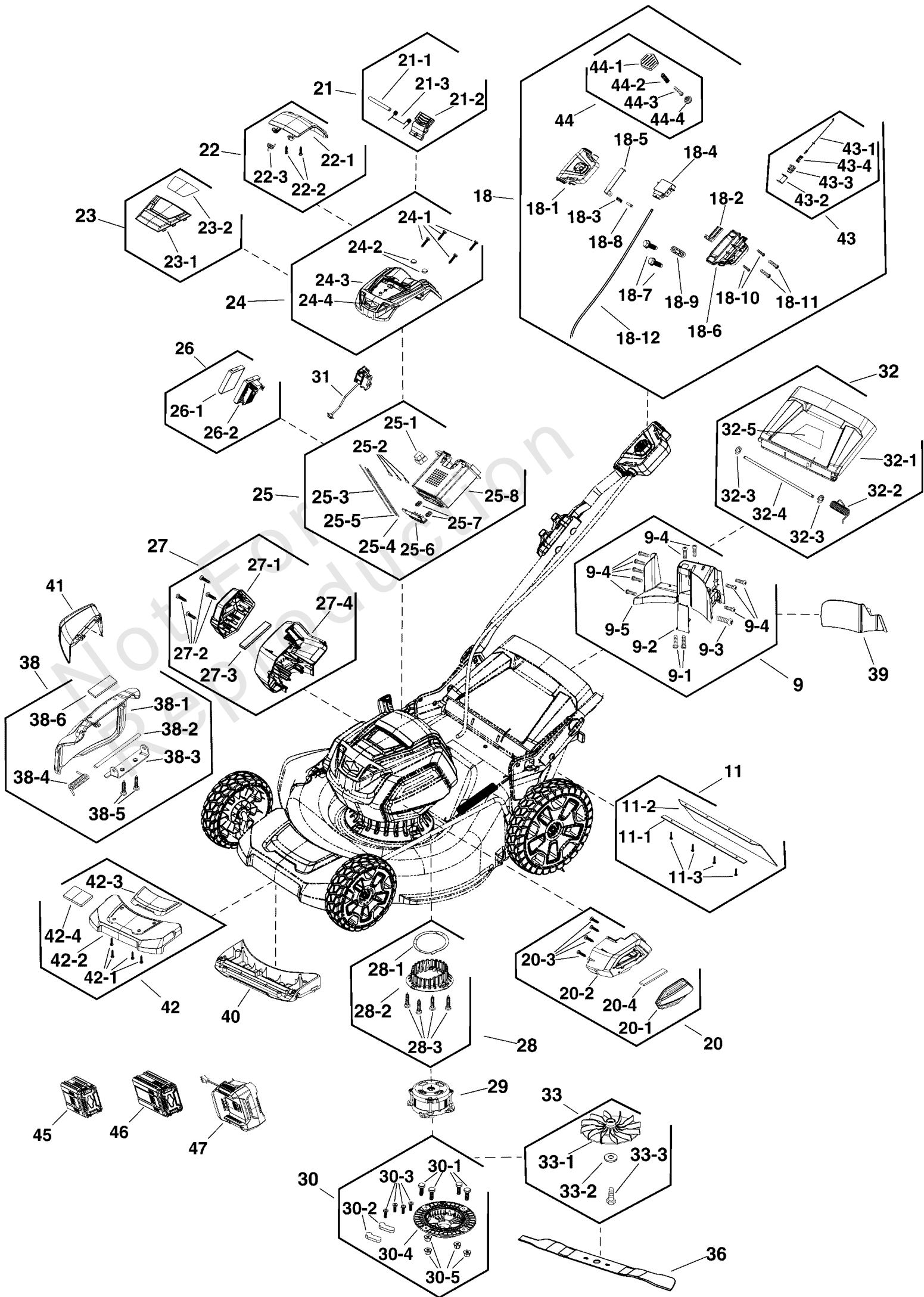

Battery & Cover Group

REF NO	PART NO	QTY	DESCRIPTION
25-6		1	BATTERY TERMINAL
25-7		2	SPRING
25-8		1	BATTERY HOUSING
26	771602	1	KIT, PCB
26-1		1	PCB COVER
26-2		1	PCB
27	770197	1	KIT, RIGHT COVER
27-1		1	RIGHT DECORATIVE COVER
27-2		4	SCREW
27-3		1	DUST SCREEN
27-4		1	RIGHT COVER
28	771603	1	KIT, BASE
28-1		1	SEAL
28-2		1	BASE
28-3		4	SCREW
29	770174	1	KIT, MOTOR
30	771604	1	KIT, MOTOR BASE
30-1		4	BOLT
30-2		2	TENSION DISC
30-3		4	SCREW
30-4		1	BASE
30-5		4	NUT
31	771605	1	KIT, INVERTED SWITCH
32	770181	1	KIT, REAR COVER ASSEMBLY
32-1		1	REAR COVER
32-2		1	SPRING
32-3		2	SPLIT WASHER
32-4		1	SHAFT
32-5		1	LABEL
33	771606	1	KIT, FAN
33-1		1	FAN
33-2		1	WASHER
33-3		1	BOLT M10X35
36	770191	1	KIT, BLADE
38	770193	1	KIT, COVER
38-1		1	COVER
38-2		1	SHAFT
38-3		1	BRACKET
38-4		1	SPRING
38-5		2	SPRING
38-6		1	SIDE DISCHARGE LABEL
39	770183	1	KIT, PLUG
40	770206	1	KIT, FRONT BULKHEAD
42	770192	1	KIT, FRONT PANEL
42-1		4	SCREW
42-2		1	PANEL
42-3		1	PANEL COVER
42-4		1	LABEL
43	770171	1	KIT, CABLE ASSEMBLY
43-1		1	CABLE
43-2		1	SLIDER

Battery & Cover Group

Note: Unless noted otherwise, use the standard torque specifications

Mfg. No: 1687914-00

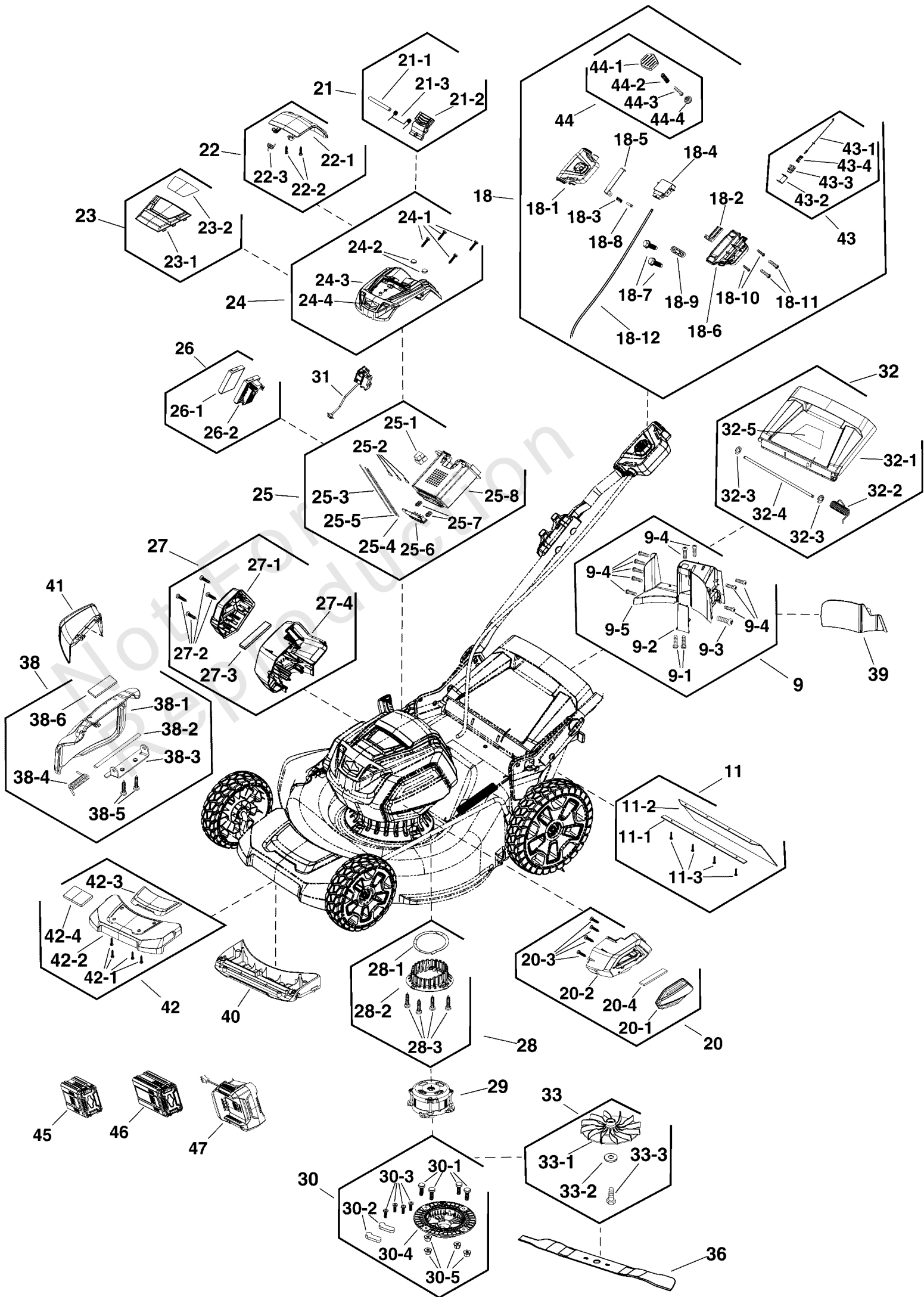

Battery & Cover Group

REF NO	PART NO	QTY	DESCRIPTION
43-3		1	SEAT
43-4		1	SPRING
44	770173	1	KIT, BUTTON
44-1		1	BUTTON
44-2		1	SPRING
44-4		1	COVER
44-3	CM-3221675A	1	SCREW
45	1760266	1	BATTERY, 2AH, NA
46	1760265	1	BATTERY, 4AH, NA
47	1760263	1	CHARGER, RAPID, NA
--	770294	1	REMOTE BELT FOR BATTERY -(Not Shown)

Not For
Reproduction

Handles Group

Note: Unless noted otherwise, use the standard torque specifications

Mfg. No: 1687914-00

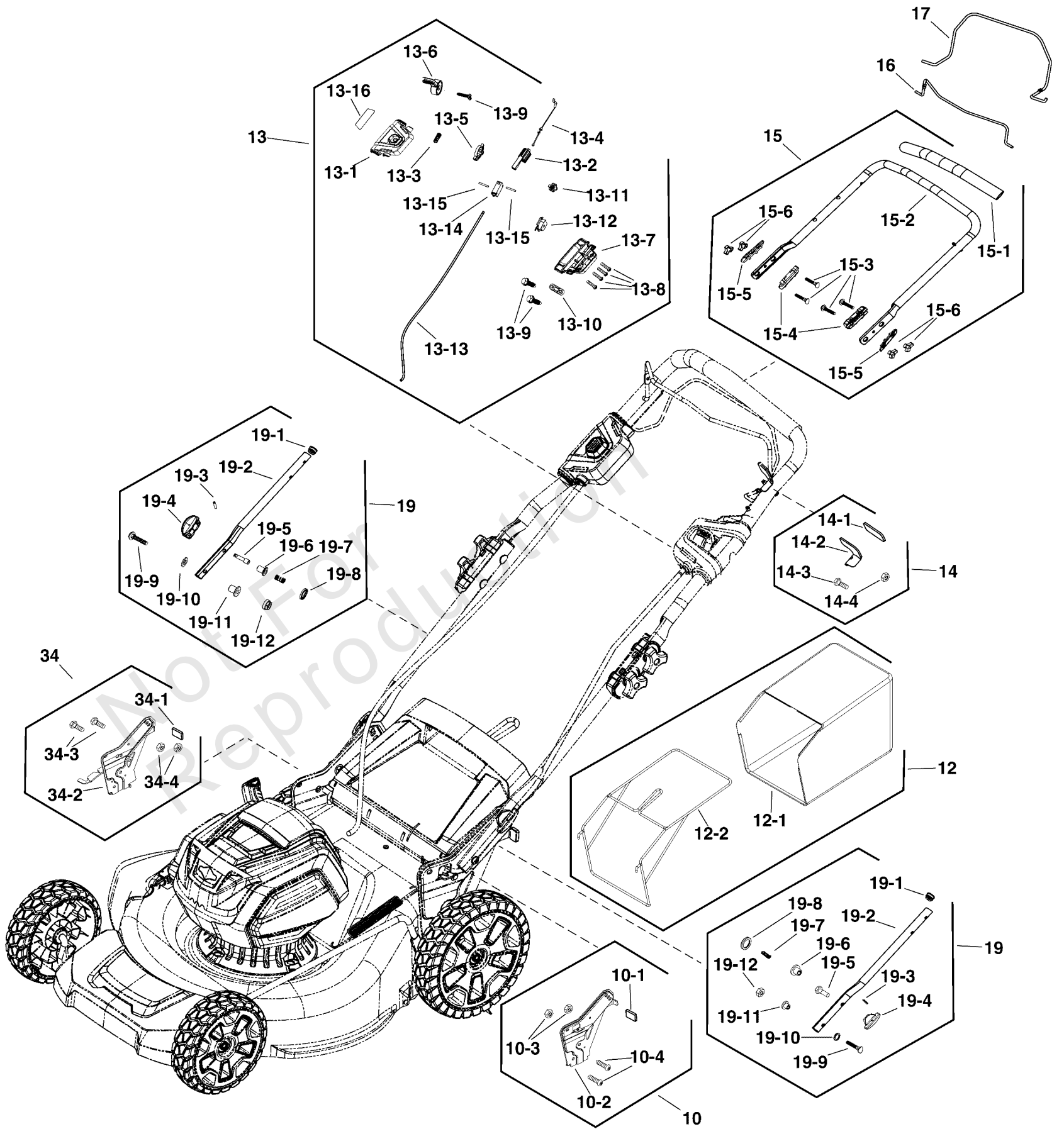

Handles Group

REF NO	PART NO	QTY	DESCRIPTION
10	771588	1	KIT, LEFT HEIGHT ADJUST
10-1		1	BUMPER
10-2		1	LEFT HEIGHT ADJUST
10-3		2	NUT
10-4		2	BOLT
12	770182	1	KIT, GRASS BAGGER
12-1		1	GRASS BAG
12-2		1	FRAME
13	771590	1	KIT, SPEED CONTROL
13-1		1	SWITCH BOX COVER
13-2		1	SLIDER
13-3		1	SPRING
13-4		1	CABLE
13-5		1	SELF-PROPEL GEAR, BIG
13-6		1	BUTTON, PUSH
13-7		1	SWITCH BOX COVER
13-8	CM-3220404D	4	SCREW ST4.2*25
13-9		3	SCREW ST4.2-16
13-10		1	CLAMP
13-11		1	BLOCK
13-12		1	SELF-PROPEL GEAR, SMALL
13-13		1	CABLE, SPEED CONTROLS
13-14		1	SWITCH
13-15		1	PIN
13-16		1	LABEL
14	771594	1	KIT, STOP
14-1		1	SPONGE
14-2		1	BRACKET
14-3		1	BOLT M5X35
14-4		1	NUT
15	771595	1	KIT, UPPER HANDLE
15-1		1	FOAM GRIP
15-2		1	HANDLE, UPPER
15-3		4	BOLT M8
15-4		2	HANDLE BRACKET INSIDE
15-5		2	HANDLE BRACKET OUTSIDE
15-6		4	KNOB
16	770169	1	KIT, LEVER
17	771596	1	KIT, SELF-PROPELLED LEVER
19	771597	2	KIT, LOWER HANDLE
19-1		1	TUBE CAP
19-2		1	HANDLE, LOWER
19-3		1	PIN
19-4		1	KNOB
19-5		1	ADJUSTMENT PIN
19-6		1	BUSHING
19-7		1	SPRING
19-8		1	GASKET
19-9		1	BOLT M8X35
19-10		1	FLAT WASHER
19-11		1	NUT

Handles Group

Note: Unless noted otherwise, use the standard torque specifications

Mfg. No: 1687914-00

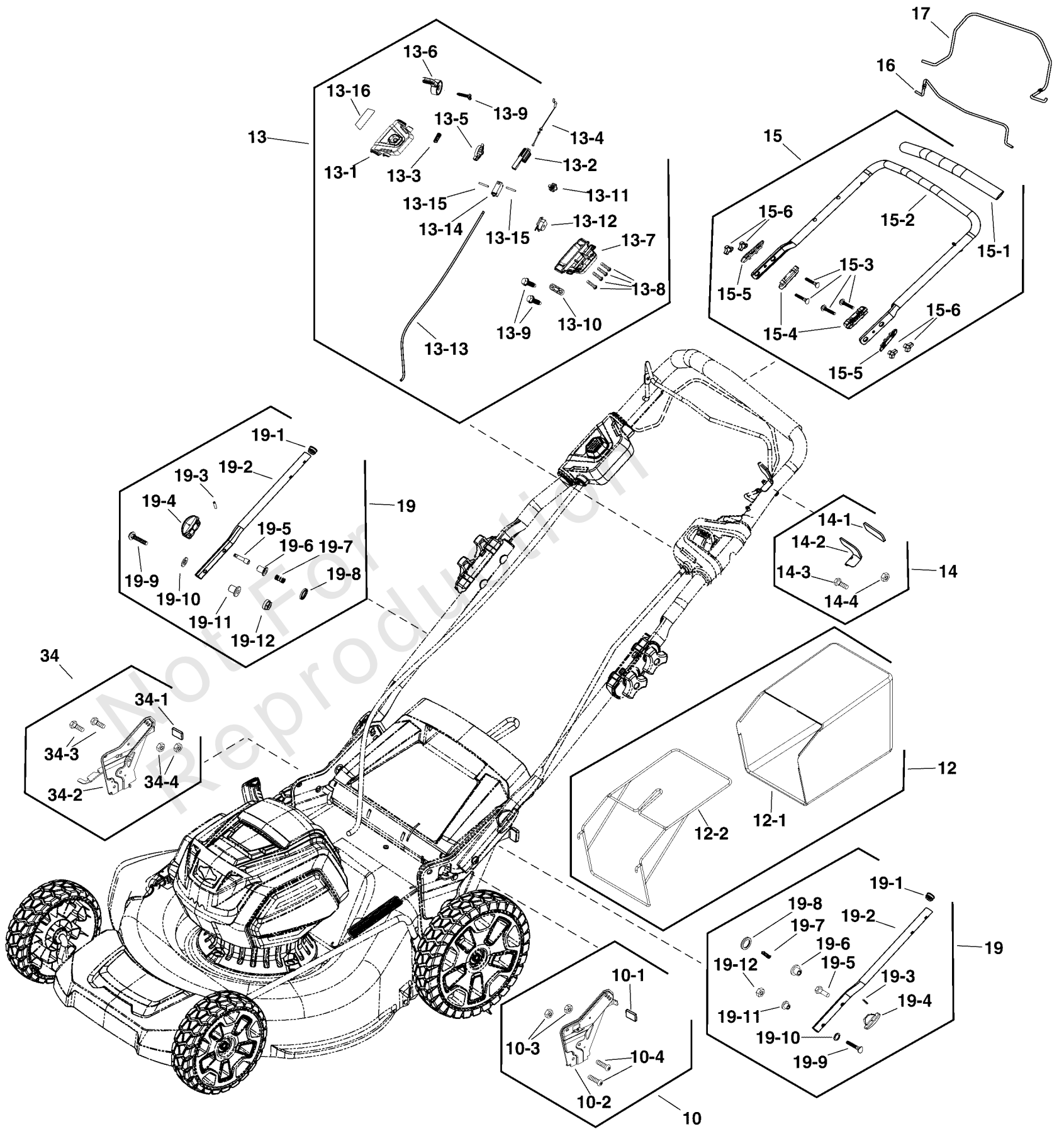

Handles Group

REF NO	PART NO	QTY	DESCRIPTION
19-12		1	NUT M8
34	771636	1	KIT, RIGHT HEIGHT ADJUST
34-1		1	BUMPER
34-2		1	RIGHT HEIGHT ADJUST
34-3		2	BOLT
34-4		2	NUT

Not For
Reproduction

Wheels & Deck Group

Note: Unless noted otherwise, use the standard torque specifications

Mfg. No: 1687914-00

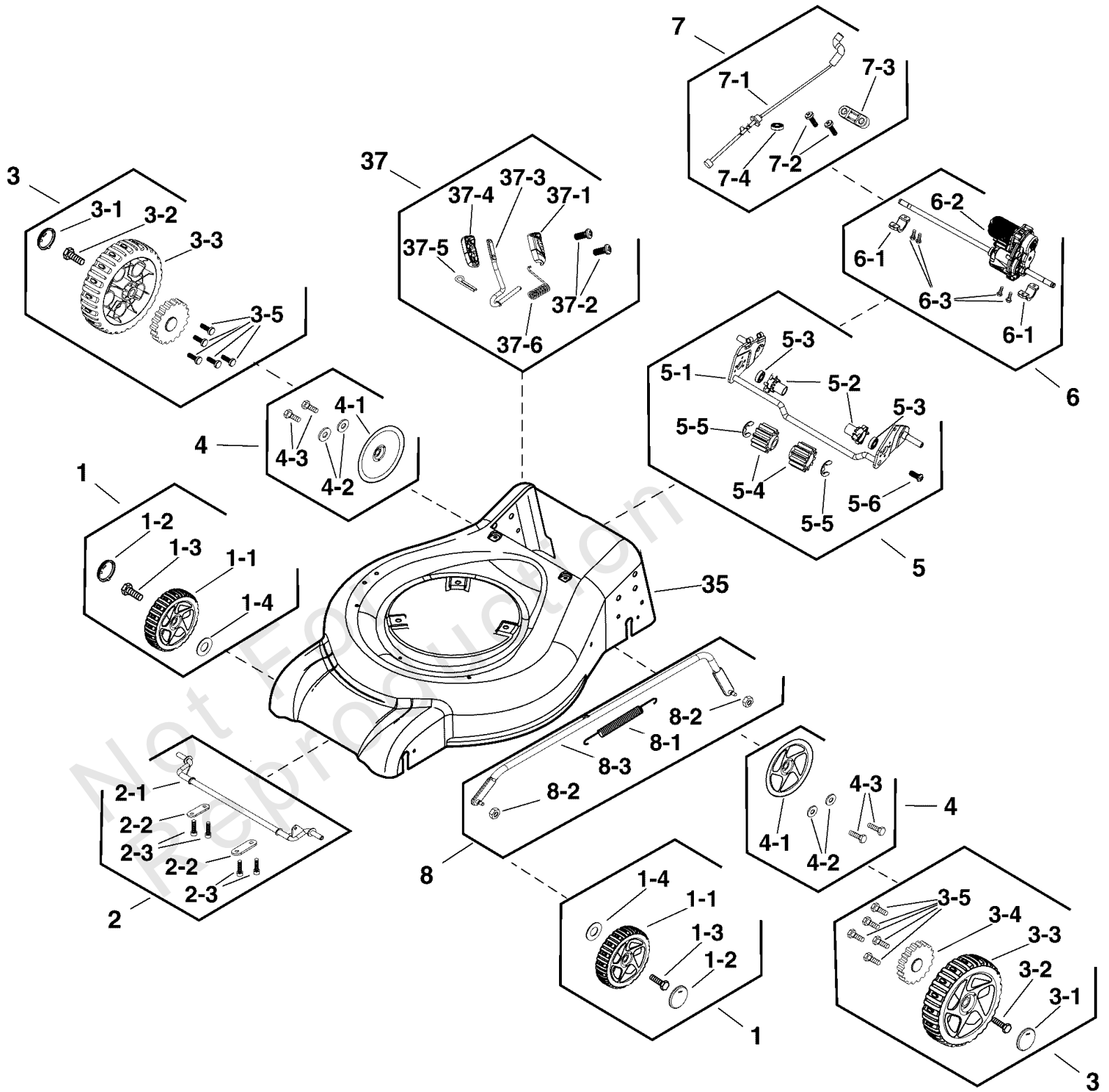

Wheels & Deck Group

REF NO	PART NO	QTY	DESCRIPTION
1	771438	1	KIT, FRONT WHEEL
1-1		1	WHEEL
1-2		1	WASHER
1-3		1	BOLT
1-4		1	WHEEL COVER
2	770186	1	KIT, FRONT AXLE
2-1		1	FRONT SHAFT
2-2		2	TABS
2-3		1	SCREW
3	771581	1	KIT, REAR WHEEL
3-1		1	WHEEL COVER
3-2		1	BOLT
3-3		1	WHEEL, 10"
3-4		1	GEAR,
3-5		5	SCREW
4	771582	1	KIT, DUST COVER
4-1		1	DUST COVER
4-2		2	GASKET 5.3
4-3		2	SCREW ST4.2-16
5	771583	1	KIT, REAR AXLE
5-1		1	SHAFT, 21" BACK
5-2		2	BEARING BLOCK
5-3		2	BEARING
5-4		2	GEAR
5-5		2	SCREW
5-6		2	SCREW ST4.2-16
6	771584	1	KIT, GEAR BOX
6-1		2	TABLET
6-2		1	GEARBOX
6-3		4	SCREW
7	771585	1	KIT, HARNESS, SELF PROPELLED
7-1		1	MOTOR CABLE
7-2		2	SCREW ST4.2-16
7-3		1	CLAMP
7-4	CM-341061577	1	GROMMENT
8	771586	1	KIT, HEIGHT ADJUST BAR
8-1		1	SPRING
8-2		2	NUT
8-3	CM-333011557A	1	CONNECTING ROD
35	771607	1	KIT, MOWER DECK
37	771608	1	KIT, HEIGHT ADJUST LEVER
37-1		1	LEFT HOUSING
37-2		2	SCREW ST4.2-12
37-3	CM-333021565B	1	ADJUST ING ROD
37-4		1	RIGHT HOUSING
37-5		1	COTTER PIN
37-6		1	SPRING

Hardware Identification & Torque Specifications

Torque Specification Chart								
FOR STANDARD METRIC MACHINE HARDWARE (Tolerance ± 20%)								
Property Class	5.6		8.8		10.9		12.9	
	Class 5.6		Class 8.8		Class 10.9		Class 12.9	
Size Of Hardware	in/lbs	Nm.	in/lbs	Nm.	in/lbs	Nm.	in/lbs	Nm.
	ft/lbs		ft/lbs		ft/lbs		ft/lbs	
M3	5.88	.56	13.44	1.28	19.2	1.80	22.92	2.15
M4	13.44	1.28	30.72	2.90	43.44	4.10	52.56	4.95
M5	26.4	2.50	60.96	5.75	5.97	8.10	7.15	9.7
M6	44.64	4.3	7.3	9.9	10.3	14	12.1	16.5
M7	5.2	7.1	12.1	16.5	16.9	23	19.9	27
M8	7.7	10.5	17.7	24	25	34	29	40
M10	15	21	35	48	50	67	59	81
M12	26	36	61	83	86.2	117	103	140
M14	42	58	101	132	136	185	162	220
M16	64	88	147	200	210	285	250	340
M18	89	121	202	275	287	390	346	470
M20	126	171	290	390	405	550	486	660
M22	169	230	390	530	559	745	656	890
M24	217	295	497	375	708	960	840	1140
M27	320	435	733	995	1032	1400	1239	1680
M30	435	590	995	1350	1401	1900	1681	2280
M33	590	800	1349	1830	1902	2580	2278	3090
M36	759	1030	1740	2360	2441	3310	2935	3980
M39	988	1340	2249	3050	3163	4290	3798	5150

Torque Specification Chart						
FOR STANDARD MACHINE HARDWARE (Tolerance ± 20%)						
Hardware Grade	No Marks		SAE Grade 5		SAE Grade 8	
	SAE Grade 2		SAE Grade 5		SAE Grade 8	
Size Of Hardware	in/lbs	Nm.	in/lbs	Nm.	in/lbs	Nm.
	ft/lbs		ft/lbs		ft/lbs	
8-32	19	2.1	30	3.4	41	4.6
8-36	20	2.3	31	3.5	43	4.9
10-24	27	3.1	43	4.9	60	6.8
10-32	31	3.5	49	5.5	68	7.7
1/4-20	66	7.6	8	10.9	12	16.3
1/4-28	76	8.6	10	13.6	14	19.0
5/16-18	11	15.0	17	23.1	25	34.0
5/16-24	12	16.3	19	25.8	29	34.0
3/8-16	20	27.2	30	40.8	45	61.2
3/8-24	23	31.3	35	47.6	50	68.0
7/16-14	30	40.8	50	68.0	70	95.2
7/16-20	35	47.6	55	74.8	80	108.8
1/2-13	50	68.0	75	102.0	110	149.6
1/2-20	55	74.8	90	122.4	120	163.2
9/16-12	65	88.4	110	149.6	150	204.0
9/16-18	75	102.0	120	163.2	170	231.2
5/8-11	90	122.4	150	204.0	220	299.2
5/8-18	100	136	180	244.8	240	326.4
3/4-10	160	217.6	260	353.6	386	525.0
3/4-16	180	244.8	300	408.0	420	571.2
7/8-9	140	190.4	400	544.0	600	816.0
7/8-14	155	210.8	440	598.4	660	897.6
1-8	220	299.2	580	788.8	900	1,244.0
1-12	240	326.4	640	870.4	1,000	1,360.0

The guides and ruler furnished below are designed to help you select the appropriate hardware.



Nut, M8

Thread Diameter (mm)

Inside Diameter (in) Threads per inch

Nut, 1/2-16



Screw, M8- 1.25 x 25

Thread Diameter (mm) Distance between threads (mm) Body Length (mm)

Body Diameter Threads per inch Body Length (in)

Screw, 1/2- 16 x 2



Standard Hardware Sizing

When a washer or nut is identified as 1/2" (M8), this is the *Nominal size*, meaning the *inside diameter* is 1/2 inch (8mm metric thread diameter); if a second number is present it represents the *threads per inch* (distance between threads).

When bolt or capscrew is identified as 1/2 - 16 x 2" (M8 - 1.25 x 50), this means the *Nominal size*, or body diameter is 1/2 inch (8mm metric thread diameter), the second number, 16, represents the *threads per inch*, (*distance between threads*). The final number is the body length of the bolt or screw, 2 inches (50mm).

NOTES

- These torque values are to be used for all hardware excluding: locknuts, self-tapping screws, thread forming screws, sheet metal screws and socket head setscrews.
- Recommended seating torque values for locknuts:
 - for prevailing torque locknuts - use 65% of grade 5 torques.
 - for flange whizlock nuts and screws - use 135% of grade 5 torques.
- Unless otherwise noted on assembly drawings, all torque values must meet this specification.

Common Hardware Types

Hex Head Capscrew



Washer



Carriage Bolt



Hex Nut

Wrench & Fastener Size Guide

1/4" Bolt or Nut Wrench—7/16"	5/16" Bolt or Nut Wrench—1/2"	3/8" Bolt or Nut Wrench—9/16"	7/16" Bolt or Nut Wrench (Bolt)—5/8" Wrench (Nut)—11/16"	1/2" Bolt or Nut Wrench—3/4"
M6 Bolt or Nut Wrench—10mm	M8 Bolt or Nut Wrench—13mm	M10 Bolt or Nut Wrench—17mm	M12 Bolt or Nut Wrench—19mm	M14 Bolt or Nut Wrench—22mm

