

# *Energizer*®



## eZV2000P USER GUIDE

# ***Energizer***<sup>®</sup>

The engine exhaust from this product contains chemicals known to cause cancer, birth defects or other reproductive harm.

©2017 *Energizer*. *Energizer* and certain graphic designs are trademarks of *Energizer* Brands, LLC and related subsidiaries and are used under license by Midland Power, Inc. All other brand names are trademarks of their respective owners. Neither Midland Power, Inc. nor *Energizer* Brands, LLC is affiliated with the respective owners of their trademarks.

EZV2000P\_UG\_EN\_2017-11-01

## **Thanks for choosing the EZV Series!**

You're excited to power up, so we'll keep this brief. Let's get started!



THIS PRODUCT MEETS ALL CERTIFICATION REQUIREMENTS FROM:



263521

## **WE'VE GOT YOU COVERED!**

Contact us by phone at 1-877-528-3772,  
email us at [support@energizergenerators.com](mailto:support@energizergenerators.com),  
or visit us online at [www.energizergenerators.com](http://www.energizergenerators.com)

## **SAVE THESE INSTRUCTIONS**

This user guide contains important instructions for your product, that should be followed during installation and maintenance of the generator.

This user guide covers the safety, operation and maintenance procedures for the EZV2000P.

All information in this publication is based on the latest product information available at the time of print.

Visit [www.energizergenerators.com](http://www.energizergenerators.com) for user guide updates and operation notices.

No part of this publication may be reproduced without written permission.

## **WARRANTY INFORMATION**

**YOU CAN REGISTER EASILY USING OUR ONLINE FORM:**

**[www.energizergenerators.com](http://www.energizergenerators.com)**

See 'Limited Warranty' for more information.

Product registration will allow you to request warranty support in the future. Product registration is required for all product support and warranty coverage.

Warranty support, operation assistance and product support is provided by Midland Power Inc., a licensed manufacturer of *Energizer* Generators. Please contact us directly for any warranty service questions.

**1-877-528-3772**

**[support@energizergenerators.com](mailto:support@energizergenerators.com)**

**[www.energizergenerators.com](http://www.energizergenerators.com)**

## TABLE OF CONTENTS

<b>1. Safety</b>	<b>1</b>
Operator Safety	1
AC Safety	2
Maintenance Safety	2
Running Generators in Parallel	3
Other Safety Tips	3
<b>2. Learn About Your Generator</b>	<b>4</b>
Component Identification	4
Control Panel	5
Control Functions	6
Make Sure You Have Everything	7
<b>3. Pre-Operation Check</b>	<b>8</b>
<b>4. Starting the Engine</b>	<b>12</b>
Starting Your Generator	13
<b>5. Generator Use</b>	<b>15</b>
Output, Overload, and Oil Alert Indicator	15
DC Applications	16
AC Applications	17
AC Parallel Operation	18
<b>6. Stopping the Engine</b>	<b>19</b>
<b>7. Maintenance</b>	<b>19</b>
Maintenance Schedule	20
Emission Control System	21
Changing the Oil	23
Cleaning The Air-Filter	24
Spark Plug Service	25
Spark Arrester Maintenance	26
Fuel Filter Maintenance	26
<b>8. Transportation &amp; Storage</b>	<b>27</b>
<b>9. Troubleshooting</b>	<b>29</b>
<b>10. Technical Specifications</b>	<b>31</b>
<b>11. Wiring Diagram</b>	<b>32</b>
<b>12. Appendix</b>	<b>33</b>
<b>13. Limited Warranty</b>	<b>34</b>

# 1. SAFETY

## **DANGER!**

**USING A GENERATOR INDOORS CAN KILL YOU IN MINUTES.**

**THE ENGINE EXHAUST FROM THIS PRODUCT CONTAINS CHEMICALS KNOWN TO CAUSE CANCER, BIRTH DEFECTS OR OTHER REPRODUCTIVE HARM.**

## 1.1 OPERATOR SAFETY

### **WARNING!**

- Always perform an oil, fuel and air filter check before starting the engine.
- Properly clean and maintain the equipment.
- Operate the generator according to instructions for safe and dependable service.
- Before operating the generator, read the user guide carefully. Otherwise, it may result in personal injuries or equipment damage.
- Never run the generator in an enclosed area to avoid harm from exhaust emissions of a poisonous carbon monoxide gas.
- Pay attention to the warning labels. The engine exhaust system will become heated during operation and remain hot immediately after the engine is stopped.
- Gasoline is a highly flammable and explosive liquid. Refuel in a well ventilated area with the engine stopped.
- Use of gasoline with an ethanol content greater than 10% can damage the engine and fuel system and will void the manufacturer's warranty.
- When refueling the generator, keep it away from cigarettes, open flames, smoke and/or sparks.
- Place the generator at least 3 feet away from buildings or other equipment during operation.
- Run the generator on a level surface. Tilting the generator may result in fuel spills.
- Know how to stop the generator quickly and understand operation of all the controls. Never permit anyone to operate the generator without proper instructions.
- Keep children, pets and machinery with rotating parts away during operation.
- Do not operate the generator in rain or snow.
- Do not allow any moisture to come in contact with the generator.



- Do not touch the spark plug while the engine is operating or shortly after the engine has been shut down.

## 1.2 AC SAFETY

### **WARNING!**

Before connecting the generator to an electrical device or power cord:

- Make sure that everything is in proper working order. Faulty devices or power cords can lead to an electrical shock.
- Turn off the generator immediately if the device begins to operate abnormally. Then disconnect the device and investigate the problem.
- Make sure that the electrical rating of the device does not exceed that of the generator. If the power level of the device is between the maximum output power and the running power of the generator, the generator should not be used for more than 30 minutes.
- Connections for standby power to a building's electrical system must be done by a qualified electrician and must comply with all applicable laws and electrical codes. Improper connections may cause serious injuries to electrical workers during a power outage, and when the utility power is restored, the generator may explode or cause fires. The generator shall be connected through transfer equipment that switches all conductors other than the equipment grounding conductor. The frame of the generator shall be connected to an approved grounding electrode.
- For power outages, permanently installed stationary generators are better suited for providing backup power to the home. Even a properly connected portable generator can become overloaded. This may result in overheating or stressing the generator components, possibly leading to a generator failure.

## 1.3 MAINTENANCE SAFETY

### **WARNING!**

- After any maintenance is performed, wash immediately using soap and clean water because repeated exposure to lubricant may cause skin irritation.
- Do not clean the filter element with flammable liquids like gasoline because an explosion may occur.
- Turn off the engine before performing any maintenance. Otherwise it can cause severe personal injury or death.
- Allow the generator set to cool down before performing any

maintenance.

- Always wear safety glasses when cleaning the generator set with air.
- Do not clean the generator set with a pressure washer because it can cause damage to the generator set.
- When working with batteries, ventilate the area, use safety glasses, do not smoke. Always disconnect the negative first and reconnect it last.
- Use rubber gloves when coming into contact with engine oil.
- Always stop the generator set before removing the oil filler cap.
- Only qualified maintenance personnel with knowledge of fuels, electricity, and machinery hazards should perform maintenance procedures.
- Lubricate all exposed metal parts regularly. See chapter 7.1 for maintenance schedule.

## 1.4 RUNNING GENERATORS IN PARALLEL

### **WARNING!**

- Only connect in parallel with an *Energizer*® EZV2000P or EZV3200P with the approved parallel cable (sold separately). Attempting to connect other brands or models will void your warranty and could cause bodily injury.

## 1.5 OTHER SAFETY TIPS

### **WARNING!**

- To avoid breathing in poisonous carbon monoxide from the exhaust gases, adequate ventilation should be provided if the generator set is running in a partially enclosed space.
- If the generator set is stored outdoors, check all the electrical components on the control panel before each use. Moisture can damage the generator and can lead to an electric shock.
- Generators vibrate in normal use. During and after the use of the generator, inspect the generator as well as extension cords and power supply cords connected to it for damage resulting from vibration. Have damaged items repaired or replaced as necessary. Do not use plugs or cords that show signs of damage such as broken or cracked insulation or damaged blades.
- If you start to feel sick, dizzy, or weak after the generator has been running, move to fresh air RIGHT AWAY. See a doctor. You could have carbon monoxide poisoning.

## 2. LEARN ABOUT YOUR GENERATOR

This section will show you how to identify key parts of your generator. Going over the terminology below will make sure we're on the same page.

### 2.1 COMPONENT IDENTIFICATION

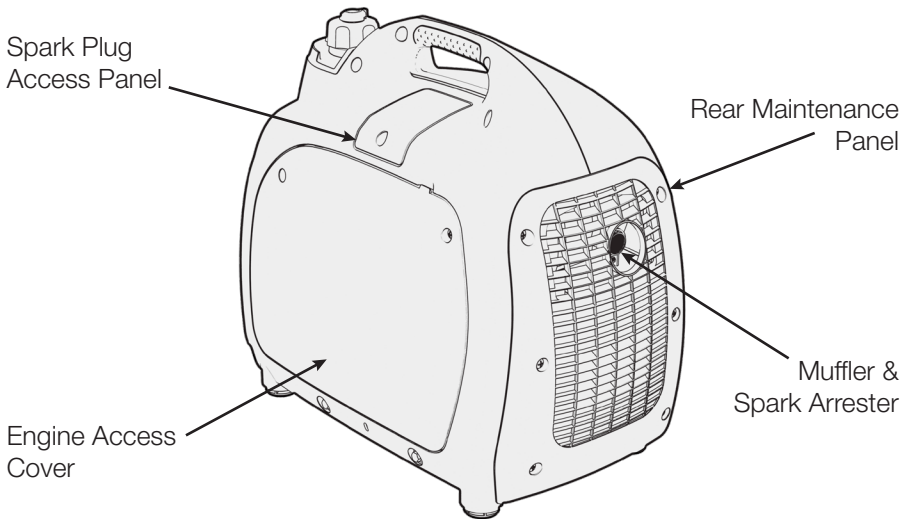
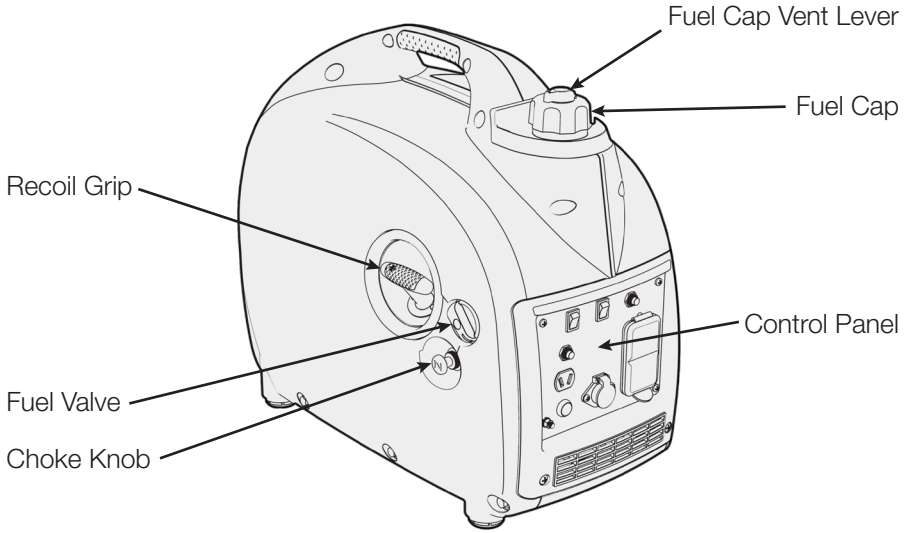

## 2.2 CONTROL PANEL

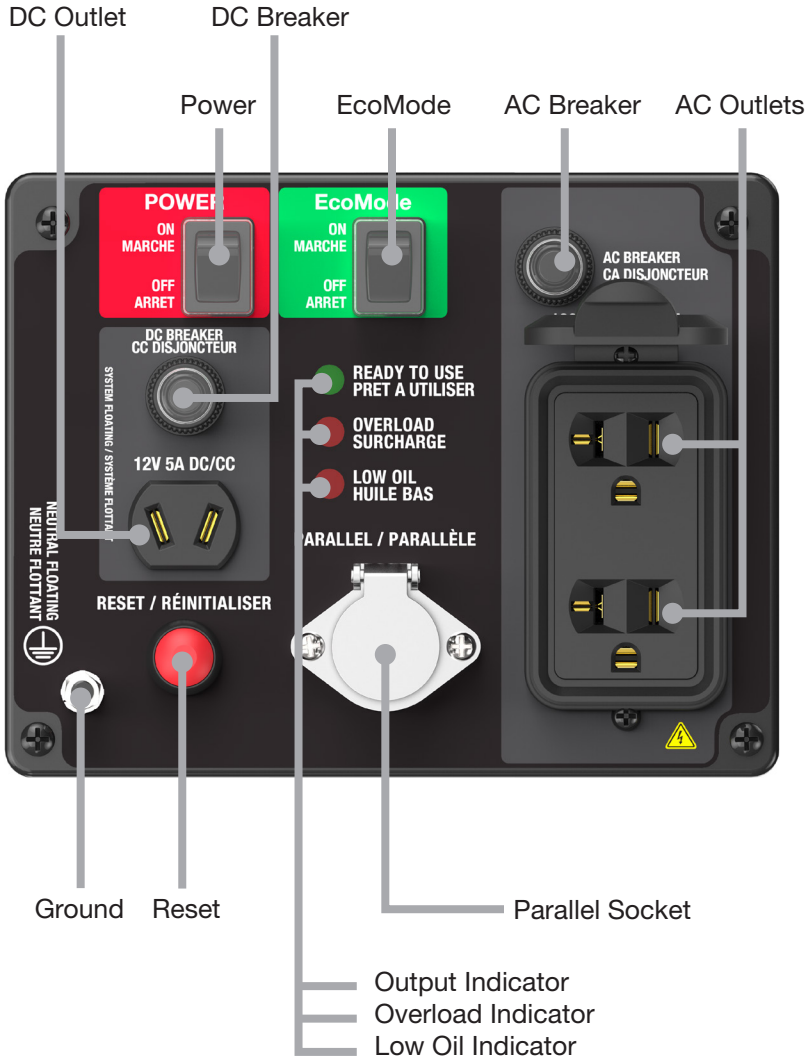

## 2.3 CONTROL FUNCTIONS

### EcoMode (Economy Control Switch)

- Turn EcoMode ON to minimize fuel consumption. In this mode the engine will dynamically meet the demand of the electrical load and will automatically go into an idle state if all loads are disconnected.
- Before connecting or removing a high load device to the generator, turn EcoMode OFF until that device has reached running power.
- When EcoMode is OFF, the engine runs at full speed.

### Reset Button

- If the red overload indicator light is on, press and hold the reset button for 1 second until the overload indicator light turns off and the green output indicator light turns on. This will recover generator output without shutting down the engine.
- If the generator is running normally, the RESET button will have no effect.

#### **NOTE**

- The RESET button is available a maximum of 5 times for every full start of the generator. Shut down the generator and restart using the power switch to refresh the start times.

### Output and Overload Indicator

- In normal operation, the green output indicator light (READY TO USE) will remain on.
- If the generator is overloaded (producing more than 1600W) or a connected appliance has short-circuited, the output indicator light will turn off and the overload indicator light will turn on.

### AC Parallel Sockets

- These sockets allow two of the exact same generator model to be connected in parallel. The parallel cable is an optional accessory, please contact your dealer, visit us online, or call 1-877-528-3772 to purchase.

## AC Circuit Breakers

- While the generator is running, the breakers should be in the ON position.
- If the current has exceeded its limits the breaker will automatically pop out to the OFF position. Reduce the electrical load on the generator and push the button back to the ON position.

## DC Circuit Breakers

- The DC circuit breaker automatically shuts off when the charging circuit is overloaded.
- If the current has exceeded its limits the breaker will automatically pop out to the OFF position. Reduce the electrical load on the generator and push the button back to the ON position.

## Low Oil Indicator Light

- The oil alert system is designed to prevent engine damage caused by an insufficient amount of oil in the crankcase. Before the oil level in the crankcase reaches an unsafe limit, the oil alert system will automatically shut down the engine (the power switch remains in the ON position).
- If the oil alert system shuts down the engine, the low oil indicator light (red) will turn on. Check the engine oil level.

## 2.4 MAKE SURE YOU HAVE EVERYTHING

Make sure your generator has everything listed in the table below.

Part Name	Quantity
Inverter Generator	1
User Guide	1
Spark Plug Wrench - Sleeve	1
Spark Plug Wrench - Bar	1
Multi Screwdriver	1
DC Charging Cable	1
Oil Transfer Tool	1

### 3. PRE-OPERATION CHECK

Set the generator on a level surface and the power switch to OFF.

#### 3.1 PREPARE THE AIR CLEANER

Clean and oil the air filter before your first use. Check the maintenance schedule for a complete cleaning guide.

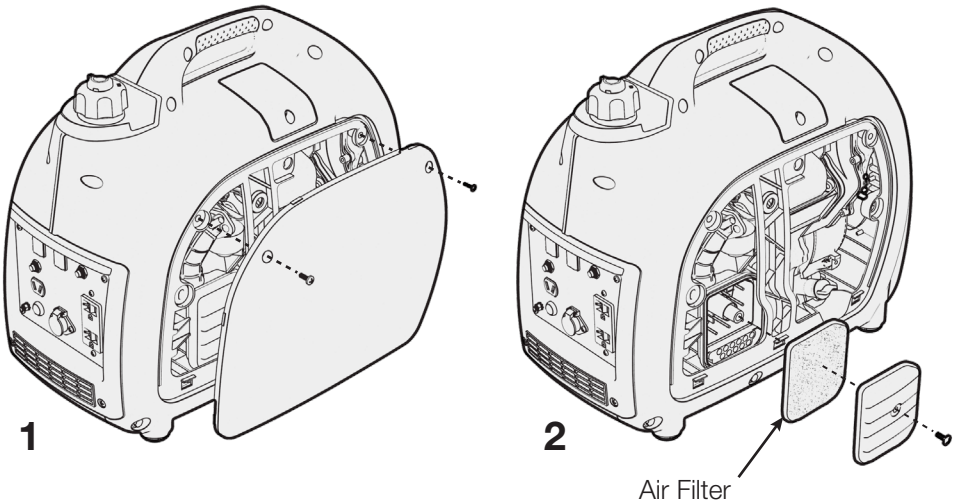

1. Unscrew and remove the engine access panel.
2. Unscrew the air filter cover and remove the filter.
3. Clean the air filter with soap and water or solvent and squeeze dry.
4. Soak in clean engine oil.
5. Squeeze out all excess oil and reinstall. Replace the filter if it is damaged.

#### **NOTE**

- Running the engine without the air filter will quickly degrade the engine

### 3.2 CHECK THE OIL LEVEL

1. Place the generator on a level surface.
2. Unscrew and remove the engine access panel. This may require some force to loosen the snapfits.
3. Unscrew the oil cap and clean the dipstick.
4. Reinsert the oil cap without screwing it back in. Remove the cap and examine the oil level on the dipstick.
5. If the level is at or below the minimum oil level marked on the dipstick, refill to the maximum oil level mark.
6. Reinsert the oil cap and tighten securely. Replace the engine access panel and screws.

#### NOTE

- SAE 10W-30 is recommended for general use.
- Oil Capacity: 0.35L / 0.09 Gal.
- DO NOT OVERFILL.

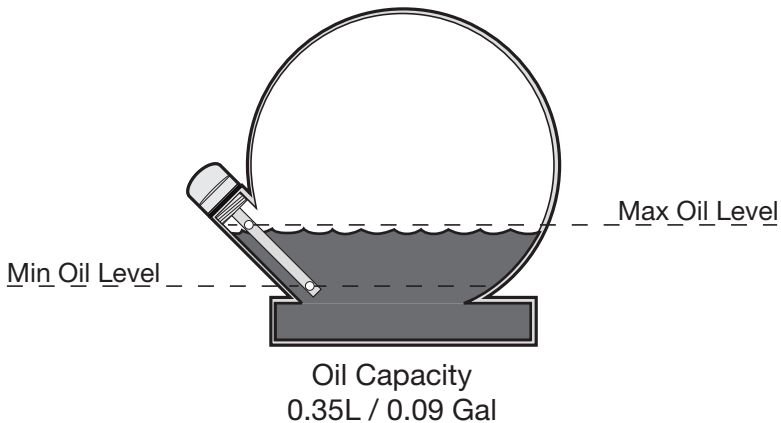
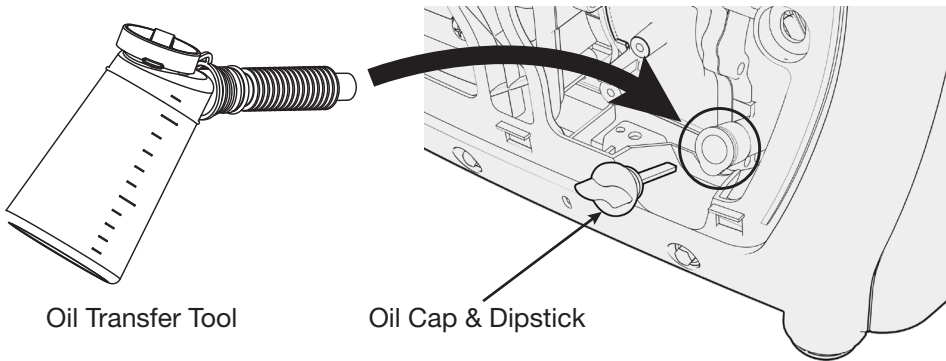



## Effective Viscosity Range of Engine Oils

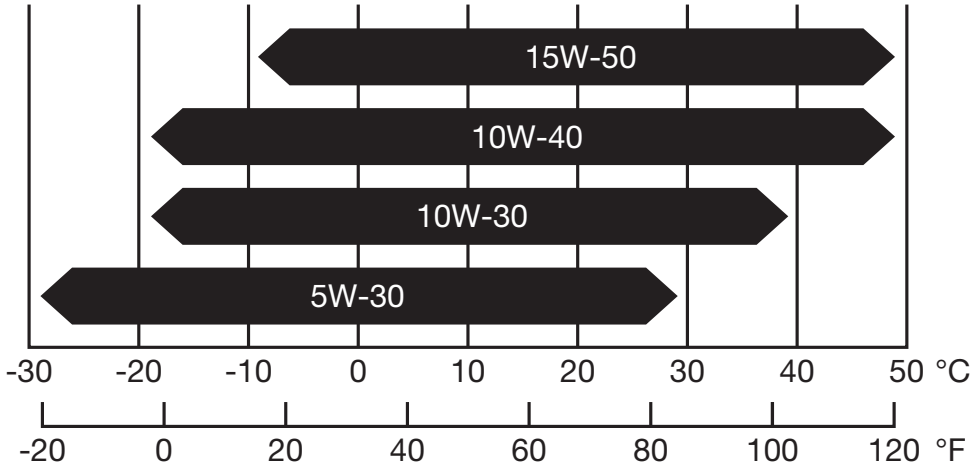

### NOTE

- Do not tilt the generator when adding engine oil. This could result in overfilling and damage to the engine.
- Use high quality 4-stroke engine oil, certified to meet or exceed API standard SG, SF, SAE ratings with strong detergents. Using non-detergent or 2-stroke oil could shorten the engine's working life.
- Do not mix different engine oils.
- Handle and store the engine oil with care, avoid getting dirt or dust into the engine oil.
- Before the engine oil falls below the safety margin, the low oil alert system will automatically shut off the engine. The low oil light will turn on.
- To avoid the inconvenience of unexpected engine shutoff, check the engine oil level as often as possible.

### 3.3 CHECK THE FUEL LEVEL

#### NOTE

- Use of gasoline with an ethanol content greater than 10% can damage the engine and the fuel system and will void the manufacturer's warranty.
- Only use unleaded gasoline (Pump Octane 91 or higher).
- Never use stale or contaminated gasoline, or an oil/gasoline mixture.
- Avoid getting dirt or water into the fuel tank.
- Do not use a mixture of gasoline containing methanol. This will cause serious damage to the engine.

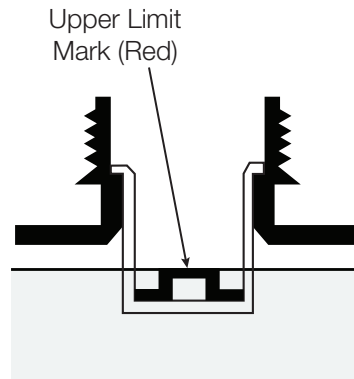
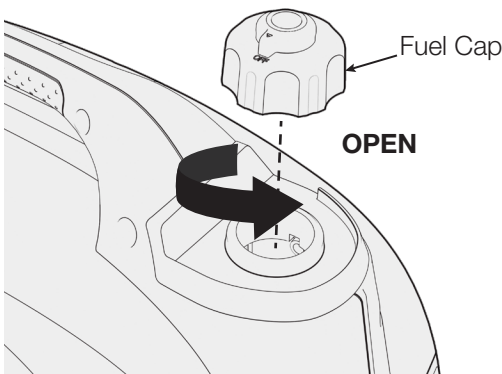

Fuel Capacity: 3.4L  
(0.9 US Gal)

#### WARNING!

**GASOLINE IS HIGHLY FLAMMABLE AND EXPLOSIVE UNDER CERTAIN CONDITIONS. REFUEL**

**IN A WELL-VENTILATED AREA WITH THE ENGINE STOPPED. DO NOT SMOKE OR ALLOW OPEN FLAMES OR SPARKS IN THE AREA WHERE THE GENERATOR IS BEING REFUELED OR WHERE GASOLINE IS STORED. DO NOT OVERFILL THE TANK. BE CAREFUL NOT TO SPILL FUEL WHEN REFUELING. WIPE UP ANY SPILLED GASOLINE AND LET THE AREA DRY BEFORE STARTING THE ENGINE.**

**GASOLINE SUBSTITUTES SUCH AS GASOHOL ARE NOT RECOMMENDED. THEY MAY BE HARMFUL TO THE FUEL SYSTEM COMPONENTS.**

## 4. STARTING THE ENGINE

#### DANGER! CARBON MONOXIDE

**USING A GENERATOR INDOORS WILL KILL YOU IN MINUTES.**

**GENERATOR EXHAUST CONTAINS HIGH LEVELS OF CARBON MONOXIDE (CO), A POISONOUS GAS YOU CANNOT SEE OR SMELL. IF YOU CAN SMELL THE GENERATOR EXHAUST YOU ARE BREATHING CO. EVEN IF YOU CANNOT SMELL THE EXHAUST, YOU COULD BE BREATHING CO.**

**NEVER USE A GENERATOR INSIDE A HOME, GARAGE, CRAWLSPACE, OR OTHER PARTLY ENCLOSED AREA, DEADLY LEVELS OF CARBON MONOXIDE CAN BUILD UP IN THESE AREAS. USING A FAN OR OPENING WINDOWS AND DOORS WILL NOT SUPPLY ENOUGH FRESH AIR.**

**ONLY USE A GENERATOR OUTDOORS AND FAR AWAY FROM OPEN WINDOWS, DOORS, AND VENTS. THESE OPENINGS CAN PULL IN GENERATOR EXHAUST. EVEN WHEN YOU USE A GENERATOR CORRECTLY, CO MAY LEAK INTO THE HOME. ALWAYS USE A CO ALARM IN YOUR HOME.**

**IF YOU START TO FEEL SICK, DIZZY, OR WEAK AFTER THE GENERATOR HAS BEEN RUNNING, MOVE TO FRESH AIR RIGHT AWAY AND SEEK MEDICAL ATTENTION. YOU COULD HAVE CARBON MONOXIDE POISONING. NEVER RUN THE GENERATOR IN AN ENCLOSED OR EVEN PARTIALLY ENCLOSED AREA WHERE PEOPLE MAY BE PRESENT.**

## 4.1 STARTING YOUR GENERATOR

### WARNING!

BEFORE USING THE GENERATOR, A GROUND WIRE MUST BE CONNECTED TO THE GROUND TERMINAL. THE GROUND TERMINAL IS LOCATED ON THE FRONT PANEL. BEFORE USING THE GROUND TERMINAL CONSULT A QUALIFIED ELECTRICIAN.

### NOTE

- Before starting the engine disconnect all devices from the outlets on the front panel.
- Return the starter grip slowly by hand, do not let it snap back.

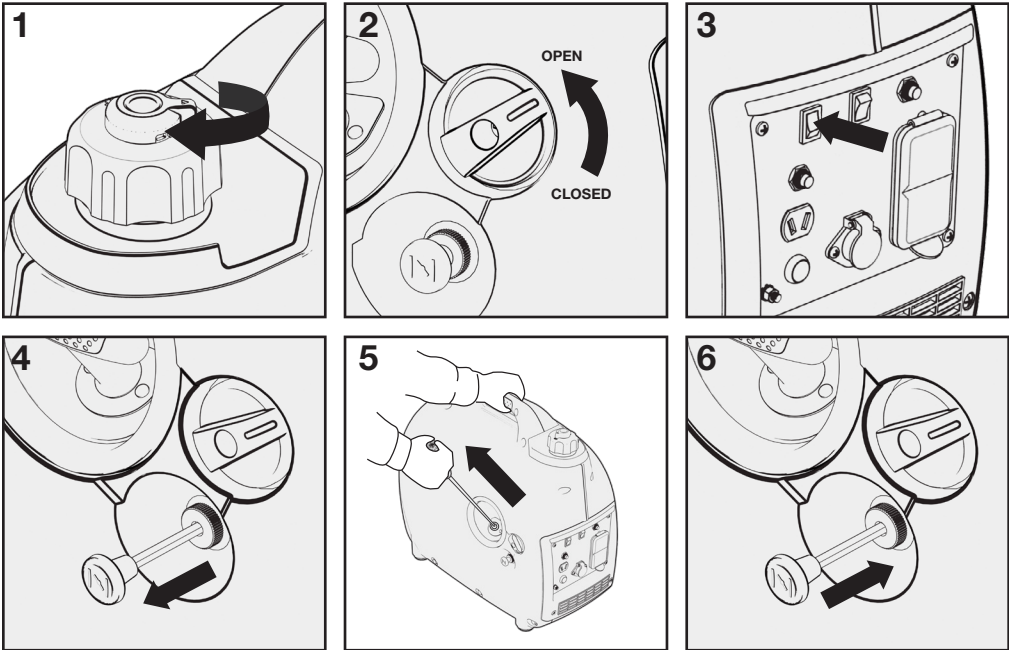

- Do not pull out the choke knob when the engine is hot or ambient air temperature is high
1. Rotate the fuel cap vent lever to ON.
  2. Rotate the fuel valve to the OPEN position.
  3. Turn the power switch to the ON position.
  4. If the engine is cold pull the choke lever fully out.
  5. Pull the starter slowly until you feel it engage then pull quickly. Repeat until the generator starts.
  6. When the engine warms up push the choke fully in. The choke is used to provide the proper air-fuel mixture when the engine is cold.

## Carburetor Modification for High Altitude Operation

- At high altitudes, the standard carburetor air-fuel mixture will be too rich. Fuel consumption will increase and performance will decrease. A very rich mixture will also foul the spark plug and cause hard starting.
- If using the generator at high altitudes, change the main-nozzle or adjust the idling-screw of the carburetor. If always operating the generator at altitudes above 1,000 meters, contact an authorized service center to have the carburetor modified.
- Conversely, if the carburetor has been modified for high altitude operation, the air-fuel mixture will be too lean for low altitude use. Operation at low altitude may cause the engine to overheat and result in serious engine damage. In this case the carburetor needs to be returned to its original specifications.
- Generator output power should be modified according to the altitude and ambient temperature. See more details on the correction factors in Chapter 12 - Appendix.

# 5. GENERATOR USE

## WARNING!

- Be sure to ground the generator when the connected electrical appliance is grounded.
- Do not connect to the building’s electrical system. Doing so may result in electrical shocks and fire.
- To prolong engine life, do not exceed the rated running wattage. Do not connect an extension to the exhaust pipe.
- When an extension cable is required, be sure to use a tough rubber sheathed flexible cable (according to IEC245 or equivalent standards). The maximum length of the extension cable: 60 meters (196 feet) for cable of 1.5mm<sup>2</sup> (15.5 gauge); 100 meters (328 feet) for cable of 2.5mm<sup>2</sup> (13.25 gauge).
- Keep away from other electric cables or wires.

### 5.1 OUTPUT, OVERLOAD, AND OIL ALERT INDICATOR

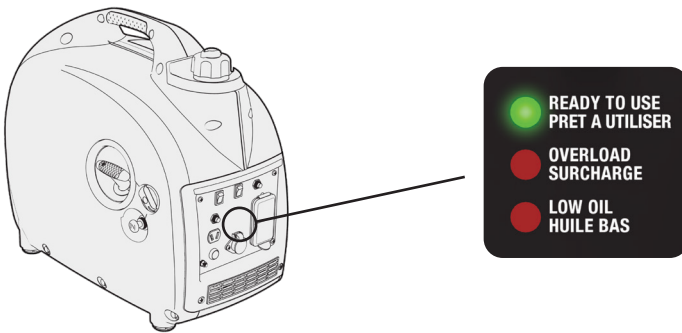

Light (Solid)		Description	
Green	Output Indicator	ON	Indicates normal operation
		OFF	Indicates a problem or unit is off
Red	Overload Indicator	ON	Indicates overload or problem with connected appliances, disconnect any appliances and press and hold the reset button (1s).
		OFF	Indicates normal operation
Red	Low Oil Indicator	ON	Indicates insufficient oil in the crankcase
		OFF	Indicates normal operation

## 5.2 DC APPLICATIONS

The DC receptacle may be used for charging 12V batteries only. In DC operation, turn EcoMode OFF.

### NOTE

- The DC receptacle can be used while the AC power is in use. If used at the same time, be sure not to exceed the total power for AC and DC. (AC: 1600W, DC: 5A)
- Motor vehicles require more than their rated wattage when starting.

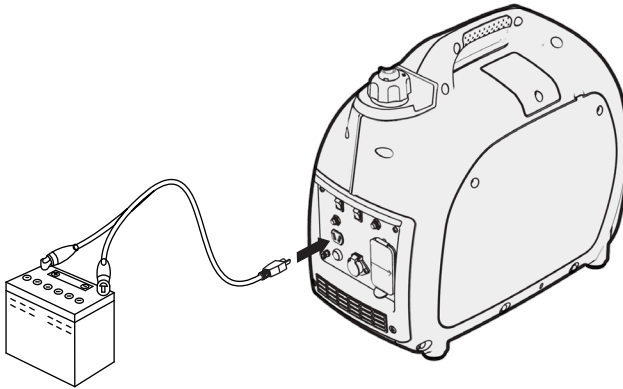

### Connecting the charging cable:

1. If connecting to a vehicle battery, disconnect the vehicle battery ground cable from the negative (-) battery terminals.
2. Connect the DC outlet to the battery terminals using the included charging cable. Connect red lead to positive (+) battery terminal and black lead to negative (-) battery terminal.
3. Turn EcoMode OFF, and start the generator.

### NOTE

- Do not start the vehicle engine when the generator is still connected to the battery, this will damage the generator.
- System floating for DC output.

### Disconnecting the charging cable:

1. Stop the engine.
2. Disconnect the black lead from the negative (-) battery terminal, and the red lead from the positive (+) battery terminal.
3. Reconnect the vehicle battery ground cable.

## 5.3 AC APPLICATIONS

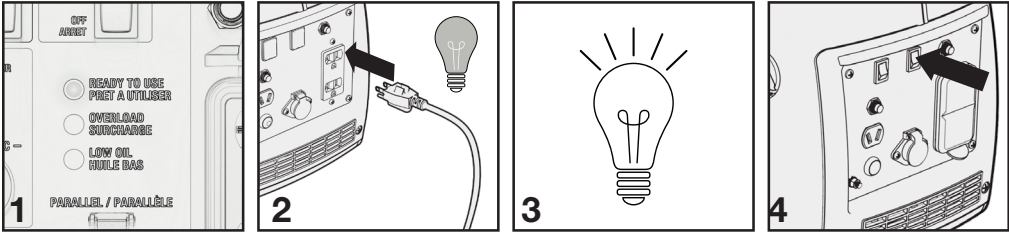

1. Start engine and make sure the output indicator light (READY TO USE) is on.
2. Confirm all electrical appliances are switched off, and connect the appliance plugs to the generator receptacle.
3. Turn on the appliances.
4. Turn EcoMode ON.

### NOTE

- Confirm all electrical appliances are in good working condition before connecting them to the generator. If an electrical appliance becomes abnormal, sluggish, or stops suddenly, shut off the generator engine immediately, and disconnect the appliance.
- Most appliances require more than their rated wattage upon startup.
- For continuous operation do not exceed the rated output of the generator (1600W).
- Do not run a maximum output of 2000W for 30 minutes or longer.
- The grounding system is not connected to the AC neutral wire.
- Neutral floating for AC system.



## 5.4 AC PARALLEL OPERATION

### **WARNING!**

**YOU CAN ONLY CONNECT AN ENERGIZER® EZV2000P OR EZV3200P IN PARALLEL WITH THE APPROVED PARALLEL CABLE. ATTEMPTING TO CONNECT A DIFFERENT BRAND OR MODEL IN PARALLEL WITH YOUR GENERATOR WILL VOID YOUR WARRANTY AND COULD CAUSE BODILY HARM.**

**DO NOT START THE GENERATORS BEFORE CONNECTING THE PARALLEL CABLE. IF THE CABLE IS CONNECTED WHILE ONE GENERATOR IS RUNNING IT WILL BE OVERLOADED AND THE 'RESET' BUTTON WILL NEED TO BE PRESSED.**

**IF THE OVERLOAD INDICATOR LIGHT STAYS ON AFTER RESETTING THE GENERATOR STOP THE ENGINE, WAIT FOR 5 MINUTES THEN RESTART IT.**

### **NOTE**

- For continuous operation do not exceed the combined rated power.
- At max output the generators must not run longer than 30 min.
- Stop the engine before connecting or removing the parallel cable.
- For single unit operation the parallel cable must be removed.

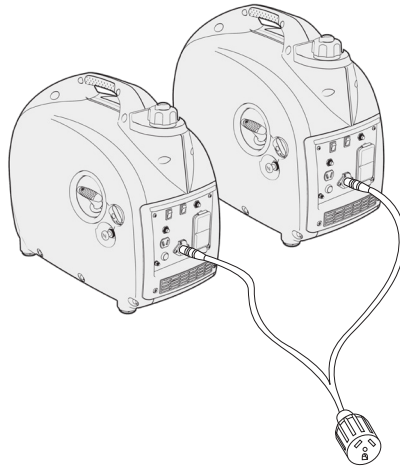

1. Make sure both generators are OFF.
2. Connect the terminals of the AC parallel cable to the parallel socket of each generator.
3. Start each engine according to 'Starting the Engine'.
4. Confirm appliances are turned off, then connect the appliance to the parallel cable.
5. Turn on the appliance.

## 6. STOPPING THE ENGINE

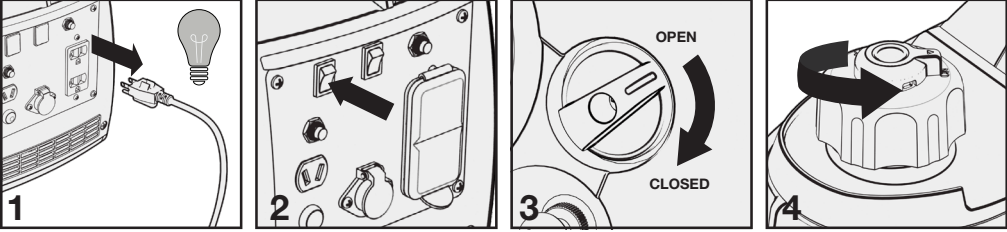

Normal Operation:

1. Switch off the connected electrical appliances, and disconnect from the generator.
2. Turn the power switch to the OFF position.
3. Turn the fuel shutoff to the CLOSED position.
4. Turn the fuel cap vent lever to the OFF position.

### NOTE

- Make sure the fuel cap vent lever and engine switch are in the OFF position when stopping, transporting, and storing the generator.
- To stop the engine in an emergency, turn the power switch OFF immediately.

## 7. MAINTENANCE

Proper maintenance keeps your generator in the best operating condition by ensuring safe, economical and trouble-free operation. Only use genuine parts and recommended fluids to replace the worn components. Improper maintenance may cause the generator to malfunction and can lead to serious injury. Contact customer support if you have any maintenance questions.

### General Inspection Tips

- Look for fuel leaks around the fuel tank, fuel hose, and fuel valve. Close the fuel valve and repair leaks immediately.
- Look and listen for exhaust leaks while the engine is running. Have all the leaks repaired before continuing operation.
- Check for dirt and debris and clean as necessary .
- Check the engine oil level and add oil as necessary.

## 7.1 MAINTENANCE SCHEDULE

Maintain the generator according to the maintenance schedule in this section. For commercial use, utilize hours of operation to determine proper maintenance intervals.

### NOTE

- Service more frequently when used in dusty areas.
- These items should be serviced by an authorized service center, unless you have the proper tools and are mechanically proficient. Refer to manual for service procedures.

Item	Task	Each Use	Every 20 Hours	Every 50 Hours	Every 100 Hours	Every 300 Hours
Generator	General Inspection	•				
Engine Lubricants	Inspect Oil Level	•				
	Replace		•*		•	
Air Filter	Inspection	•				
	Cleaning			•		
Sediment Cup	Cleaning			•		
Spark Plug	Inspection & Cleaning				•	
	Replacement					•
Valve Clearance	Inspection & Adjusting					•
Combustion Chamber	Inspection & Adjusting					•
Fuel Tank and Strainer	Cleaning					•
Fuel Line	Cleaning	Every two months (replace if necessary)				
Exposed Metal Parts	Lubricate with oil	After every use and especially before storage				

\* For first use of the generator.

## 7.2 EMISSION CONTROL SYSTEM

### Emission Source

Exhaust gas contains carbon monoxide, nitrogen oxides (NO<sub>x</sub>) and hydrocarbons. It is very important to control the emissions of NO<sub>x</sub> and hydrocarbons as they are a major contributor to air pollution. Carbon monoxide is a poisonous gas. The emission of fuel vapors is a source of pollution as well. The generator engine utilizes a precise air-fuel ratio and emission control system to reduce the emissions of carbon monoxide, NO<sub>x</sub>, hydrocarbons and evaporative fuel emissions.

### Regulation

Your engine has been designed to meet current Environmental Protection Agency (EPA) and the California Air Resource Board (CARB) clean air standards. The regulations dictate that the manufacturer provides operation and maintenance standards regarding the emission control systems. Tune up specifications are provided in the Specifications section and a description of the emission control system may be found in the appendix to this manual. Adherence to the following instruction will ensure your engine meets the emission control standards.

### Modification

Modification of the emission control system may lead to increased emissions. Modification is defined as the following:

- Disassembling or modifying the function or parts of the intake, fuel or exhaust system.
- Modifying or destroying the speed governing function of the generator.

### Engine faults that may affect emission

Any of the following faults must be repaired immediately. Consult with your authorized service centre for diagnosis and repair:

- Hard starting or shut down after starting.
- Unstable idle speed.
- Shut down or backfire after applying an electrical load.
- Backfire or after fire.
- Black smoke and/or excessive fuel consumption.

## **Replacement parts and accessories**

The parts making up the emission control system in your product's engine have been specifically approved and certified by the regulatory agencies. You can trust that the replacement parts supplied by customer service have been manufactured to the same production standard as the original parts. The use of replacement parts or accessories which are not designed by – may negatively affect the engine emission performance. Therefore only use replacements parts and accessories from a qualified service centre to guarantee that the replacement products will not adversely affect emission performance.

Replacement parts other than those from an authorized service centre will void the warranty.

## **Air Index (Models certified for sale in California)**

An Air Index Information label is applied to engines certified to an emission durability time period in accordance with the requirements of the California Air Resources Board.

The bar graph is intended to provide you, our customer, the ability to compare the emissions performance of available engines. The lower the Air Index, the less pollution.

The durability description is intended to provide you with information relating to the engine's emission durability period. The descriptive term indicates the useful life period for the engine's emission control system.

The Air Index Information hang tag must remain on the generator until it is sold. Remove the hang tag before operating the generator.

## 7.3 CHANGING THE OIL

### WARNING!

USED MOTOR OIL CAN CAUSE SKIN IRRITATIONS IF LEFT IN LONG-TERM CONTACT WITH SKIN. THOROUGHLY WASH OFF USED OIL AS SOON AS POSSIBLE WITH SOAP AND WATER.

DO NOT DISPOSE OF USED OIL IN DRAINS OR ON SOIL. LOCAL SERVICE SHOPS PROVIDE ENVIRONMENTALLY-FRIENDLY DISPOSAL METHODS.

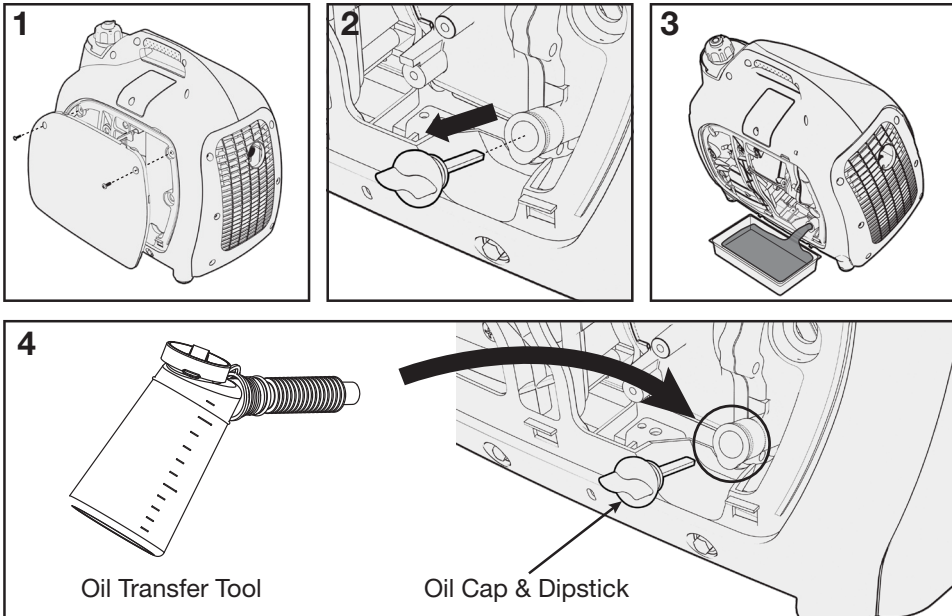

Drain the oil rapidly and completely while the engine is still warm.

1. Loosen the two screws of the engine access panel and remove the panel.
2. Unscrew the oil filler cap.
3. Place a drain pan below the generator and tip the generator until oil flows into the pan. Let all used oil drain out.
4. Refill with the recommended oil and check the level. Do not overfill.
5. Reinstall the oil dipstick and tighten it.
6. Reinstall the engine access cover.

## 7.4 CLEANING THE AIR-FILTER

### **WARNING!**

**USING GASOLINE OR OTHER FLAMMABLE SOLVENTS CAN CAUSE A FIRE OR EXPLOSION. DO NOT OPERATE THIS PRODUCT WITHOUT AN AIR FILTER.**

A dirty air filter will restrict air flow into the carburetor. Clean and maintain the air filter regularly, especially in dusty areas.

### **NOTE**

**NEVER RUN THE GENERATOR WITHOUT AN AIR FILTER, DOING SO WILL QUICKLY DEGRADE THE ENGINE.**

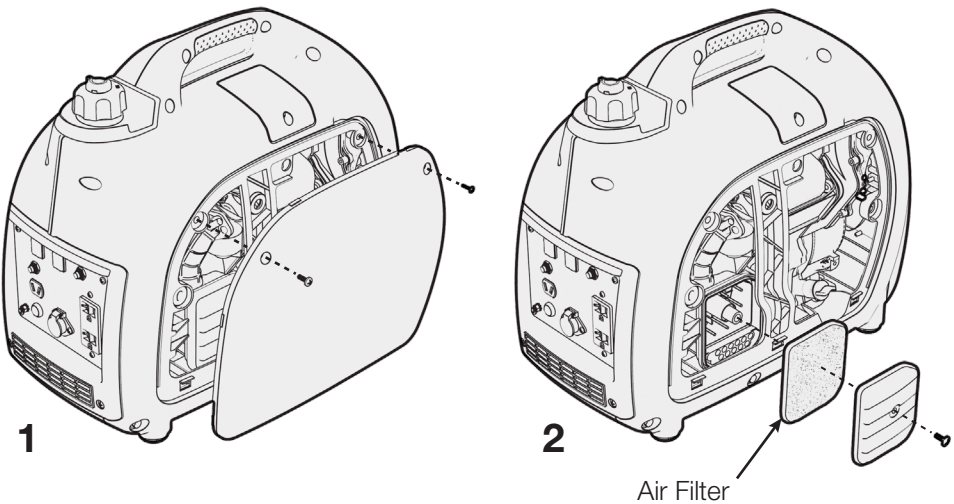

1. Unscrew and remove the engine access panel.
2. Unscrew and remove the air filter assembly.
3. Remove the foam filter.
4. If the foam element is dirty, clean it in warm soapy water, rinse, and allow it to dry thoroughly, or clean in non-flammable solvent and allow to dry.
5. Dip the foam element in clean engine oil, then squeeze out all excess oil. The engine will smoke when started if too much oil is left in the filter.
6. Wipe dirt from the air filter assembly and reinstall into the unit.

## 7.5 SPARK PLUG SERVICE

### NOTE

**DO NOT RINSE SPARK PLUG IN WATER. FOLLOW GUIDELINES AND BE CAREFUL NOT TO OVERTIGHTEN THE SPARK PLUG.**

Recommended spark plug: **BPR6HS**

Check the spark plug gap and clean the carbon deposits at the bottom of the spark plug.

**TIGHTEN 1/2 TURN WHEN INSTALLING A NEW SPARK PLUG.**

**TIGHTEN 1/8 TO 1/4 TURN WHEN RE-INSTALLING AN OLD SPARK PLUG.**

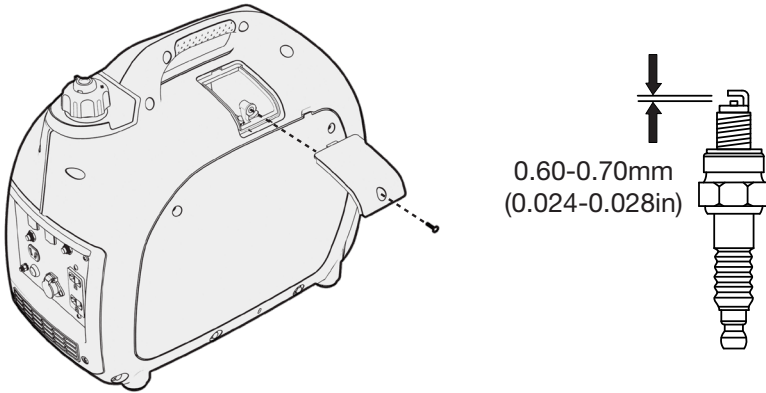

1. Remove the spark plug access panel.
2. Remove the spark plug cap.
3. Remove the spark plug with the spark plug spanner.
4. Visually inspect the spark plug. Replace with a new one if the insulation is cracked or chipped. Clean with a wire brush if the spark plug is reused.
5. Measure the spark plug gap with a feeler gauge. The normal value is: 0.6-0.7mm (0.024- 0.028in). Adjust the gap by carefully bending the electrode.
6. Carefully reinstall the spark plug by hand, to avoid cross-threading. A new spark plug should be tightened 1/2 turn with a spanner. A used spark plug should be tightened 1/8 to 1/4 turn with spanner.
7. Reinstall the spark plug cap.
8. Reinstall the spark plug maintenance cover.

### NOTE

- The spark plug must be securely tightened or it could cause the spark plug to heat up, enough to damage the engine.
- Never use a spark plug with an improper heat range.



## 7.6 SPARK ARRESTER MAINTENANCE

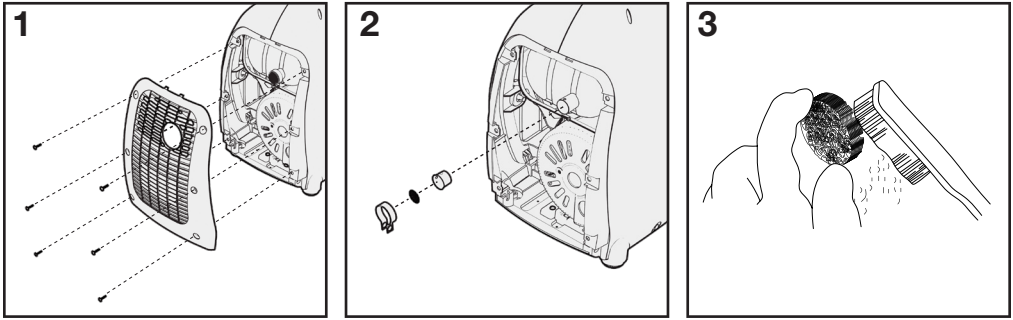

1. Loosen 6 screws and remove the muffle guard.
2. After the engine has cooled down remove the spark arrester from the muffler.
3. Use a brush to remove carbon deposits from the spark arrester. If the spark arrester is worn down, replace it.
4. Reinstall the spark arrester and muffle guard.

## 7.7 FUEL FILTER MAINTENANCE

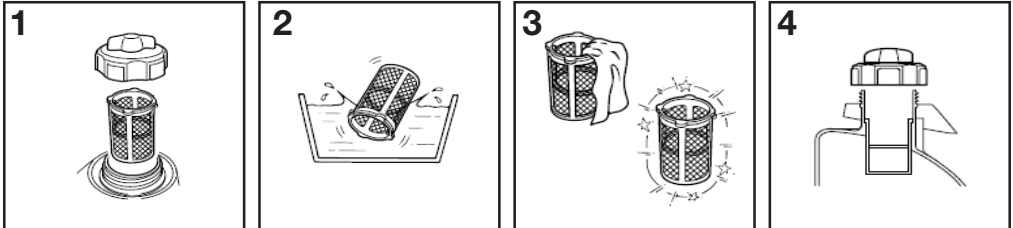

1. Remove the fuel cap and filter.
2. Clean the filter with solvent.
3. Wipe the filter.
4. Reinsert the filter.

# 8. TRANSPORTATION & STORAGE

## Transporting the Generator

1. Do not overfill the fuel tank (No residual fuel on the neck of tank).
2. Do not use the generator in the vehicle. The generator should ONLY be used while in a well ventilated area.
3. Avoid exposing the generator to prolonged direct sunlight while in an enclosed vehicle. The high temperature inside the vehicle could cause fuel to vaporize resulting in a possible explosion.
4. Drain the generator of fuel and oil before being transported on rough roads.

## Storage

Before storing the generator set for an extended period:

- Ensure that the storage area is free of excess humidity and dust.
- Drain the fuel tank and the carburetor.
- To prevent corrosion, coat screws and exposed metal with anti-rust oil at least twice per year.

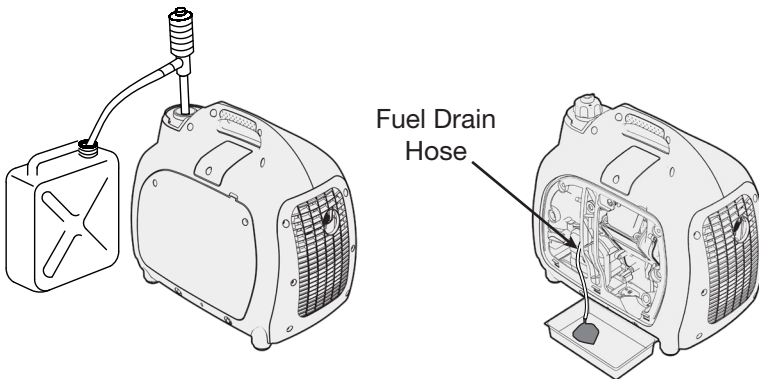

1. Drain off the gasoline from the fuel tank, and store in a suitable container.
2. Rotate the fuel cap vent to ON, turn the fuel switch to OPEN, and loosen the carburetor drain bolt to discharge all gasoline from inside of the carburetor.
3. Take off the spark plug cap, revolve the engine three or four times by pulling on the recoil start, discharge the gasoline from the fuel lines.
4. Turn the fuel switch to CLOSED, rotate the fuel cap vent to OFF, and tighten the drain bolt of carburetor.
5. Reinstall the spark plug cap.

6. Change new oil while engine is still warm from operation.
7. Remove the spark plug, and pour a tablespoon of clean engine oil (10~20ml) into the cylinder. Revolve the engine several times by pulling on the recoil start to distribute the oil. Reinstall the spark plug.
8. Pull the starter grip slowly until you feel resistance. At this point, the piston is coming up on its compression stroke and both the intake and exhaust valves are closed. This position helps to protect the engine from internal corrosion.

## Draining the Fuel Tank

1. Turn OFF the engine. Remove the fuel cap and the debris screen underneath the fuel cap.
2. Empty the fuel tank using a siphon and an approved gasoline container.
3. Rotate the fuel cap vent to ON, turn the fuel switch to OPEN, and loosen the carburetor drain bolt to discharge all gasoline from inside of the carburetor.

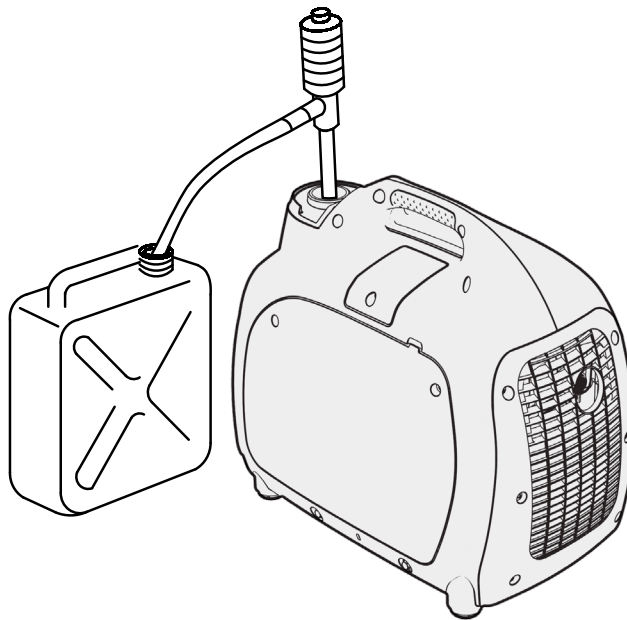

# 9. TROUBLESHOOTING

If the engine does not start:

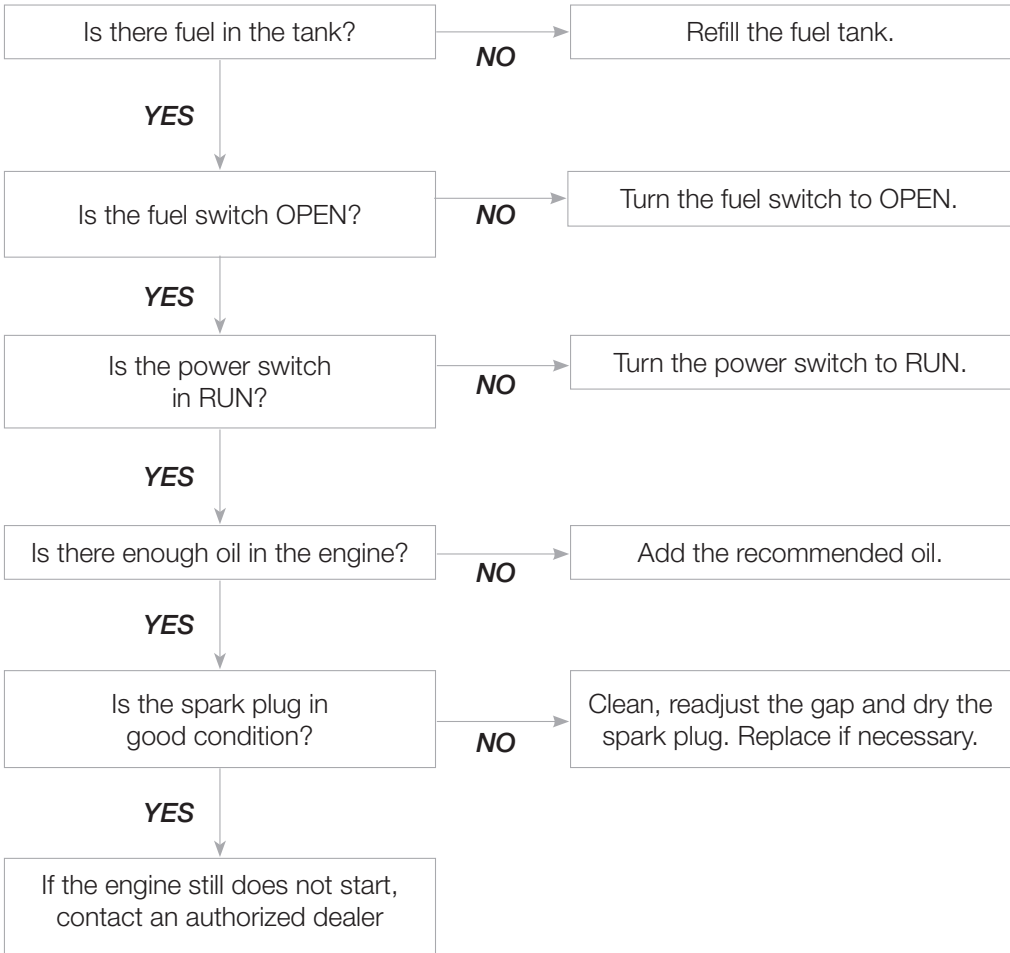

If appliances do not operate:

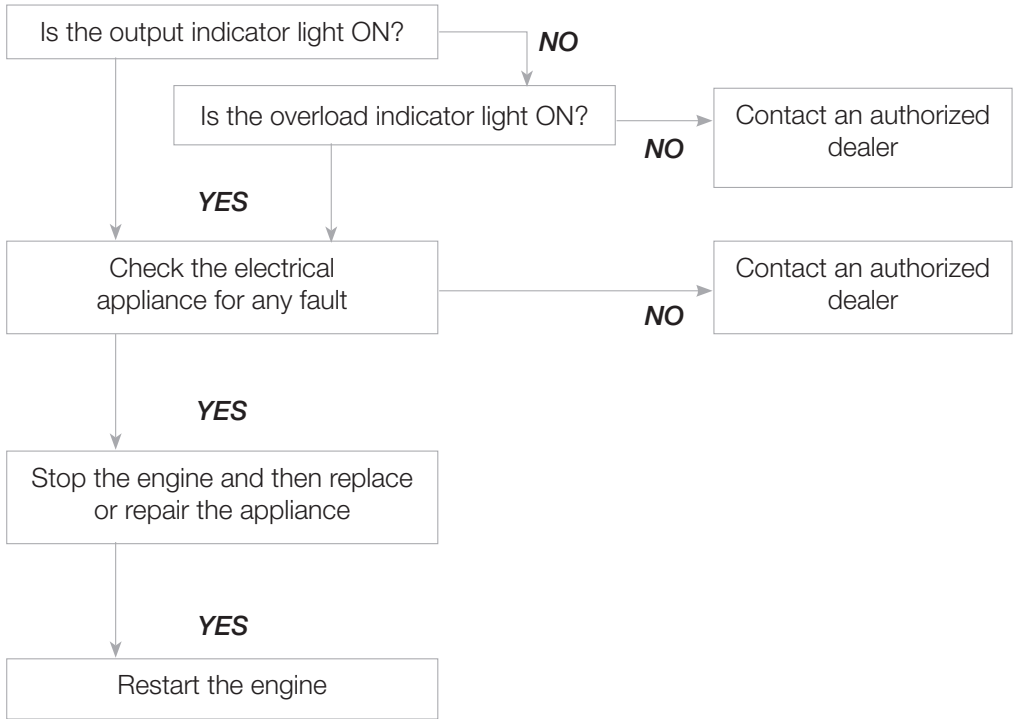

DC receptacle without any electricity:

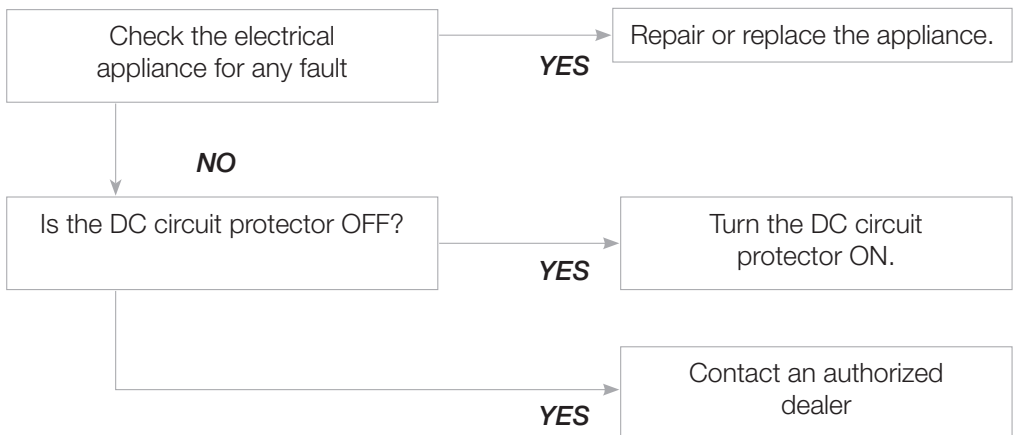

# 10. TECHNICAL SPECIFICATIONS

	SPECIFICATIONS	PARAMETERS
ENGINE	Model Name	DJ148F
	Type	4-stroke, overhead valve, single cylinder, forced-air cooling
	Engine Displacement	79 cc (4.82 cu-in)
	Bore* Stroke	48.6mm x 43.0mm (1.91x 1.69 in.)
	Engine Speed	3200-4500 rpm
	Compression Ratio	7.6:1
	Ignition System	Full transistor
	Start System	Recoil starter
	Fuel Type	Unleaded Gasoline
	Oil Capacity	0.35L (0.09 gal)
	Oil Model	SAE 10W-30
GENERATOR	Model Name	eZV2000P
	Rated Frequency	60Hz
	Rated Voltage	120V
	Rated Current	13.3A
	Rated Output Power	1600W
	Max. Output Power	2000W
OTHER SPECIFICATIONS	DC Output	12V/5A
	Fuel Tank Volume	3.4L / 0.9 gal
	Continuous Running Time	4.2h @ 1600W
	Working Ambient Temperature	-20°C ~ 40°C
	Max. Altitude	1000m (328 ft)
	Sound Power Level at 7m	50-59dB(A)
	Dimensions (L*W*H)	510mm*285mm*450mm
	Net Weight	20kg (44 lbs)

- Noise level is measured when EcoMode is ON and may vary in different environments.

# 11. WIRING DIAGRAM

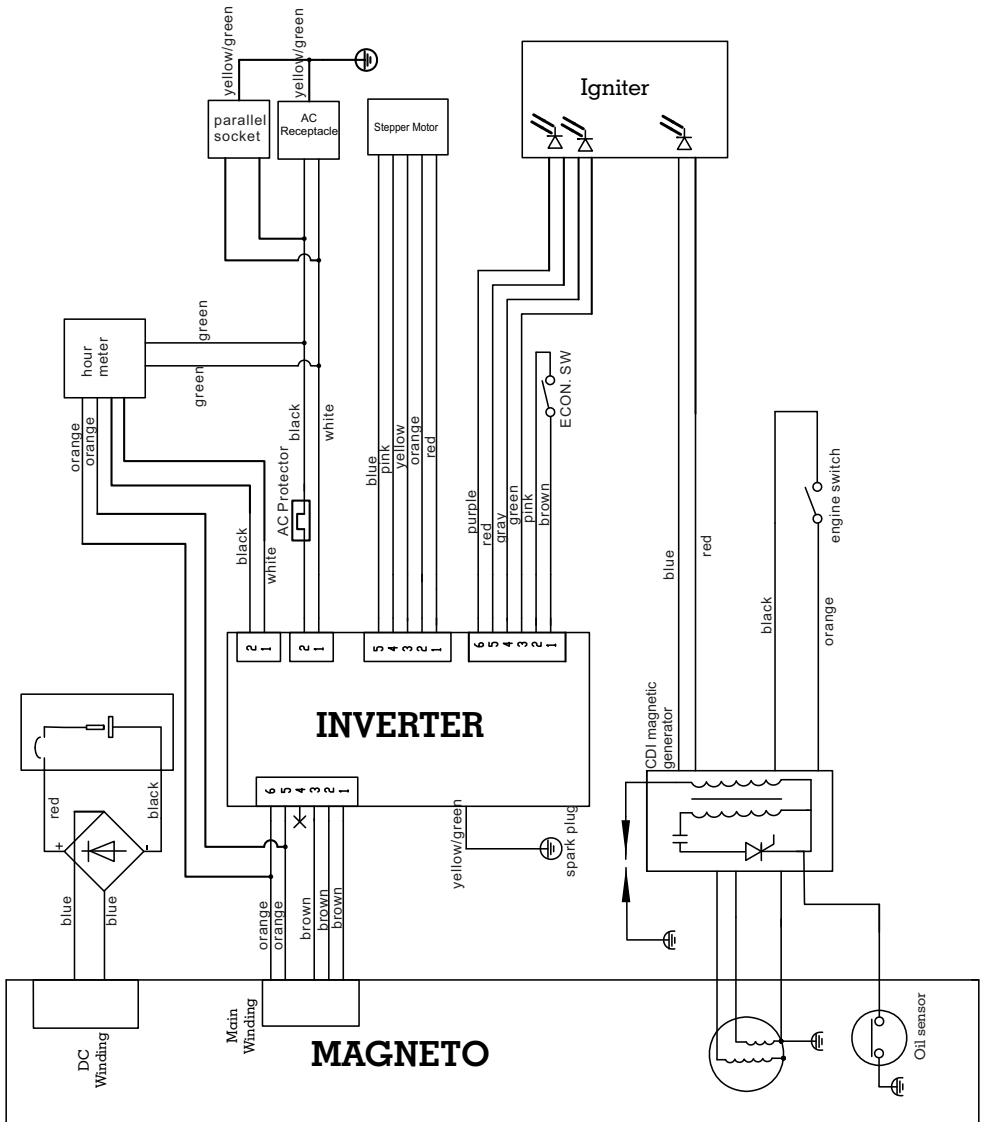

# 12. APPENDIX

The standard condition of rated power output:

Altitude: 0m

Ambient temperature: 25°C

Relative humidity: 30%

## Factor of Environment Correction:

Altitude (m)	Ambient Temperature°C				
	25	30	35	40	45
0	1	0.98	0.96	0.93	0.90
500	0.93	0.91	0.89	0.87	0.84
1000	0.87	0.85	0.82	0.80	0.78
2000	0.75	0.73	0.71	0.69	0.66
3000	0.64	0.62	0.60	0.58	0.56
4000	0.54	0.52	0.50	0.48	0.46

### NOTE:

Relative humidity 60% correction factor C-0.01

Relative humidity 80% correction factor C -0.02

Relative humidity 90% correction factor C-0.03

Relative humidity 100% correction factor C-0.04

### Example:

Rated power ( PN ) 2.8kVA generator (Altitude: 1000m) Ambient temperature: 35°C,

Relative humidity: 80%

$$P=Pn*(C-0.02)=2.8*(0.82-0.02)=2.24kVA$$



## 13. LIMITED WARRANTY

Toll Free: 1-877-528-3772

E-mail: support@energizergenerators.com

Online: www.energizergenerators.com

### ***Energizer***® Generator products are distributed by:

Midland Power Inc.

376 Magnetic Drive, Toronto, ON M3J 2C4, Canada

This product is warranted to be free of defects in material and workmanship for three years from date of purchase. This warranty guarantees that any defective parts will be repaired or replaced at no cost, including diagnosis and replacement parts.

### **Limited Warranty Periods**

Recreational and Residential use: Three Years Limited

- 1st Year: Parts and Labor
- 2nd and 3rd Year: Parts only

Commercial use: Six months limited, parts and labor

This limited warranty begins at the initial time of retail purchase and covers manufacturer's defects caused by a defect in components or workmanship during the three (3) year period. The warranty coverage is continual from the initial date of purchase and does not restart at anytime under any circumstances. This limited warranty is valid for residential or recreational applications only and only when the generator receives all necessary preventative maintenance as described in the User Guide.

The repair or replacement of a generator will take place within a reasonable period of time during normal business hours. All repair and replacement parts shall be warranted for (90) days after the initial date of installation or purchase.

### **Limitation of Remedies and Disclaimers**

Midland International Inc. disclaims any responsibility for loss of time or use of the generator in a recreational vehicle or any vehicle in which the generator is installed, transportation, commercial loss, or any other incidental or consequential damage. Any implied warranties are limited to the duration of this written warranty.

**THE FOREGOING LIMITED WARRANTY IS EXCLUSIVE OF AND IN LIEU OF ALL OTHER WARRANTIES OF MERCHANTABILITY, FITNESS FOR A PARTICULAR PURPOSE AND OF ANY OTHER WARRANTY WHETHER EXPRESS OR IMPLIED.**

Consumable parts, such as oil or fuel filters, fuel cut off valve, brushes, fuel injection nozzle valve, lubricant, or ignition plug, are not covered under this warranty. All expenses incurred in maintaining and replacing parts for generator shall fall on the purchaser. This warranty coverage does not include parts affected by accident and/or collision, corrosion or rust, normal wear, incorrect fuel type or fuel contamination, use in an application for which the product was not intended, unauthorized service, or any other misuse, neglect, incorporation or use of unsuitable attachments or parts. Damage to voltage regulators caused by failure to ground, shorting or overloading will not be covered under this warranty. Under this Warranty, we do not have the obligation to bear any transportation fees of any product to/from an authorized Warranty Center. Unauthorized alteration, installation or any cause other than defects in material or workmanship of the product will not be covered under the warranty.

**Exclusions Not Covered by this Limited Warranty**

- Normal engine/alternator wear.
- Damage caused by lack of maintenance as described in the *Energizer*® User Guides, or negligence by using improper or impure motor oil, coolant, or fuel.
- Damage caused by accidents, improper installation or storage.
- Damage caused by water ingestion, submersion, or external water damage.
- Damage or non-performance caused by operation of the generator set in a marine application.
- Damage caused by operation with improper fuel, or at speeds, loads, conditions, or modifications contrary to published specifications.
- Items not supplied by Midland Power Inc., including, but not limited to, starting batteries, battery cables, external wiring, fuel lines, filters, etc;(refer to exclusions).
- Repairs made during the warranty period, without first obtaining a case number from Midland Power Inc.

## **Batteries**

Batteries supplied with any generator product should be considered a bonus item and not covered by warranty. Batteries can be damaged by shock, shorting terminals, heat, acid spillage and a number of other factors that cannot be controlled after they have left our facility. It is the customer's responsibility to take great care when handling a battery so no spillage of acid will occur and cause corrosion; damage caused by battery acid is not covered under this warranty.

## **Our Warranty Rights and Obligations**

### **California**

The California Air Resources Board and Midland Power Inc. are pleased to explain the emission control system warranty on your Midland Power Inc. engine. In California, new spark-ignited small off-road equipment engines must be designed, built, and equipped to meet the State's stringent anti-smog standards.

### **Other States, U.S. territories, and Canada**

In other areas of the United States and in Canada, your engine must be designed, built, and equipped to meet the U.S. EPA and Environment Canada emission standards for spark-ignited engines at or below 19 kilowatts.

### **All of the United States and Canada**

Midland Power Inc. must warrant the emission control system on your power equipment engine for the period of time listed below, provided there has been no abuse, neglect, or improper maintenance of your power equipment engine. Where a warrantable condition exists, Midland Power Inc. will repair your power equipment engine at no cost to you including diagnosis, parts, and labor.

Your emission control system may include such parts as the carburetor or fuel injection system, the ignition system, and catalytic converter. Also included may be hoses, connectors, and other emission-related assemblies.

## Emission Control System Warranty Parts:

This list applies to parts supplied by Midland Power Inc. and does not cover parts supplied by the equipment manufacturer. Please see the original equipment manufacturer's emissions warranty for non-Midland Power Inc. parts.

Consumable parts are covered up to a maximum of 30 days.

<b>SYSTEMS COVERED IN WARRANTY</b>	<b>PARTS DESCRIPTION</b>
Fuel Metering	Carburetor assembly (includes starting enrichment system), Engine temperature sensor, Engine control module, Fuel regulator, Intake manifold
Evaporative	Fuel Tank, Fuel Cap, Fuel Hoses, Vapor Hoses, Carbon Canister, Canister Mounting Brackets, Fuel Strainer, Fuel cock, Fuel Pump, Fuel Hose Joint, Canister Purge Hose Joint
Exhaust	Catalyst, Exhaust Manifold
Air Induction	Air filter housing, Air filter element
Ignition	Flywheel magneto, Ignition pulse generator, Crankshaft position sensor, Power coil, Ignition coil assembly, Ignition control module, Spark plug cap, Spark plug
Crankcase Emission Control	Crankcase breather tube, Oil filler cap
Miscellaneous Parts	Tubing, fittings, seals, gaskets, and clamps associated with these listed systems

## **Warranty Claim Procedure**

Warranty service must be performed by one of our authorized service dealers. Do not return your product where purchased. If you feel your generator is malfunctioning due to a defect or misuse, simply contact our customer support center for technical advice, a warranty claim or general information. Warranty service, operation assistance and product support is provided by Midland Power Inc., contact us at the numbers below.

## **Product Registration Instructions**

Product registration is required for product support and warranty coverage. You can register online at [www.energizergenerators.com](http://www.energizergenerators.com). Once your registration is complete, your receipt will be on file and any future warranty claims can be easily created. If you wish, you can confirm your registration by calling customer service at 1-877-528-3772 or by e-mailing [support@energizergenerators.com](mailto:support@energizergenerators.com)

Proof of purchase may be required for warranty claims. Keep a copy of the original receipt, UPC code and serial number with this user guide.

## **Customer Service**

Toll Free: 1-877-528-3772

E-mail: [support@energizergenerators.com](mailto:support@energizergenerators.com)

Online: [www.energizergenerators.com](http://www.energizergenerators.com)

**YOU CAN REGISTER EASILY USING OUR ONLINE FORM**  
**[www.energizergenerators.com/eng/register-your-warranty](http://www.energizergenerators.com/eng/register-your-warranty)**

**Enjoy!**

Be sure to check [energizergenerators.com](http://energizergenerators.com) for updates regarding your generator.



***Energizer.*** **eZV**series