

EVERBILT

TM

1.25 in. and 1.5 in. ABS In-Line Sump Pump Check Valve



The Everbilt 1.25 in. and 1.5 in. ABS In-Line Sump Pump Check Valve features 1-1/4" or 1-1/2" combination adapters and the industry's most durable check valve flapper.

It will fit either 1-1/4" or 1-1/2" pipe.

This is one of the world's most reliable sump pump check valves.

Specifications

- **Valve Body:** Acrylonitrile butadiene styrene (ABS) thermoplastic
- **Adapters:** Flexible Polyvinyl chloride (PVC) thermoplastic
- **Clamps:** 301 Stainless Steel
- **Fasteners:** 301 Stainless Steel

Store SKU #1001091718

Features and Benefits

- 1-1/4" or 1-1/2" combination adapters
- Industry's most durable flapper
- All stainless steel clamps
- All stainless steel fasteners
- Strong, durable ABS body
- Fits 1-1/4" or 1-1/2" black, galvanized and DWV Schedule 40 pipe
- Millions in service

Dimensions

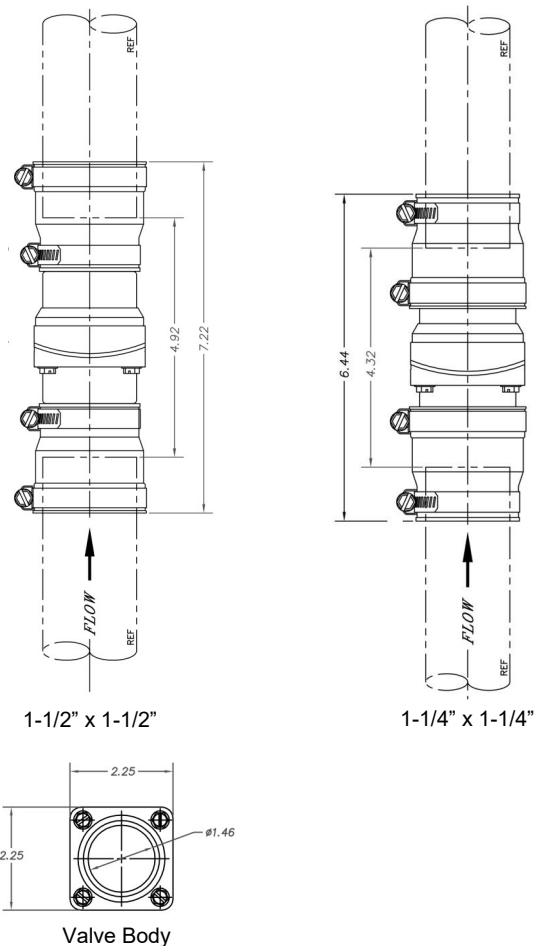

Please contact 1-877-297-6069 for further assistance • HOMEDEPOT.com

© 2018 Jackel, Inc.
EverbiltTHD1020, 06/18