

Pre-Operation

SPECIFICATIONS

Free Speed (RPM)	Square Drive (in.)	Impacts Per Minute	Max. Torque (ft-lb) @ 90 PSI	Weight (lbs)	Length (in)	Air Cons. (SCFM)	Maximum Operating Pressure (PSI)
7,500	1/2	1,050	650	4.80	7.66	5.0	90

PACKAGE CONTENTS

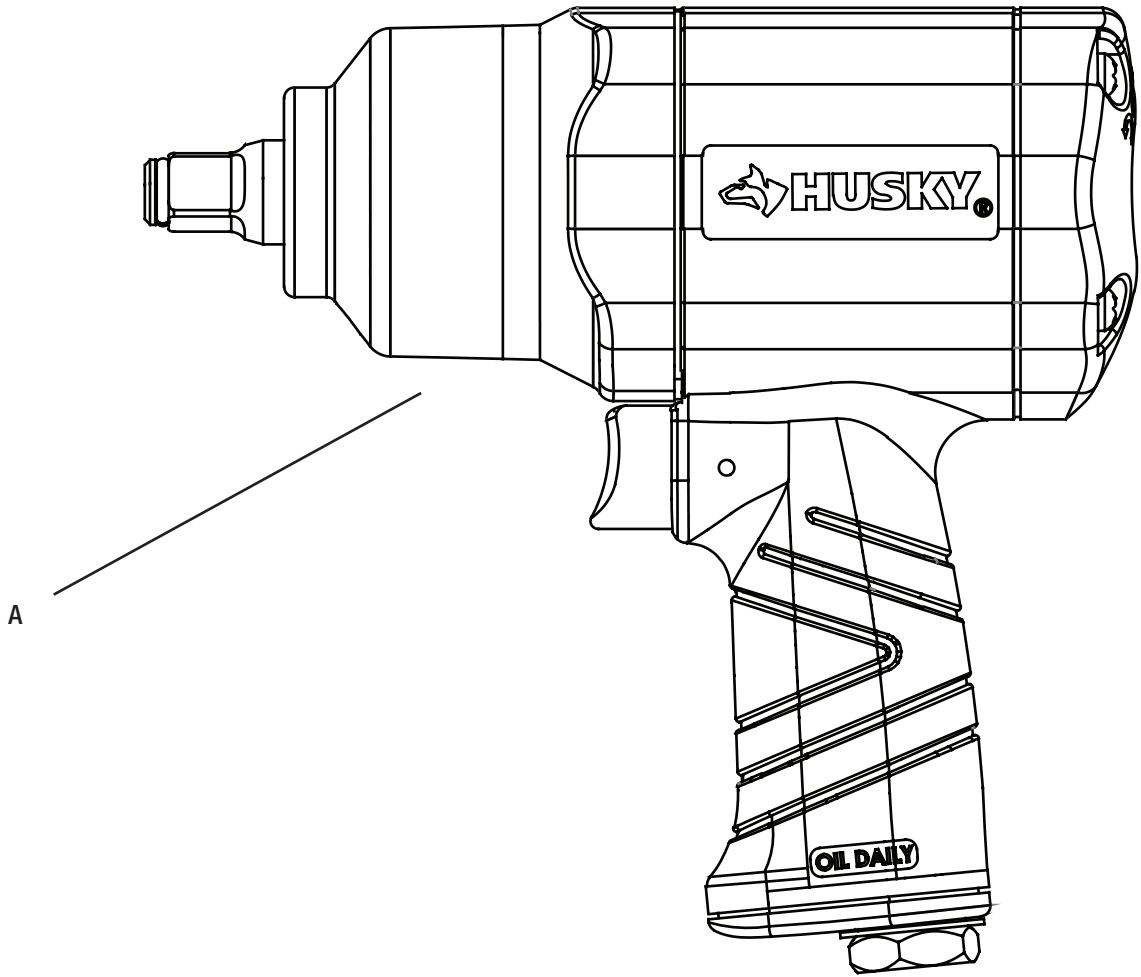

Part	Description	Quantity
A	1/2-in. Impact Wrench	1