

LIMITED WARRANTY* ONE (1) YEAR:

Your small kitchen appliance is warranted to the original purchaser to be free from any manufacturing defects under normal use and conditions for one (1) year, cord excluded. During that period, should the appliance fail to operate properly, return the appliance with your sales receipt to the store where purchased. If you use your appliance for household use and according to instructions, it should give you years of satisfactory service. This product warranty covers only the original consumer purchaser of the product.

WARRANTY IS ONLY VALID WITH A DATED PROOF OF PURCHASE.

To guarantee repair or replacement without charge, a dated sales receipt showing purchase within the limited warranty period* must accompany the appliance. Without a sales receipt, warranty will be estimated according to the appliance's manufactured date. A comparable appliance should arrive within 2-3 weeks. However, in case an appliance is not covered by warranty, correspondence offering alternatives will be mailed to you.

During the one-year warranty period, a product with a defect will be either repaired or replaced with a reconditioned comparable model (at our option) when the product is returned to our Service Center. (See the "Returns" section below). The repaired or replacement product will be in warranty for the remaining balance of the one-year warranty period and an additional one-month period.

This limited warranty covers appliances purchased and used within the 50 contiguous states plus the District of Columbia and does NOT cover:

- Damages caused by unreasonable use, neglect, normal wear and tear, commercial use, improper assembly or installation of product.
 - Damages caused in shipping.
 - Damages caused by replacement or resetting of house fuses or circuit breakers.
 - Defects other than manufacturing defects.
 - Breakage caused by misuse, abuse, accident, alteration, lack of proper care and maintenance, or incorrect current or voltage.
 - Lost or missing parts of the product. Parts will need to be purchased separately.
 - Damages of parts that are not electrical; for example: cracked or broken plastic or glass.
 - Damage from service or repair by unauthorized personnel.
 - Extended warranties purchased via a separate company or reseller.
 - Consumer's remorse is not an acceptable reason to return a product to our Service Center.
- *The consumer is responsible for any delivery charges for all replacement units provided for exchange under the warranty.

RETURNS: Any return of defective merchandise to the manufacturer must be processed accordingly by contacting customer service first to obtain an RA # (Return Authorization Number). We will not accept any returns of merchandise without an applicable RA #.

We cannot assume responsibility for loss or damages to products returned to us during incoming shipment. For your protection, always carefully package the product for shipment and insure it with the carrier. Be sure to enclose the following items with your return: any accessories related to the problem, your full address and daytime phone number, a note describing the problem, a copy of the dated sales receipt or other proof of purchase and a valid RA#.

C.O.D shipments cannot be accepted.

*One Year Limited Warranty valid only in the **50 contiguous states plus the District of Columbia, excluding** Puerto Rico and the Virgin Islands.

This warranty is effective only if the product is purchased and operated in the USA; product usage which is in violation of the written instructions provided with the unit will void this warranty. For international warranty, please contact the local distributor.

**Any instruction or policy included in this manual may be subject to change at any time.

Model EDF-4080

Elite Platinum Dual Basket Deep Fryer

Distributed by: **MAXI-MATIC®**, USA

18401 E. Arenth Ave. City of Industry, CA 91748

Customer Service Department: (626) 912-9877 Ext. 120 MON-FRI 10am-5pm PST

Email: info@maxi-matic.com Or visit our website: www.maxi-matic.com

Elite
BY MAXI-MATIC®
PLATINUM

Dual Basket Deep Fryer (4Qt. Capacity each)



Model EDF-4080

INSTRUCTION MANUAL

Before operating your new appliance, please read all instructions carefully and keep for future reference. MAXI-MATIC is continuously improving our product development. This may result in slight variances between the photography of the product compared to the actual contents inside the box.

IMPORTANT SAFEGUARDS

When using electrical appliances, basic safety precautions should always be followed, including the following:

1. Read all instructions before operating.
2. Do not touch hot surfaces. Use handles or knobs if applicable.
3. Remove all packaging plastics and other materials from unit before operating.
4. Wash all removable accessories before using for the first time.
5. To protect against electrical shock, do not immerse cord, plug or appliance itself in water or other liquids.
6. Close supervision is necessary when appliance is used by or near children.
7. Unplug from outlet when not in use and before cleaning. Allow to cool before putting on or taking off parts.
8. Do not operate any appliance with a damaged cord or plug or after the appliance malfunctions or has been damaged in any manner. Return the appliance to the nearest authorized service facility for examination, repair or adjustment.
9. The use of accessory attachments not recommended by the appliance manufacturer may cause injuries.
10. Do not use outdoors.
11. Do not let cord hang over edge of table or counter or touch hot surfaces.
12. Do not place on or near a hot gas or electric burner, or in a heated oven.
13. Always attach plug to appliance first, then plug cord into wall outlet. To disconnect, turn any control to OFF position, then remove plug from wall outlet.
14. Oversized foods or metal utensils must not be inserted in the appliance as they may cause a fire or risk of electrical shock.
15. A fire may occur if the appliance is covered or touching flammable material including curtains, draperies, walls and the like when in operation.
16. Do not clean with metal scouring pads. Pieces can break off the pad and touch electrical parts, involving a risk of electrical shock.
17. Extreme caution should be exercised when using containers constructed of other material other than metal or glass.
18. Do not store any materials other than manufacturer's recommended accessories in this unit when not in use.
19. Do not place any of the following materials in the unit: Paper, cardboard, plastic and / or similar non-food materials.
20. Some countertop and table surfaces, such as Corian®, wood and / or laminates, are not designed to withstand prolonged heat generated by certain appliances. It is recommended by countertop manufacturers and Maxi-Matic that a hot pad or trivet be placed under your Elite deep fryer to prevent possible damage to the surface.

SAVE THESE INSTRUCTIONS

THIS PRODUCT IS FOR
HOUSEHOLD USE ONLY!

1

KNOW YOUR DEEP FRYER

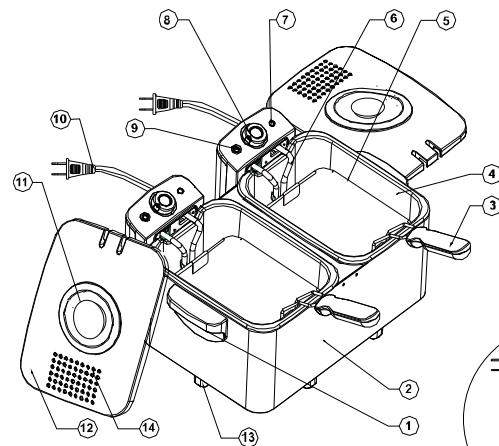

- 1) Carrying Handle
- 2) Fryer Main Body
- 3) Basket Handle
- 4) Oil Container
- 5) Frying Basket
- 6) Heating Element
- 7) Green Indicator Light
- 8) Temperature Control Knob
- 9) Red Indicator Light
- 10) Power Cord
- 11) Knob on Lid
- 12) Fryer Lid
- 13) Peg Stand Feet
- 14) Ventilation Holes
- 15) Safety Heating Switch

****It is recommended to plug the appliance into two separate power outlets when using both units simultaneously.**

***15) SAFETY HEAT SWITCH:** This switch is to ensure that the heating element will not power on when it is not safely in place. The control box and heating elements must always be slid into place securely before operation or heating of the fryer will start.

2

RECOMMENDATIONS

1. Always place the deep fryer on a stable surface and keep all flammable materials away from the unit during operation.
2. Make sure that the deep fryer is never near or on a switched-on stove or cooking surface.
3. Before you use the deep fryer it must be filled with the required amount of oil or fat. ****Never use the deep fryer without oil or fat because this could damage the unit.**
4. **Never move the deep fryer during use.** The oil becomes very hot. Wait until the unit and the oil has completely cooled down before moving.
5. This deep fryer is protected with a thermal safety device which switches the machine off automatically if it over heats.
6. **It is recommended to plug the appliance into two separate power outlets when using both units simultaneously.**
7. Never immerse the appliance in water.
8. Never leave the deep fryer unattended while in use.
9. Always ensure the safety of children if they are near the deep fryer.
10. If the deep fryer and/or cord are damaged, they must be repaired by a professional service department. Do not try to repair the unit yourself or replace the damaged cord. This requires special tools.
11. Be sure not to damage the heating element. (Do not bend or dent)
12. The electrical component is required with a safety heat switch, which ensures that the heating element can only function when the element is correctly placed on the fryer.
13. In the case of overheating, the thermal protective device will switch off the fryer automatically. This device is a small red button found either on the underside of the electrical component, or in the cord storage compartment. It can be re-activated by pushing the button in again with a pointed object (e.g. a pen).
****Disconnect from power outlet before re-activating!**

PREPARING YOUR FRYER

BEFORE USING FOR THE FIRST TIME:

- Remove all printed documents and any other packaging materials.
 - Pull out all removable parts and wash gently with hot water.
- Do not immerse the power cord and Control Box Assembly & Heating Element of the deep fryer into any liquids.**
- Dry all parts thoroughly before assembling.
 - Do not operate the fryer without enough oil in the oil tank.
 - The Deep Fryer should always be placed on a flat and stable surface where the power cord is out of reach from children and away from accidental entanglement.

Tips:

- When you fry several different kinds of food, always fry the food that uses the lowest temperature setting first.
- Do not mix different types of oil for frying.
- Frying already pre-cooked foods may take less time to fry than completely raw food.
- Replace the oil after each 10-15 uses; or earlier if the oil becomes brown and thick.

SAFETY TIPS

- **THIS DEEP FRYER IS ONLY SUITABLE FOR USE WITH OIL OR LIQUID FAT AND NOT FOR USE WITH SOLID FAT. IF SOLID FAT IS USED, WATER CAN BECOME TRAPPED INSIDE AND THE HOT FAT MAY SPURT OUT WITH CONSIDERABLE FORCE.**
- Never switch on the deep fryer without oil or liquid fat, as this could damage the machine. Also, do not place any other liquids such as water or other substances in the pan.
- Place the deep fryer on a dry, stable surface. Since the deep fryer becomes hot during use, make sure that it is not too close to other objects.

OPERATING INSTRUCTIONS

- Make sure the Deep Fryer is UNPLUGGED.
 - Remove the frying basket and make sure the handle is swung out and locked.
 - Use only good quality frying oil such as Peanut oil, Vegetable oil, pure Corn oil, Sunflower oil, Canola oil, or Light Olive oil. (Recommended not to mix oil)
 - Fill oil into the oil container approximately between the MIN marking and the MAX marking.
 - **Do not fill over the MAX marking or lower than the MIN marking.**
 - Make sure the temperature control knob is set to the OFF or 0 position.
 - Connect the PLUG to the back of the control box properly. Make sure the connection is right-side-up and the connection is properly secure.
 - PLUG the power cord into an outlet.
 - Move the Thermostat knob to desired temperature setting according to the particular recipe you are using. The RED & GREEN indicator light will turn on.
 - While the oil is preheating, prepare the food that is going to be fried.
 - When placing the food into the basket, make sure it is as dry as possible. Do not add water, ice or wet food, it may cause HOT OIL SPLATTER.
 - When frying Frozen food, clear off any ice particles and thaw food thoroughly.
 - Do not overfill the basket.
 - When the temperature has been reached, the RED indicator light will shut OFF, the fryer is ready to fry food.
 - Lower basket of food into hot oil and cover fryer w/ lid.
- WARNING: DO NOT TOUCH THE CONTROL KNOB WHEN THE FOOD IS FRYING. HOT STEAM MAY BE ESCAPING AND CAUSE BODILY HARM.**
- Remove food after desired cooking time has elapsed. Take care to remove foods before it starts soaking up too much oil.

RESET BUTTON:

- If your deep fryer's heating elements shut off in the middle of frying and does not come back on, unplug the unit, allow to cool off up to 10-minutes. Re-plug the power cord and power back on.
- If the deep fryer still does not power on or heat up, please locate the Reset Button on the control box. It is located on the back of the control box next to the power cord socket.
- The Reset Button is located inside a small hole. Unplug the deep fryer from any power outlet. Use a small thin tool to stick into the small hole to push in on the Reset Button.
- Re-plug the power cord and power back on.

FRYING GUIDE

The frying times given in the chart are only a guide and should be adjusted accordingly to the quantity of food being fried.

FOOD	Temp. °F	Weight (grams)	Estimated Time
Shrimp	285°	250	3-5 minutes
Onion	285°	150	3-4 minutes
Mushrooms	285°	300	6-8 minutes
Fish Fillet	300°	250	5-6 minutes
Fish Fillet in batter	300°	400	6-8 minutes
Fish Cakes or Balls	300°	400	6-8 minutes
Sliced Meat	340°	400	7-10 minutes
Steak	340°	400	7-10 minutes
Chicken Strips	360°	500	7-10 minutes
French Fries (1 st time)	375°	500	6-10 minutes
French Fries (2 nd time)	375°	250	3-5 minutes

*French Fries being fried a 2nd time will be lighter and crispier.

AFTER THE FOOD IS FRIED:

1. Make sure to turn the temperature control knob to the OFF position and unplug the deep fryer.
2. Once food is done cooking, remove the lid, and hang the basket on the hook and let excessive oil drip into the oil pot.
Warning: Removing the lid will release hot steam. Take extreme care when handling. Keep face and bare skin clear of the steam release.
3. Take out the basket and place the food on paper towels to absorb excess oil.
Do not touch the basket while it is still hot. Always use the handle.
4. Transfer food to a clean dish without the paper towels.
5. Place the basket into the deep fryer.
6. Do not move the deep fryer until it is cooled entirely.
7. Unplug the power cord and store away.

PLASTIC LID:

- When your deep fryer reaches high temperatures and the plastic lid is left on your deep fryer for prolonged period of time, this may result in slight warping of the shape of the lid.
- Once the temperature has cooled down, the lid should reshape itself back to its original form.
- It is recommended to not leave the plastic lid on the deep fryer during operation for no longer than 10-minutes at a time.

CLEANING THE DEEP FRYER

1. Remove the lid and basket.
WARNING: Before cleaning the deep fryer, make sure that it is disconnected from the power outlet, make sure the unit and the oil has completely cooled. Oil retains its temperature for a long period after use. Do not attempt to carry or move the deep fryer while the oil is hot.
2. Wait for the fryer to cool, lift out the Control Box Assembly & Heating element.
3. Remove the oil pot and pour out the oil. It is recommended to filter the oil after each use if you are to re-use the oil again.
4. After removing the oil pot, the fryer can be divided into several separate assemblies to clean.
5. The oil pot and the body can immerse into water to clean.
6. The Control Box & Heating Element should be wiped clean with absorbent power towels. Then use a damp cloth and a mild soap to clean.
WARNING: Do not immerse the Control Box & Heating Element into water to clean.
7. Dry thoroughly all parts.
Note: Do not use abrasive scrubbing brushes or chemical cleaners to clean the unit.

CARING FOR YOUR DEEP FRYER

STORING YOUR DEEP FRYER:

Always allow the appliance to cool completely before storing. Store the appliance in a dry location. Keep the power cord out of reach of children.

SHORT CORD PURPOSE

- 1) A short power-supply cord is provided to reduce risks of injuring yourself from becoming entangled in or tripping over a longer cord.
 - 2) Longer extension cords are available and may be used if you exercise caution during use.
 - 3) If a longer cord is used please note the following:
 - The marked electrical rating of the extension cord should be at least as great as the electrical rating of the appliance.
- The longer cord should be arranged so that it will not drape over the counter top of tabletop where it can be pulled on by children or tripped over unintentionally.

POLARIZED PLUG

If this appliance has a **polarized plug** (meaning one blade is wider than the other one), please follow the below instructions:

To reduce the risk of electric shock, this plug is intended to fit into a polarized outlet only in one direction. If the plug does not fit fully into the outlet, reverse the plug. If it still does not fit, contact a qualified electrician. Do not attempt to modify the plug in any way.

This appliance is intended for Household Use Only.

IT IS RECOMMENDED TO PLUG THE APPLIANCE INTO TWO SEPARATE POWER OUTLETS WHEN USING BOTH UNITS SIMULTANEOUSLY.

RECIPES

BATTER VARIETY:

The following are a few quick recipes for different kinds of batter to use with a variety of foods to fry up in the deep fryer for a delicious meal.

Beer Batter:

Mix together 1 ½ cups of flour and 1 ½ cups of any kind of beer in a large mixing bowl. Cover the bowl after mixing and allow the batter to sit at room temperature for approximately 3 hours. When ready to fry, dip desired food into the batter and follow the directions for frying battered foods in this booklet.

Egg Batter:

Combine 2 egg yolks, ¾ cup of flour, 1-½ teaspoons of vegetable oil, ½ teaspoon of salt and 1 cup of milk. Mix thoroughly. Add more milk if desired to adjust the density of the mixture. When ready to fry, dip desired food into the batter and follow the directions for frying battered foods in this booklet.

Egg Coating:

Combine 2 whole eggs with 1-½ teaspoons of vegetable and a pinch of salt and pepper to taste. When ready to fry, dip desired food into the mixture and follow the directions for frying foods in this booklet.

Extra Crispy Coating:

Beat together ½ cup milk and one whole egg in a small mixing bowl. In a separate bowl, mix together ½ cup of flour and any of your favorite seasonings such as salt, pepper, chili powder, garlic powder, etc. When read to fry, dip desired food into the wet mixture first, then dip into the dry flour mixture. Then follow the directions for frying foods in this booklet.

Bread Crumb Coating:

Beat together 1 ½ teaspoons of vegetable oil and 2 egg yolks in a small mixing bowl. IN a separate bowl, mix together ½ cup of bread crumbs, 1/3 cup of flour plus any of your favorite seasonings such as salt, pepper, chili powder, garlic powder, etc. When read to fry, dip desired food into the wet mixture first, then dip into the dry bread crumb mixture. Then follow the directions for frying foods in this booklet.

TIPS FOR FRYING FOOD WITH BATTER COATING:

- Make sure food is always sliced thinly and evenly. This helps the food to be fried evenly.
- Shake off any excess flour or bread crumb coating to prevent any clumps to form when frying.
- If you wish to use the basket when frying foods coated with batter, it is recommended to lower the basket into the hot oil first and then gently and carefully place battered foods into the oil directly. This will prevent the batter from catching and sticking to the wiring of the basket.
- Never fill the basket more than 2/3 full. In order to cook evenly, the food needs space for the frying oil to fry each side.

BEIGNETS:

Vegetable oil for frying	1/3 c. butter
1 c. all-purpose flour	1/4 tsp. salt
4 tsp. sugar	1 tsp. vanilla extract
1/4 tsp. nutmeg	4 eggs, at room temp.
1 c. water or milk	

- In a large heavy skillet or deep-fat fryer, heat 3 inches oil to 350 degrees.
- Meanwhile, combine flour, sugar and nutmeg, set aside. In medium saucepan heat water or milk, butter and salt over medium heat until boiling and butter is melted. Add vanilla, then add flour mixture all at once.
- Stir briskly with a wooden spoon until mixture leaves sides of pan and forms a ball. Continue stirring a few minutes more to dry.
- Remove from heat and beat until slightly cooled.
- Add eggs, one at a time, beating well after each addition. Using 2 spoons, shape a generous tablespoon dough into an oblong and drop into hot oil.
- Fry 3 or 4 at a time, turning beignets as they rise to the surface. Fry 3 to 4 minutes, until golden brown.
- Drain on paper towels and sprinkle immediately with sifted confectioners' sugar. Repeat with remaining batter.
- Makes about 2 dozen beignets

SHRIMP EGG ROLLS:

1 c. sifted flour	1/4 c. minced water chestnuts
3 eggs	1 tbsp. finely chopped onion
2 c. minced cooked shrimp	1 qt. corn oil
1 c. finely chopped celery	1/2 tsp. salt
1/4 c. minced bamboo shoots	1/4 tsp. Accent

- Combine flour, 1-cup water and 2 eggs. Beat at low speed of electric mixer for 5 minutes. Set aside for at least 15 minutes.
- Mix shrimp, celery, bamboo shoots, water chestnuts, onion, 2 tablespoons corn oil and seasonings thoroughly.
- Heat heavy 6-inch skillet until drop of water will sizzle. Grease lightly with corn oil before cooking each skin. Hold skillet off heat; pour 2 to 3 tablespoons batter into pan, moving and tilting pan while pouring. Pour excess back into bowl of batter; return skillet to heat. Batter will set very quickly.
- Cook just until set and edge curls slightly. Turn out onto dry dishtowel until ready to roll.
- Place about 2 tablespoons filling in center of each skin; brush edge with beaten egg. Fold nearest edge over filling; fold over sides about 1 inch. Roll skin; seal with beaten egg. Pour enough of remaining corn oil into deep fryer or skillet to fill 1/3 full.
- Heat over medium heat to 375 degrees or until 1-inch square of bread turns brown in 10 seconds.
- Add several egg rolls slowly; fry until lightly browned on all sides, turning as needed. Drain on absorbent paper. Repeat with remaining rolls. Yield: 15 egg rolls.

FUNNEL CAKE:

2 c. flour
1 tsp. baking powder
1/2 tsp. salt
2 eggs
1 1/2 c. milk

- Combine all the above ingredients in order. Mix thoroughly.
- Heat cooking oil in deep fryer until hot.
- Put batter in funnel (be sure to cover hole with one finger), then, holding the funnel over hot oil (be very careful!), release some of the batter in circular motion, then criss-crossing motions to form one funnel cake.
- The funnel cake will rise quickly and expand - so be careful how much batter you use.
- Cook to light golden brown on both sides.
- Remove from oil and place on paper towels.
- Sprinkle with powdered sugar and serve warm.

GOLDEN FRIED ONION RINGS:

6 med. mild white onions
1 1/8 c. sifted flour
1/2 tsp. salt
1 egg, slightly beaten
1 c. milk

- Slice onion 1/4 inch thick and separate into rings.
- Combine remaining ingredients in a bowl and stir just until dry ingredients are moistened.
- Dip onion rings into flour mixture.
- Fry several at a time in a deep fryer until golden brown. Drain on paper towel and sprinkle with salt.

BUFFALO WINGS:

24 wings (4 lbs.)
Salt & pepper (optional)
4 c. cooking oil
1/4 c. butter
2 to 5 tsp. hot sauce
1 tsp. white vinegar

- Cut off tips and separate wings at joint; sprinkle with salt and pepper, to taste.
- Heat oil in deep fat fryer or large heavy pot. When quite hot, add 12 wings and cook 10 minutes, stirring occasionally.
- When wings are golden brown and crisp, remove and drain well. Add rest of wings; repeat process.
- Meanwhile, melt butter in saucepan; add hot sauce, to taste and vinegar. Pour sauce over wings and mix well to cover.
- Serve with Blue Cheese Dressing and celery sticks.

CORN DOGS:

1/2 c Yellow corn meal
1/2 c Flour
1 tsp Honey
1/2 tsp Salt
1 ea Egg, lightly beaten
6-8 Hot Dogs / Frankfurters

6 ea Skewers or sticks
1 tbsp Sugar
1 tsp Baking powder
1/2 c Milk
1 tbsp Melted shortening

- Combine the cornmeal, flour, sugar, mustard, baking powder and salt, mixing well.
- Add the milk, egg and shortening, mixing until very smooth.
- Pour the mixture into a tall glass. Put the frankfurters on sticks.
- Dip them into the cornmeal batter to coat them evenly.
- Deep fry in oil heated to 375 degrees until golden brown, about two minutes.
- Drain on paper towels.

FRIED GREEN TOMATOES:

3-4 lg. green tomatoes
2 c. flour
1 tsp. salt
1 tsp. pepper

1 tbsp. seasoning salt
2 eggs
2 c. milk
Oil for frying

- Cut tomatoes into almost 1/2-inch thick slices.
- Mix flour, salt, pepper and seasoning salt in one bowl.
- Mix eggs and milk in another bowl. Dip each tomato slice into the milk mixture, then into the flour, back to the milk and then to the flour again, coating well.
- Heat oil in a deep fryer to 350 degrees and add battered tomato slices a few at a time, and cook for 5 minutes or until golden brown.

CHURROS:

Vegetable for frying
1 cup water
1/2 cup margarine or butter
1/4 teaspoon salt

1 cup all-purpose flour
3 eggs
1/4 cup sugar
1/4 teaspoon ground cinnamon

- Prepare to fry the churros by heating oil in deep fryer to 360 degrees F.
- To make churro dough, heat water, margarine and salt to rolling boil in 3-quart saucepan; stir in flour.
- Stir vigorously over low heat until mixture forms a ball, about 1 minute; remove from heat.
- Beat eggs all at once; continue beating until smooth and then add to saucepan while stirring mixture.
- Spoon mixture into cake decorator's tube with large star tip (like the kind use to decorate cakes).
- Squeeze 4-inch strips of dough into hot oil. Fry 3 or 4 strips at a time until golden brown, turning once, about 2 minutes on each side. Drain on paper towels.
- Mix Sugar and the optional cinnamon; roll churros in sugar mixture.

SWEET & SOUR CHICKEN:

MARINADE:

1/2 tsp. salt
1 1/2 tsp. soy sauce
1 tbsp. cornstarch
1 tbsp. cold water

BATTER:

1/2 c. chicken coating mix
1/2 c. ice water
1 egg yolk

SWEET AND SOUR SAUCE:

1/2 c. Kraft Sweet and Sour Sauce
1/4 c. chicken broth
1/4 c. water
1/2 tsp. cornstarch
1 green pepper, cut into 1 inch pieces
1 med. carrot, sliced inch long then lengthwise
1/2 c. sliced water chestnuts
1 can chunk pineapple

- Combine marinade ingredients in a small bowl. Add chicken, mix well. Let stand 30 minutes.
- Combine batter ingredients in a medium bowl until just mixed. Do not stir to blend.
- Combine Sweet and Sour Sauce, chicken broth, water and cornstarch in a small bowl, set aside.
- Heat oil in deep fryer to 350 degrees
- While oil is heating, coat each piece of chicken with batter. Reduce heat to medium.
- Carefully lower coated chicken into hot oil with fryer basket.
- Deep fry chicken 3 minutes or until browned. Remove from oil.
- Turn heat up to high and heat oil to 400 degrees.
- Carefully place chicken all at once in hot oil and deep-fry until crisp, about 30 seconds.
- Remove chicken, draining well. Place on platter.
- Using a fry pan, place 2 tablespoons oil. Heat to medium. Stir-fry green peppers, carrots and water chestnuts 2 minutes.
- Add Sweet and Sour Sauce mixture. Stir in pineapple. Stir-fry until sauce has thickened. Remove from heat.
- Stir in chicken and serve immediately. Makes 4 servings.