

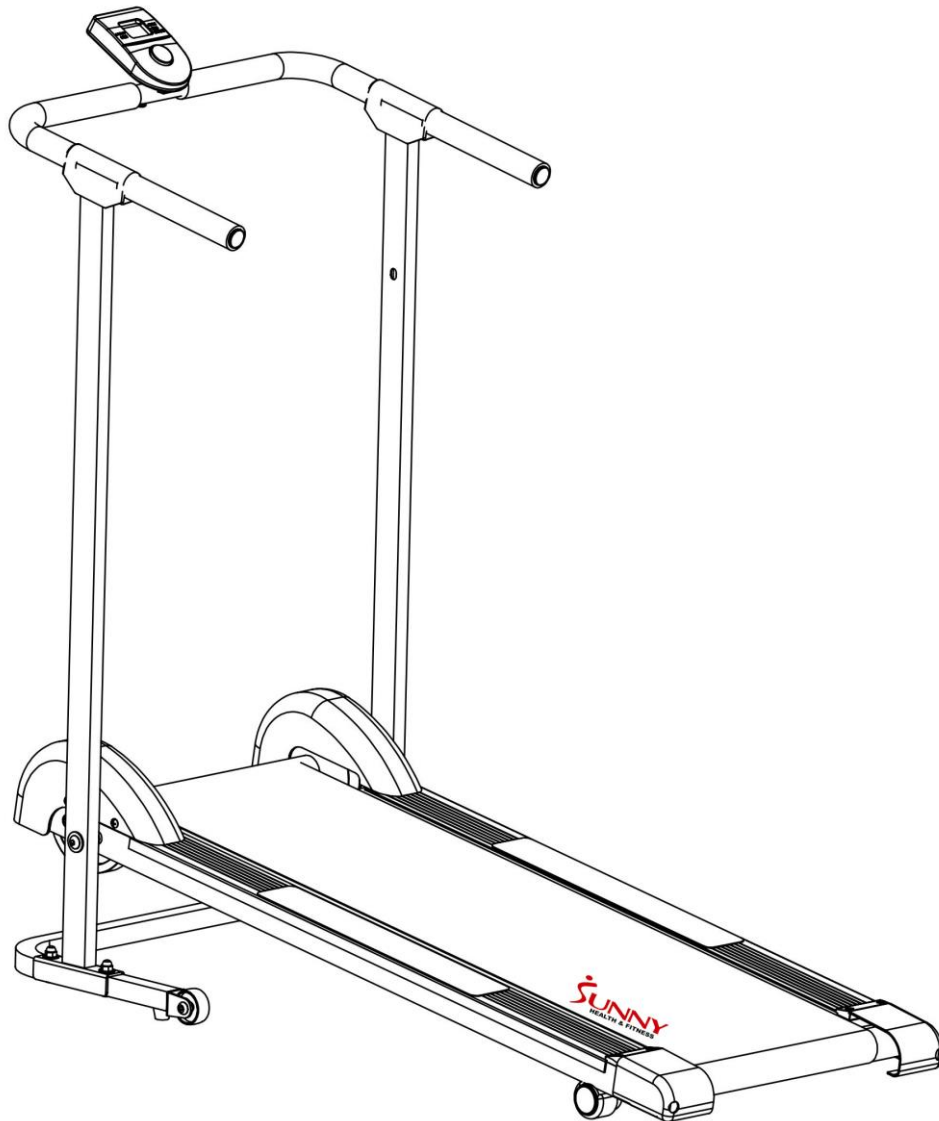

MANUAL WALKING TREADMILL

SF-T1407M

USER MANUAL



IMPORTANT: Please read this manual carefully before using the product. Retain owner's manual for future reference. For Customer Service, please contact: support@sunnyhealthfitness.com

IMPORTANT SAFETY INFORMATION

We thank you for choosing our product. To ensure your safety and health, please use this equipment correctly. It is important to read this entire manual before assembling and using the equipment. It is your responsibility to ensure that all users of the equipment are informed of all warnings and precautions.

1. Before starting any exercise program you should consult your physician to determine if you have any medical or physical conditions that could put your health and safety at risk, or prevent you from using the equipment properly. Your physician's advice is essential if you are taking medication that affects your heart rate, blood pressure or cholesterol level.
2. Be aware of your body's signals. Incorrect or excessive exercise can damage your health. Stop exercising if you experience any of the following symptoms: pain, tightness in your chest, irregular heartbeat, and extreme shortness of breath, lightheadedness, dizziness or feelings of nausea. If you do experience any of these conditions, you should consult your physician before continuing with your exercise program.
3. Install the treadmill on a flat level surface; do not block the rear of the treadmill. Provide a minimum of 2 feet of space around the treadmill. Place your unit on a solid, level surface when in use.
4. Do not operate the treadmill on deeply padded, plush or shag carpet, as damage to both the carpet and treadmill may occur.
5. Never allow children on or near the treadmill. The equipment is designed for adult use only.
6. For your safety handrails should always be held whenever starting or stopping an exercise or whenever increasing or decreasing speeds.
7. Do not place fingers or objects into moving parts of the exercise equipment. Never drop or insert any object into any openings.
8. Always use equipment as indicated. Ensure that all nuts and bolts are securely tightened before using the equipment. The safety of the equipment can only be maintained if it is regularly examined for damage and/or wear and tear. If you find any defective components while examining the equipment, or hear any unusual noises coming from the equipment during exercise, stop using the equipment immediately and discontinue use until the problem has been rectified.
9. Wear suitable clothing and proper shoes while using this equipment. Avoid wearing loose clothing that may become entangled in the equipment.
10. The maximum weight capacity of this unit is 220 lbs.
11. This equipment is not suitable for therapeutic use.
12. Always use proper lifting technique when lifting the equipment and seek assistance if necessary.
13. This equipment is designed for indoor and home use only! It is not intended for commercial use.



WARNING: This product can expose you to one or more chemicals known to the State of California to cause cancer and birth defects or reproductive harm. For more information go to www.P65Warnings.ca.gov.

EXPLODED DRAWING

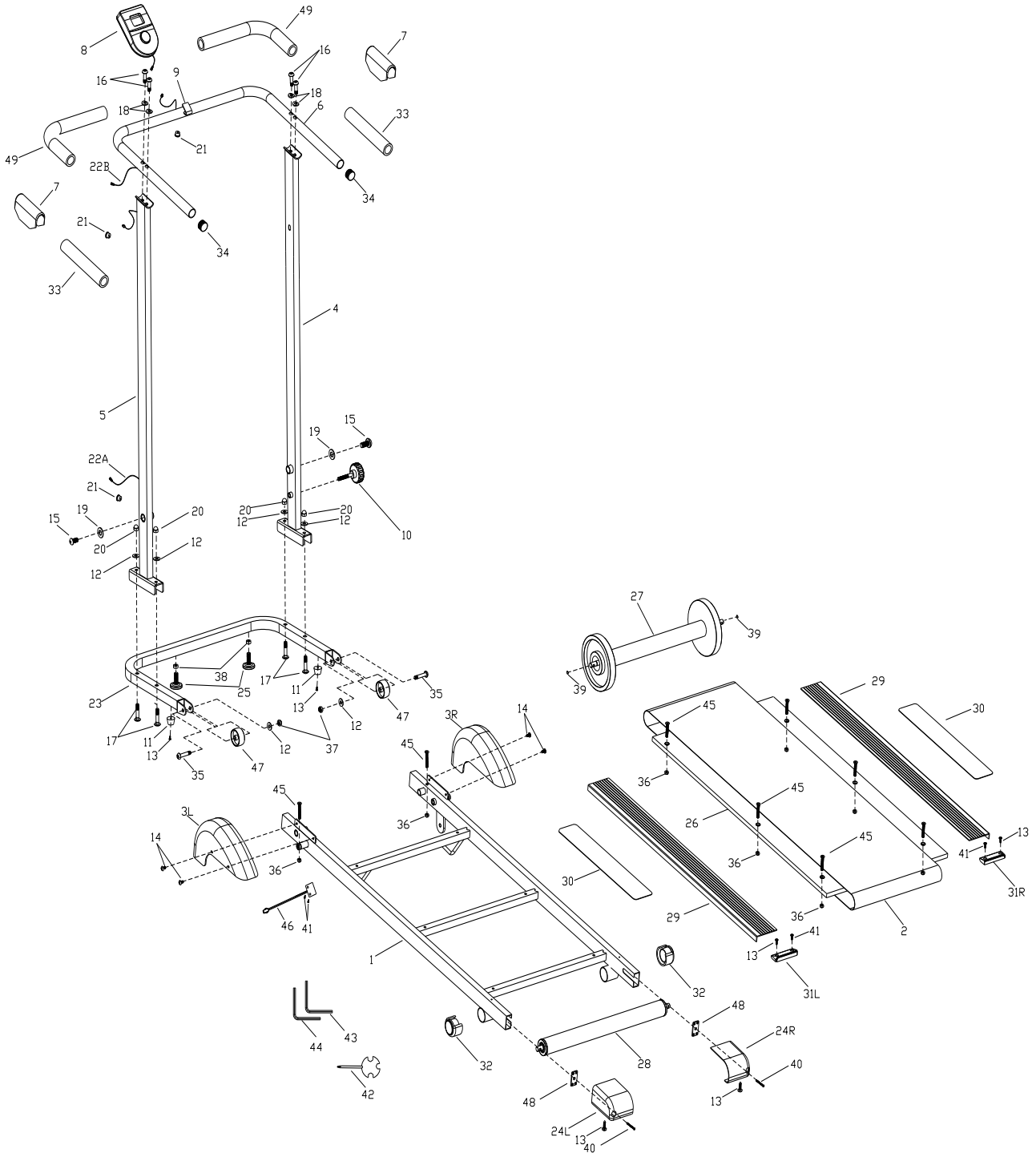

PART LIST

No	Name	QTY	NO	Name	Qty
1	Main frame	1	25	Adjustable feet pad	2
2	Running belt	1	26	Running deck	1
3L	Left flywheel cover	1	27	Front roller	1
3R	Right flywheel cover	1	28	Rear roller	1
4	Right upright support	1	29	Side rail	2
5	Left upright support	1	30	Anti-slip cloth	2
6	Handlebar	1	31L	Left side rail block	1
7	Decorated cover	2	31R	Right side rail block	1
8	Monitor	1	32	Feet cover	2
9	Monitor holder	1	33	Handlebar foam	2
10	Lock knob	1	34	End plug	2
11	Feet pad	2	35	Hexagon screw M8x40	2
12	Flat washer	6	36	Nylon nut M6	8
13	Philips head screw M4x15	6	37	Nylon nut M8	2
14	Philips head screw M5x10	4	38	Nut M8	2
15	Hexagon bolt M10x20	2	39	Flat washer D12.5	2
16	Allen screw M8x35	4	40	Adjustable bolt M6*55	4
17	Carriage bolt M8x38	4	41	Philips head screw ST3.5*12	4
18	Arc washer D8	4	42	Wrench W/screw driver 13*14*15	1
19	Flat washer D10	2	43	Allen wrench S6	1
20	Domed nut M8	4	44	Allen wrench S5	1
21	Plug	3	45	Cross screw M6*45	8
22A	Lower sensor wire	1	46	Sensor wire	1
22B	Upper sensor wire	1	47	Transportation wheel	2
23	Base frame	1	48	Plate for rear roller	2
24L	Rear end cover L	1	49	Handlebar foam	2
24R	Rear end cover R	1			

ASSEMBLY INSTRUCTION

STEP: 1

Note: To complete steps that involve assembling heavy or awkward components, have a second person hold the component(s) in place while you perform the installation. For your safety, do **NOT** attempt to complete these steps on your own.

Attach the **Right & Left Upright Supports (No. 4 and No. 5)** to the **Main Frame (No. 1)** using 2 **Flat Washers (No. 19)** and 2 **Hexagon Bolts (No. 15)**, tighten securely.

Screw the **Lock Knob (No. 10)** into the holes of the **Right Upright Support (No. 4)** and **Main Frame (No. 1)**.

Secure the **Left and Right Flywheel Covers (No. 3/L and 3/R)** to the **Main Frame (No. 1)** using 4 **Phillips Head Screws (No. 14)**.

Connect the **Lower Sensor Wire (No. 22A)** to **Sensor Wire (No. 46)**.

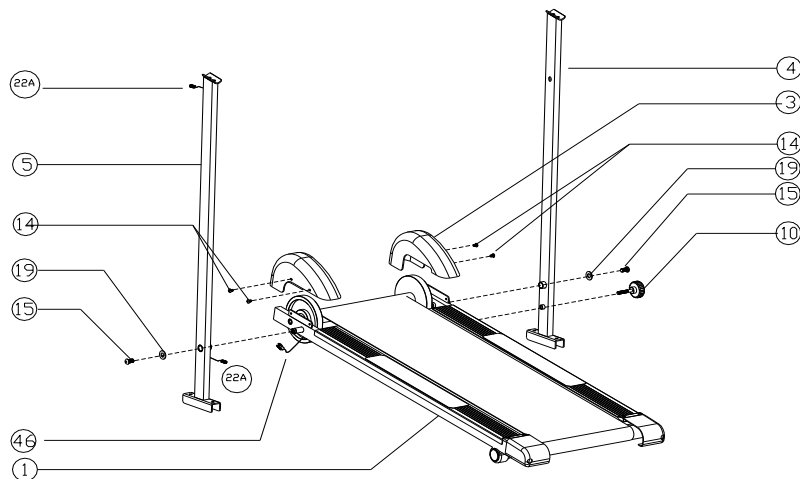

STEP: 2

Secure the **Right & Left Upright Supports (No. 4 and No.5)** to the **Base Frame (No. 23)** using 4 **Carriage bolts (No. 17)**, 4 **Flat Washers (No. 12)** and 4 **Domed Nuts (No. 20)**, tighten securely.

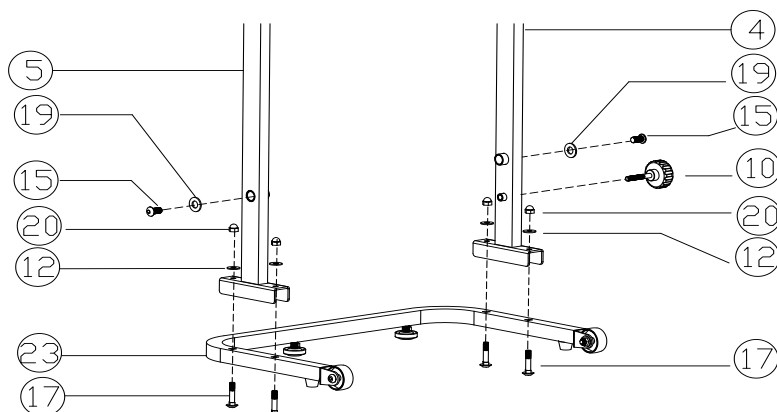

STEP: 3

Fix the **Handlebar (No. 6)** to the **Right & Left Upright Supports (No. 4 and No. 5)** using **Arc Washers (No. 18)** and 4 **Allen Screws (No. 16)**, tighten securely. Next Connect the **Lower Sensor Wire (No. 22A)** to the **Upper Sensor Wire (No. 22B)**.

Open the battery cover of the **Monitor (No. 8)**, insert 2 AA batteries, and close the cover. Connect the **Upper Sensor Wire (No. 22B)** to the **Monitor (No. 8)**, slide the Monitor onto the **Monitor Holder (No. 9)** located on the **Handlebar (No. 6)**.

Place 2 **Decorative Covers (No. 7)** onto the **Handlebar (No. 6)**.

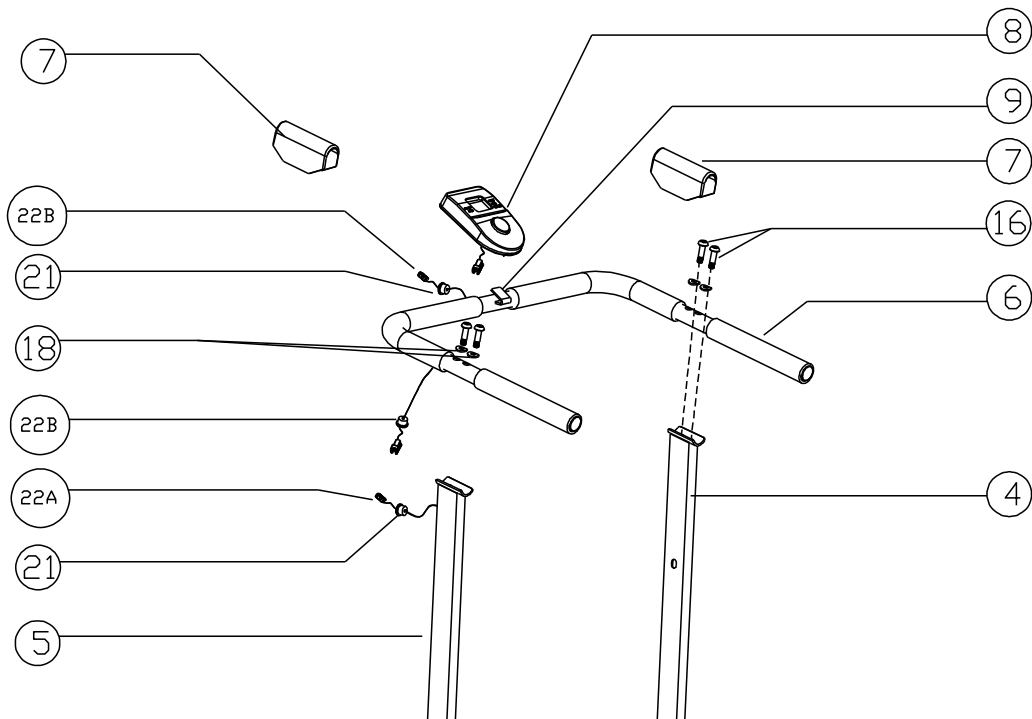

FOLDING INSTRUCTIONS

Folding: To fold up the treadmill, turn the **Lock Knob (No. 10)** counter-clockwise and remove it from the lower hole of the **Right Upright Support (No. 4)**. Raise the rear end of the **Main Frame (No. 1)** all the way up to a vertical position, then insert the **Lock Knob (No. 10)** to the upper hole of **Right Upright Support (No. 4)** and tighten it. (See Below figure).

Unfolding: To unfold the treadmill, turn the **Lock Knob (No. 10)** counter-clockwise and remove it from the upper hole of the **Right Upright Support (No. 4)**. Hold the rear end of the **Main Frame (No. 1)** and lower it all the way down to the ground, insert the **Lock Knob (No.10)** into the lower hole of the **Right Upright Support (No. 4)** and turn clockwise to tighten.

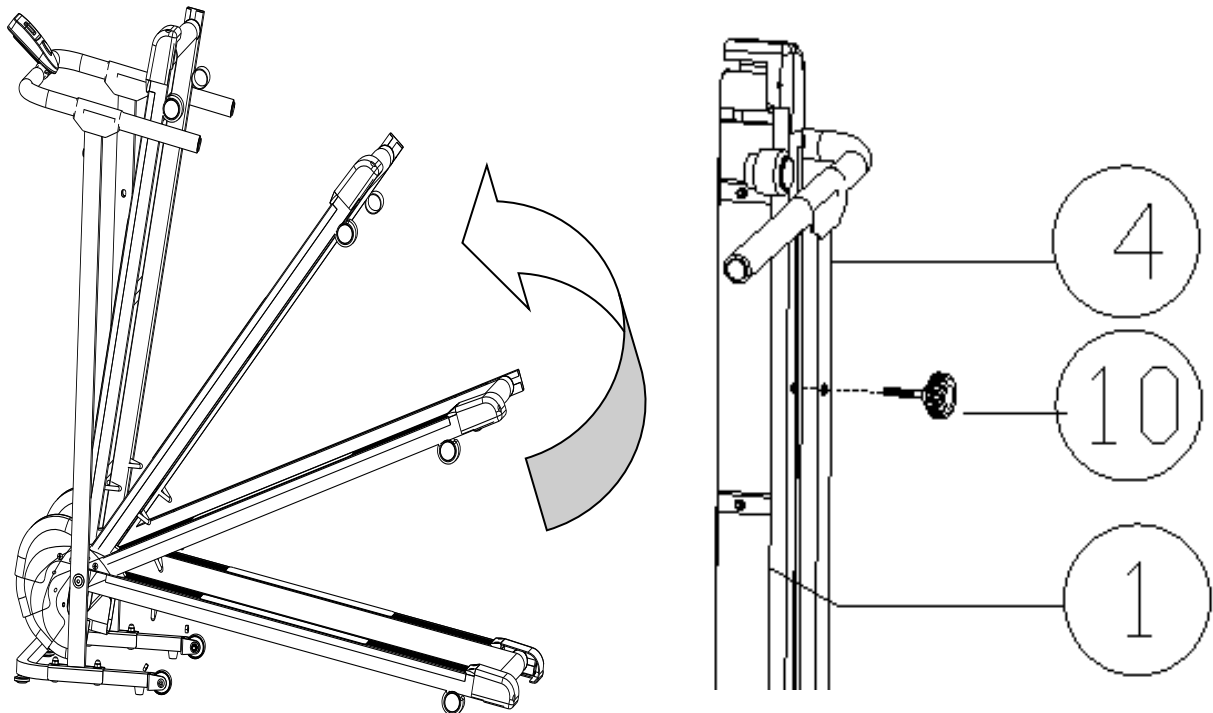

Warning:

1. When folding or unfolding the equipment, always ensure that the **Lock Knob (No. 10)** is inserted correctly, and properly tightened.
2. For their safety, children should be kept away from the equipment, even when folded.

HOW TO MOVE THE MACHINE

Before attempting to move the treadmill please make sure that it has been properly folded.

Moving: Hold the **Handlebar Foams (No. 33)** with your hands, slowly tilt the treadmill back towards your body, once the **Transportation Wheels (No. 47)** touch the ground you can safely move the treadmill to your desired location. (See below figure).

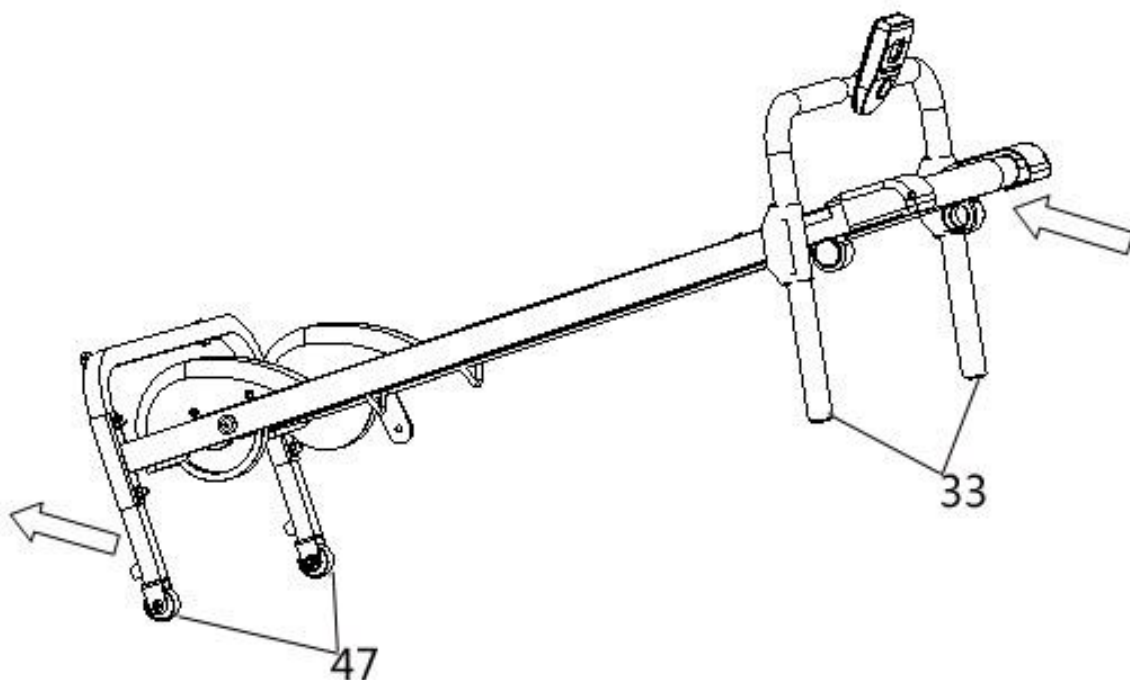

EXERCISE COMPUTER

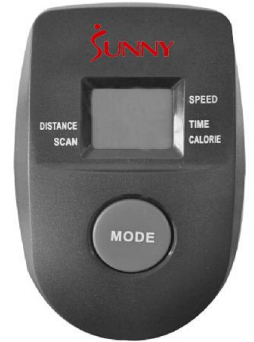

SPECIFICATIONS:

TIME-----	00:00-99:59 MIN: SEC
SPEED-----	0.0-999.9 ML/H
DISTANCE-----	0.00-99.99 ML
CALORIES-----	0.00-999.9 KCAL

FUNCTION KEY:

MODE: Press to select function. (Time, Speed, Distance, Calories).

-Press and hold the MODE button for three seconds to reset time, distance and calories.

OPERATION PROCEDURES:

1. AUTO ON/OFF:

If you start walking or press the mode button, the monitor will turn on. After about 4 minutes of inactivity, the monitor will automatically shut off.

2. RESET:

The computer can be reset by pressing and holding the MODE button for three seconds. Removing the batteries will also reset the computer and return all function settings back to zero.

3. MODE:

To select the LOCK MODE setting press the MODE key when the pointer on the function you wish to select begins to blink, (once locked only the selected function will be displayed).

4. FUNCTIONS:

TIME: Counts the total time of an exercise from start to finish.

SPEED: Displays the current speed.

DISTANCE: Counts the total distance of an exercise from start to finish.

CALORIES: Counts the amount of total calories burned during an exercise from start to finish.

SCAN: Automatically displays functions in the following order shown; time, speed, distance, calories (repeat).

Battery: This monitor uses two AA batteries. If there is a problem with the display, try changing the batteries. Change both batteries. Do not mix battery types. Do not mix old and new batteries. Dispose old batteries according to your state and regional guidelines.

MAINTENANCE INSTRUCTIONS:

General cleaning will help to prolong the life of the treadmill and improve performance. Keep the unit clean and maintained by dusting the components on a regular basis, cleaning the two exposed sides of the running belt to prevent dust from accumulating underneath the belt. Keep your running shoes clean so that dirt from the shoes doesn't wear the running board and belts out. Clean the surface of the running belt using a clean damp cloth.

CENTERING THE RUNNING BELT:

1. If the **Running Belt (No. 2)** moves to the right, turn the **Adjustable Bolt (No. 40)** on the right side $\frac{1}{4}$ turn **clockwise**, then turn the left **Adjustable Bolt (No. 40)** $\frac{1}{4}$ turn **counter-clockwise**. If the belt does not move repeat this step until it centers.

2. If the **Running Belt (No. 2)** moves to the left turn the **Adjustable Bolt (No. 40)** on the left side $\frac{1}{4}$ of a circle **counter-clockwise**, then turn the right **Adjustable Bolt (No. 40)** turn **clockwise**. If the belt does not move repeat this step until it centers.

3. Over time the **Running Belt (No. 2)** will loosen. To tighten the belt, turn the **Left & Right side Adjustable Bolts (No. 40)** one full turn **clockwise**, then check the tension of the belt. Continue this process until belt is at the correct tension. Make sure to adjust both sides equally to ensure correct belt alignment.

During exercise, if the belt feels like it's slipping or loose, you can tighten the belt a little by rotating both **Adjustable Bolts (No. 40)** at the same time $\frac{1}{4}$ turn **clockwise**. If the belt feels unsmooth and too tight, you can loosen the belt by rotating both **Adjustable Bolts (No. 40)** at the same time $\frac{1}{4}$ turn **counter-clockwise**. You can repeat this adjustment to obtain your desired belt tightness.

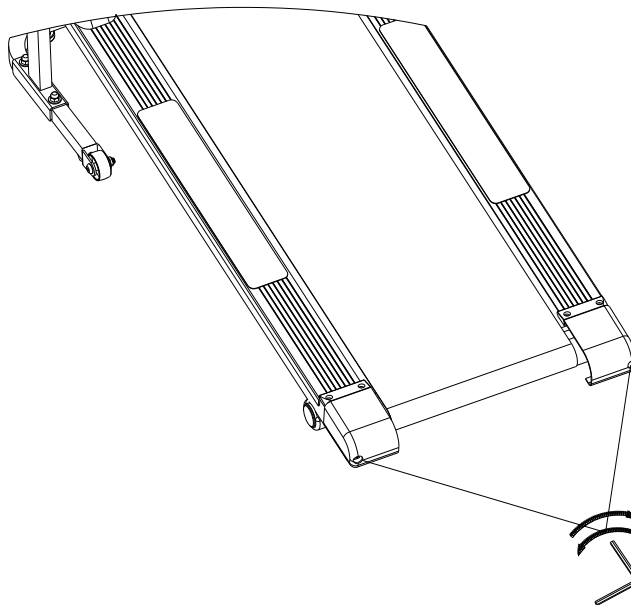

RUNNING BELTS & TREADMILL LUBRICANT:

Lubricating the running board and running belt is essential, as the friction between the two affect the life span and function of the treadmill. Therefore it is suggested that the running board and belt be inspected regularly. Should you find any wear on the running board, please contact us at support@sunnyhealthfitness.com

The following time table is recommended:

Light user (less than 3 hours/ week)	once a year
Medium user (3-5 hours/ week)	every six months
Heavy user (more than 5 hours/ week)	every three months

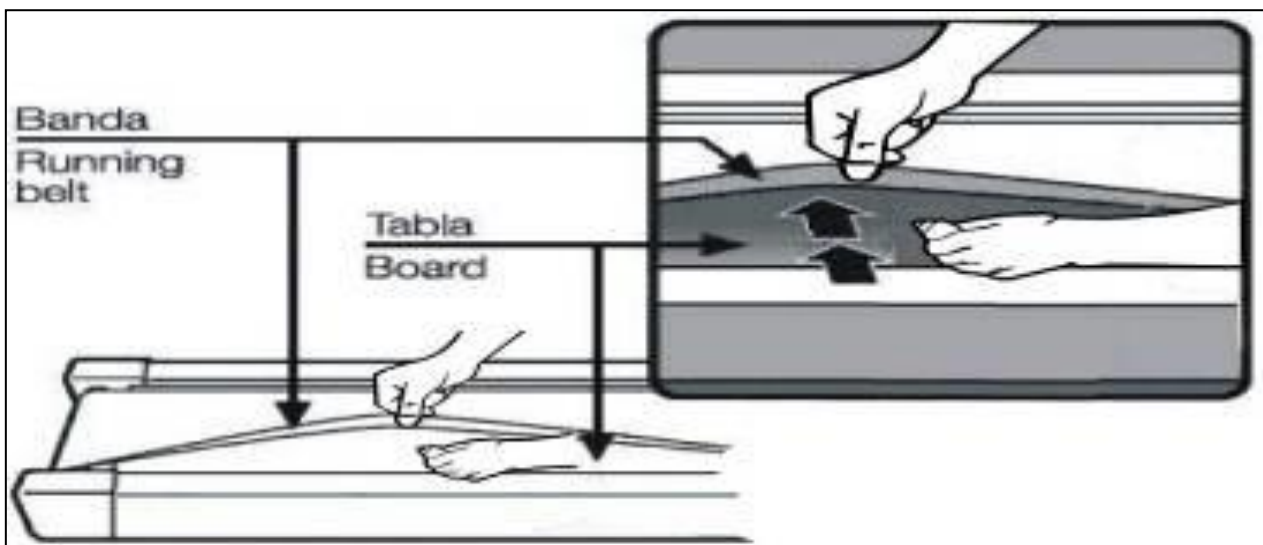

1. Raise the belt up on one side, apply lubricant to the running deck, using a rag thoroughly wipe the lubricant over the running deck; repeat the same process for the other side.
2. The moving parts should turn freely and quietly. Abnormality of moving parts will affect the safety of the equipment. So checking and tightening bolts in each part of the equipment regularly is very important.
3. To better maintain the treadmill and prolong its life it is suggested that maintenance be done on a regular and consistent basis.
4. A loose **Running Belt** will result in the runner sliding off when running, while too tight of a **Running Belt** will result in decrease to the motors performance and also create more friction between the roller and running belts. The most suitable tightness for the belts is pulled out **50-75mm** from the **Running Board**.

TROUBLESHOOTING

PROBLEM	CAUSE	CORRECTION
Base is unstable	There is an object under the Main Frame of the treadmill or the ground isn't level.	Remove the object Move the treadmill to level ground
	The Lock Knob is loose	Tighten the Lock Knob
Noise from moving parts	Hardware; nuts bolts or screws are loose	Inspect hardware and tighten.
	Running Belt and Board are not lubricated	Lubricate Running Belt and Board see (Pg. 10)
Running belt not centered	Running belt tension not Proper on the left or right sides of the running board	Adjust the Allen Bolts; refer to Maintenance (Pg. 9) Centering the Running Belt.
The Monitor screen does not display clearly.	The batteries are low	Replace the batteries with new ones
The Monitor doesn't work at all.	One of the following sensor wires isn't connected correctly. The Sensor Wire (No.46) Lower Sensor Wire (No. 22A) or Upper Sensor Wire (No. 22B)	Check the connections of the sensor wires, make sure connects are proper
	The Batteries are dead	Replace with new batteries

EXERCISE INSTRUCTIONS

GETTING STARTED:

Before starting any exercise program you should consult your physician to determine if you have any medical or physical conditions that could put your health and safety at risk, or prevent you from using the equipment properly. Be aware of your body's signals. Incorrect or excessive exercise can damage your health. Stop exercising immediately if you experience any of the following symptoms: pain, tightness in your chest, irregular heartbeat, and extreme shortness of breath, lightheadedness, dizziness or feelings of nausea.

A good exercise program consists of a warm-up, aerobic exercise, and a cool down. Do the entire program at least two to three times a week, resting for a day between workouts. After several months you can increase your workouts to four or five times per week.

The **WARM-UP** is an important part of any workout. It should begin every session to prepare your body for more strenuous exercise by heating up and stretching your muscles, increasing your circulation and pulse rate, and delivering more oxygen to your muscles.

COOL DOWN at the end of your workout, repeat these exercises to reduce soreness in tired muscles.

HEAD ROLLS

Rotate your head to the right for one count, feeling the stretch up the left side of your neck, then rotate your head back for one count, stretching your chin to the ceiling and letting your mouth open. Rotate your head to the left for one count, and then drop your head to your chest for one count.

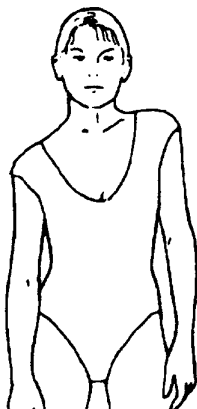

SHOULDER LIFTS

Lift your right shoulder toward your ear for one count. Then lift your left shoulder up for one count as you lower your right shoulder.

SIDE STRETCHES

Open your arms to the side and lift them until they are over your head. Reach your right arm as far toward the ceiling as you can for one count. Repeat this action with your left arm.

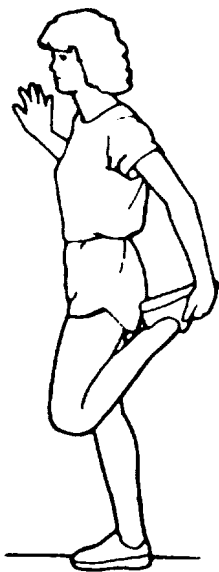
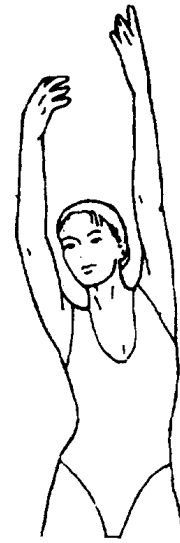

QUADRICEPS STRETCH

With one hand against a wall for balance, reach behind you and pull your right foot up. Bring your heel as close to your buttocks as possible. Hold for 15 counts and repeat with left foot.

INNER THIGH STRETCH

Sit with the soles of your feet together and your knees pointing outward. Pull your feet as close to your groin as possible. Gently push your knees toward the floor. Hold for 15 counts.





TOE TOUCHES

Slowly bend forward from your waist, letting your back and shoulders relax as you stretch toward your toes. Reach as far as you can and hold for 15 counts.

HAMSTRING STRETCHES

Extend your right leg. Rest the sole of your left foot against your right inner thigh. Stretch toward your toe as far as possible. Hold for 15 counts. Relax and then repeat with left leg.

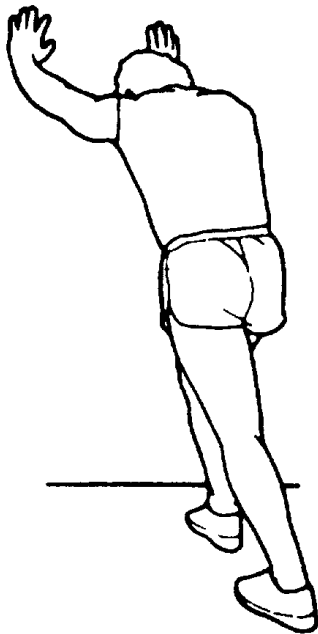
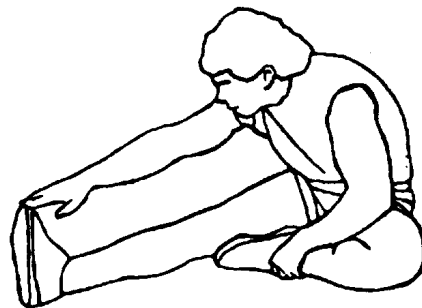

CALF/ACHILLES STRETCH

Lean against a wall with your left leg in front of the right and your arms forward. Keep your right leg straight and the left foot on the floor; then bend the left leg and lean forward by moving your hips toward the wall. Hold, then repeat on the other side for 15 counts.