



Assembly Instruction Sheet
Item # 355-2X
Breakfast Cart Drop Leaf Table

Before You Begin

Check to make sure you have the following :

FOR CART

LIST OF WOODEN PARTS

Part	Description	Qty.
A	Drop-Leaf Table Top	1
B	Side Panels	2
C	Middle Panel	1
D	Bottom Panel	1
E	Cross Supports	2
F	Leaf Support	1
G	Towel Bars	2

LIST OF HARDWARES PARTS

Part	Description	Qty.
SC10003	Screws JCA 1/4" x 32	16
SC10019	Screws F6 x 1"	4
SC10004	Screws F6 x 5/8"	16
WD40001	Wood Plugs	8
CA40092	Casters Lock	2
CA40093	Casters Free	2
CA40091	Dowel Caster Lock	1
TL40015	Hexagonal Wrench	1

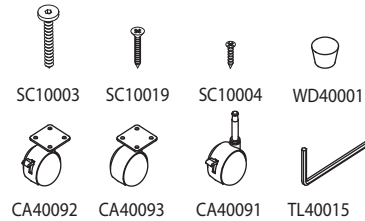

FOR DRAWERS

LIST OF PARTS

Part	Description	Qty.
H	Front Panels	2
I	Side Panels	4
J	Back Panels	2
K	Bottom Panels	2

LIST OF HARDWARE PARTS

Part	Description	Qty.
SC10002	Screws F6 x 1 1/4"	2
WD40096	Dowel Stoppers	4
WD40008	Handle Knobs	2
SC10019	Screws F6 x 1"	16

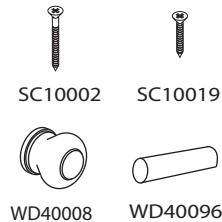

FOR STOOLS

LIST OF PARTS

Part	Description	Qty.
L	Side Panels	4
M	Seats	2
N	Round Strip (Long)	4
O	Round Strip (Short)	4

List of Hardware Parts

Part	Description	Qty.
SC10003	Screws JCA 1/4" x 32	16
WD40001	Wood Plugs	16

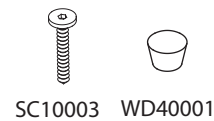

Tools

You will need the following:

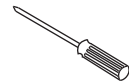

Phillips
screwdriver

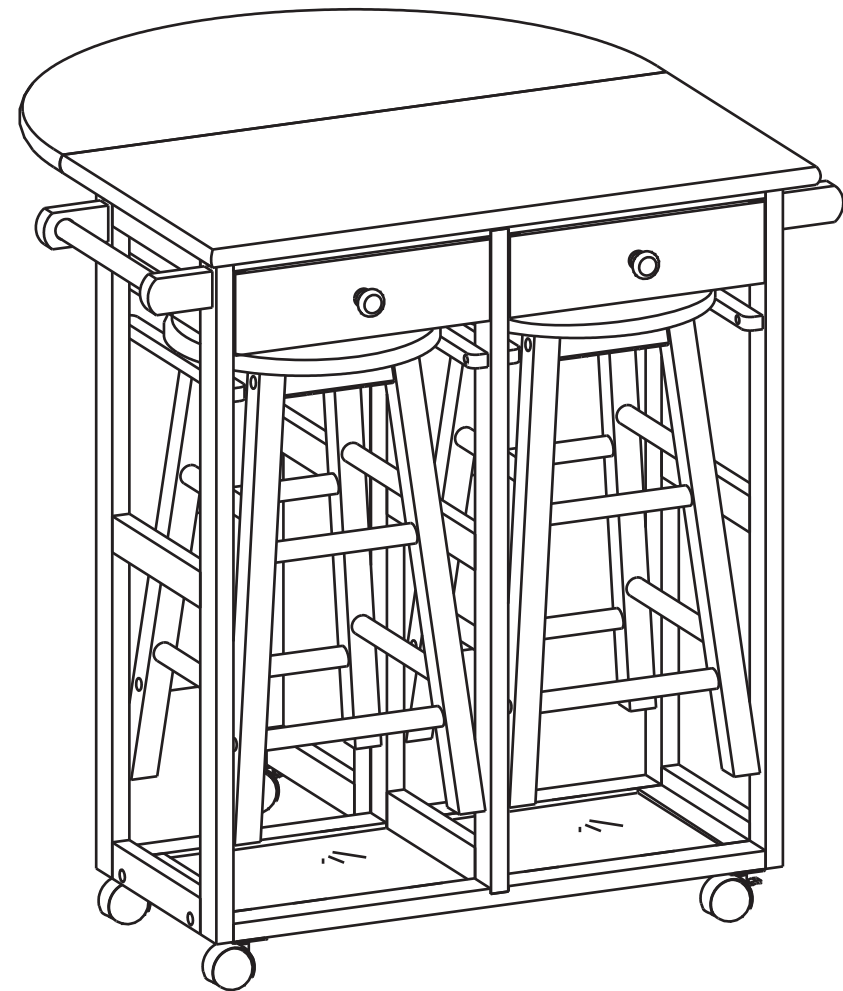

COMPLETE

Breakfast Cart Drop Leaf Table

Assembly



To store Bar Stool, slide seats between hanging rails .

Assembly

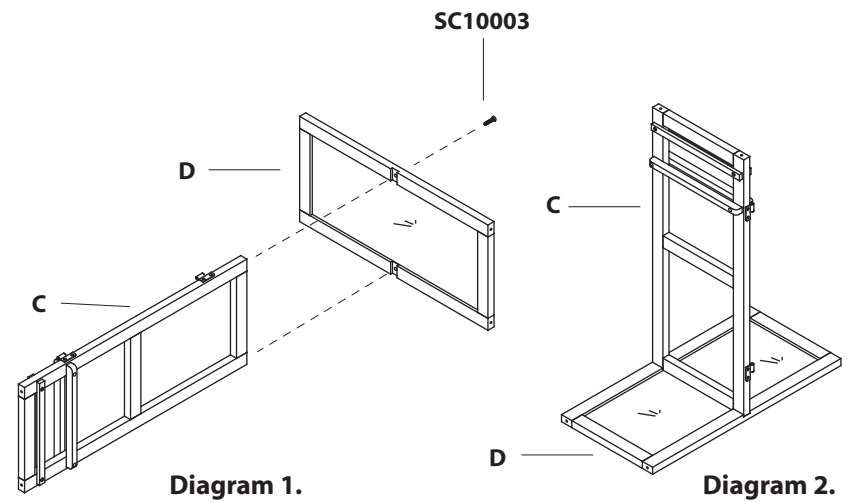

Step 1 : Attach middle panel (C) to bottom panel (D) with 2 screws JCA 1/4" x 32 (SC10003), as show in Diagram 1. and turn right side up as show in Diagram 2.

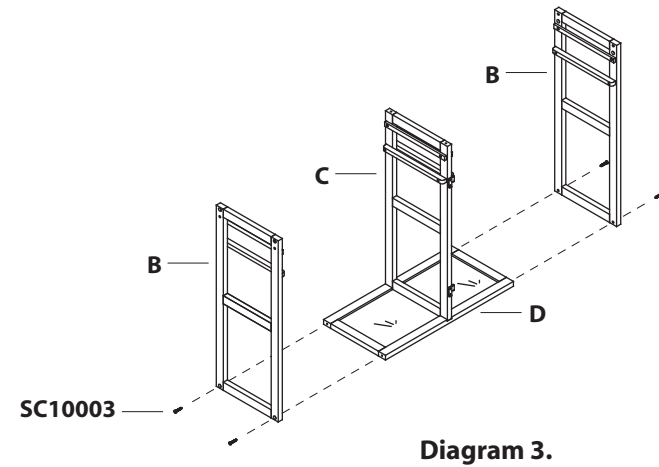

Step 2 : Attach both side panel (B) with 4 screws JCA 1/4" x 32 (SC10003), as show in Diagram 3.

Assembly

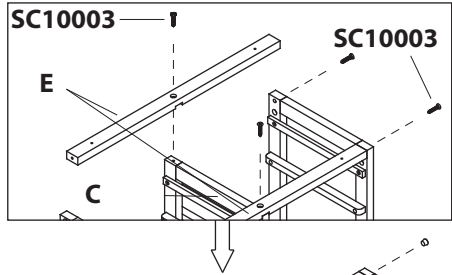

Step 3 : Attach cross supports (E) to middle panel (C) at the middle with 2 screws JCA 1/4" x 32(SC10003). Then that attach both ends of cross supports (E) to left and right panels with 8 screws JCA 1/4" x 32 (SC10003) and cover the screws with wood plugs (WD40001),as show in Diagram 4.

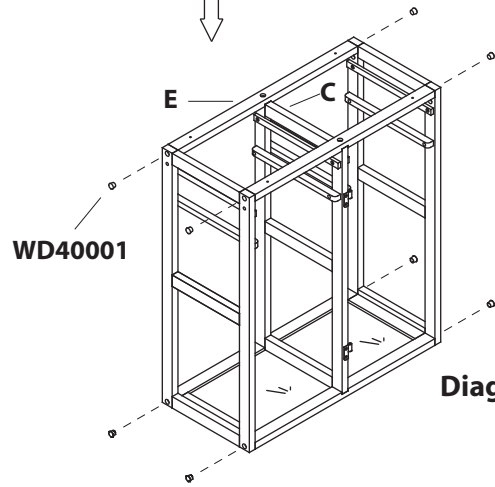

Diagram 4.

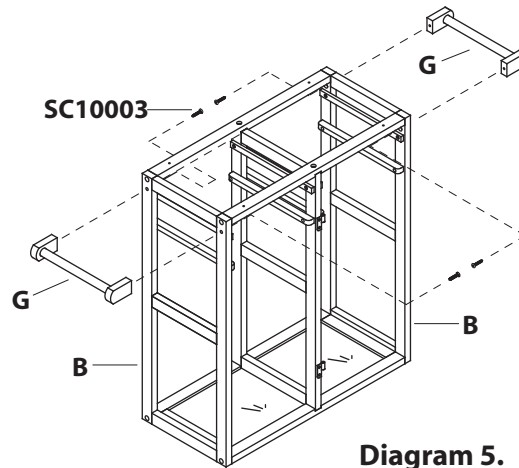

Diagram 5.

Step 4 : Attach towel bars (G) to left and right panels (B) with 4 screws JCA 1/4" x 32(SC10003) as show in Diagram 5.

Assembly

INSTALL DRAWER

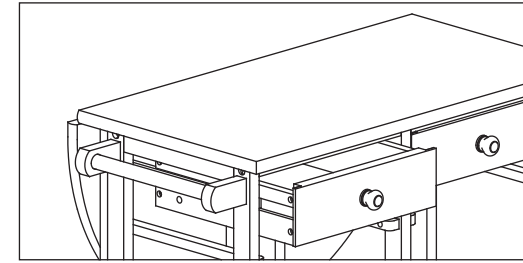

Diagram 13.

Step 1 : Align grooves on both sides of drawer with wood tracks and slide drawer in, as show in Diagram.13.

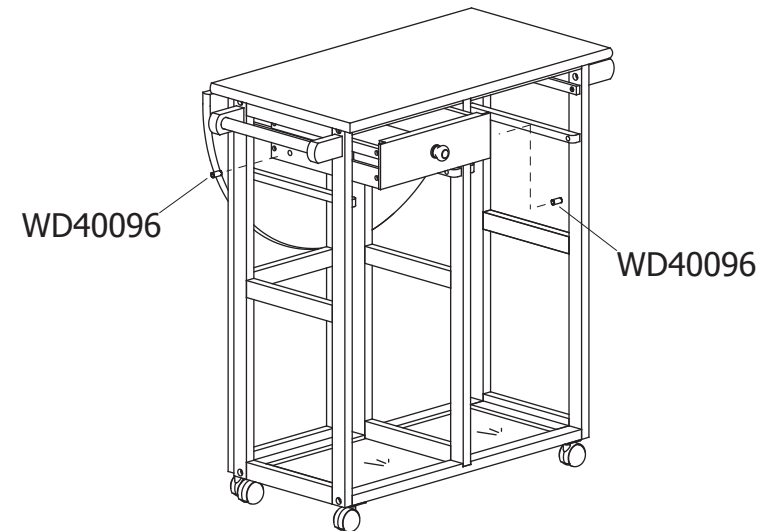

Diagram 14.

Step 2 : Slide a drawer half way into the space saver, insert drawer stopper (WD40096) into holes for both side the drawer, as show in Diagram.14.

Assembly

DRAWER ASSEMBLY INSTRUCTIONS

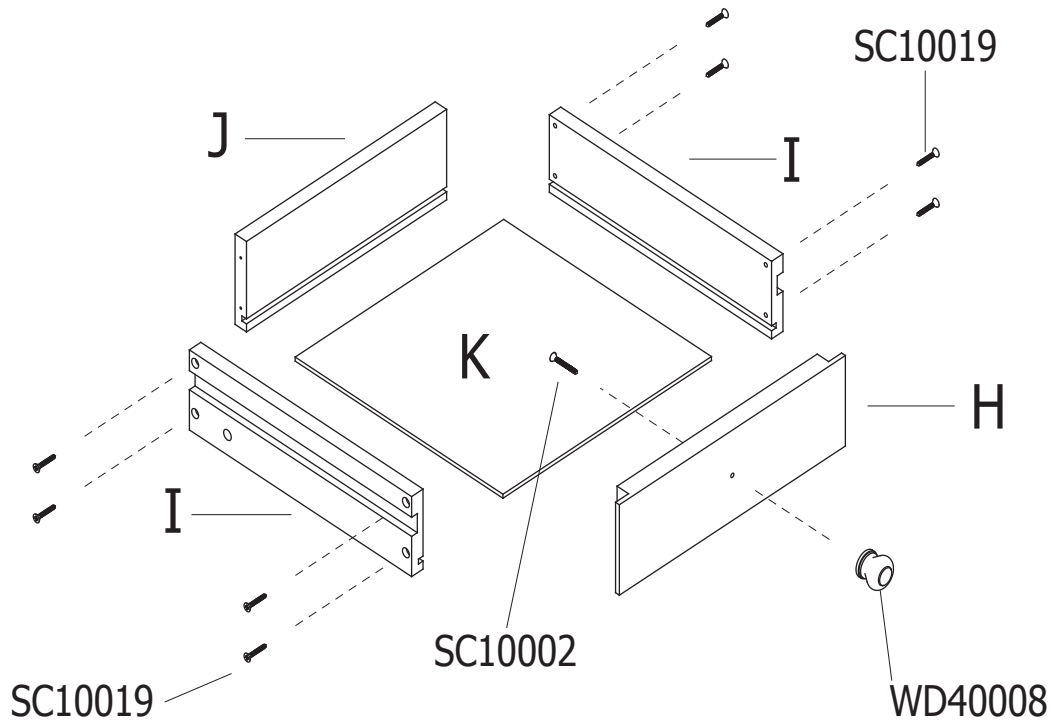

Diagram 12.

Assembled drawers by attaching sides (I), back (J), and bottom (K) to the front panel (H) using 8 screws F6 x 1" (SC10019). Attach the handle knob (WD40008) to front panel (H) with screw F6 x 1 1/4" (SC10002) as show in Diagram .12.

Assembly

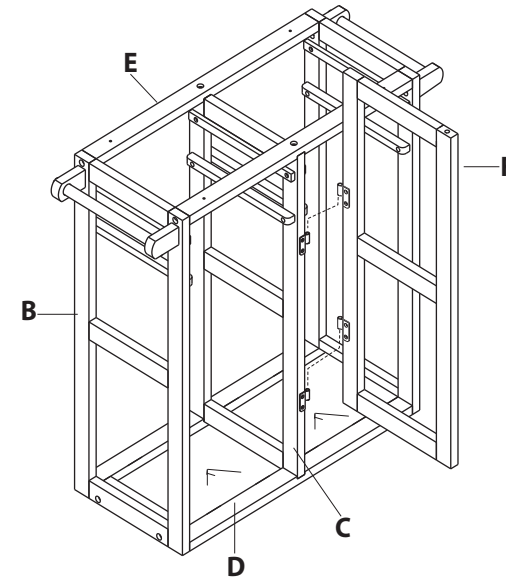

Diagram 6.

Step 5 : Align the hinges on leaf support (F) and middle panel (C), slip hinge pivots into anchors, as show in Diagram 6.

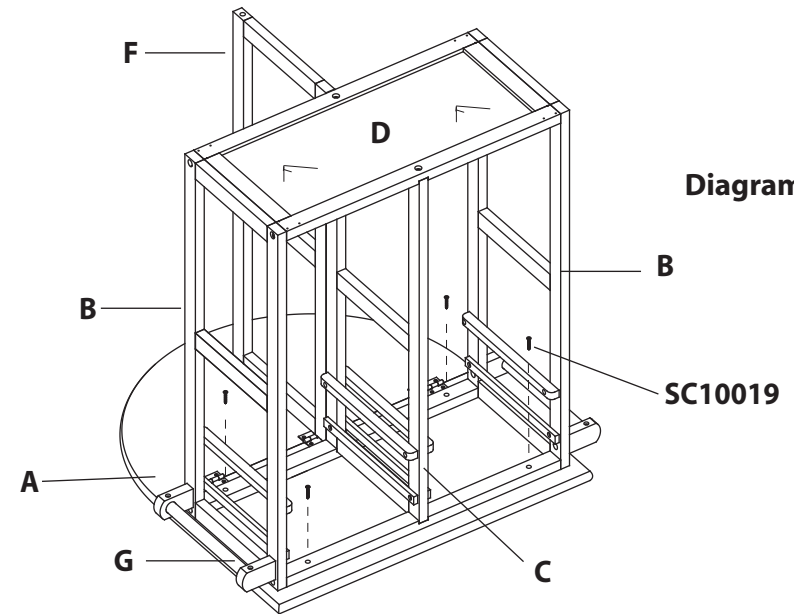

Diagram 7.

Step 6 : Invert drop-leaf table top (A) on a soft surface to prevent scratching of the top. Align screws holes in top frame to holes under drop-leaf top and secure with 4 screws F6 x 1" (SC10019), as show in Diagram 7.

Assembly

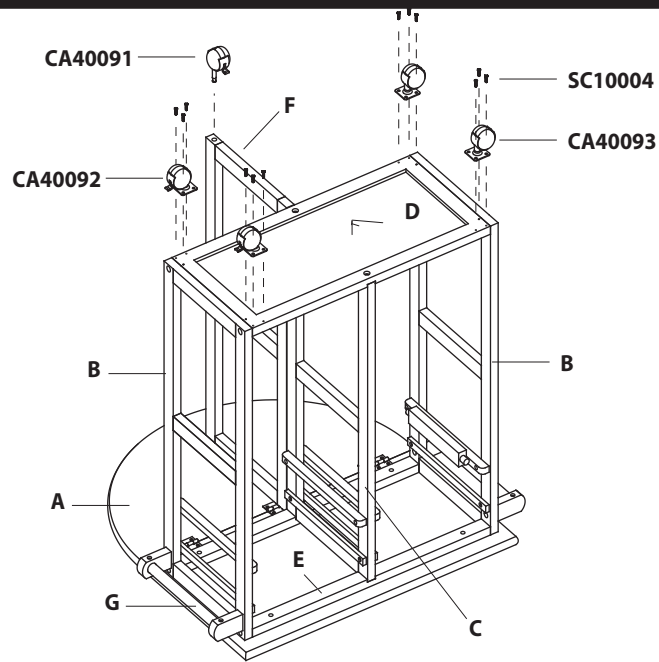
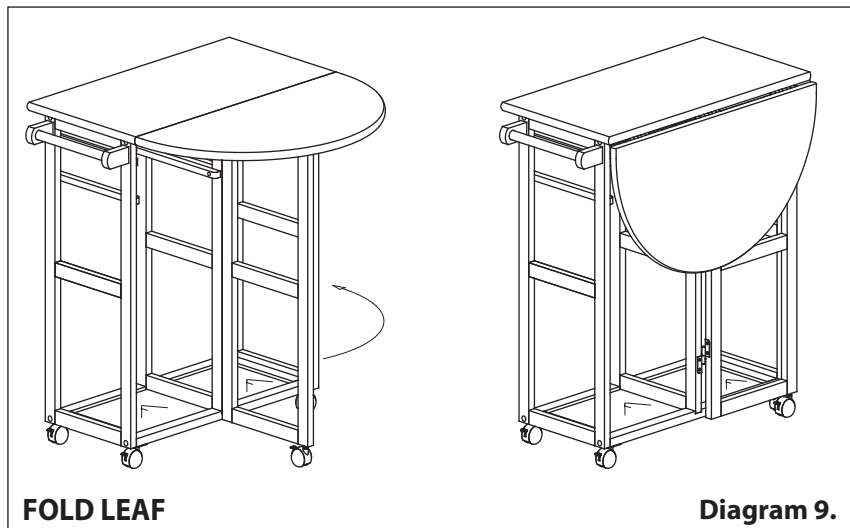

Diagram 8.

Step 7 : Attach 2 casters Lock (**CA40092**), 2 casters free (**CA40093**) to bottom panel (**D**) with 16 screws F6 x 5/8" (**SC10004**) and insert dowel caster lock (**CA40091**) into the holed of leaf support (**F**) as shown in Diagram 8.



Assembly

BAR STOOL ASSEMBLY INSTRUCTIONS

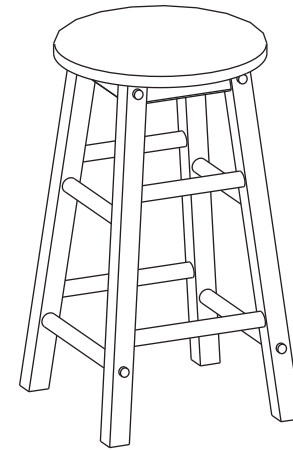

Diagram 10.

Step1: Lay the seat (**M**) on floor and insert one side panel(**L**).

Step2: Insert and fasten short and long round strip (**N,O**) using screws JCA 1/4" x 32 (**SC10003**), as show in Diagram 11.

CAUTION : DO NOT OVER TIGHTEN SCREWS UNTIL UNIT IS COMPLETELY ASSEMBLED.

Step3: Attach other side panel and fasten screws.

Step4: Tighten screws by using Hexagonal Wrench (**TL40015**) provided.

Step5: Cover all holes with wood plugs (**WD40001**).

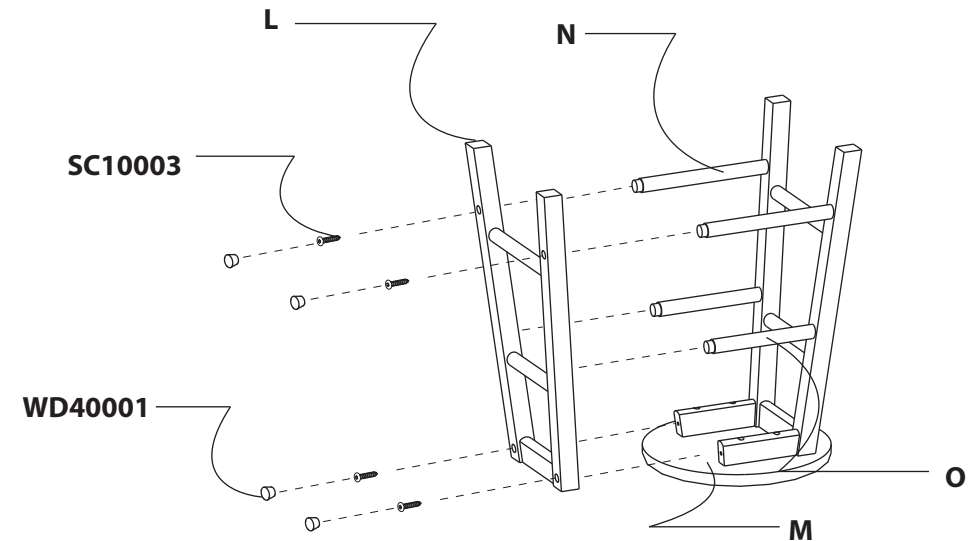

Diagram 11.