

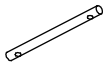



Hardware List

ITEM	DESC	PART	QTY	ITEM	DESC	PART	QTY
A	CONNECTING ROD	 6X80MM	8pcs	D	WOOD DOWEL	 6X30MM	20pcs
B	SCREW	 4X12MM	16pcs	E	ALLEN WRENCH		1pc
C	ALLEN HEAD SCREW	 5X45MM	28pcs				

Part List

ITEM	PART	QTY	ITEM	PART	QTY
1	 LEFT BACK UPPER LEG	1pc	9	 TOP CONNECTION BAR	1pc
2	 LEFT BACK LOWER LEG	1pc	10	 1ST SHELF PANEL (TOP PANEL)	1pc
3	 LEFT FRONT UPPER LEG	1pc	11	 2ND SHELF PANEL	1pc
4	 LEFT FRONT LOWER LEG	1pc	12	 3RD SHELF PANEL	1pc
5	 RIGHT BACK UPPER LEG	1pc	13	 4TH SHELF PANEL (BOTTOM PANEL)	1pc
6	 RIGHT BACK LOWER LEG	1pc	14	 SHORT UPPER RAIL	2pcs
7	 RIGHT FRONT UPPER LEG	1pc	15	 LONG LOWER RAIL	2pcs
8	 RIGHT FRONT LOWER LEG	1pc			

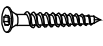
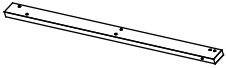
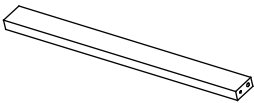
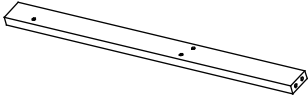
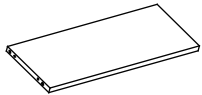
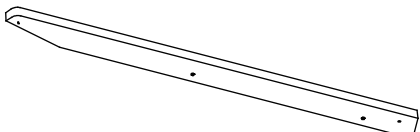
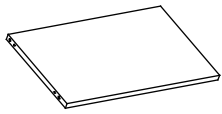
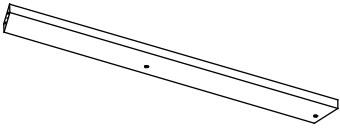
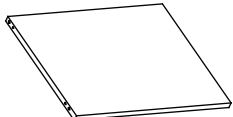
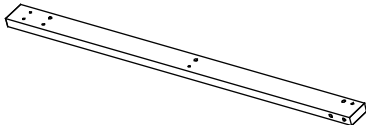
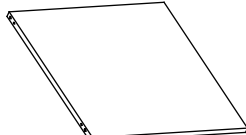
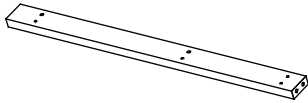
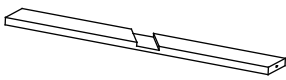
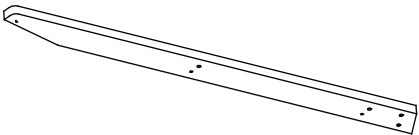
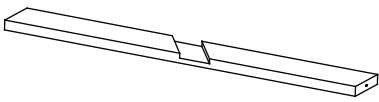
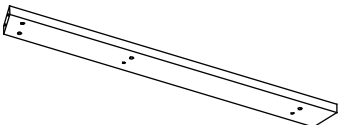
STEP 1

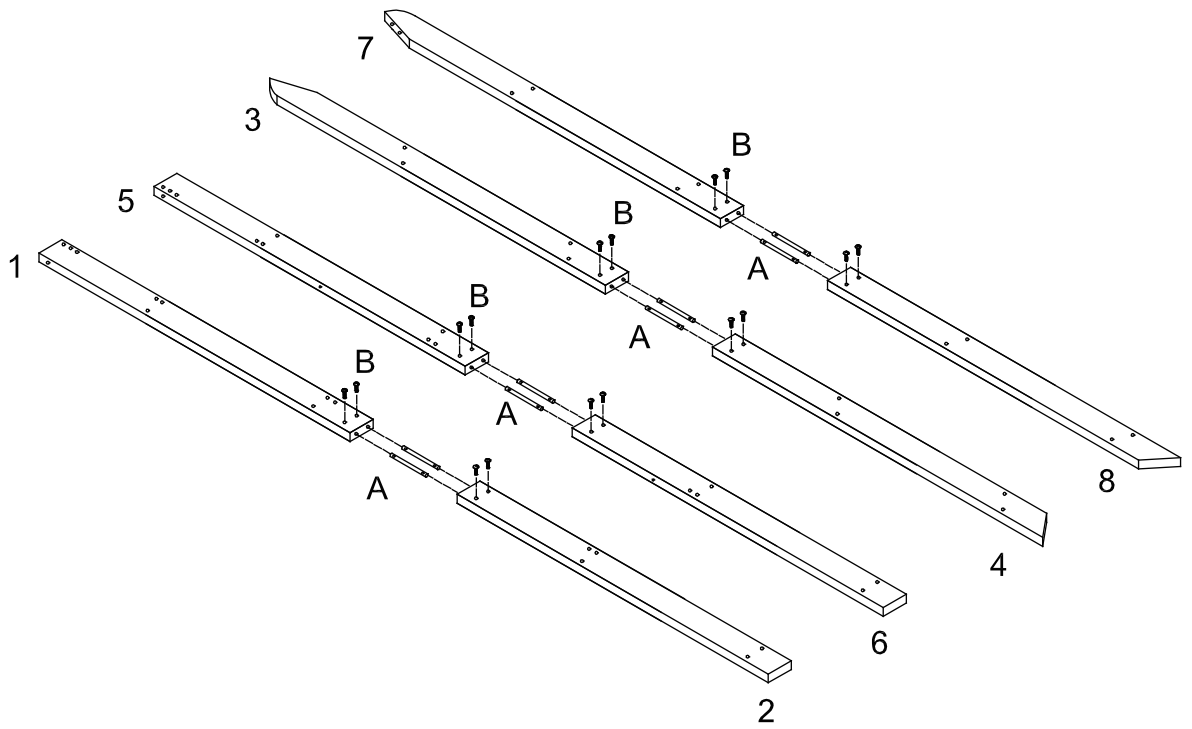

STEP 2

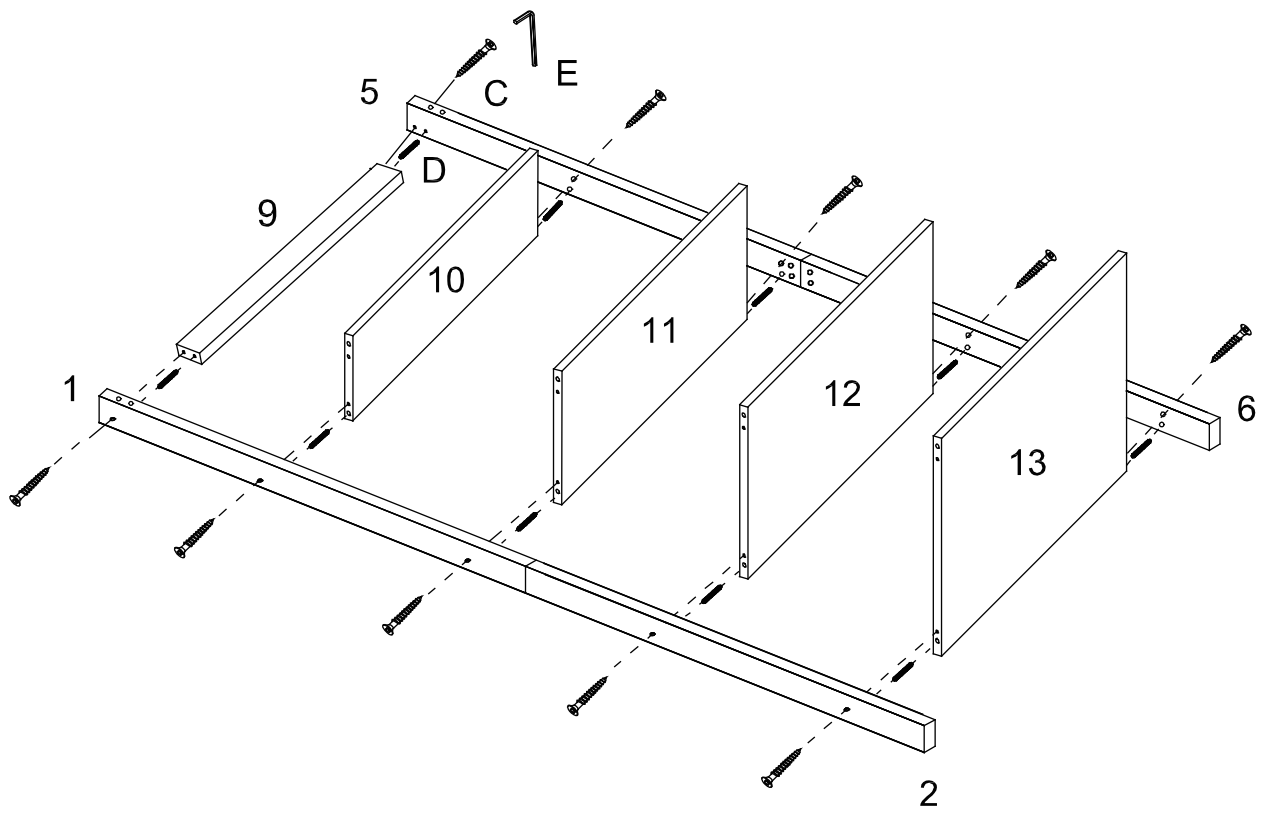

STEP 3

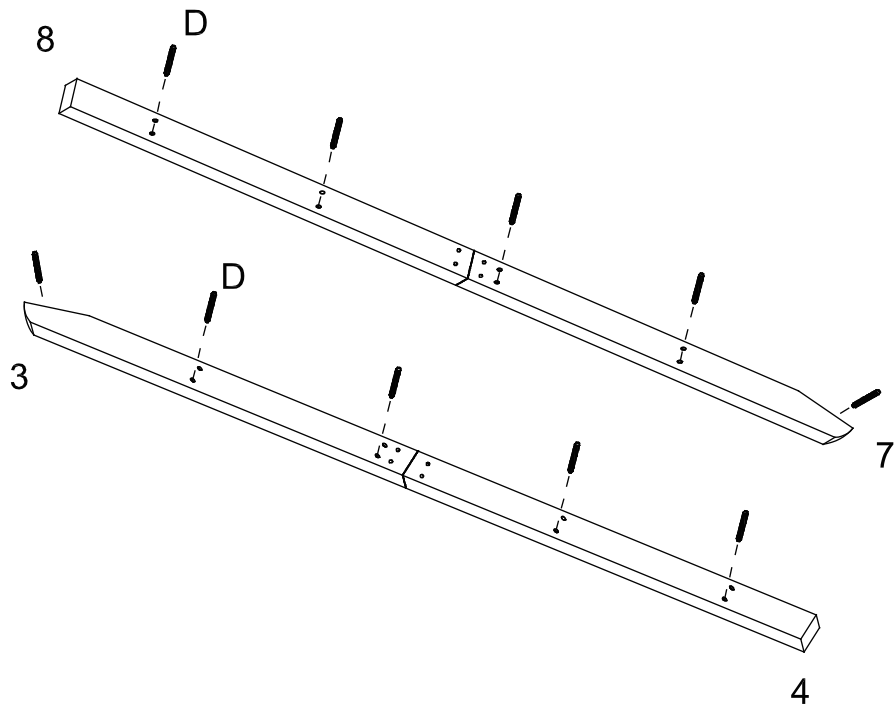

STEP 4

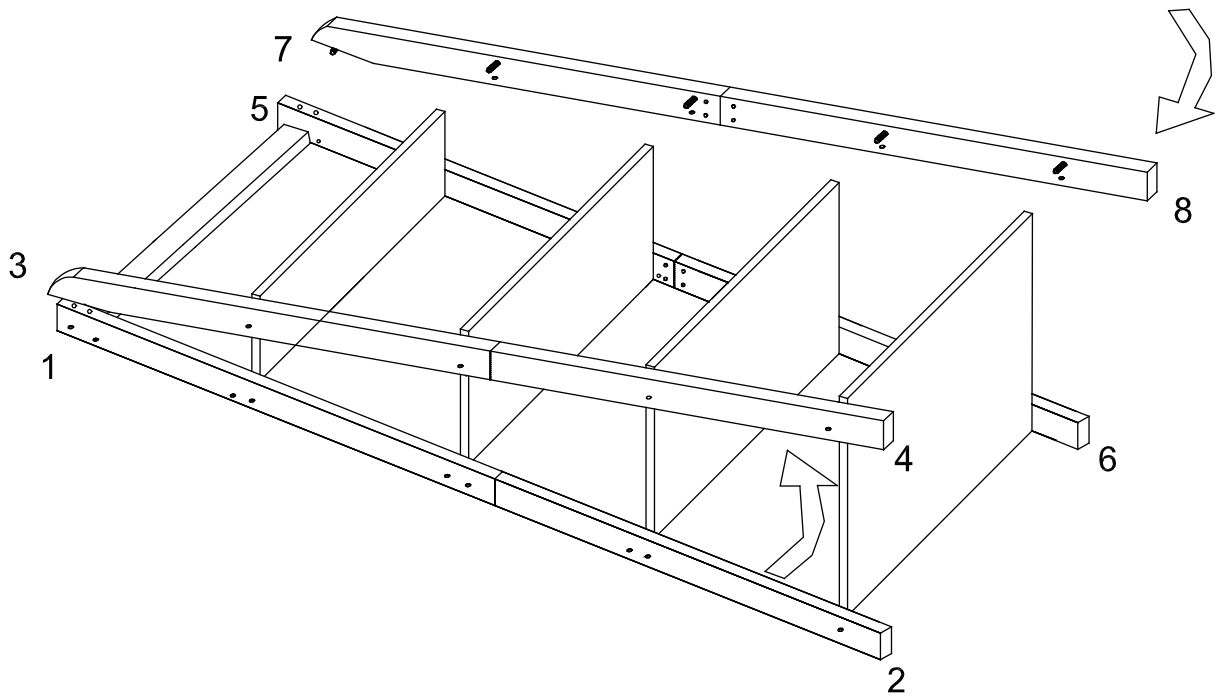

STEP 5

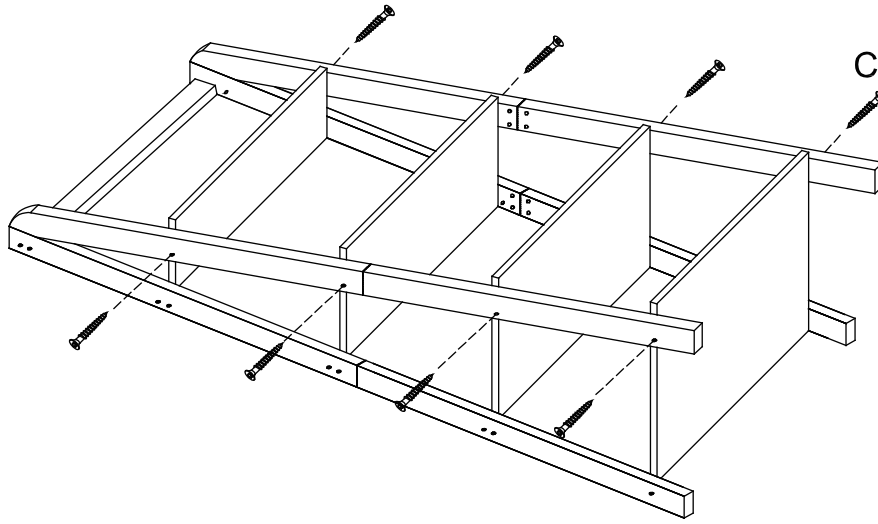

STEP 6

