

ONDURA-9™

9-Corrugation Asphalt Roofing Sheets

I N S T A L L A T I O N I N S T R U C T I O N S

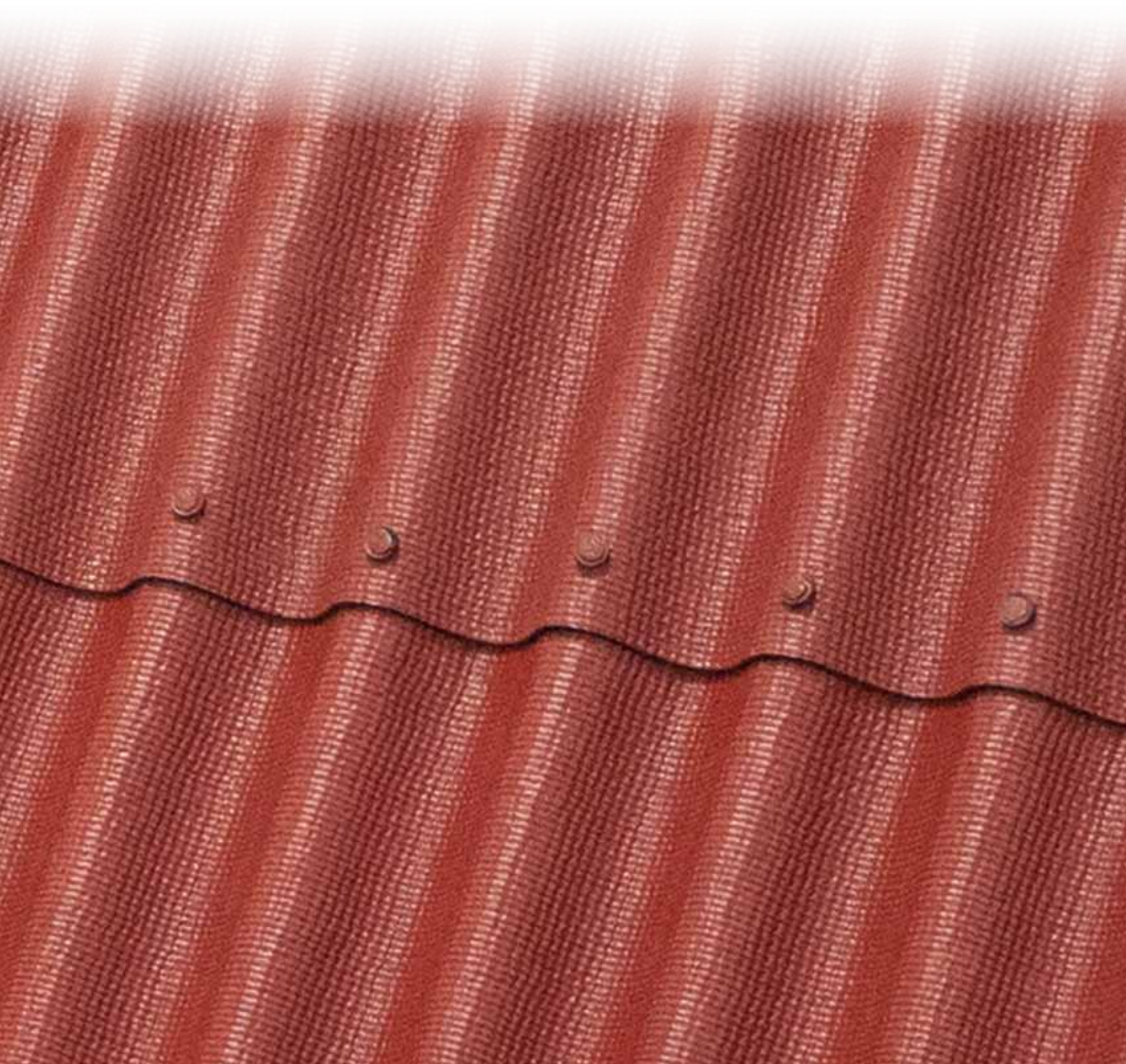

Thank you for choosing ONDURA-9 for your roofing project. ONDURA-9 should be carefully installed. Mistakes in installation can cause roof problems later on. Please take your time and closely follow these installation guidelines.

CAUTION

Installation of roofing materials can be dangerous. The relative amount of danger is increased by the height from the ground, increasing pitches of the roof slope, inclement weather conditions or other factors. We strongly recommend for anyone installing ONDURA-9, or working on a roof in any manner, to take all precautions possible to ensure your personal safety at all times.

Be sure that ladders and other such devices are safely positioned and properly secured. OSHA recommends the use of a safety harness when applying roofing. Protective eyewear is recommended when applying nails or using power tools. ONDURA-9 may be slippery when wet, dusty, frosty or oily, so please avoid working or walking on the roof if any of these conditions exist. Windy conditions can make the worksite more dangerous, so we recommend that you do not attempt to install ONDURA-9 during windy conditions.

TOOLS AND MATERIALS

You will need the following tools and materials:

- Claw Hammer
- Utility Knife
- Saw (Hand Saw or Circular Saw)
- Measuring Tape or Yardstick
- String
- Pencil or Marker
- Protective Eyewear

ESTIMATING GUIDE FOR ONDURA 9

Sheet dimensions: 36 inches wide by 79 inches long

Sheet Coverage

For projects requiring multiple sheets, account for overlaps in calculating roof coverage (see diagram below).

- Sidelap should be at least one corrugation (4 inches per corrugation).
- Headlap should be at least 7 inches.
- The effective sheet coverage is 32 inches wide by 72 inches long.

Fasteners

- Fasteners needed per sheet: 17 min./24 max. for 3 rows of fasteners, with rows spaced approximately 24 inches apart.
- Fasteners for roof ridge: 6 fasteners per foot of ridge (3 on each side).
- Fasten sheets on every corrugation at rake edge, eaves, and overlaps. For other fastener rows you may fasten on every corrugation or on every other corrugation. Fastening on every corrugation provides better wind resistance.
- Fasten ridge caps at every corrugation.

Ridge Caps

Ridge cap sections should overlap by at least 7 inches.

Closure Strips

Closure strips are 44 inches long, with four strips per pack. Closure strips should be used at roof ridge and eaves.

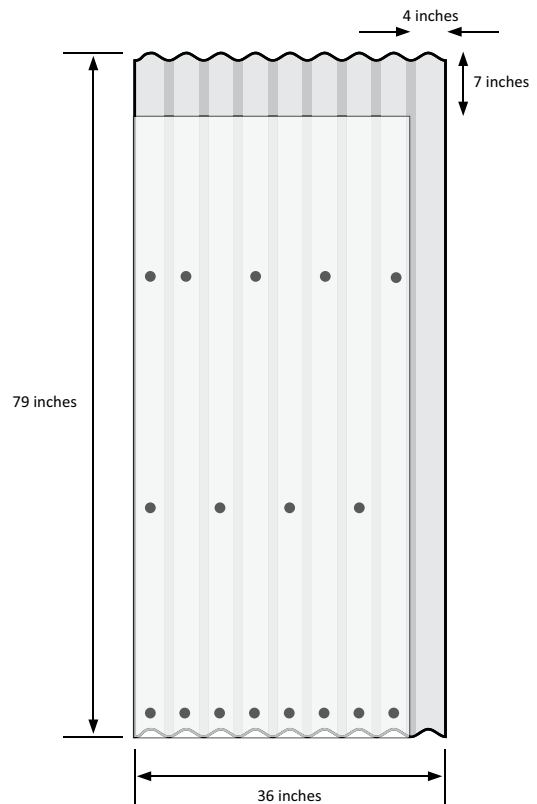

PLANNING STAGE

Determine the Slope of the Roof

The slope of the roof can be calculated from measurements of the rise and run of the roof. The rise is the vertical distance of the ridge above the eave. The run is the horizontal distance of the ridge from the eave. A roof slope is often stated as the inches of vertical rise per 12 inches of horizontal run length. The minimum appropriate slope for an ONDURA-9 roof is a 3 inch rise over a 12 inch run.

Slope = amount of rise per run
Example: 3-in rise per
12-in run = 3:12
Minimum slope required: 3:12

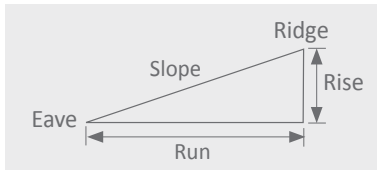

Note: At the ridge of the roof, the gap across the ridge, between the upper ends of the ONDURA-9 sheets on each side of the roof, will be covered by the ridge cap; and the gap should be no more than two inches.

If your roof is wider than 36 inches, then you will need to account for the single corrugation overlap for adjacent ONDURA-9 sheets. The first ONDURA-9 sheet will provide 36 inches of coverage. Each additional ONDURA-9 sheet will provide 32 inches of coverage with one corrugation overlap.

Rake Edge

The rake edge of the roof should be covered to prevent water intrusion or damage to the sheathing. The rake edge should be covered with drip edge flashing. The drip edge flashing goes over the felt paper on the rake edge and under the ONDURA-9 sheet.

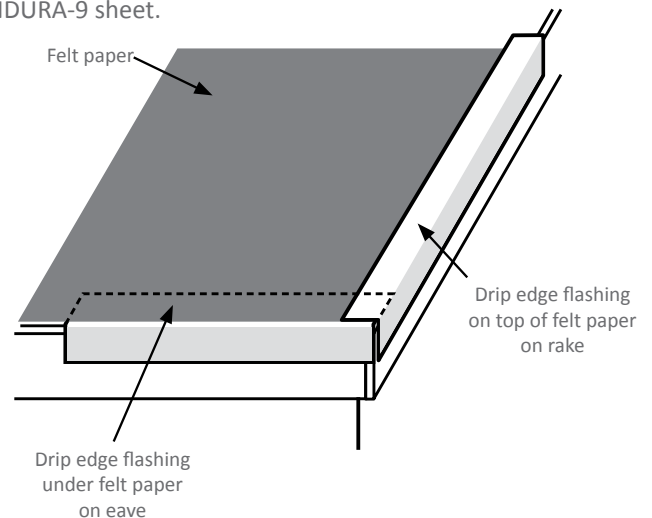

Roof Sheathing

Roof sheathing is a plywood or OSB (oriented strandboard) layer on top of the roof supports. If your roof has sheathing, we recommend using standard felt paper or an ice water shield over the sheathing.

Purlins

If your roof has purlins instead of sheathing, then the maximum purlin spacing is 24 inches on center. If your roof may be exposed to heavy snow loads, then the purlin spacing should be reduced to 12 inches on center.

On-Site Storage

While stored at the job site, ONDURA-9 sheets must be covered to protect from damage that may be caused by rainwater trapped between sheets. Do not allow stacked sheets to get wet while stored.

Roof Coverage

ONDURA-9 sheets are 36 inches wide and 79 inches long. We recommend an overhang at the roof eave of 1 to 1-3/4 inches (Note: 1-3/4 inches is the maximum overhang relative to the edge of the roof sheathing). Measure the roof from eave to ridge and add the overhang length to determine the total length of coverage.

If the total length of coverage is greater than 79 inches, then you will need a second row of ONDURA-9 sheets. The sheet overlap from row to row should be at least 7 inches.

Cutting ONDURA-9 Sheets

Always wear eye protection when cutting.

- To cut an ONDURA-9 sheet parallel to the corrugations, use a utility knife with a sharp blade. Always cut sheets in the valley of a corrugation with the painted side up.
- To cut an ONDURA-9 sheet perpendicular to the corrugations, use a circular saw with a carbide-tipped blade or a hand saw. Apply a lubricating oil on the saw blade to aid in a smoother cut. For best results, work with the painted side down and mark the cut line with a pencil on the unpainted side.

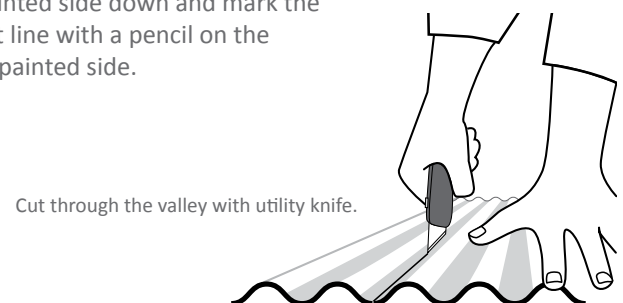

Placement of ONDURA-9 Sheets

If more than one row of ONDURA-9 sheets is needed, then the sheets must be installed along the eave first. Then additional rows are installed above the previous row.

Each row should be installed with the first sheet at the opposite end of the roof from the prevailing winds. With this orientation, the seam of the overlap will face away from the prevailing winds. This orientation will reduce the possibility of wind-driven rain getting under the corrugation overlap. If wind-driven rain could come from both directions, then we recommend sealing along the overlap with an elastomeric caulk.

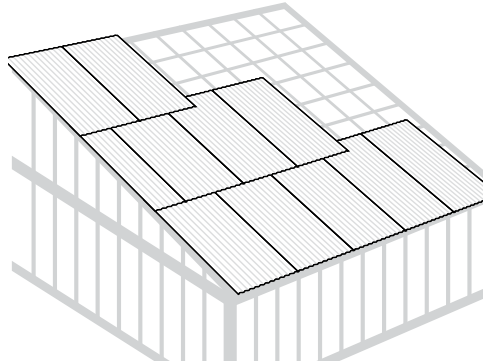

For aesthetic reasons, we recommend staggering the position of the corrugation overlap for each row by starting the second row with a sheet that has fewer corrugations. As a general guide, an ONDURA-9 sheet with 4 or 5 corrugations should be used for the first sheet on the second row. Then full-width sheets should be used across the second row. If installing more than 2 rows, the odd numbered rows should start with a full-width sheet and the even numbered rows should start with a 4 or 5 corrugation sheet.

If possible, we recommend placing the first row of ONDURA-9 sheets on the roof to confirm coverage with overlaps before the installation of the sheets.

Closure Strips

ONDURA closure strips fill the space created by the corrugations. Vented closure strips are recommended along the eaves and ridge of the roof to enable airflow under the corrugations. The ventilation holes are small enough to prevent birds and insects from forming nests under the corrugations. Solid ONDURA closure strips are available to completely block the openings under the corrugations.

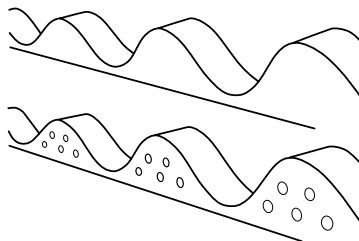

Note: ONDURA closure strips fit the ONDURA-9 sheets. We do not offer a different set of closure strips for ONDURA-9 sheets. Each closure strip is 44 inches long.

INSTALLATION STAGE

Sheet Alignment

Place first ONDURA-9 sheet on roof. Align the ONDURA-9 sheet to the rake edge. Align the eave edge of the ONDURA-9 sheet to overhang the eave by 1 to 1-3/4 inches.

Closure Strip Position

Place closure strips under the ONDURA-9 sheet with the curved side up to fill the corrugations. The closure strips must be placed where the nails will be located so that the nails will securely hold the closure strips in place during the life of the roof.

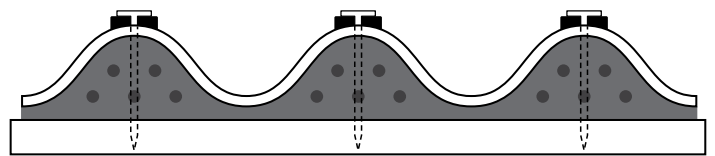

Nail Position

Note: We recommend genuine ONDURA nails for installing ONDURA-9 sheets. Genuine ONDURA nails are made from galvanized steel, are ring shanked, and have a large EPDM rubber washer to improve sealing around the nail. Other types of nails may not provide sufficient hold-down strength.

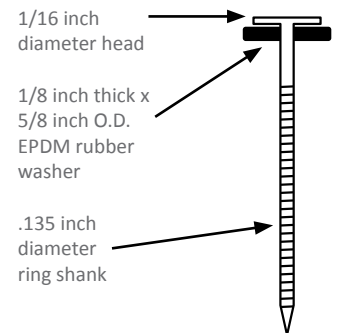

Drive each ONDURA nail only through the crown of a corrugation and perpendicular to the roof surface. Be careful not to overdrive or underdrive the nail. The rubber washer on the nail should be snugly in contact with the sheet. Slight hand pressure on a nailed-down corrugation should not separate the sheet from washer contact.

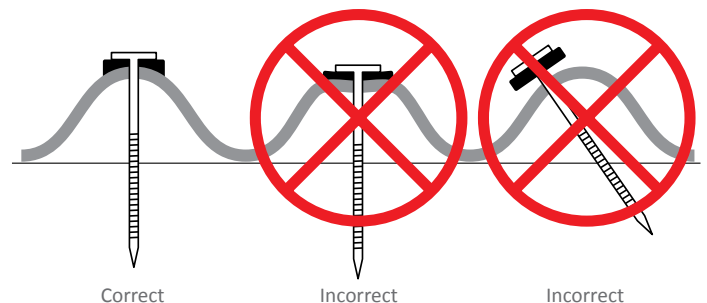

Measure distance along the sheet corrugation from eave edge of sheet to outer wall of structure. The lower line of nails should be installed high enough on the sheet to be on or inside the wall support. The typical distance from the eave edge of a sheet to the outer wall is 2 to 3 inches. For resistance to wind uplift, the maximum distance from the eave edge of a sheet to the first row of nails is 5 inches.

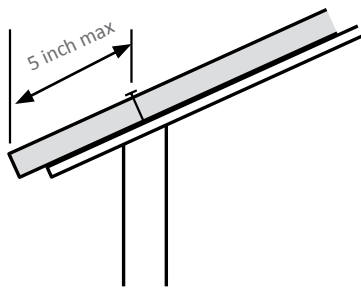

Install nails on the first sheet along the eave and rake edges.

Tip: For each row of nails, install the first two nails at opposite sides of the sheet and attach a string line between them—across the corrugations—as a guide for the position of the other nails. Mark the position of the string on the crown of each corrugation with a pencil. Repeat for each row of nails.

Install nails at remaining positions, but do not fasten areas which will be overlapped by other sheets.

Place next ONDURA-9 sheet into position on roof.

- The sheets must overlap by at least one corrugation along the direction of the eave.
- The sheets should overlap by at least 7 inches along the direction of the rake edge. If installing over purlins, the overlap must be over a purlin so that the nail can be secured into the purlin.

Install nails on sheet in the same manner as the first sheet.

For the last sheet in a row, install nails in the same pattern as previous sheets and in the final corrugation along the rake edge.

Ridge Cap

Note: Install all sheets on both sides of the roof before installing the ridge cap.

Measure the ridge to determine the required coverage. Each ridge cap is 39-1/2 inches long. If more than one ridge cap is needed, they must be installed with a 7 inch overlap. Allow for 3 or 4 inches of material at end of ridge to overhang ridge end. This material will be used to cover the end of the ridge.

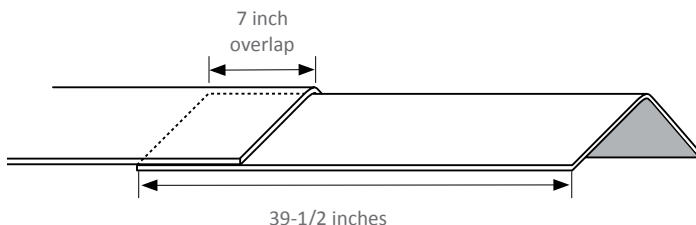

Place the first ridge cap at the end of the ridge away from the prevailing wind, allowing it to project out 3 to 4 inches from the ridge end.

Insert closure strip above ONDURA-9 sheet and below ridge cap. The closure strips must be placed where the nails will be located so that the nails will securely hold the closure strips in place during the life of the roof.

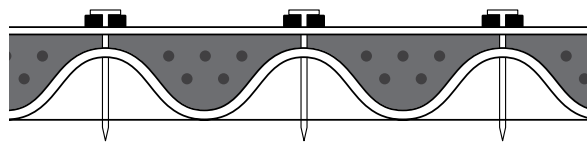

Install nails through the ridge cap and closure strip at every crown of the underlying ONDURA-9 sheets. The row of nails should be 1 inch above the lower edge of the ridge cap. If more than one ridge cap is needed, overlap the next ridge cap before fastening through the overlap.

Place next ridge cap with 7 inch overlap. Insert closure strip and install nails.

Install final ridge cap with 7 inch overlap and 3 to 4 inch overhang. Insert closure strip and install nails.

At each end of the ridge, cut the overhang portion of the ridge cap along the crown with a utility knife. Fold down resulting flaps for a weather guard. Secure flaps to ridge fascia with roofing nails.

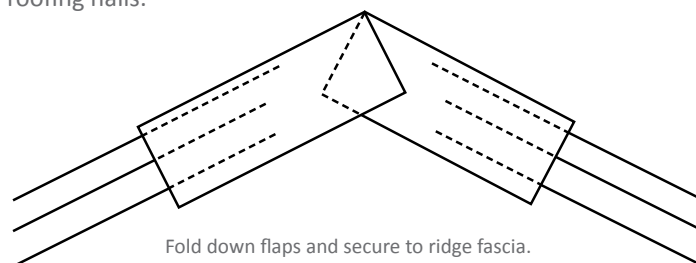

Congratulations! You have completed the installation of your ONDURA-9 roof.

ADDITIONAL TIPS

Pulling Nails

To pull a nail from an ONDURA-9 sheet, use a claw hammer and a 1-1/2 inch wood dowel or pipe. This technique minimizes the chance of damaging the sheet. Put the dowel or pipe in the valley next to the crown where the nail will be pulled. Then use the dowel or pipe as a leverage point for pulling the nail.

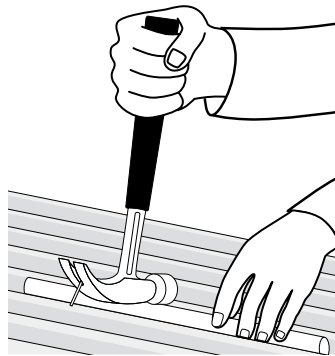

Walking on an ONDURA-9 Roof

When walking on nailed-down ONDURA-9 sheets, wear soft-soled shoes and walk on areas that have structural support from sheathing or purlins. Always place feet across corrugations to distribute your weight and prevent damage to corrugations. ONDURA-9 is more pliable in hot weather and less pliable in cold weather. Always use care when walking on any roof.



4900 Ondura Drive, Fredericksburg, VA 22407

Phone: 800.777.7663 FAX: 540.898.4991

ondura.com

©2016 Onduline North America, Inc. Printed in USA I-AF265EN