



# 9531096



**DO NOT RETURN PRODUCT TO THE STORE**  
Individual stores do not stock parts.

**NO REGRESE EL PRODUCTO A LA TIENDA**  
Las tiendas individuales no proveen de partes de recambio

Lot Number / Número de Lote: \_\_\_\_\_

Date Of Purchase / Fecha de Compra: \_\_\_\_ / \_\_\_\_ / \_\_\_\_

**If a part is missing or damaged, call our toll-free customer service line. We will gladly ship your replacement parts FREE of charge.**

**Si falta partes o las partes están dañadas, llame gratis al servicio del cliente. Nosotros con gusto se las mandaremos las partes que necesite sin recargo alguno.**

Need Parts or Assistance?  
Nesacitas partes o asistencia?

**1-800-489-3351**

or access our website  
o visite nuestra página de internet

**www.altrafurniture.com**

For prompt, reliable service please have your assembly manual ready.  
Para obtener servicio rapido y confiable, por favor tenga esta manual a la mano.

THIS INSTRUCTION BOOKLET CONTAINS **IMPORTANT** SAFETY INFORMATION. PLEASE READ AND KEEP FOR FUTURE REFERENCE.

ESTE FOLLETO DE INSTRUCCION CONTIENE INFORMACION **IMPORTANTE** DE SEGURIDAD. POR FAVOR LEA Y GUARDE PARA REFERENCIA FUTURA.

Recommended # of people needed for assembly: 2

Número recomendado de personas necesarias para el montaje: 2

B34953109601

Thank you for purchasing from Altra Furniture.  
Visit [www.altrafurniture.com](http://www.altrafurniture.com) to view the limited warranty valid in the U.S. and Canada.

## ALTRA FURNITURE CUSTOMER SERVICE

Gracias por haber comprado de Altra Furniture.  
Visite [www.altrafurniture.com](http://www.altrafurniture.com) para mirar la garantía limitada, la cual es válida solamente en U.S.A y Canada.

## SERVICIO A LA CLIENTE DE ALTRA FURNITURE

### Before starting - Antes de empezar.

- Read each step carefully before starting. It is very important that each step of instruction is performed in the correct order. If these steps are not followed in sequence, assembly difficulties will occur.

Leer con cuidado cada paso antes de empezar. Es muy importante de ejecutar cada paso en el orden correcto. Si los pasos no están ejecutados en secuencia, ocurrirá dificultades en el montaje.

- Make sure all parts are included. Most board parts are labeled or stamped on the raw edge. Asegurese de que todos las piezas están incluidas. La mayoría de los tableros tienen las etiquetas o los sellos en las esquinas sin acabado.

- Work in spacious area, preferably on a carpet, near the place the unit will be used. Haga el montaje en una área espaciosa, preferiblemente sobre una alfombra, cerca del lugar donde se va a usar el mueble.

- Have the following tools close at hand. Tenga las siguientes herramientas a mano.

- Do not use power tools to assemble your furniture. Power tools may strip or damage the parts. No use herramienta eléctrica para montar esta unidad. Las herramientas eléctricas pueden dañar las piezas de ensamble.

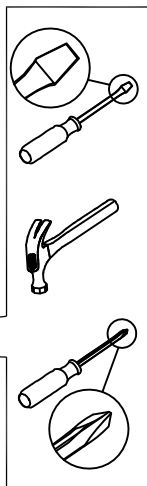

Call us at: **1-800-489-3351**  
(in U.S.A. only)  
Llamar a: (Solo en U.S.A)

Monday - Friday 7:00 am - 8:00 pm Central Time	Saturday 9:00 am - 5:00 pm Central Time
--	---



Fax: **1-636-745-1005**

Lunes - Viernes 7:00h - 20:00h Tiempo Central	Sabado 9:00h - 17:00h Tiempo Central
---	--

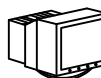

Visit our Website:  
Visite nuestro website: [www.altrafurniture.com](http://www.altrafurniture.com)



Write to: ALTRA FURNITURE  
Escribir a: 410 East 1st Street South Wright City, MO 63390 USA  
Attn: Service Dept.

### HELPFUL HINTS

- Visit our website for assembly video clips.
- Identify, sort and count the parts before attempting assembly.
- Call our toll free number if you need assistance identifying parts.
- Compression dowels are tapped in with a hammer.
- Slides have lips only on the right side.
- Cam locks that are properly fastened on a horizontal board will face toward the center of the unit, on a vertical board the point on the lock will face the bottom.
- Back panels provide stability and support. Use all the nails provided.
- When tapping nails into a board, be sure there are equal margins on all sides to square the unit.
- Units without the back panel installed may collapse.
- Clean the product with your favorite furniture polish and a soft cloth. DO NOT USE harsh chemicals or abrasive cleaners.
- Move your new furniture carefully, with two people lift and carry the unit to its new location.
- Never push, drag or scoot your furniture (especially on carpet).
- Your ALTRAFURNITURE can be disassembled and reassembled to move.
- Additional parts are available for a nominal fee.

### CONSEJOS ÚTILES

- Visite nuestro website para mirar los videos de montaje.
- Identificar, clasificar y contar las piezas antes de intentar el montaje.
- Llame gratis a nuestro número de servicio si necesita ayuda.
- Las clavijas de compresión se taladran con un martillo.
- Las correderas sólo tienen las protrusiones en el lado derecho.
- Las cerraduras de leva que se atan propiamente en una tabla horizontal se puntan al centro de la unidad, y las en una tabla vertical se puntan al fondo.
- Los paneles traseros son los que mantienen la estabilidad. Use todas las uñas proporcionadas.
- Cuando taladre la uña en la tabla, asegurarse que hay márgenes iguales en todos los lados para centrar la unidad.
- Las unidades sin panel trasero pueden derrumbarse.
- Limpiar la unidad con su pulimento favorito de mueble y una tela suave. NO UTILIZAR productos con químicos duros o abrasivos.
- Mueva su mueble nuevo cuidadosamente, lo ideal son dos personas para levantar la unidad a su nuevo lugar.
- Nunca empuje o arrastre su mueble (especialmente sobre alfombras).
- Su mueble ALTRAFURNITURE puede desmontarse y volverse a montar para moverlo de sitio.
- Las piezas adicionales están disponibles bajo pedido con costo adicional.

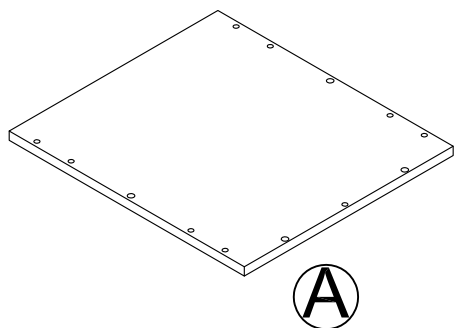

TOP  
Panel superior  
T9531096010

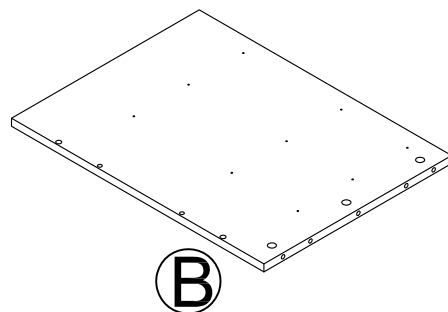

LEFT SIDE PANEL  
Panel lateral izquierdo  
T9531096020

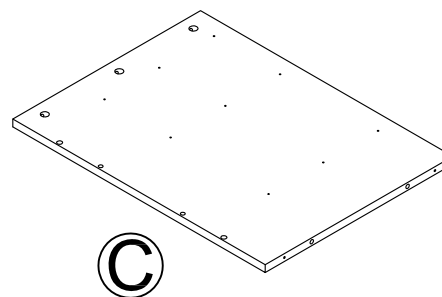

RIGHT SIDE PANEL  
Panel lateral derecho  
T9531096030

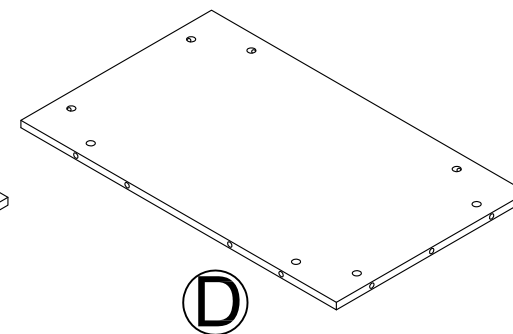

BACK PANEL  
Panel trasero  
T9531096040

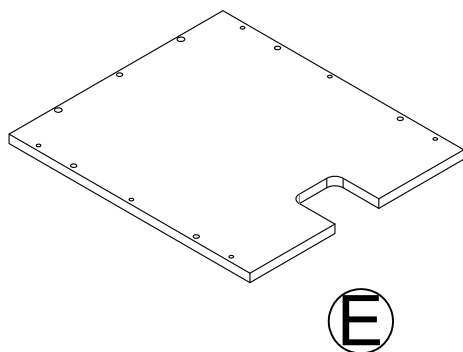

BOTTOM PANEL  
Panel base  
T9531096050

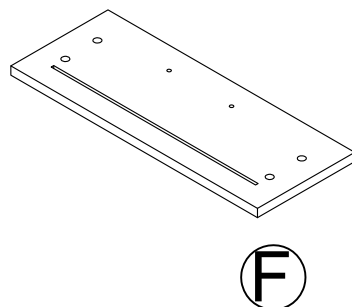

DRAWER FRONT  
Frente del cajón  
T9531096060  
QTY: 2

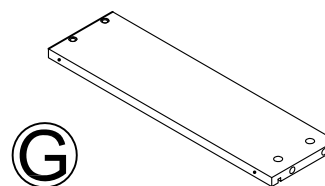

LEFT DRAWER SIDE  
Lado izquierdo del cajón  
T9531096070  
QTY: 2

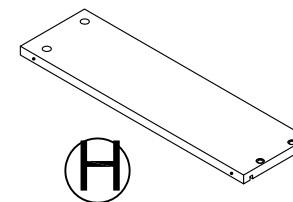

RIGHT DRAWER SIDE  
Lado derecho del cajón  
T9531096080  
QTY: 2

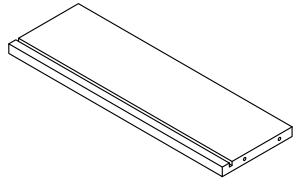

I

DRAWER BACK  
Panel trasero del cajón  
T9531096090  
QTY: 2

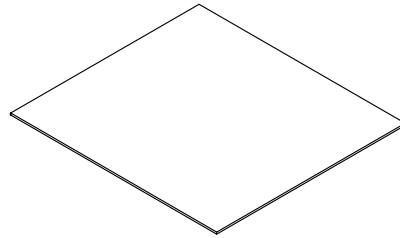

J

DRAWER BOTTOM  
Fondo del cajón  
T9531096100  
QTY: 3

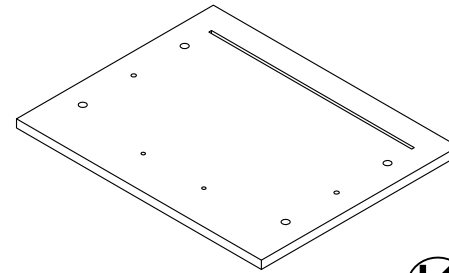

K

DRAWER FRONT  
Frente del cajón  
T9531096110

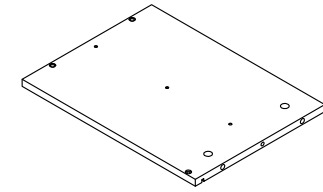

L

LEFT DRAWER SIDE  
Lado izquierdo del cajón  
T9531096120

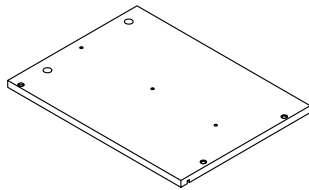

M

RIGHT DRAWER SIDE  
Lado derecho del cajón  
T9531096130

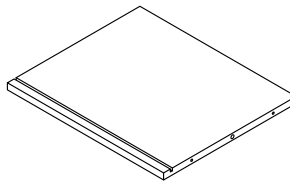

N

DRAWER BACK  
Panel trasero del cajón  
T9531096140

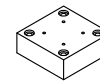

O

SUPPORT  
Soporte  
T9531096150

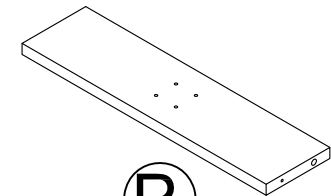

P

DRAWER SUPPORT  
Soporte de cajón  
T9531096160

**PARTS -PIEZAS**

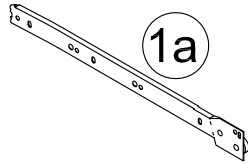
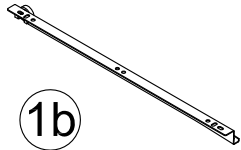
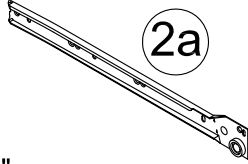
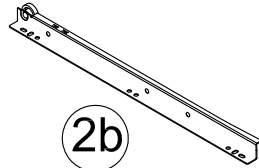
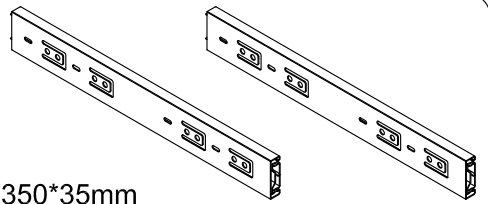
left cabinet member corredera de mueble izquierda  1a	left drawer runner deslizador izquierdo de cajon  1b	right cabinet member corredera de mueble derecha  2a 14"	right drawer runner deslizador derecha de cajon  2b	 350*35mm
1	x2	2	x 2	3
				x 1set

METAL SLIDE  
Riel de metal  
TDK1029

METAL SLIDE  
Riel de metal  
TDK1016

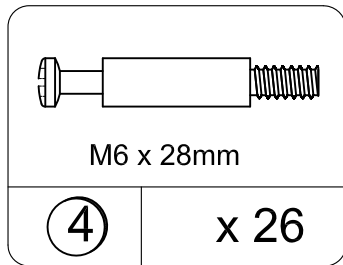

CAM BOLT  
Tornillo de rosca  
TDK0001

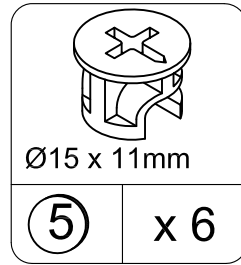

CAM LOCK  
Tornillo de cerradura  
TDK0002

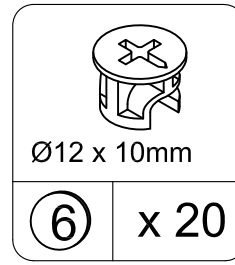

CAM LOCK  
Tornillo de cerradura  
TDK0012

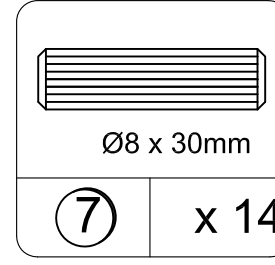

WOOD DOWEL  
Clavija de madera  
TDK0201

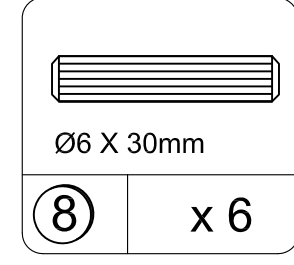

WOOD DOWEL  
Clavija de madera  
TDK0204

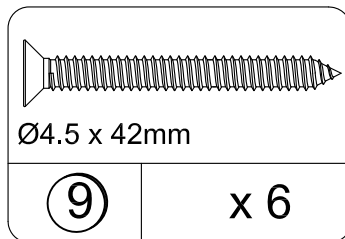

SCREW  
Tornillo  
TDK0007

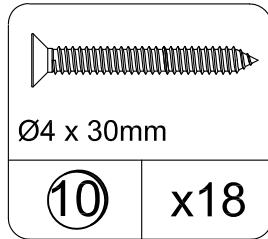

SCREW  
Tornillo  
TDK0010

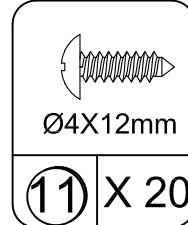

SCREW  
Tornillo  
TDK0107

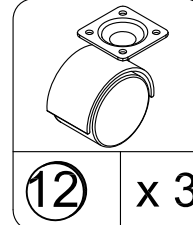

CASTER  
echador  
TDK3003

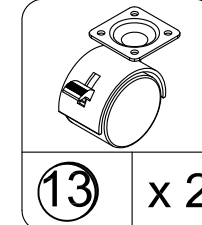

CASTER WITH LOCK  
lanzador con cerradura  
TDK3002

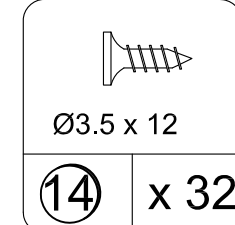

Screw  
Tornillo  
TDK0009

## PARTS -PIEZAS

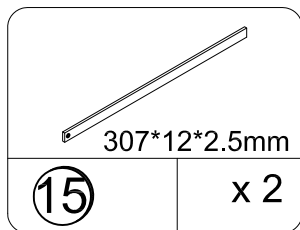

METAL FILE HOLDER  
Soporte de fichero de mrtales  
TDK3007

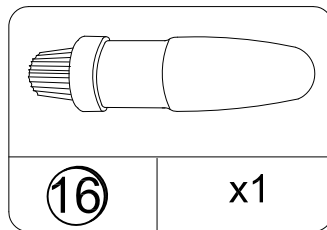

GLUE  
La cola  
TDK2000

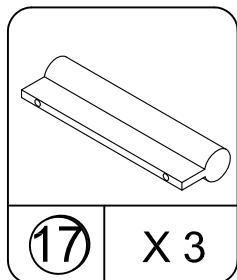

HANDLE  
Tirador  
TDK1030

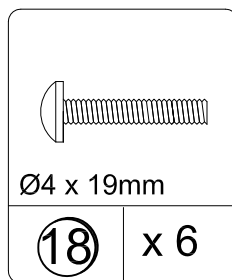

BOLT  
Perno  
TDK0115

This illustration shows how the CAM fastening system works.

Esta ilustración muestra como funciona el sistema de fijación de leva.

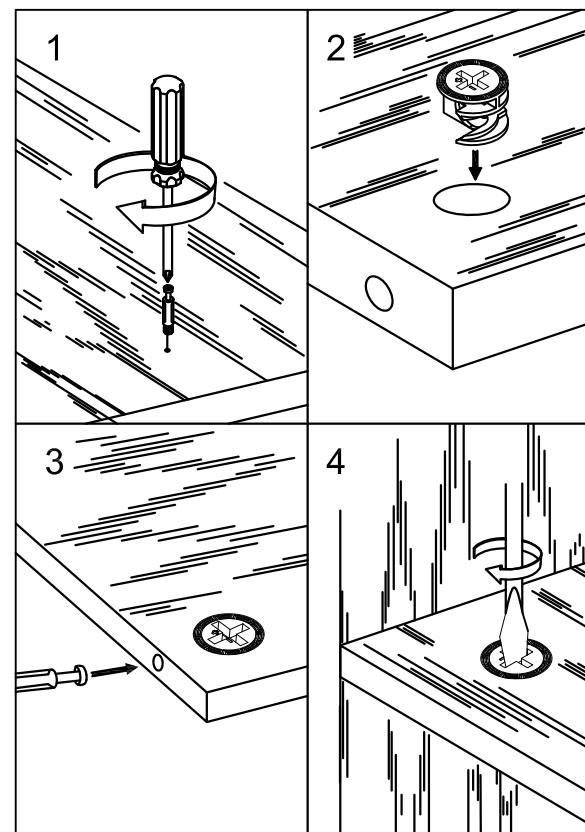

To view a video on how the CAM fastening system works, download a free QR-reader on your smartphone, then scan the code.

Para ver un video de como funciona el sistema de sujeción CAM, descargue una aplicación gratis que podra ver en su teléfono movil, entonces escnee el código.

# 1

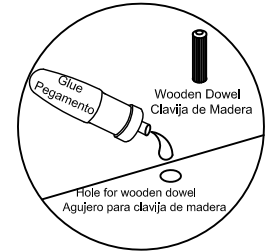
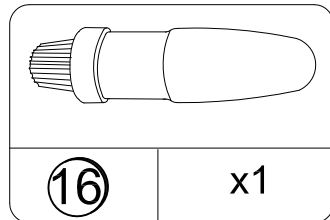
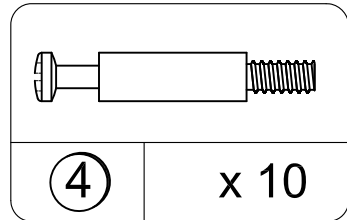
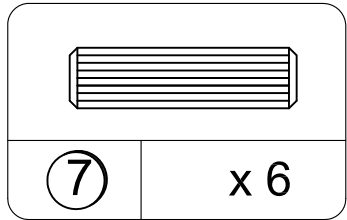
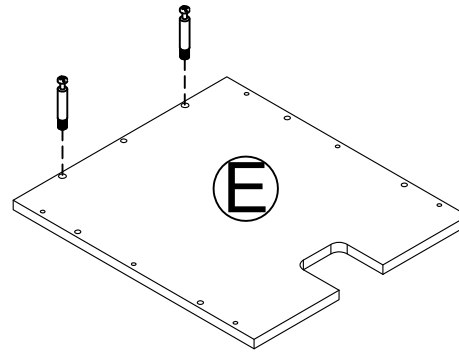
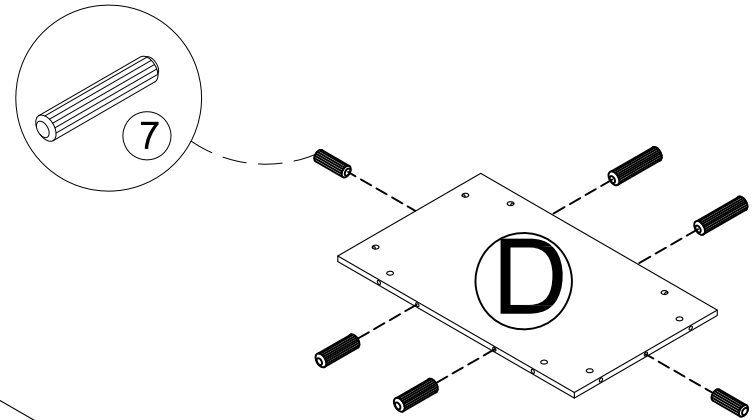
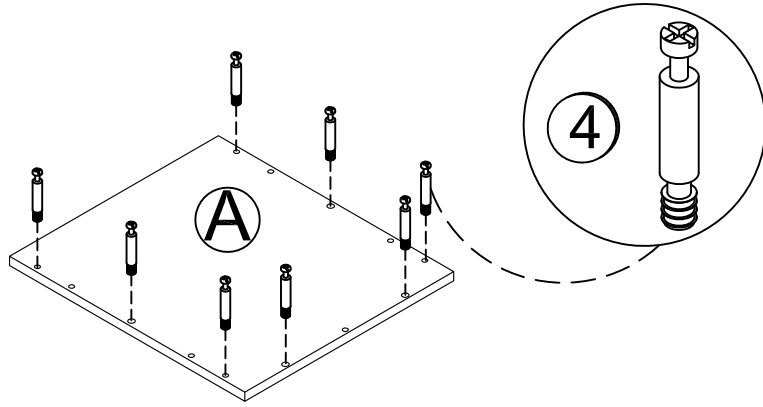

# 2

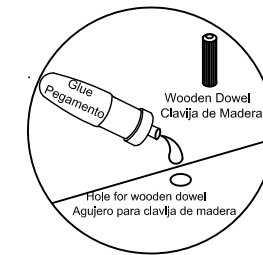
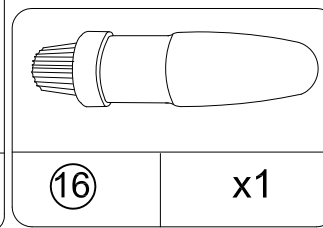
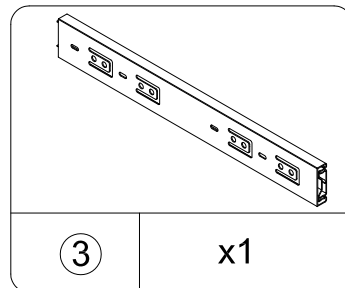
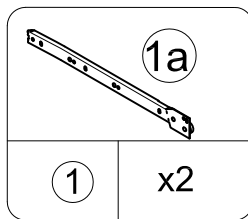
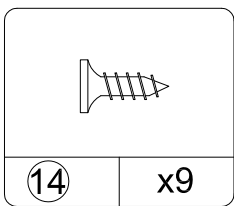
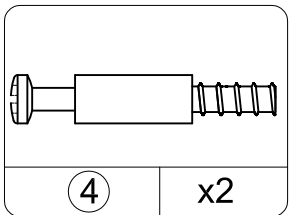
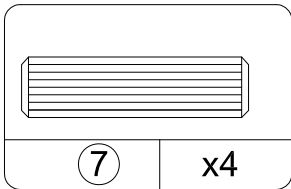
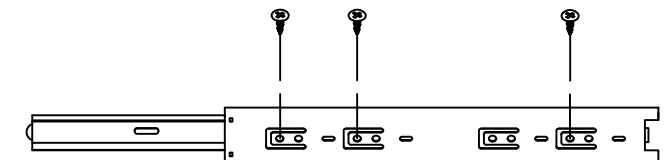
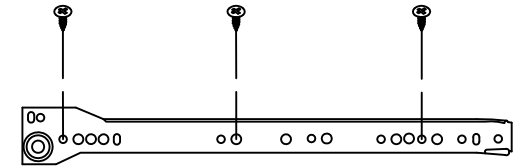
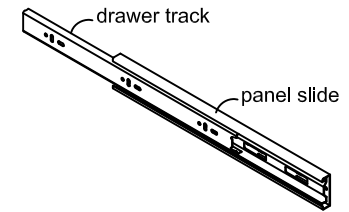
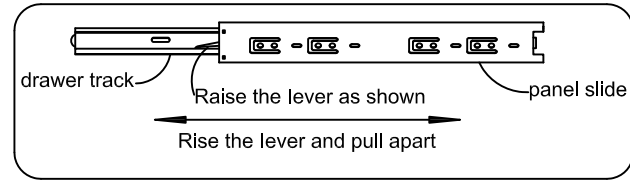
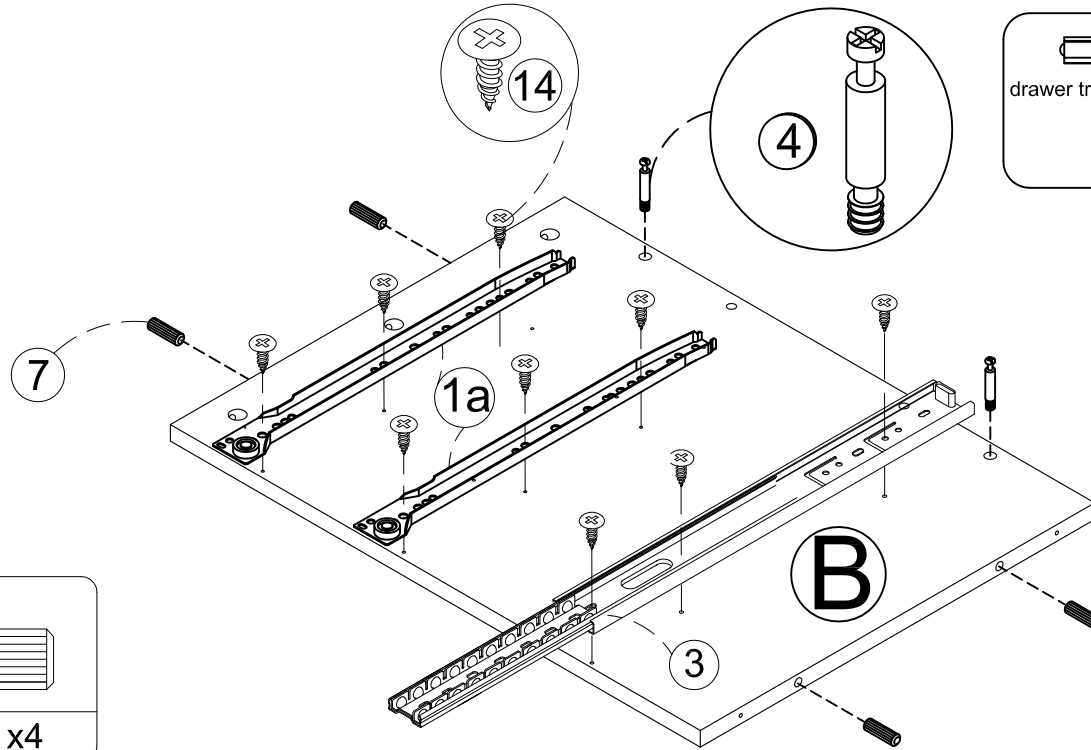



# 3

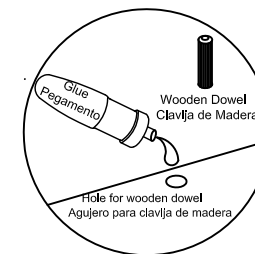
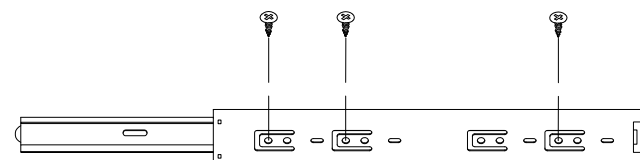
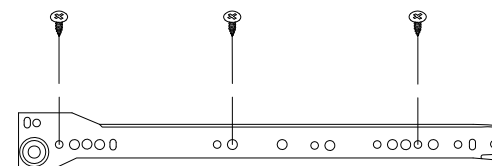
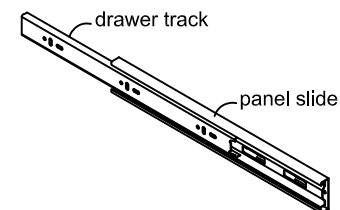
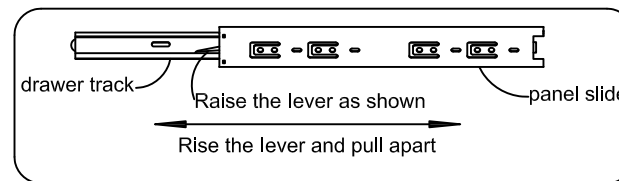
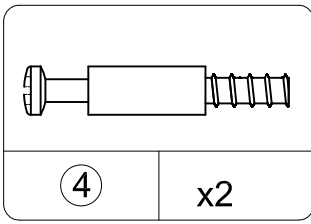
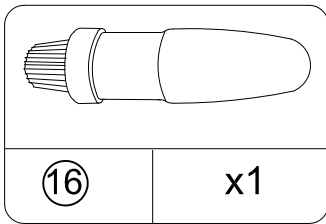
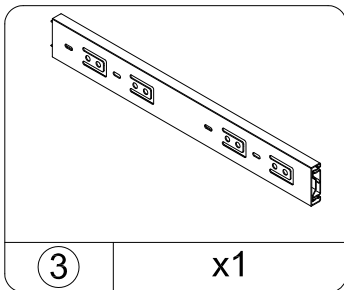
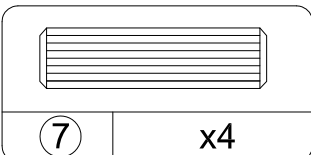
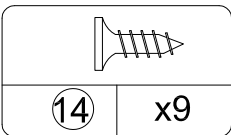
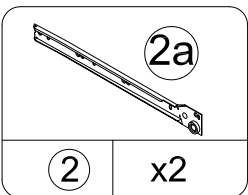
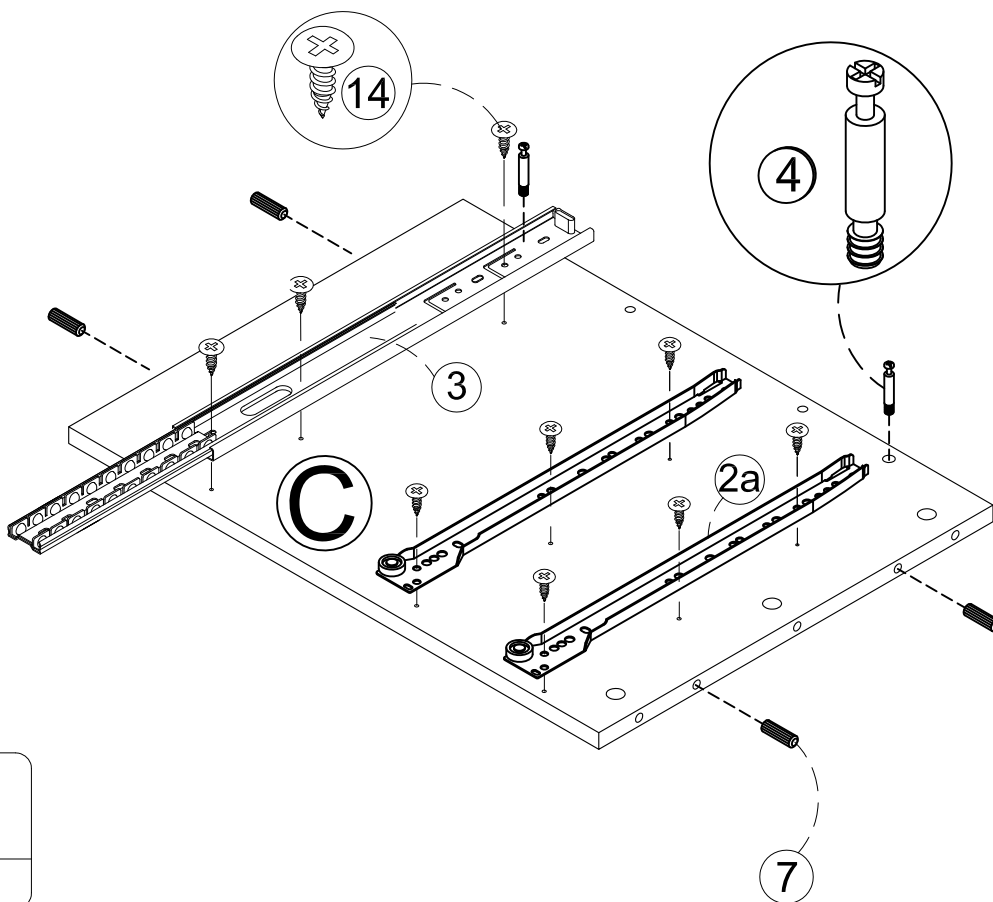

# 4

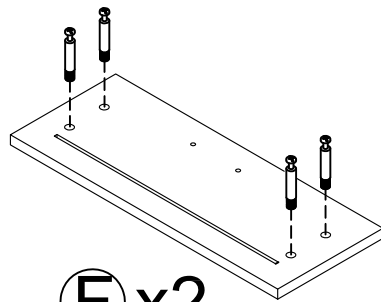

F x2

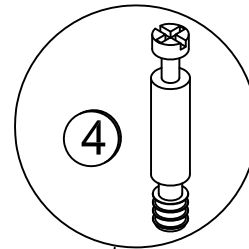

4

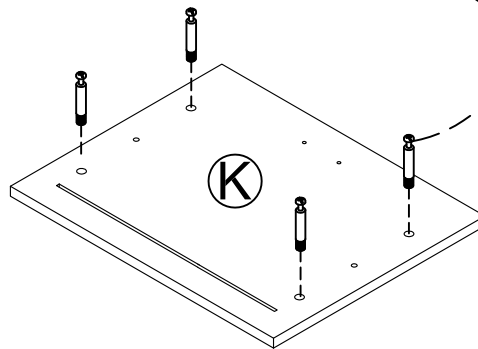

K

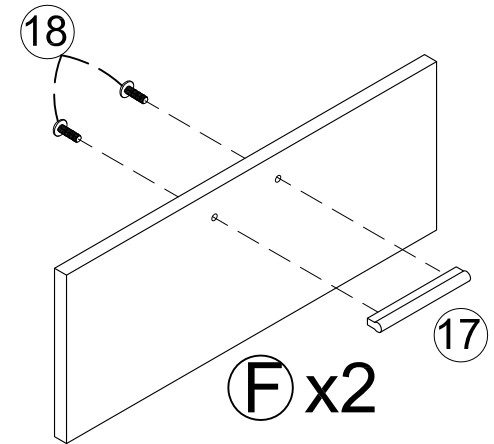

F x2

17

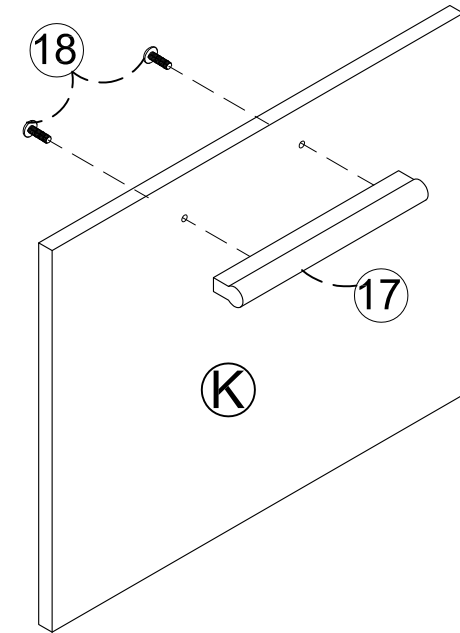

K

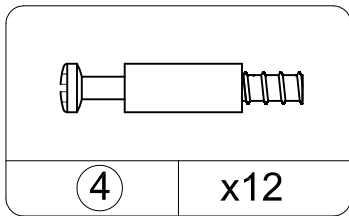

4 x12

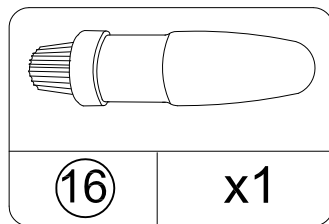

16 x1

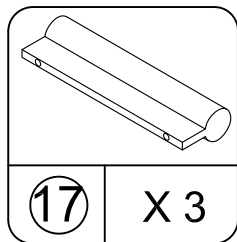

17 x3

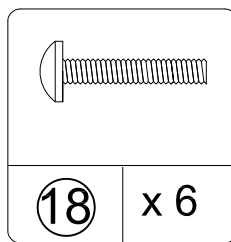

18 x6

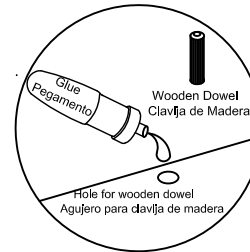

# 5

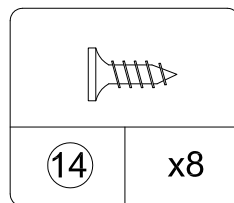
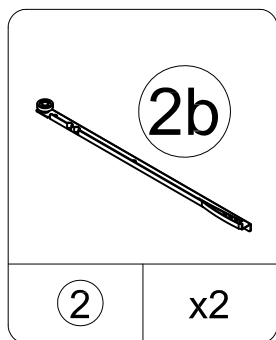
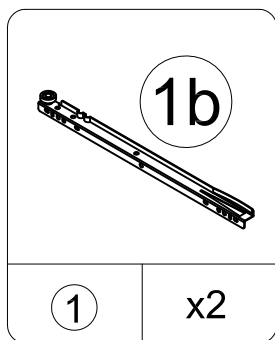
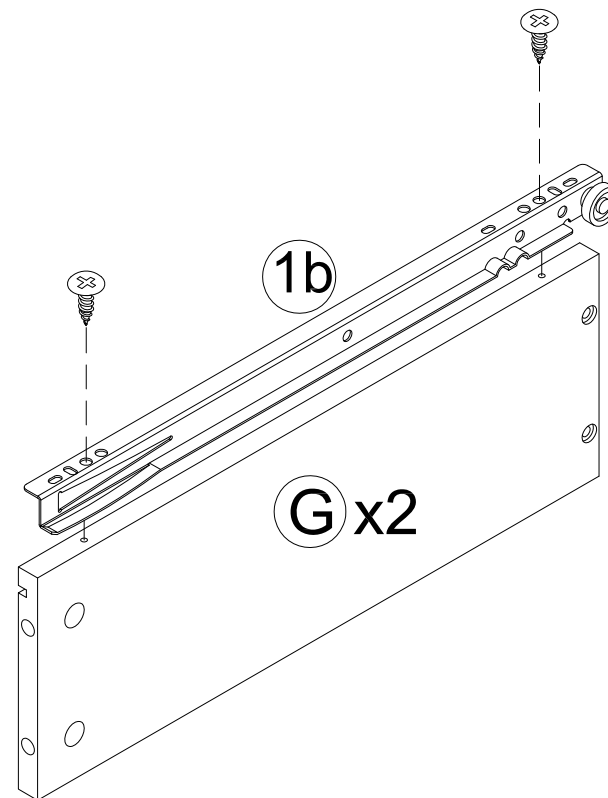
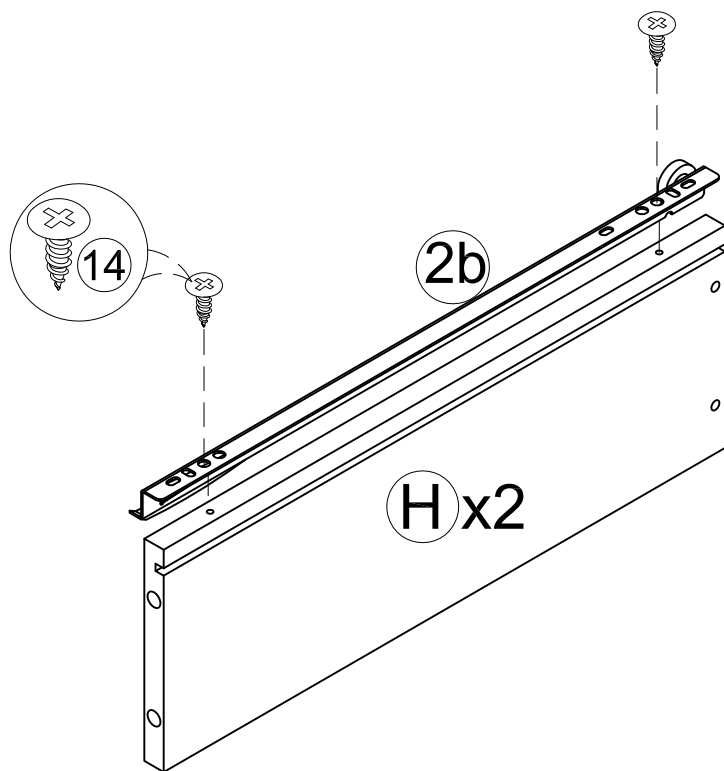

# 6

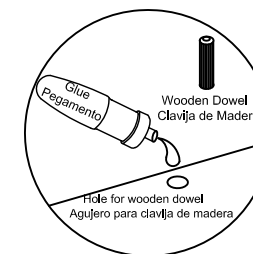
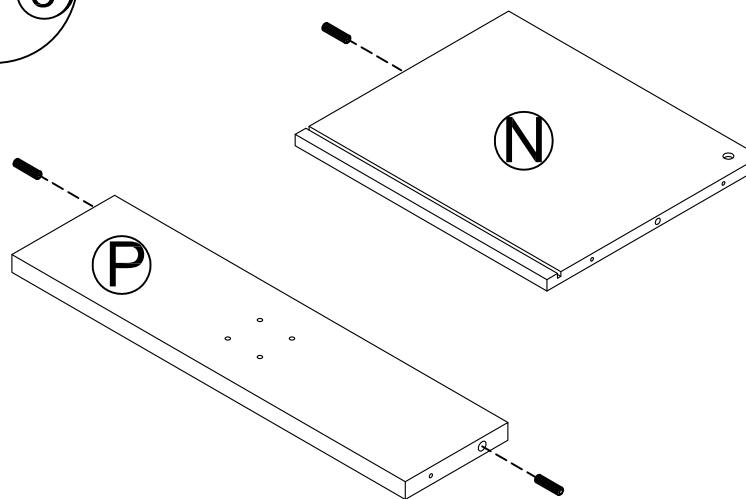
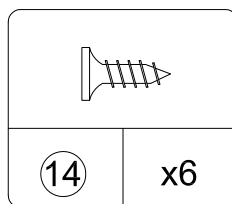
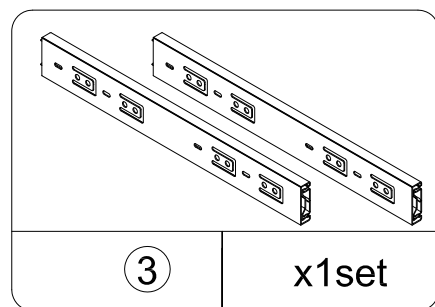
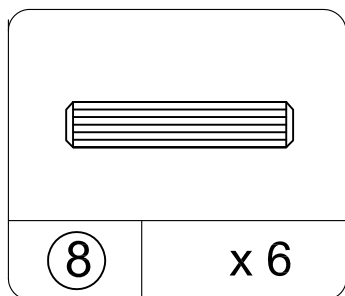
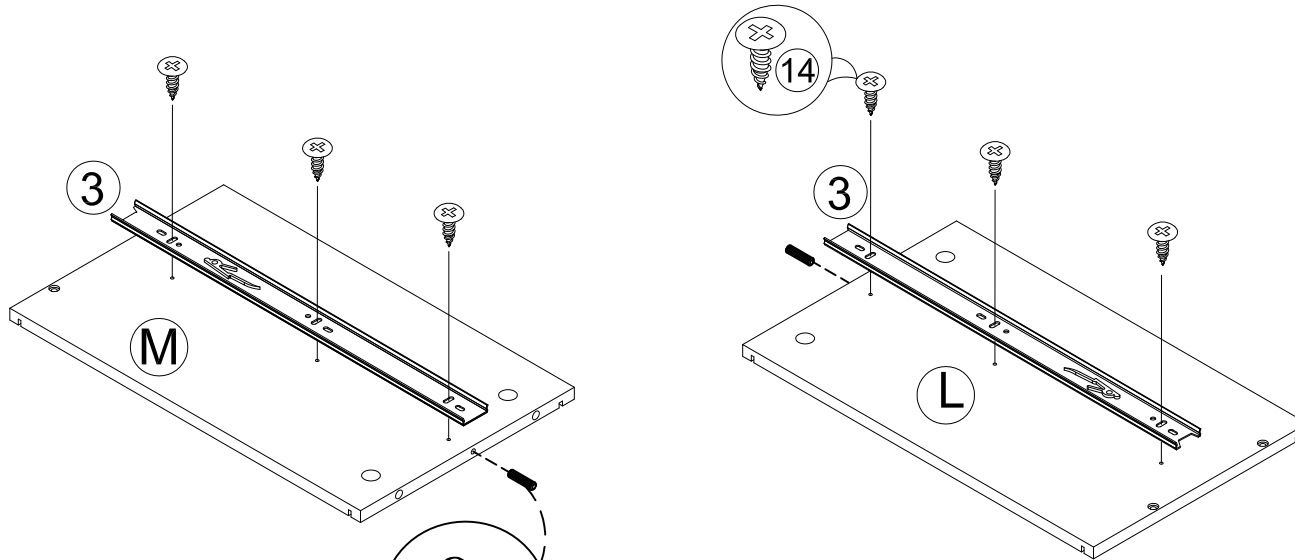

# 7

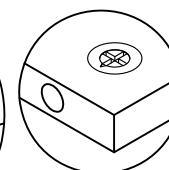
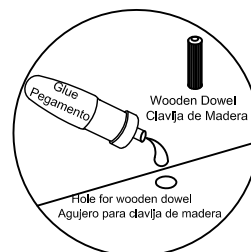
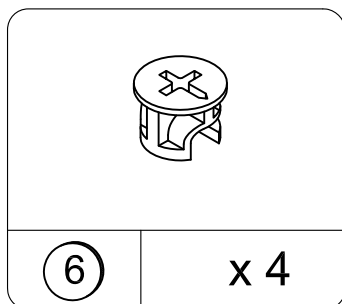
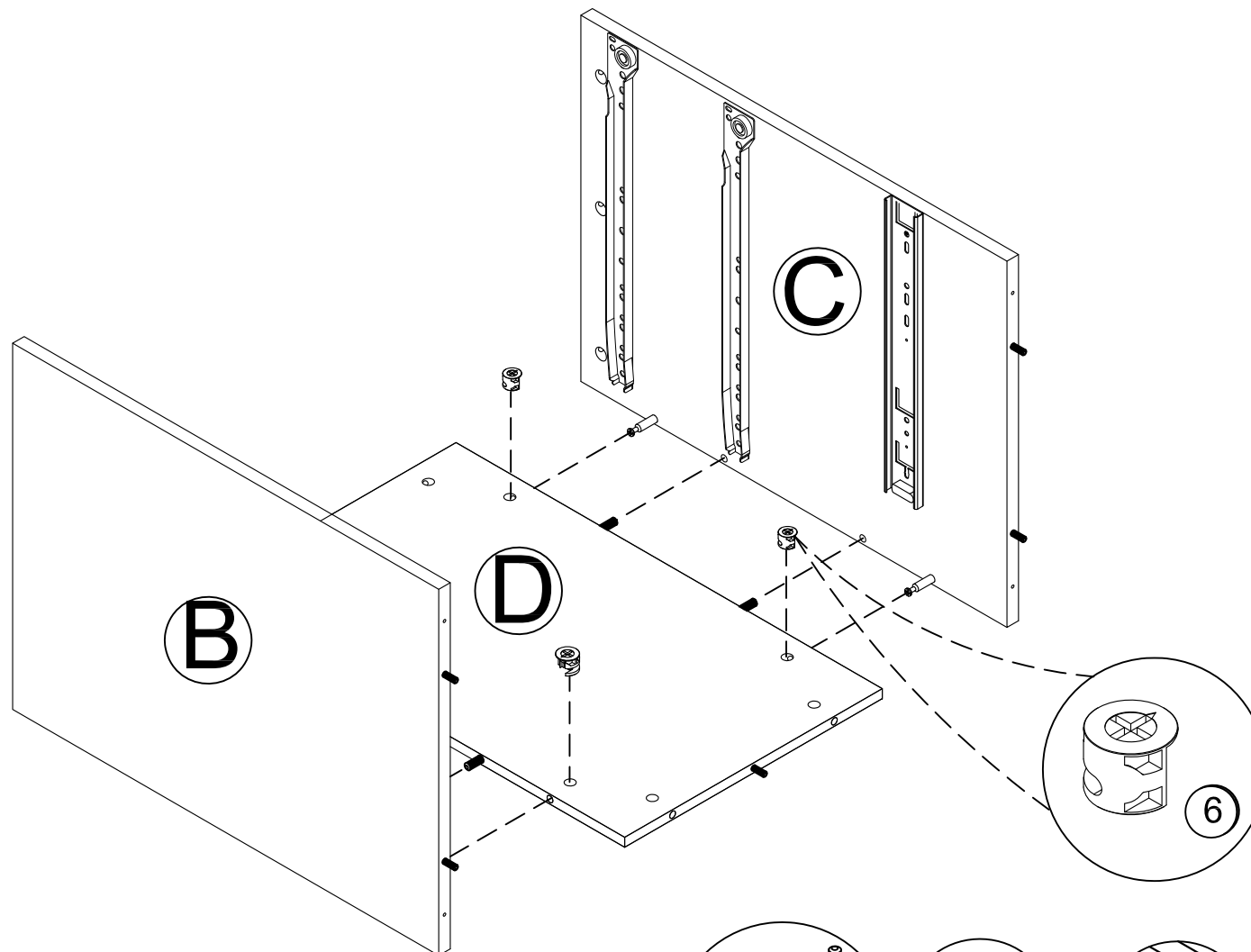

Proper orientation of cam lock  
La orientación apropiada para el seguro de bloqueo

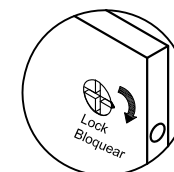

# 8

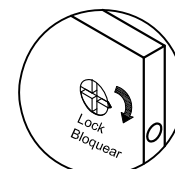
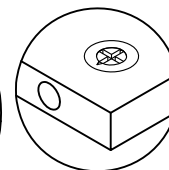
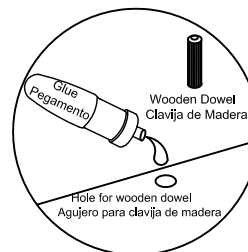
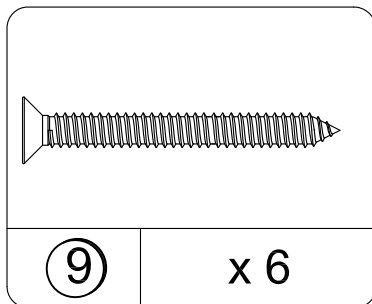
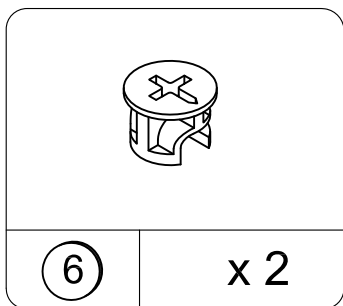
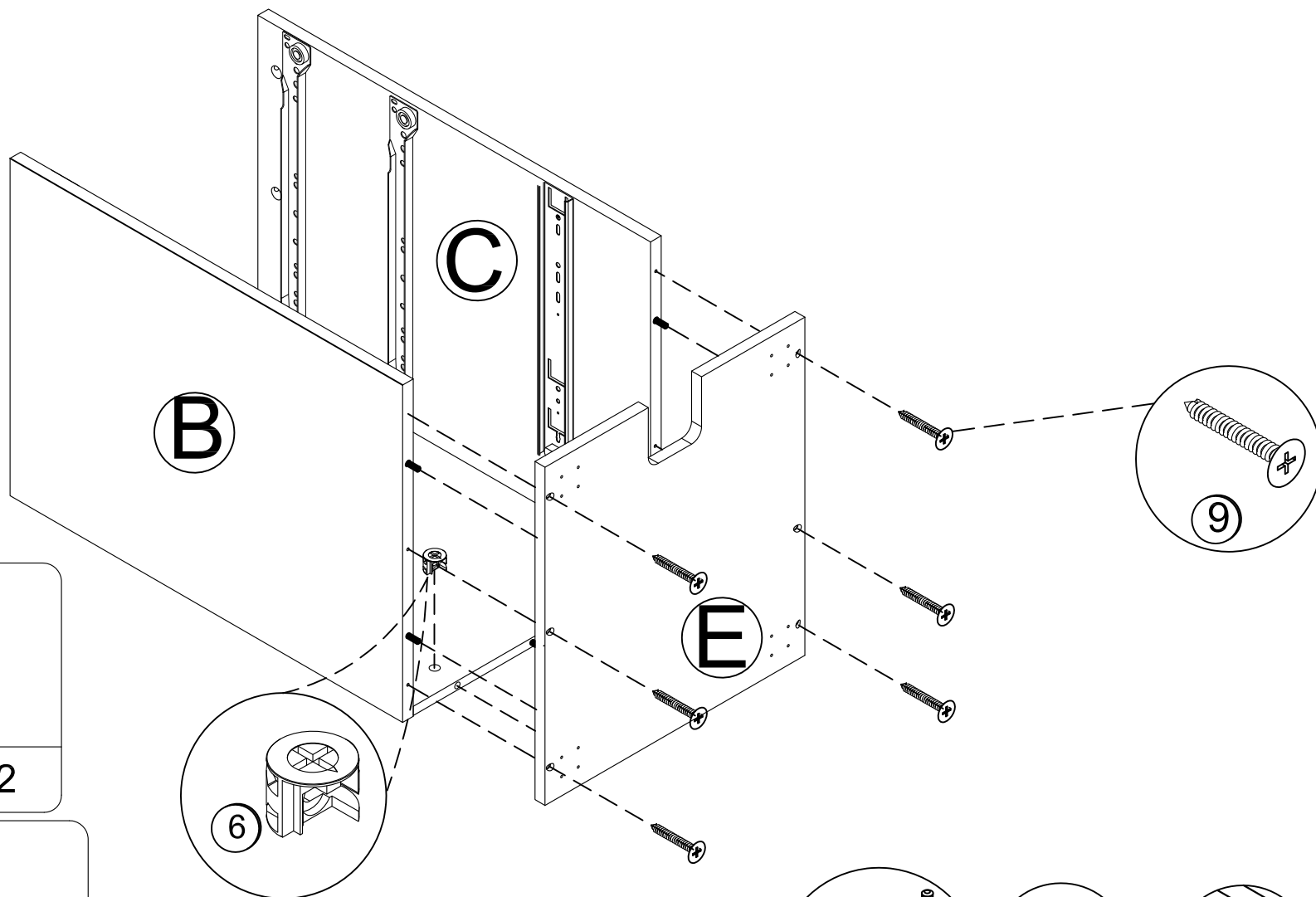

Proper orientation of cam lock  
La orientación apropiada para el seguro de bloqueo

# 9

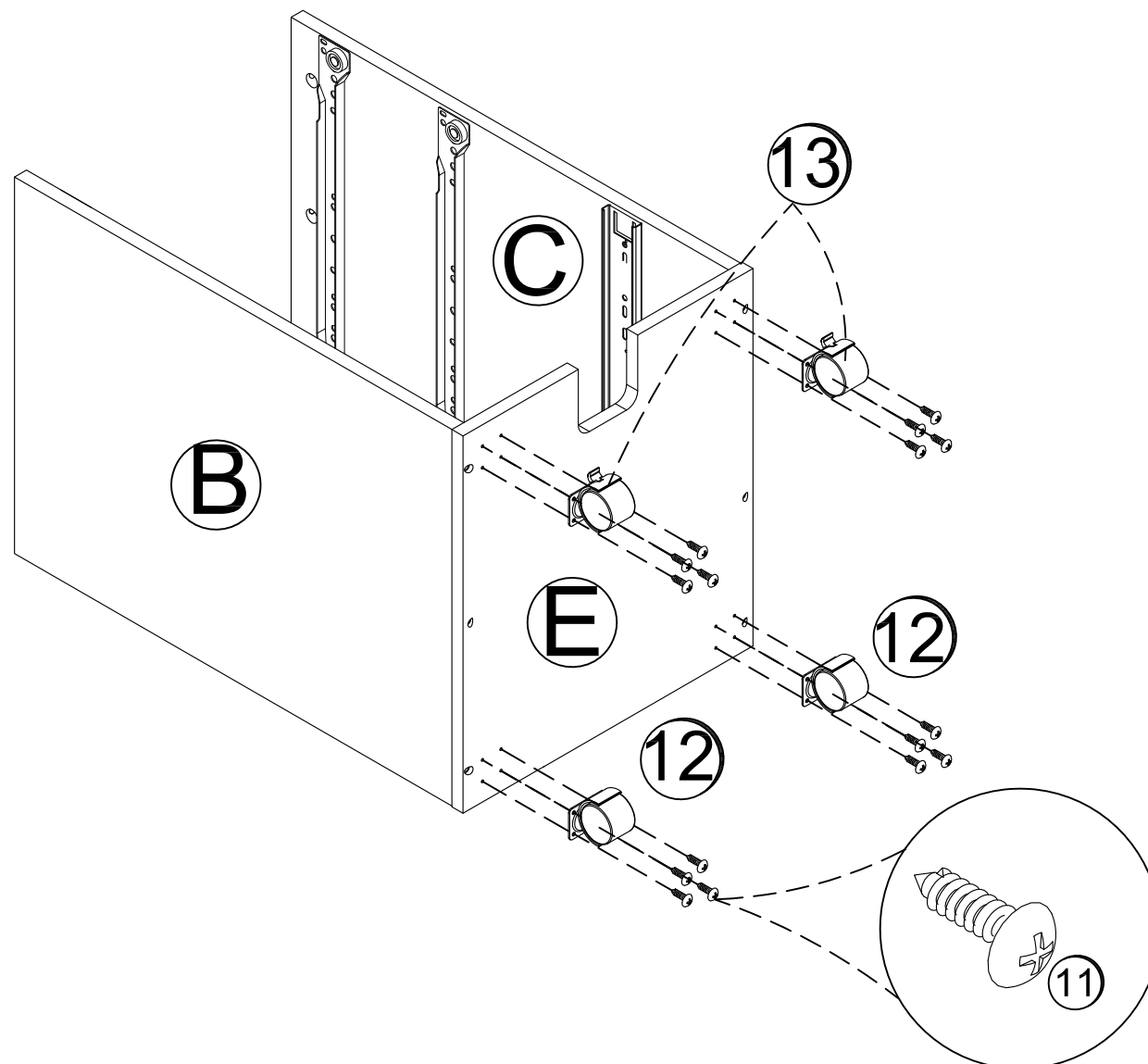
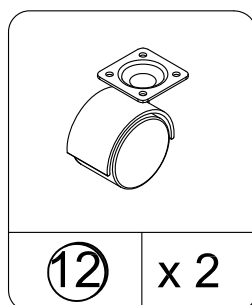
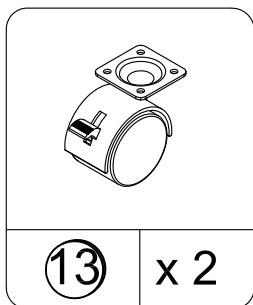
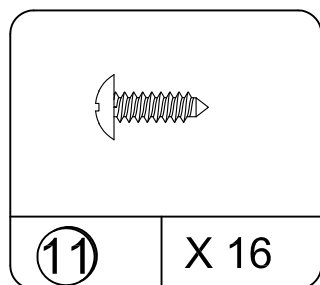

# 10

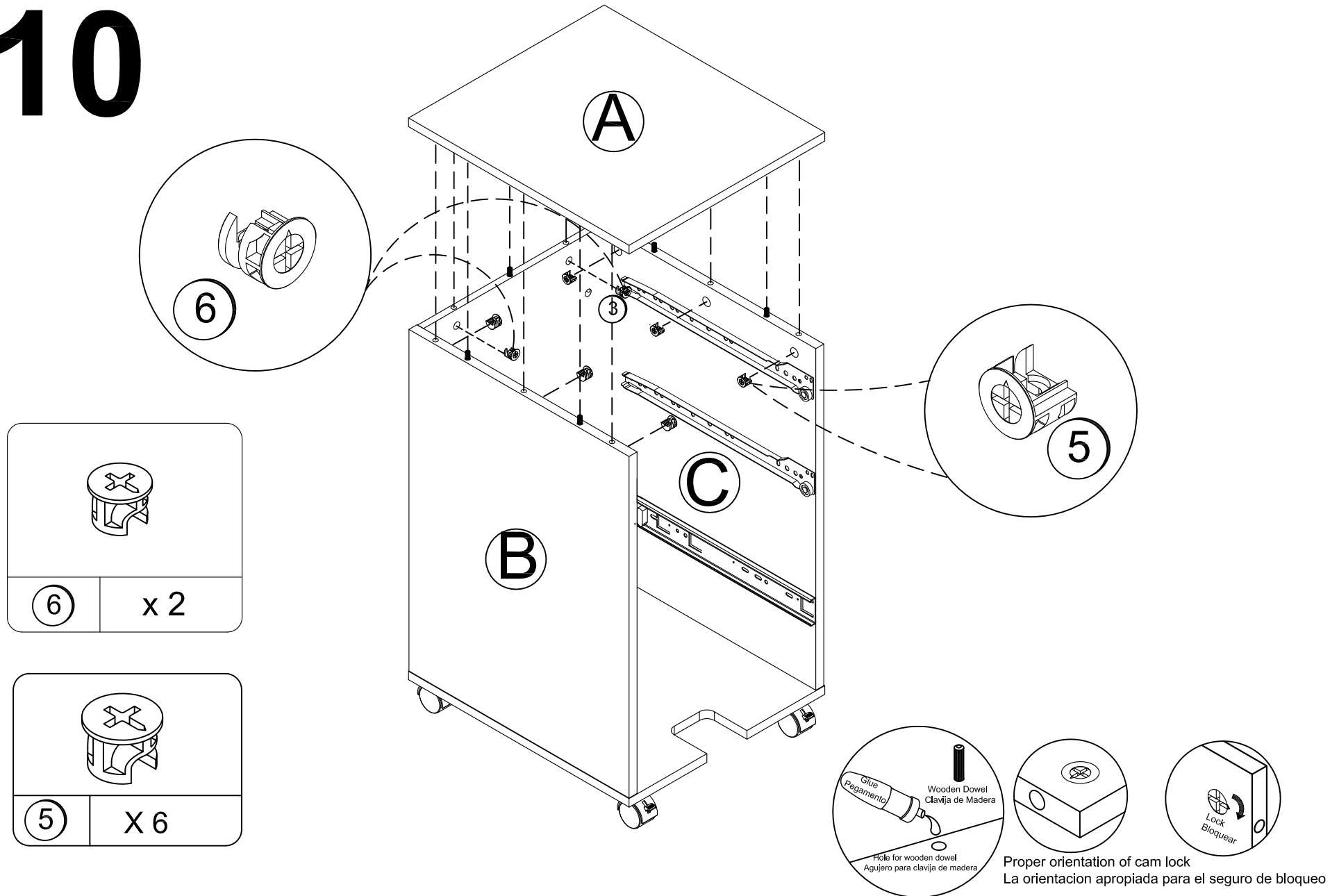



# 11 x 2

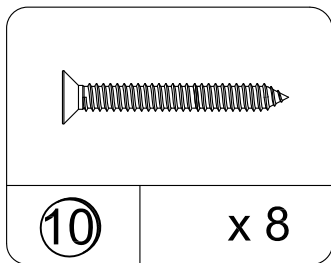
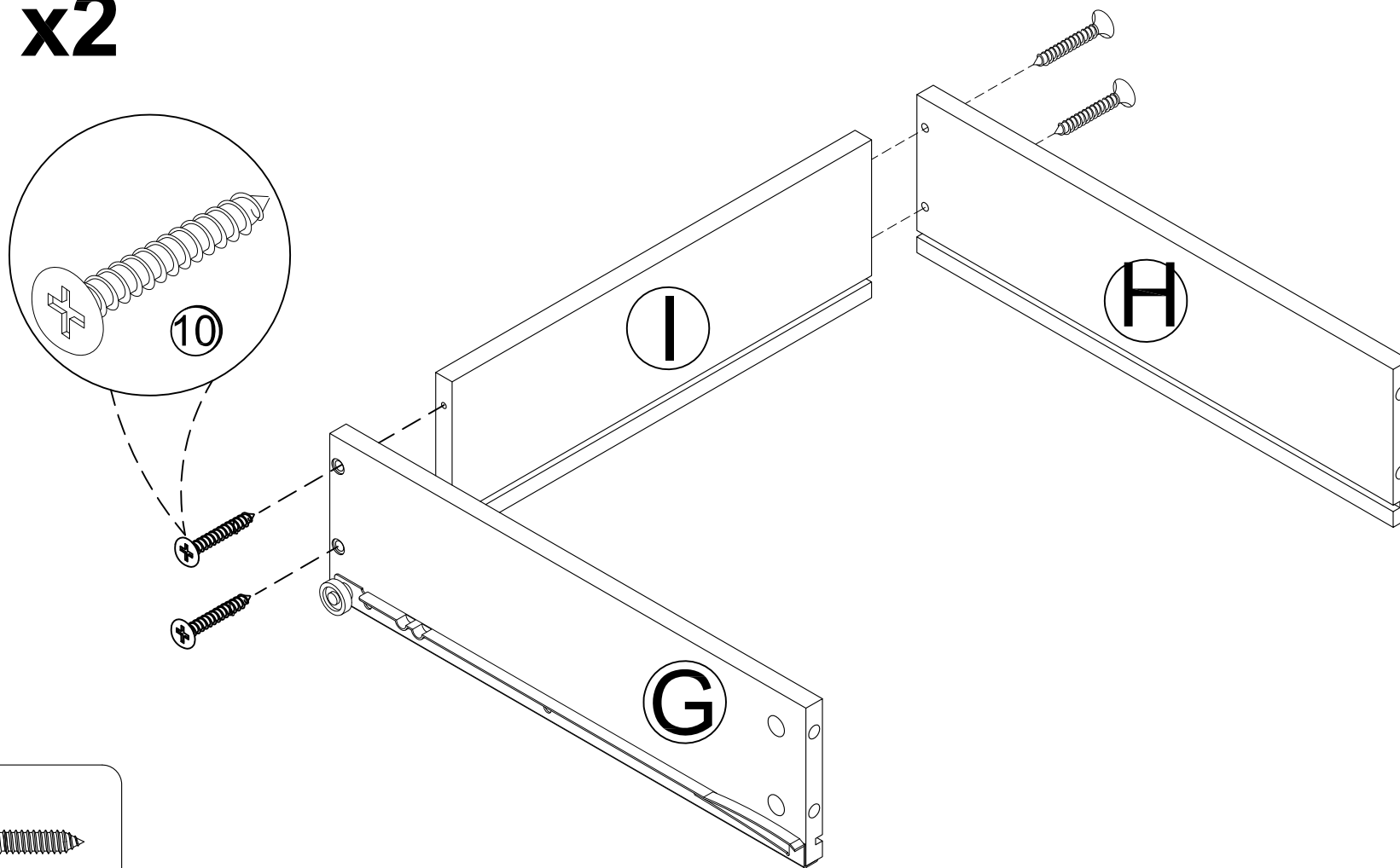

# 12x2

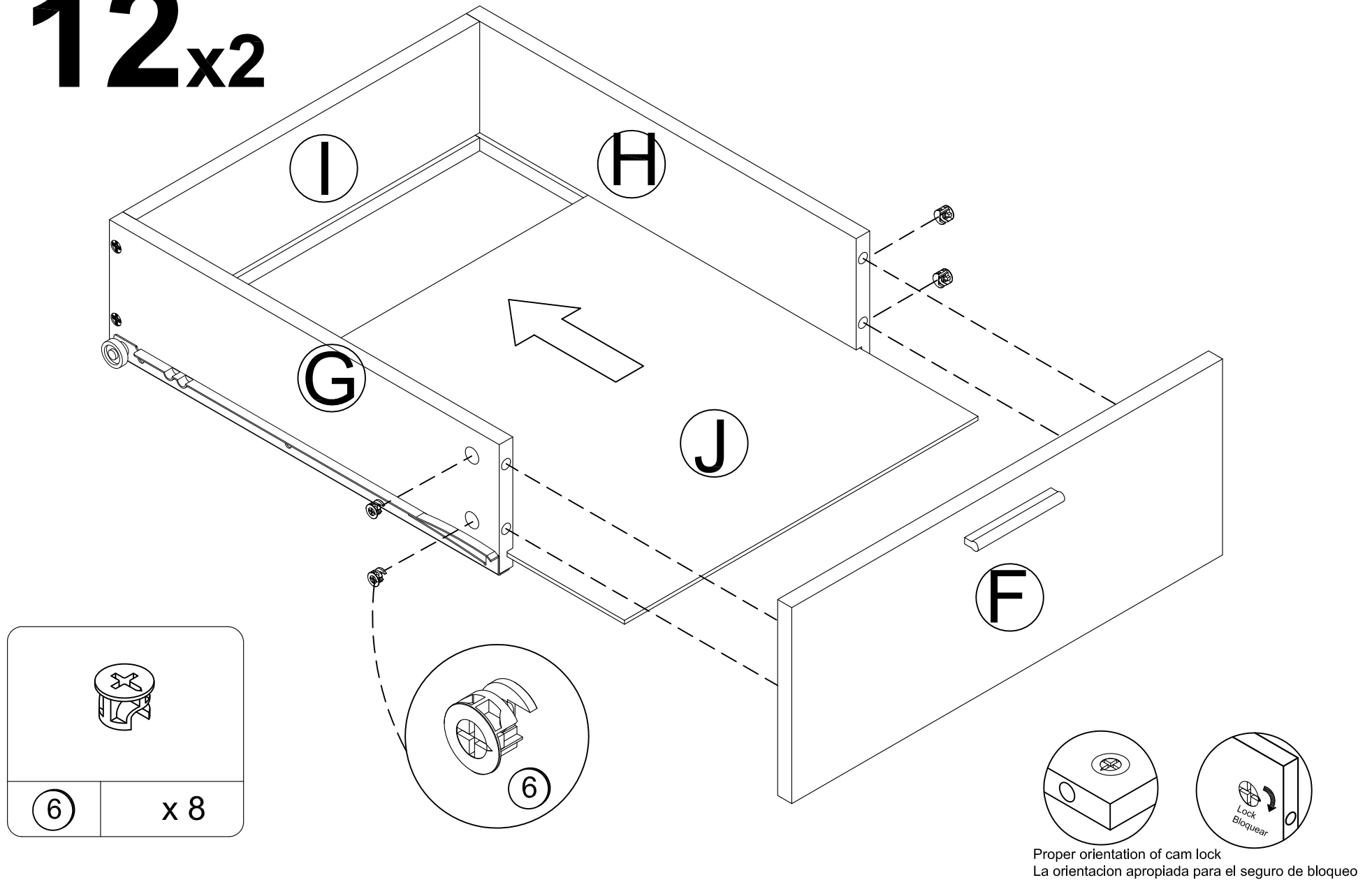

Proper orientation of cam lock  
La orientación apropiada para el seguro de bloqueo

# 13

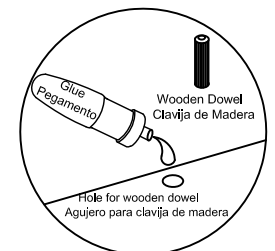
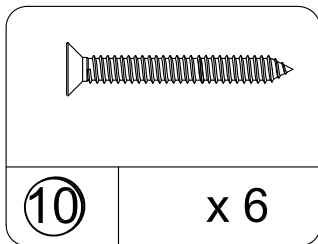
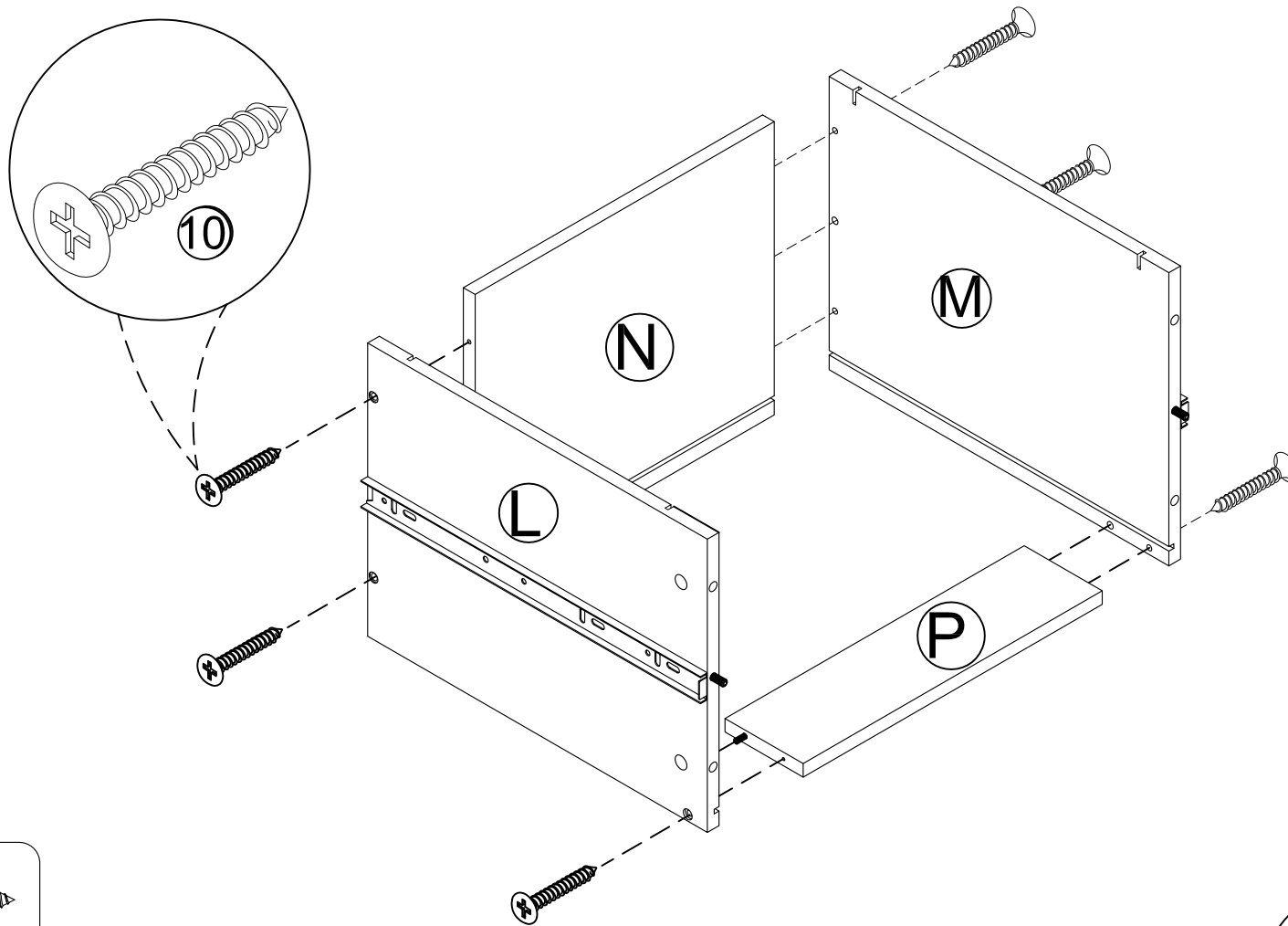

# 14

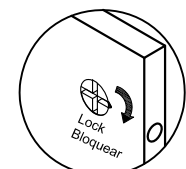
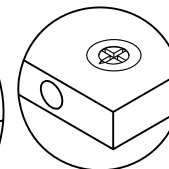
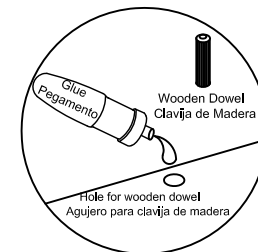
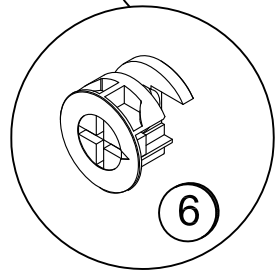
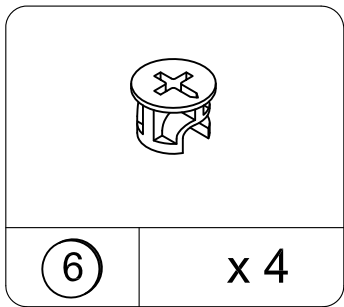
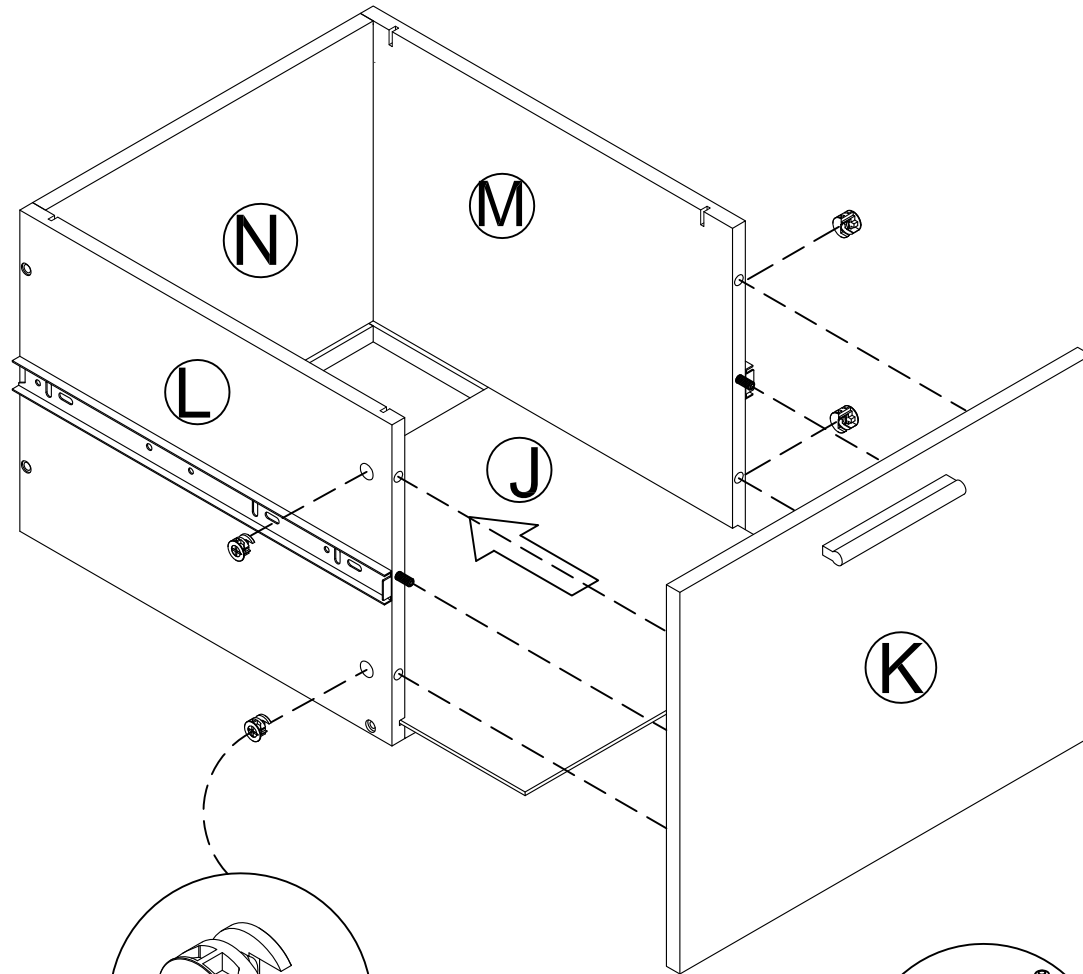

Proper orientation of cam lock  
La orientación apropiada para el seguro de bloqueo

# 15

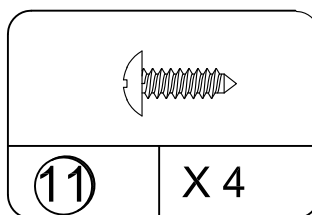
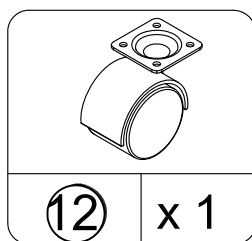
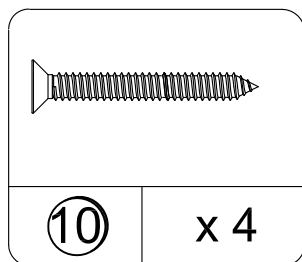
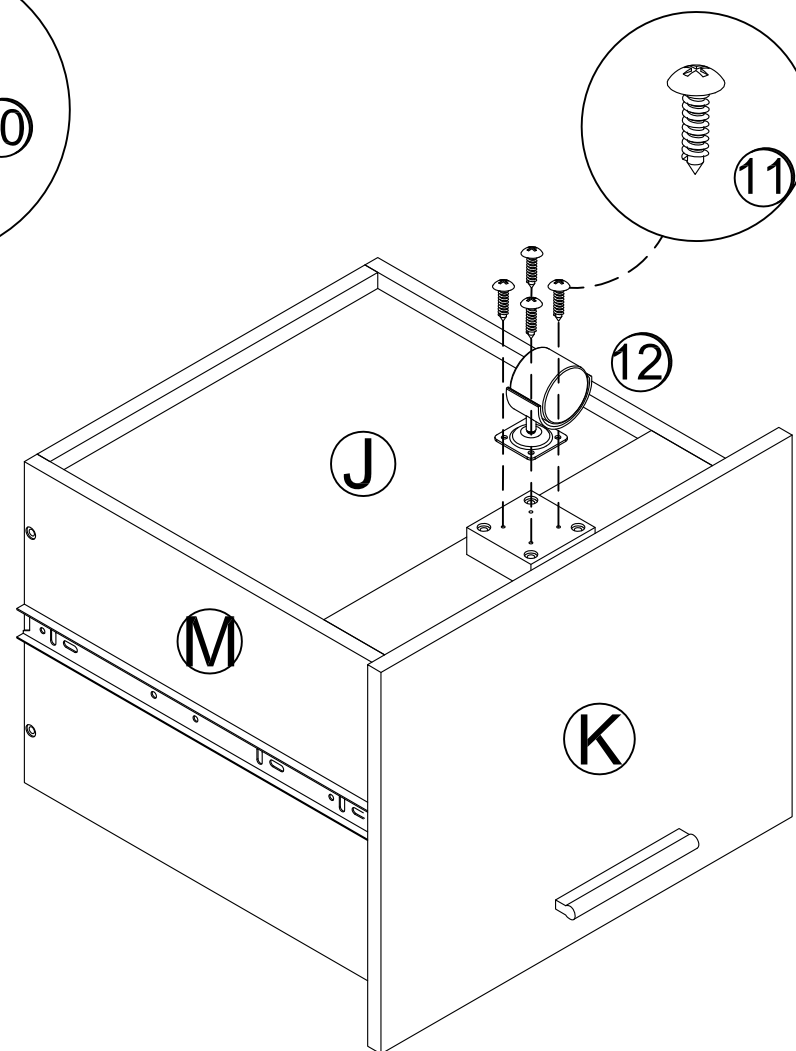
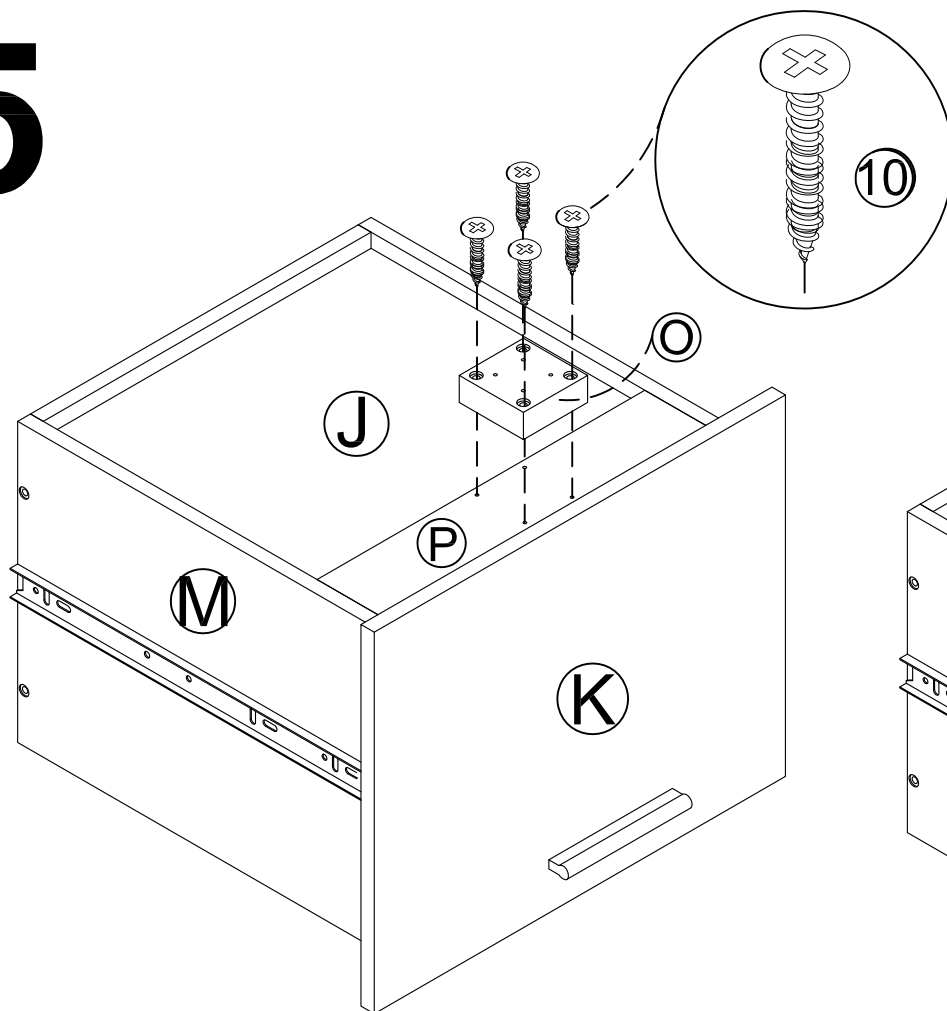

# 16

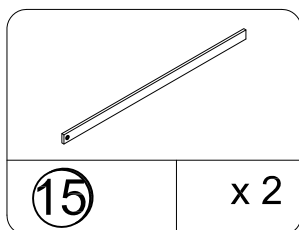
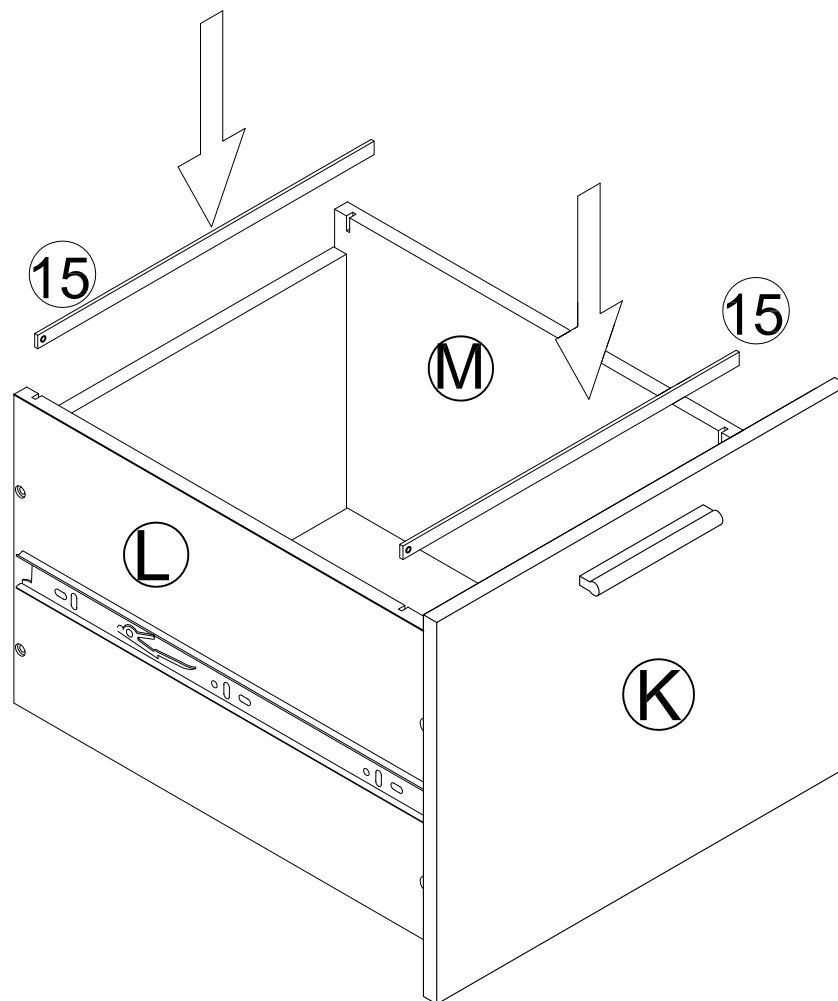

# 17

**NOTE: This step is just for insert or remove drawer if needed.**

## To Insert Drawer Into Cabinet

- Bottom drawer first.
- Bring ball bearing retainer fully forward, as shown.
- With help of another person, carefully align and insert drawer slide into cabinet slide, guiding the drawer slide between the ball bearing retainer, as shown.
- Push the drawer into cabinet. You may experience a light resistance when pushing the drawer into cabinet but once both slides are properly engaged, drawer should slide in and out smoothly.

NOTE: Do not use excessive force to insert drawer as this may cause the damage to slides.

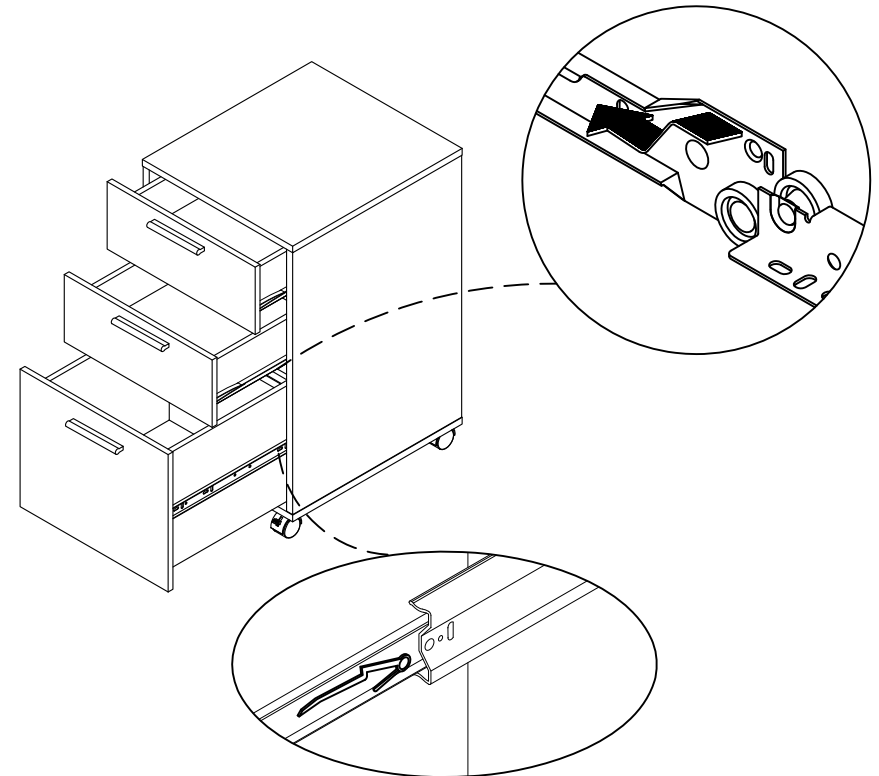
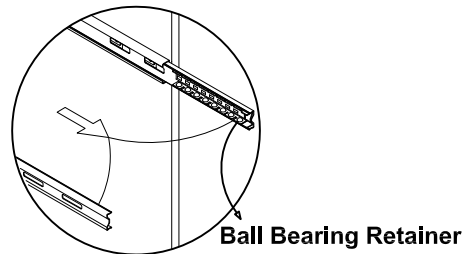

Repeat Above Step To Insert Upper Drawer.

## To Remove Drawer, If Needed

- Pull the drawer fully open so levers are visible.
- Push UP on left side lever and DOWN on right side lever.
- Holding levers in place, pull drawer toward you.

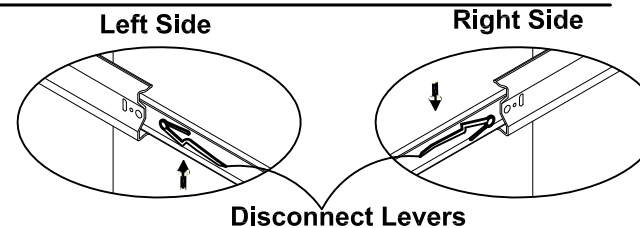

WEIGHT LIMITS:  
LÍMITES DE PESO:

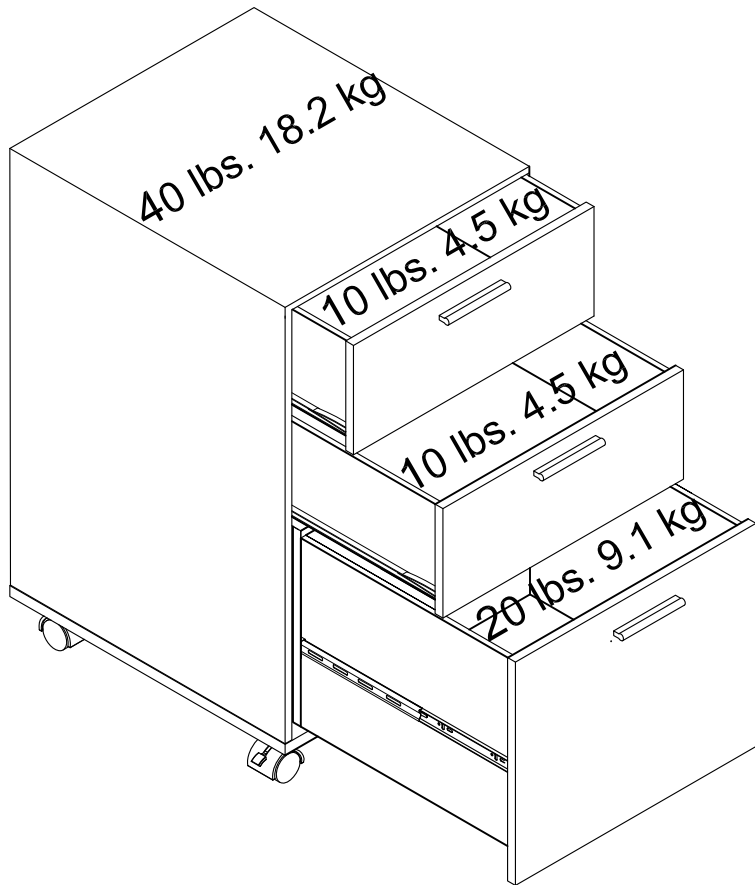

Enjoy Your Furniture  
DISFRUTE DE SU MUEBLE

This unit has been designed to support the maximum loads shown.

Exceeding these load limits could cause sagging, instability, product collapse, and/or serious injury.

Esta unidad se ha diseñado para apoyar las cargas máximas mostradas.

Exceder estos límites de carga podría causar ceder, inestabilidad, derrumbamiento del producto, y/o lesión seria.

**▲ WARNING**

Please make sure that all objects are removed before moving the assembled unit.

The unit must be team lifted, not dragged or pushed.

Failure to do so could cause instability, product collapse, and/or serious injury.

**▲ ADVERTENCIA**

Por favor mueva el mueble cuidadosamente con la ayuda de otra persona. Levante y mueva el mueble a su lugar.

No lo arrastre o empuje, de lo contrario puede haber inestabilidad en el mueble y este puede colapsar u ocasionar graves lesiones.