



SERVICE PARTS LIST

BULLETIN NO.
54-49-2810

SPECIFY CATALOG NO. AND SERIAL NO. WHEN ORDERING PARTS		REVISED BULLETIN	DATE
M18™ FUEL™ POWER UNIT			Feb. 2019
CATALOG NO.	2825-21	STARTING SERIAL NO.	K49A
		WIRING INSTRUCTION See Page 7	

Page 1 Power Unit Exploded View **Page 4 Hedge Trimmer Exploded View** **Page 7 Wiring Diagram**
Page 2 Edge Trimmer Exploded View **Page 5 Pole Saw Exploded View**
Page 3 String Trimmer Exploded View **Page 6 Extension Tube Assembly**

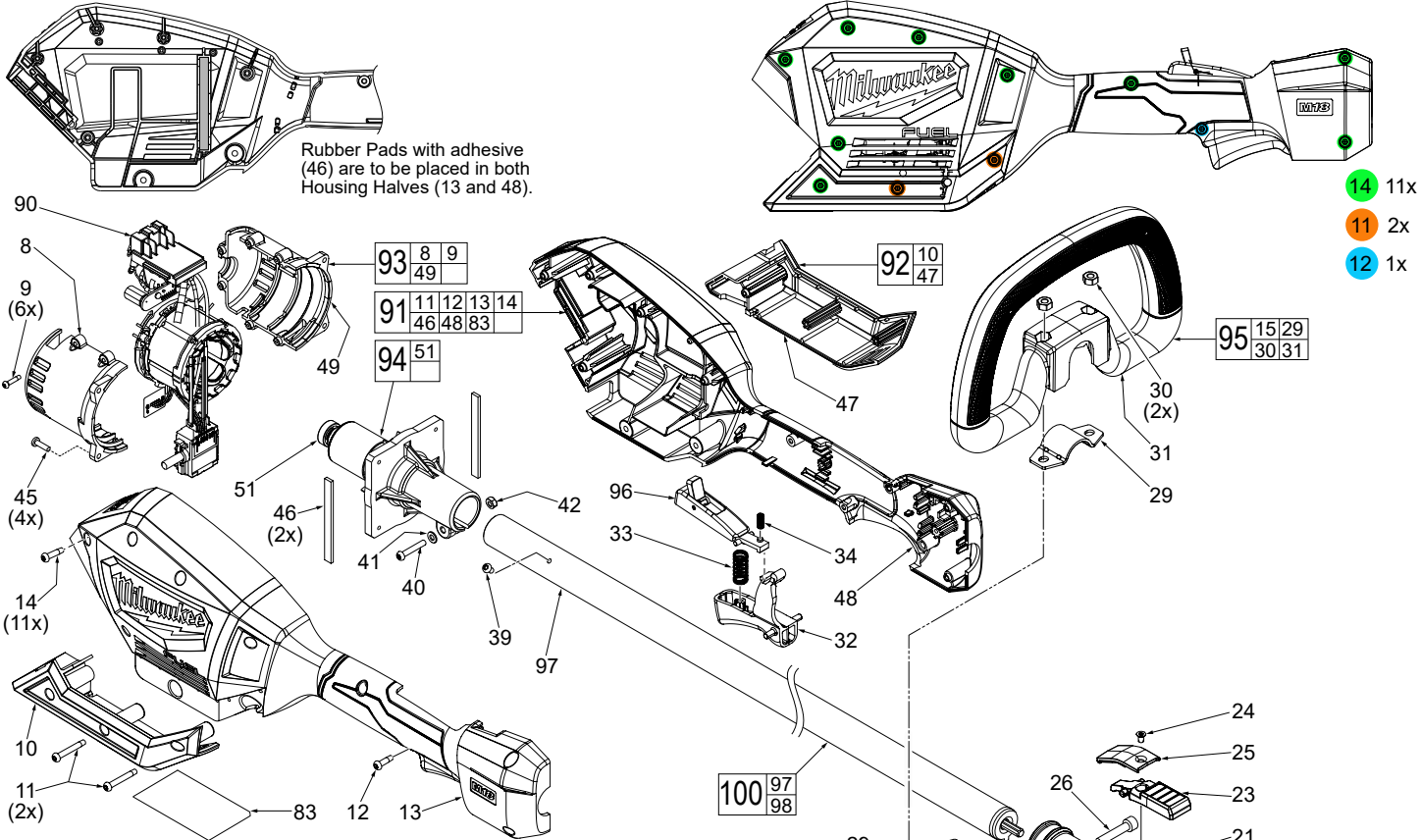

14 11x
11 2x
12 1x

FIG.	PART NO.	DESCRIPTION OF PART	NO. REQ.
8	-----	Motor Insulator - Right	(1)
9	06-82-0180	M3 x 14mm Pan Hd. ST T-10 Screw	(6)
10	-----	Lower Cover Halve - Right	(1)
11	05-88-1300	M4 x 28mm Pan Hd. ST T-20 Screw	(2)
12	05-88-5375	, x 13.5 Pan Hd. ST T-20 Screw	(1)
13	-----	Housing Cover - Right Housing Halve	(1)
14	05-88-1200	M4 x 16mm Pan Hd. ST T-20 Screw	(11)
15	05-74-0015	M6 x 21.5mm, 5mm Hex socket Cap Screw	(4)
19	44-60-0068	Clamping Knob	(1)
20	-----	Quick Release Casting	(1)
21	40-50-1090	Spring	(1)
22	05-78-0027	M6 x 50mm Hex Hd. Machine Screw	(1)
23	45-72-0013	Quick Change Trigger	(1)
24	05-81-0592	M4 x 6.5mm Flat Head T-15 Screw	(1)
25	42-92-0047	Trigger Cover	(1)
26	05-74-0026	M6 x 30mm Cap Hd. Hex Socket Screw	(1)
29	42-68-0292	Carrier Handle Clip	(2)
30	05-55-0006	M6 Hex Nut	(2)
31	-----	Carrier Handle	(1)
32	45-72-0083	On-Off Trigger	(1)
33	40-50-0374	Bias Spring	(1)
34	40-50-0373	Spring	(1)
39	06-82-5270	6-32 x 1/4" Pan Hd. Tapt. T-15 Screw	(1)
40	05-74-0012	M4 x 20mm Pan Hd. T-20 Machine Screw	(1)
41	45-88-0825	Flat Washer	(1)
42	05-55-0004	M4 Hex Nut	(1)
45	06-82-7240	6-19 x 1/2" Pan Hd. ST T-15 Screw	(4)
46	44-52-0001	Rubber Pad with Adhesive (Set of 2)	(1)
47	-----	Lower Cover Halve - Left	(1)
48	-----	Housing Support - Left Housing Halve	(1)

FIG.	PART NO.	DESCRIPTION OF PART	NO. REQ.
49	-----	Motor Insulator - Left	(1)
51	02-04-0034	Ball Bearing	(1)
76	45-88-0011	Flat Washer	(1)
83	12-20-0156	Service Nameplate	(1)
90	14-20-0078	Electronics Assembly	(1)
91	31-44-0156	Housing Kit	(1)
92	31-44-0181	Lower Cover Kit	(1)
93	31-50-0023	Motor Insulator Kit	(1)
94	16-01-0036	Rotor/Motor Mount Assembly	(1)
95	14-34-0124	Carrier Handle Assembly	(1)
96	45-72-0036	Lock-Off Trigger Assembly	(1)
97	45-08-0031	Drive Shaft Assembly (For Power Unit)	(1)
98	14-02-0010	Quick Release Assembly	(1)
100	43-24-2825	Drive Shaft/Quick Release Assy. (Power Unit)	(1)
	10-20-1788	Warning Label (Not Shown)	(1)
	10-20-1789	Warning Label (Not Shown)	(1)

No. 49-16-2718 Edge Trimmer Attachment

FIG.	PART NO.	DESCRIPTION OF PART	NO. REQ.
1	45-04-0016	M8 x 15mm Hex Head LH Machine Screw	(1)
2	43-34-2718	Blade Flange	(1)
3	42-26-2718	Edger Blade	(1)
4	43-78-0031	Edger Blade Mounting Hub	(1)
6	05-78-0029	M5 x 8mm Pan Hd. T-25 Machine Screw	(5)
7	05-78-0032	M5 x 13mm Pan Hd. T-25 Machine Screw	(4)
8	44-66-0038	Edger Skid Plate	(1)
9	43-54-0016	Edger A Guard	(1)
10	43-54-0018	Flexible Rear Guard	(1)
11	14-29-0033	Gearbox Assembly	(1)
12	05-78-0033	M5 x 20mm Pan Hd. T-25 Machine Screw	(2)
13	42-40-0013	Sleeve Bushing	(1)
14	45-94-0017	Edger Wheel	(1)
15	45-88-0077	Flat Washer	(1)
16	05-90-0016	Split Ring Lock washer	(1)
17	43-98-0027	Clamping Knob	(1)
18	06-10-0012	M6 x 65mm Square Neck Carriage Bolt	(1)
19	42-36-0033	Edger Wheel Bracket	(1)
25	45-96-1001	Wrench	(1)
30	45-08-0027	Drive Shaft Assembly (For Edge Trimmer)	(1)
	10-20-1782	Warning Label (Not Shown)	(1)

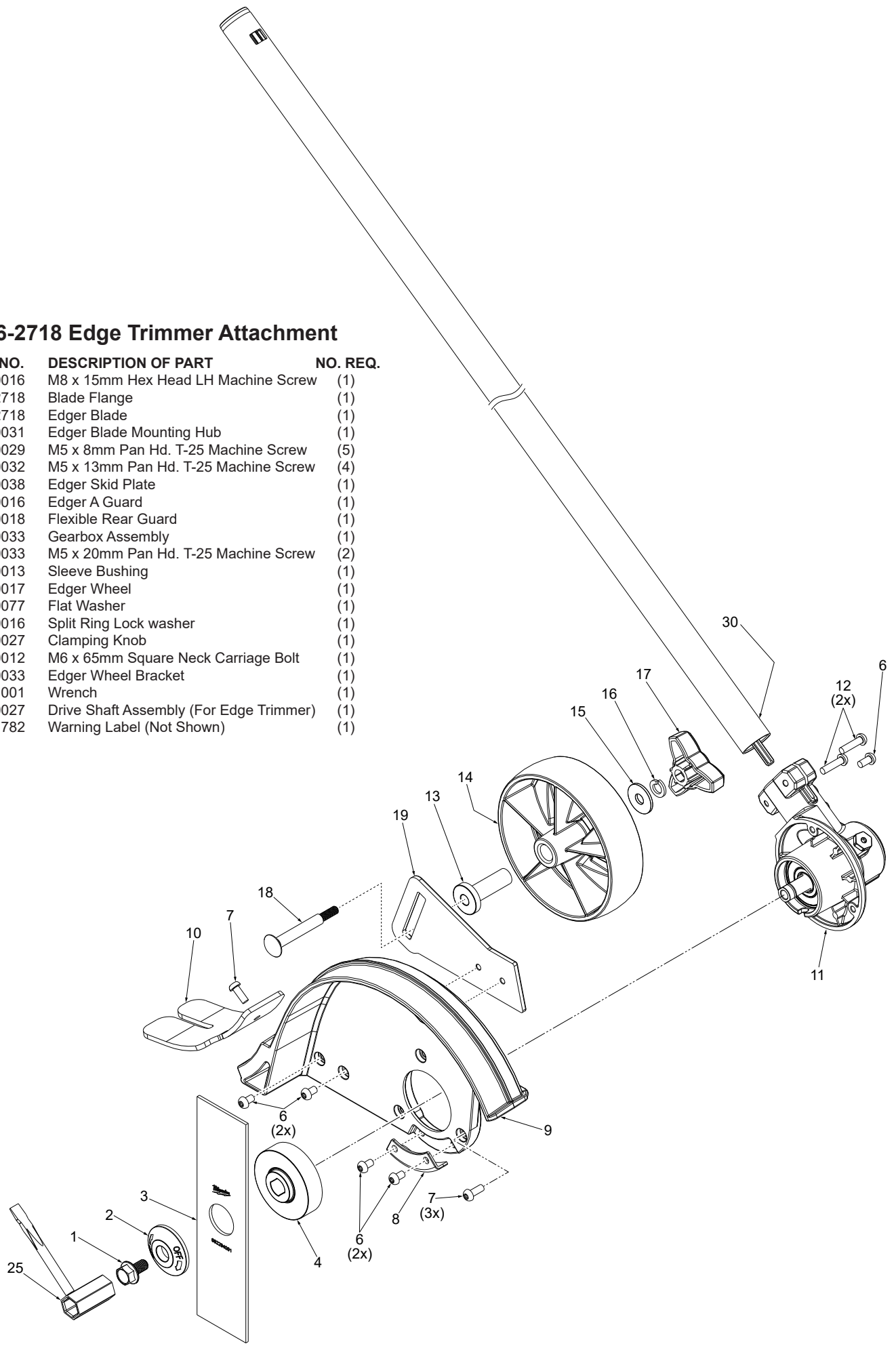

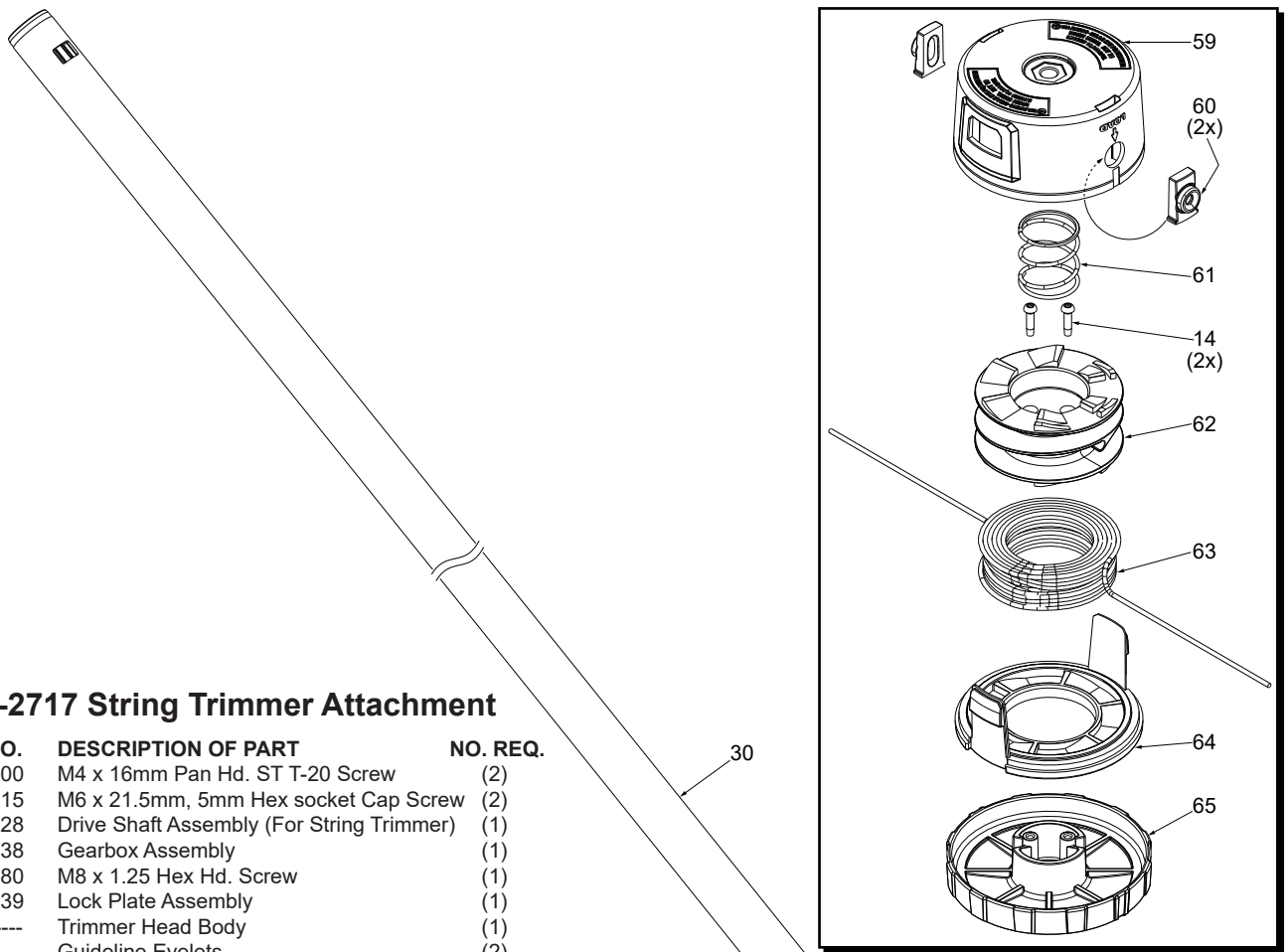

No. 49-16-2717 String Trimmer Attachment

FIG.	PART NO.	DESCRIPTION OF PART	NO. REQ.
14	05-88-1200	M4 x 16mm Pan Hd. ST T-20 Screw	(2)
15	05-74-0015	M6 x 21.5mm, 5mm Hex socket Cap Screw	(2)
30	45-08-0028	Drive Shaft Assembly (For String Trimmer)	(1)
57	14-29-0038	Gearbox Assembly	(1)
57p	05-85-0080	M8 x 1.25 Hex Hd. Screw	(1)
58	44-66-0139	Lock Plate Assembly	(1)
59	-----	Trimmer Head Body	(1)
60	-----	Guideline Eyelets	(2)
61	-----	Trimmer Head Spring	(1)
62	-----	Spool	(1)

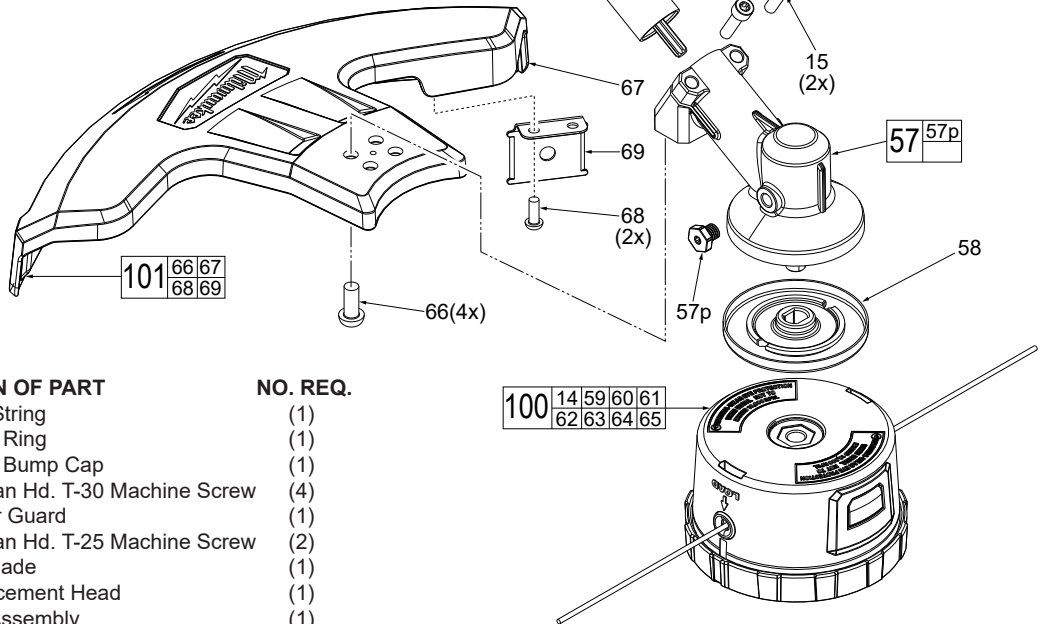
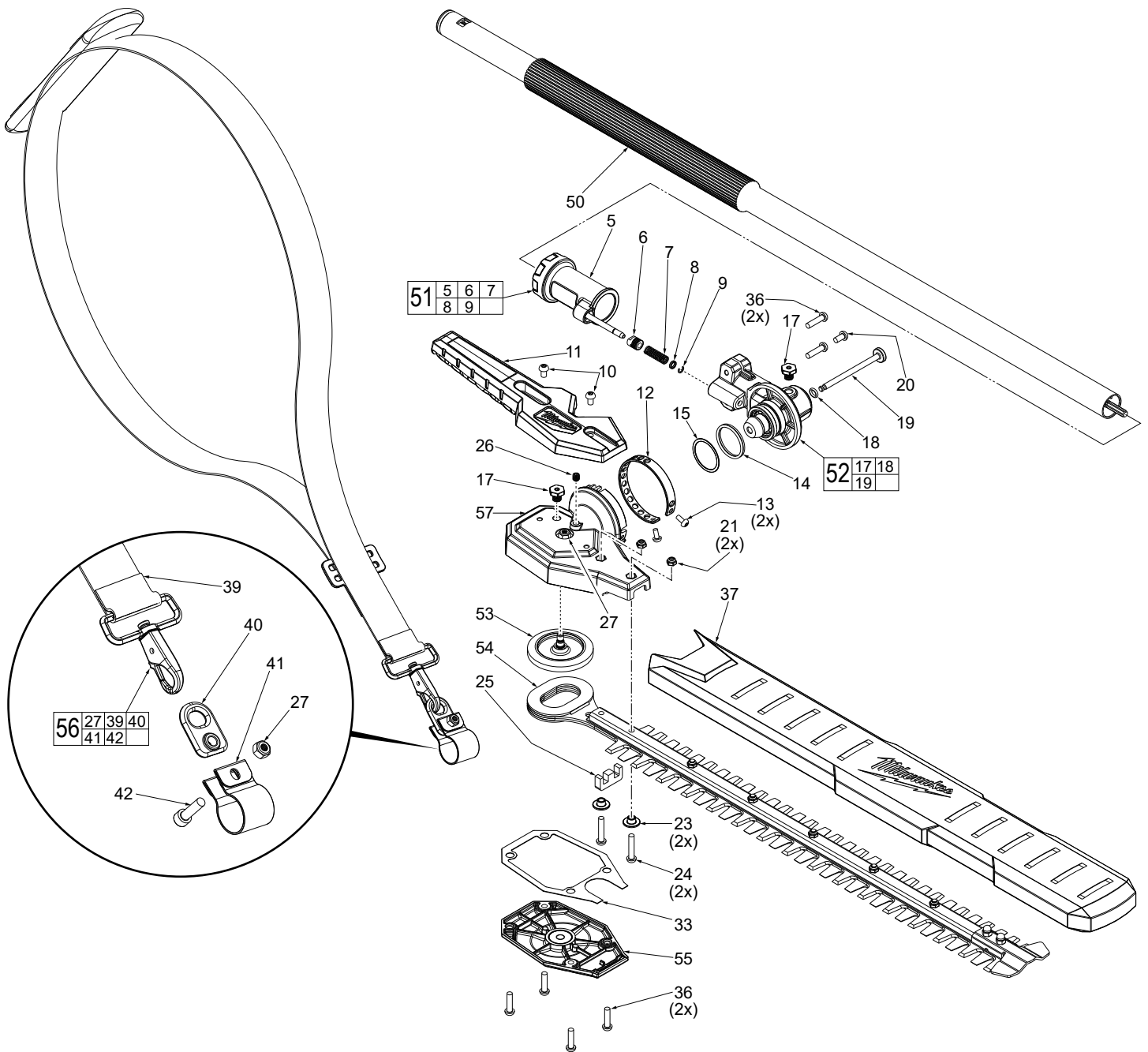
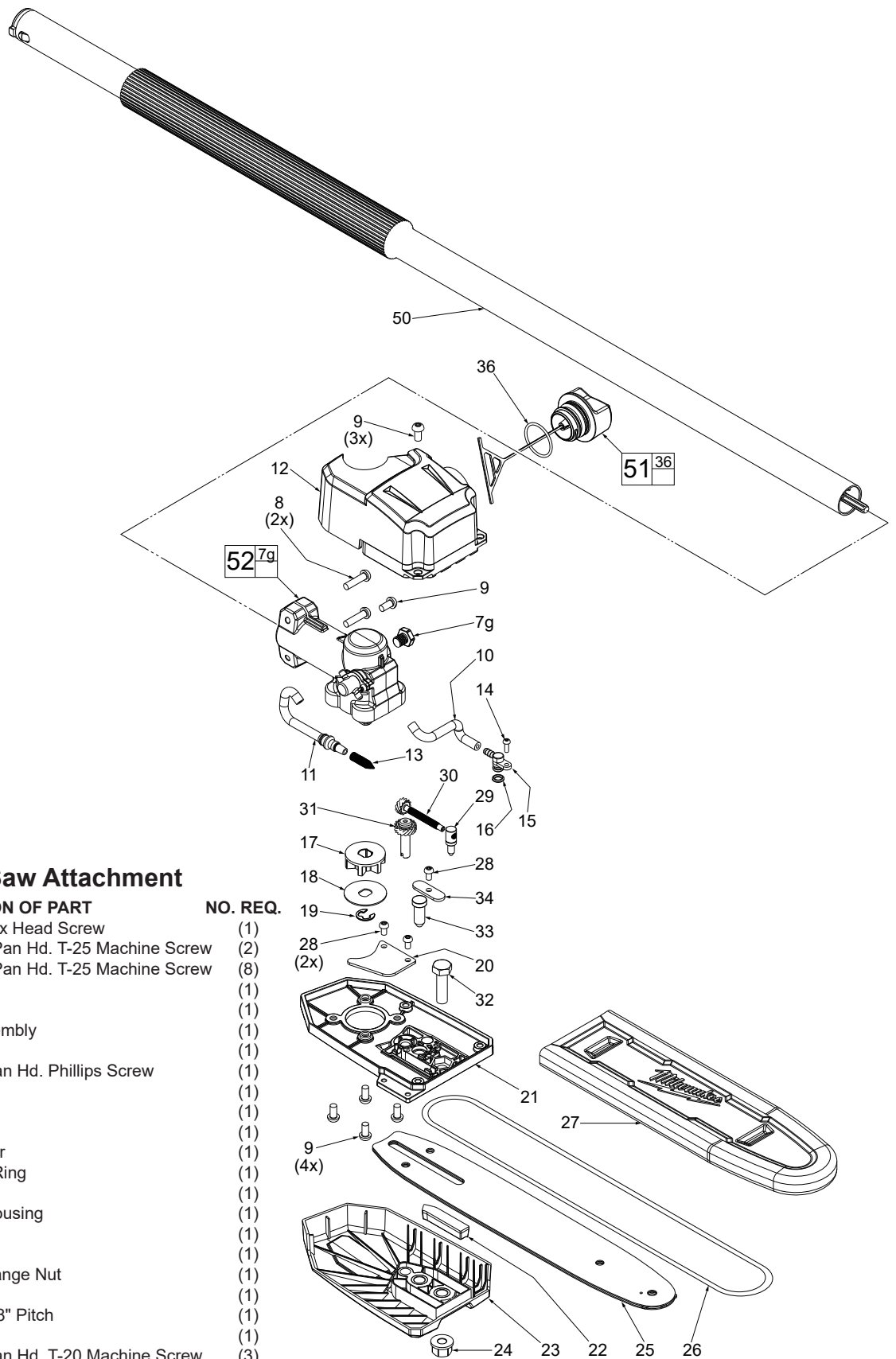

FIG.	PART NO.	DESCRIPTION OF PART	NO. REQ.
63	-----	0.080" x 150' String	(1)
64	-----	Trimmer Head Ring	(1)
65	-----	Trimmer Head Bump Cap	(1)
66	05-81-0132	M6 x 14mm Pan Hd. T-30 Machine Screw	(4)
67	-----	String Trimmer Guard	(1)
68	05-74-0935	M5 x 15mm Pan Hd. T-25 Machine Screw	(2)
69	42-26-0024	Line Cut-Off Blade	(1)
100	49-16-2714	Loaded Replacement Head	(1)
101	14-32-0012	String Guard Assembly	(1)
	10-20-1781	Warning Label (Not Shown)	(1)



No. 49-16-2719 Hedge Trimmer Attachment

FIG.	PART NO.	DESCRIPTION OF PART	NO. REQ.	FIG.	PART NO.	DESCRIPTION OF PART	NO. REQ.
5	-----	Handle with Locking Pin	(1)	37	49-62-0011	Blade Sheath	(1)
6	06-38-0021	Threaded Stud	(1)	39	-----	Shoulder Strap	(1)
7	40-50-0114	Lock Pin Spring	(1)	40	44-66-0039	Shoulder Strap Mounting plate	(1)
8	45-88-0078	Flat Washer	(1)	41	45-56-0011	Shoulder Strap Mounting Band	(1)
9	34-60-0023	C Retaining Ring	(1)	42	05-74-0015	M6 x 21.5mm Cap Hd. T-30 Machine Screw	(1)
10	05-78-0029	M5 x 8mm Pan Hd. T-25 Machine Screw	(2)	50	45-08-0023	Drive Shaft Assembly (For Hedge Trimmer)	(1)
11	31-44-0127	Hedge Trimmer Handle	(1)	51	14-34-0011	Handle Assembly with Locking Pin	(1)
12	42-16-0011	Detent Band	(1)	52	14-29-0014	Gearbox Assembly	(1)
13	05-78-0038	M4 x 7mm Pan Hd. T-20 Machine Screw	(2)	53	14-29-0015	Gear/Crankshaft Assembly	(1)
14	34-40-0126	O-Ring	(1)	54	42-26-0016	Blade Assembly	(1)
15	45-88-0079	Flat Washer	(1)	55	31-15-0067	Gearbox Cover with Ball Bearing	(1)
17	05-85-0080	M8 x 1.25 Hex Hd. Screw	(2)	56	45-56-0012	Shoulder Strap Assembly	(1)
18	34-40-4002	O-Ring	(1)	57	43-76-2719	Hedge Trimmer Housing Assembly	(1)
19	44-60-0069	Gear Alignment Pin	(1)	10-20-1783	Warning Label (Not Shown)	(1)	
20	05-78-0024	M5 x 10mm Pan Hd. T-25 Machine Screw	(1)				
21	05-55-0019	M5 Nylon Hex Nut	(2)				
23	42-40-0123	Bushing	(2)				
24	05-78-0019	M5 x 26mm Pan Hd. T-25 Machine Screw	(2)				
25	45-06-0016	Felt Seal	(1)				
26	06-83-0017	M6 x 8mm Cone Point Set Screw	(1)				
27	06-57-0625	M5 Nylon Insert Hex Nut	(2)				
33	43-44-0026	Gasket	(1)				
36	05-78-0033	M5 x 20mm Pan Hd. T-25 Machine Screw	(6)				



No. 49-16-2720 Pole Saw Attachment

FIG.	PART NO.	DESCRIPTION OF PART	NO. REQ.
7g	05-85-0080	M8 x 1.25 Hex Head Screw	(1)
8	05-78-0033	M5 x 20mm Pan Hd. T-25 Machine Screw	(2)
9	05-78-0024	M5 x 10mm Pan Hd. T-25 Machine Screw	(8)
10	45-36-0016	Outlet Tube	(1)
11	45-76-0011	Inlet Tube	(1)
12	45-66-0013	Oil Tank Assembly	(1)
13	40-50-9220	Cone Spring	(1)
14	05-81-0015	M3 x 6mm Pan Hd. Phillips Screw	(1)
15	42-86-0012	Connector	(1)
16	34-40-4002	O-Ring	(1)
17	45-44-0010	Sprocket	(1)
18	45-88-7001	Chain Washer	(1)
19	42-70-5268	Retaining E-Ring	(1)
20	43-74-0011	Hook	(1)
21	42-92-0057	Bar Mount Housing	(1)
22	43-84-0013	Insert Block	(1)
23	43-72-0014	Bar Holder	(1)
24	05-55-5001	13mm M8 Flange Nut	(1)
25	48-09-5001	10" Bar	(1)
26	49-16-2723	10" Chain, 3/8" Pitch	(1)
27	49-62-0015	Scabbard	(1)
28	05-78-0038	M4 x 7mm Pan Hd. T-20 Machine Screw	(3)
29	05-89-0017	Chain Tensioning Post	(1)
30	05-89-0018	Chain Tensioner Main Screw	(1)
31	05-81-9001	Chain Tensioner Adjustment Screw	(1)
32	05-85-0012	M8 x 28mm Hex Head Machine Screw	(1)
33	44-50-0015	Locating Pin	(1)
34	44-66-0089	Plate	(1)
36	34-40-9002	Oil Cap O-Ring	(1)
50	45-08-0029	Drive Shaft Assembly (For Pole Saw)	(1)
51	42-52-3001	Oil Cap Assembly	(1)
52	14-29-0016	Gearbox Assembly	(1)
	10-20-1784	Warning Label (Not Shown)	(1)

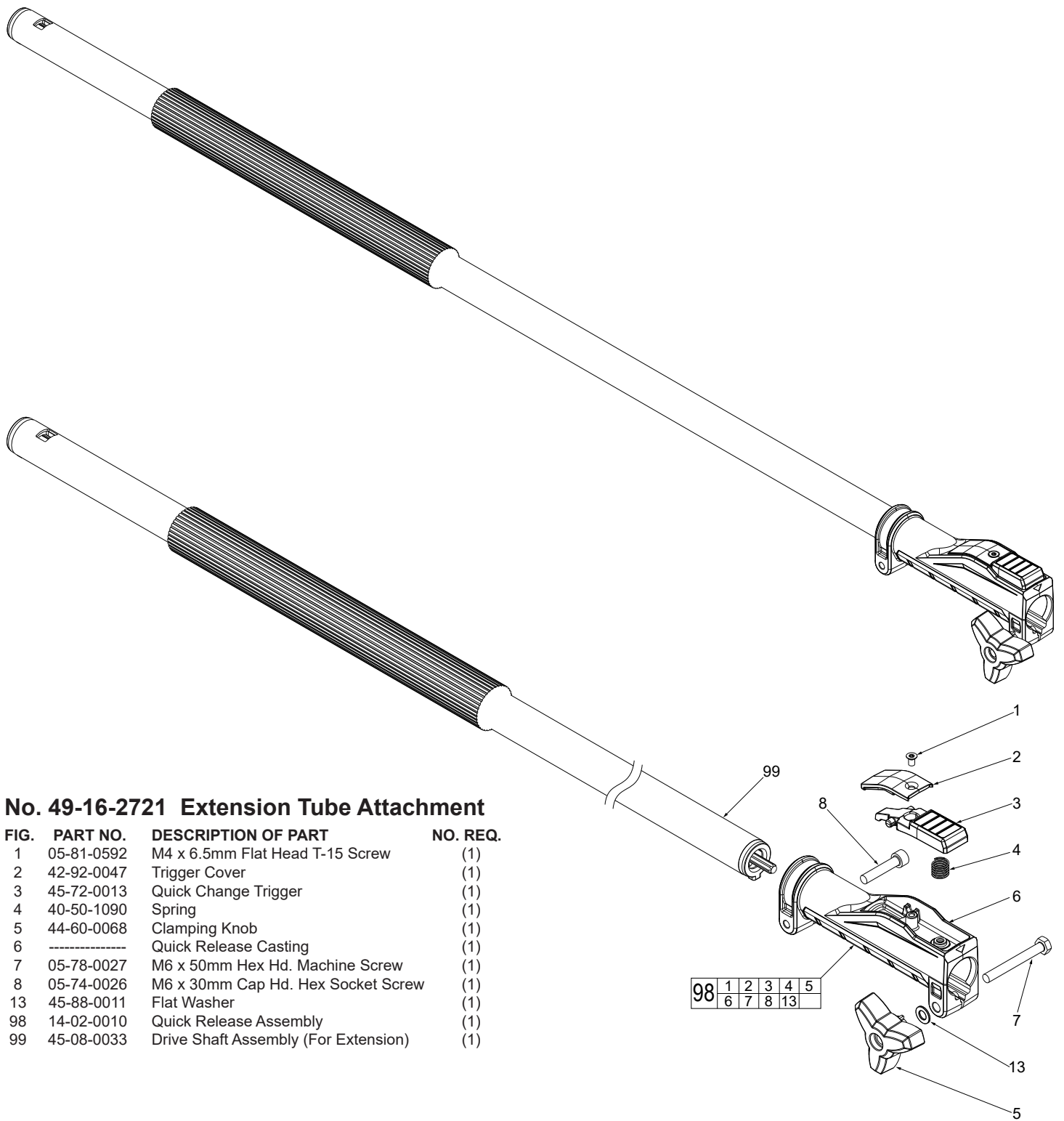

No. 49-16-2721 Extension Tube Attachment

FIG.	PART NO.	DESCRIPTION OF PART	NO. REQ.
1	05-81-0592	M4 x 6.5mm Flat Head T-15 Screw	(1)
2	42-92-0047	Trigger Cover	(1)
3	45-72-0013	Quick Change Trigger	(1)
4	40-50-1090	Spring	(1)
5	44-60-0068	Clamping Knob	(1)
6	-----	Quick Release Casting	(1)
7	05-78-0027	M6 x 50mm Hex Hd. Machine Screw	(1)
8	05-74-0026	M6 x 30mm Cap Hd. Hex Socket Screw	(1)
13	45-88-0011	Flat Washer	(1)
98	14-02-0010	Quick Release Assembly	(1)
99	45-08-0033	Drive Shaft Assembly (For Extension)	(1)

98	1	2	3	4	5
	6	7	8	13	

SERVICE WIRING DIAGRAM

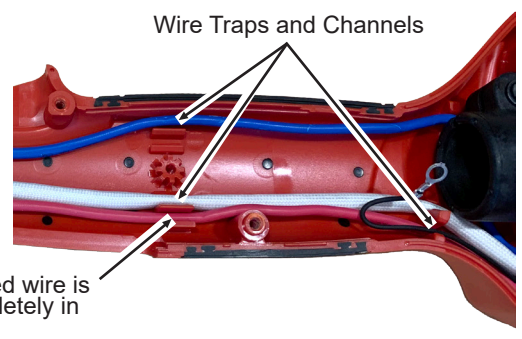
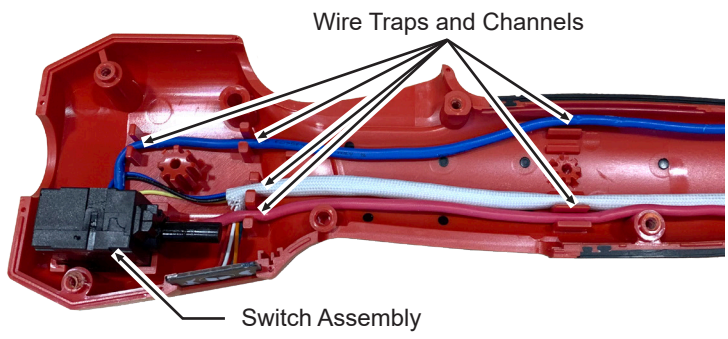

Make sure red wire is placed completely in wire trap.

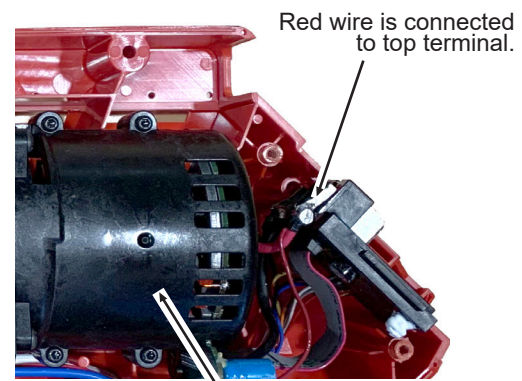
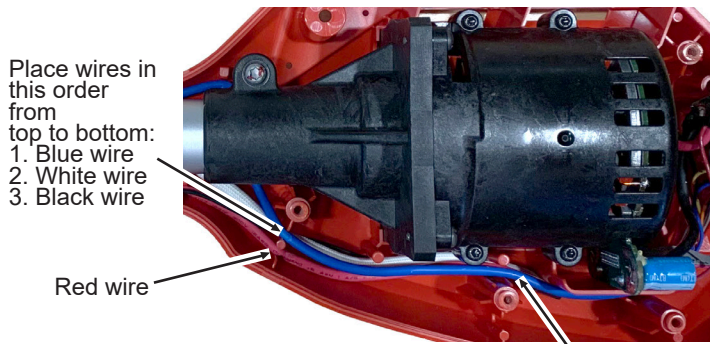

Place wires in this order from top to bottom:
1. Blue wire
2. Red Wire
3. White wire

