



Item #  
Model #

## USE AND CARE GUIDE

---

### LAGUNA POINT CAPTURED GLASS SIDE TABLE

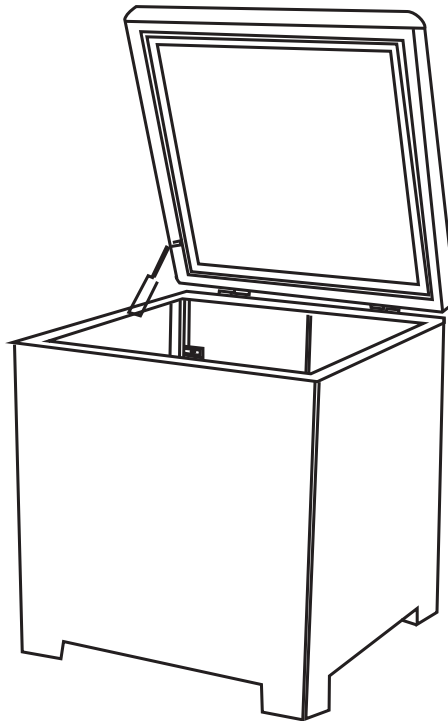

Questions, problems, missing parts? Before returning to the store,  
call Hampton Bay Customer Service  
8 a.m. - 6 p.m., EST, Monday

**1-855-HD-HAMPTON**

**HAMPTONBAY.COM**

---

#### **THANK YOU**

*Appreciate the trust and confidence you have placed in Hampton Bay through the purchase of this table. We strive to continually create quality products designed to enhance your home. Visit us online to see our full line of products available for your home improvement needs. Thank you for choosing Hampton Bay!*

# Table of Contents

<b>Table of Contents</b> .....	<b>2</b>	<b>Pre-Assembly</b> .....	<b>3</b>
<b>Safety Information</b> .....	<b>2</b>	Planning Assembly.....	3
Set Up Your Furniture Properly.....	2	Hardware Included.....	3
Examine Your Furniture.....	2	Package Contents.....	4
Observe Weight Limits.....	2	<b>Assembly</b> .....	<b>5</b>
<b>Warranty</b> .....	<b>2</b>	<b>Care and Cleaning</b> .....	<b>6</b>
What is Covered.....	2		
What is Not Covered.....	2		

# Safety Information

## SET UP YOUR FURNITURE PROPERLY

- Ensure that all parts are assembled properly and fully tightened as per the instructions.
- When placing in the desired location, ensure that all legs are resting on the same surface.

## EXAMINE YOUR FURNITURE

- Examine occasionally to ensure that there are no loose parts. If loose parts are found, they must be re-tightened fully before additional use.

## OBSERVE WEIGHT LIMITS

The weight limits for the following products are listed below:

- |  |   |
|--|---|
| <input type="checkbox"/> Chair: 300 lbs        | <input type="checkbox"/> Sofa: 700 lbs          |
| <input type="checkbox"/> Swivel Chair: 300 lbs | <input type="checkbox"/> Rocking Chair: 300 lbs |
| <input type="checkbox"/> Loveseat: 500 lbs     | <input type="checkbox"/> Chaise Lounge: 300 lbs |
| <input type="checkbox"/> Ottoman: 150 lbs      | <input type="checkbox"/> Dining Table: 100 lbs  |
| <input type="checkbox"/> Table: 50 lbs         | <input type="checkbox"/> Dining Chair: 200 lbs  |



**CAUTION:** If you overload your furniture, injuries can occur.

# Warranty

## TWO YEAR FRAME, WEAVE AND FABRIC LIMITED WARRANTY

### WHAT IS COVERED

We warrant the frame, weave and fabric to be free of manufacturing defects to the original purchaser for two years. For glass table top we warrant 30 days from the date of purchase.

### WHAT IS NOT COVERED

This warranty does not cover commercial use, hardware, acts of nature, fire, freezing and abusive use. In addition, purchased parts are not covered under this warranty.

We reserve the right to make substitutions with similar merchandise, if the model in question is no longer in production.

Contact the Customer Service Team at 1-855-HD-HAMPTON or visit [www.Hamptonbay.com](http://www.Hamptonbay.com).

# Pre-Assembly

## PLANNING ASSEMBLY

To prevent damage, place all parts on a soft surface during assembly. Remove all protective caps before beginning assembly.

## HARDWARE INCLUDED

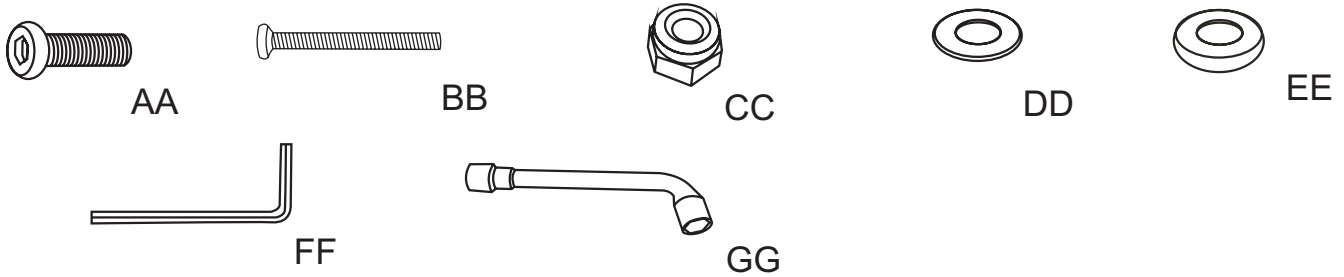

Part	Description	Quantity
AA	Bolt $\Phi 1/4 \times 20$ mm	13
BB	Long Bolt $\Phi 1/4 \times 55$ mm	2
CC	Locking nut $\Phi 6$ mm	2
DD	Washer $\Phi 6$ mm	17
EE	Plastic washer $\Phi 6$ mm	1
FF	Hex wrench 4mm	1
GG	Wrench #11	1

# Pre-Assembly (continued)

## PACKAGE CONTENTS

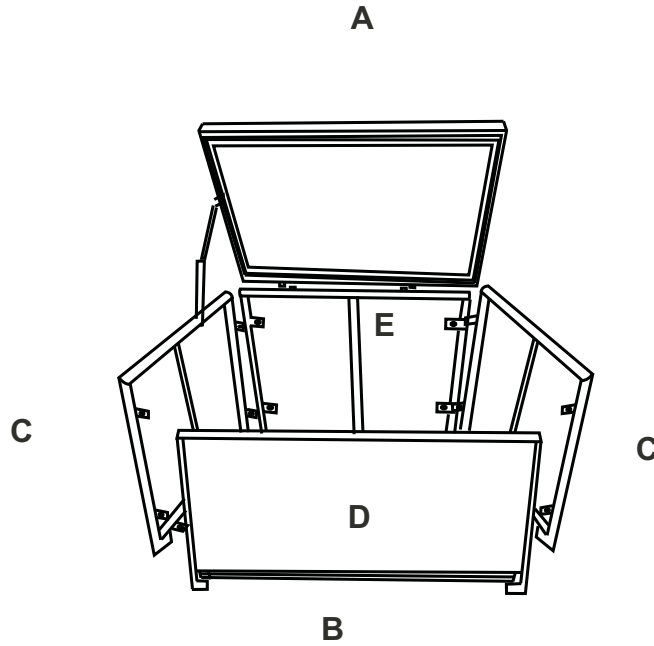

Part	Description	Quantity
A	Table top	1
B	Base	1
C	Side skirts	2
D	Front skirt	1
E	Back skirt	1

# Assembly

## 1 Attaching to side skirts to the back skirt

- Place the back skirt (E) on a soft surface.
- Attach the right side skirt (C) to the back skirt (E), fasten with bolts (AA) and washer (DD). Tighten half way using the Hex wrench (FF).
- Repeat previous step for the other side skirt .

Fig1

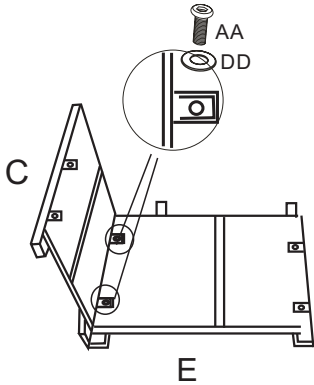
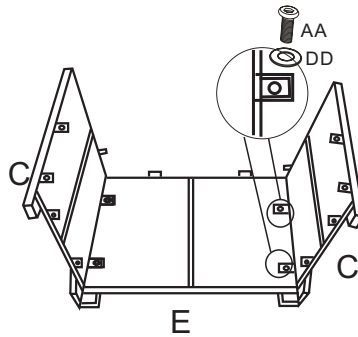
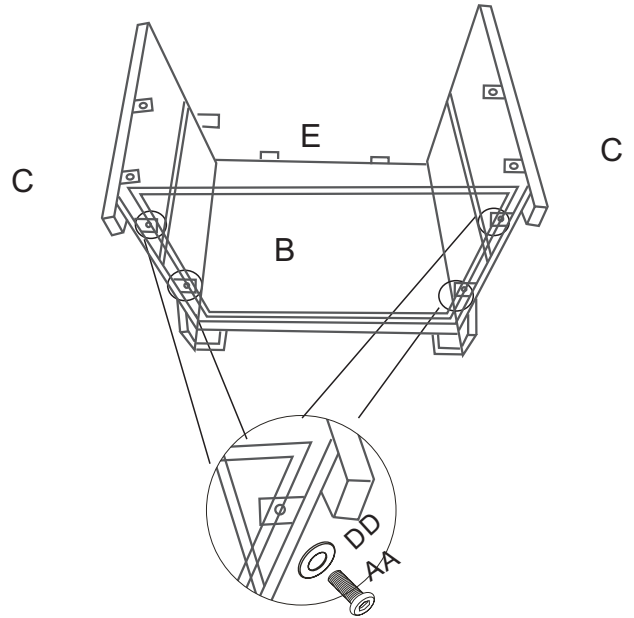

Fig2



## 2 Attaching the base

- Put the base (B) on side skirt (C) as shown ,fasten with bolts (AA) with washers (DD). Tighten half way using the Hex wrench (FF).



## 3 Attaching the front side

- Put the assembling table onto the front (D).
- Tighten with bolts (AA) with washers (DD). Do not fully tighten .

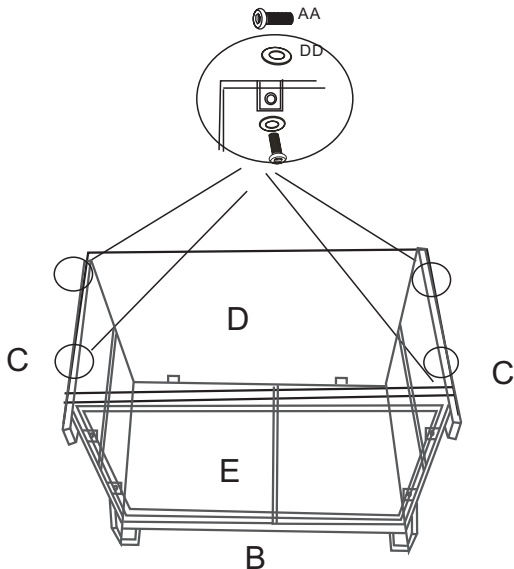

## 4 Fastening the bolts

- Turn the assembling storage box upward as shown.
- Check and make adjustment as needed. Fully tighten all the bolts (AA) with Hex wrench (FF).

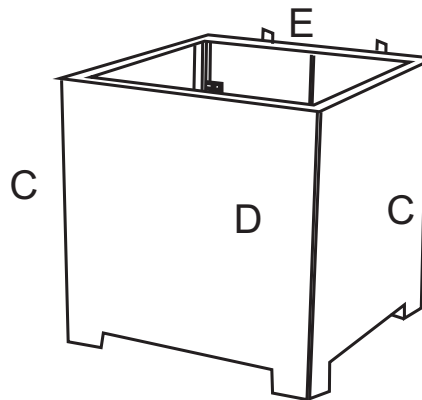

# Assembly

## 5 Attaching the top

- Make the holes on (E) and top (A) in a line.
- Put long bolts(BB) going through the holes and tighten with locking nuts (CC) by using wrench (GG) and Hex wrench(FF), fully tighten.

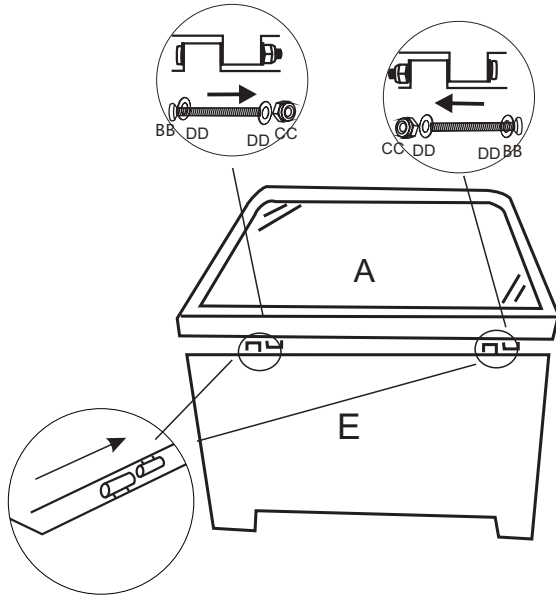

## 6 Completing the assembly

- Attach side skirt (C) by aligning hole on the top (A) with the hole on the piston.
- Insert a bolt (AA) with washer (DD) and (EE), fully tighten with Hex wrench (FF).
- This table is now ready for your enjoyment.

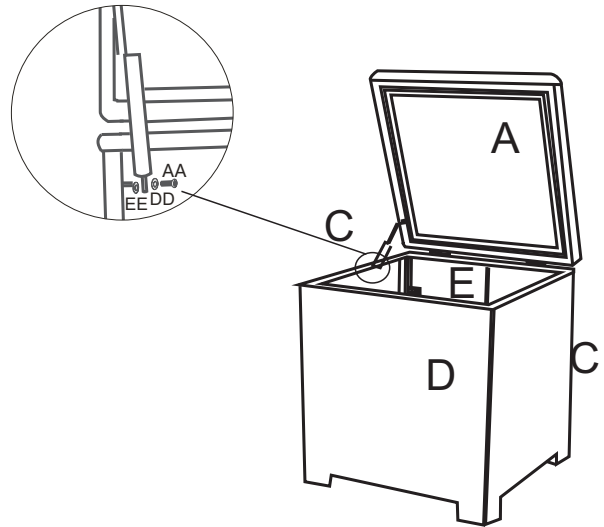

## Care and Cleaning

---

- Before using, wipe with a clean, dry cloth. Do not use bleach or solvents. When not in use, store furniture in a cool, dry place.
- If your set includes cushions or mesh fabric, they may be cleaned by hand with a mild solution of soap and water. Rinse cushion thoroughly and allow to drip dry. Do not machine wash or tumble dry, as cushions may shrink.
- Do not use bleach or solvents on fabrics. When cleaning the table top make sure to use a soft, clean cloth that does not bleed color as well.



Questions, problems, missing parts? Before returning to the store,  
call Home Depot Customer Service  
8 a.m. - 6 p.m., EST, Monday-Friday

**1-855-HD-HAMPTON**

**HAMPTONBAY.COM**

Retain this manual for future use.