

HOME DECORATORS COLLECTION

1002959127 1002959126
1002959141 1002959142

SK18950r2 SADIE SINGLE HALL TREE WITH CUSHION 72"Hx21.5"Wx15.75"D

ASSEMBLY INSTRUCTIONS

Made In China

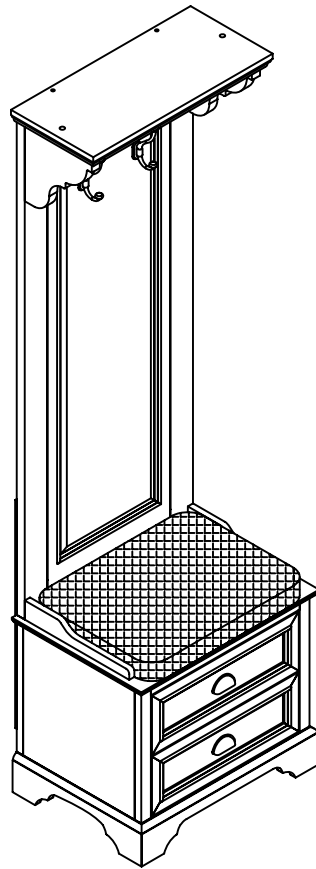

Thank you for purchasing this quality product. Be sure to check all packing material carefully for small parts, which may have come loose inside the carton during shipment. Count all parts and material hardware, then compare with parts list to be sure all parts are present, If any parts are missing or damaged, phone, fax, or mail to our Customer service Department for efficient and speedy service. Please indicate the model number and code letter of part(s) needed.

IMPORTANT NOTE: Follow instructions listed below in proper sequence as numbered to assure fast,easy and correct assembly.

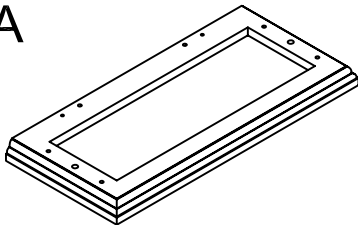
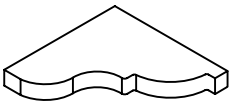
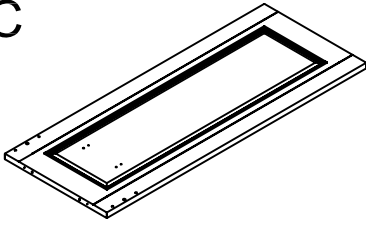
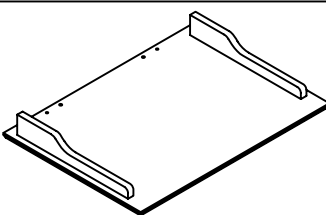
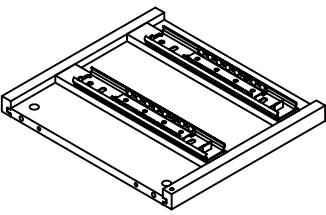
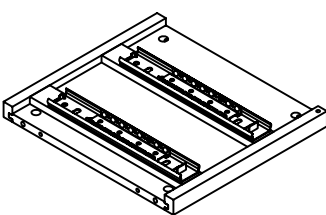
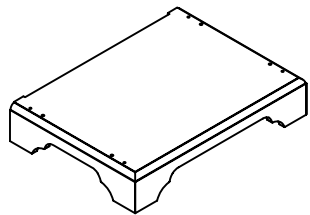
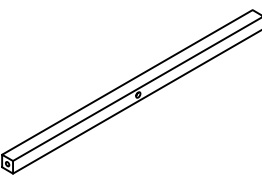
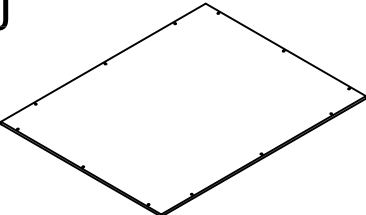
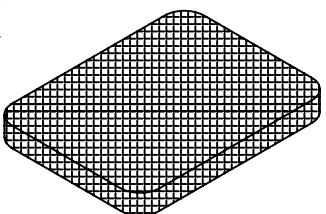
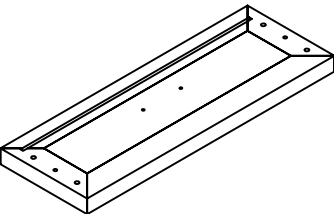
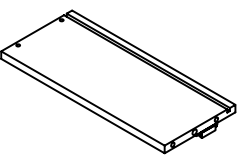
PARTS LIST		
A  TOP PANEL-1PC	B  PARTITION-2PCS	C  TOP BACK PANEL-1PC
D  FIXED PANEL-1PC	F  LEFT SIDE PANEL-1PC	G  RIGHT SIDE PANEL-1PC
H  BOTTOM PANEL-1PC	I  FRONT CROSS BRACE-1PC	J  BOTTOM BACK PANEL-1PC
K  CUSHION-1PC	L  DRAWER FRONT PANEL-2PCS	M  DRAWER LEFT SIDE PANEL-2PCS

N

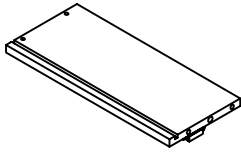

DRAWER
RIGHT SIDE PANEL-2PCS

O

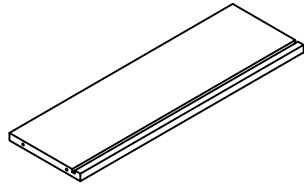





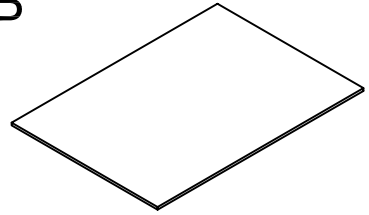





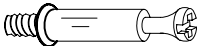

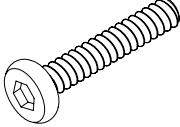

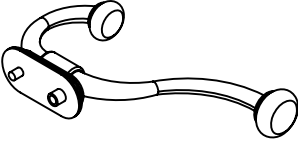
DRAWER BACK PANEL-2PCS

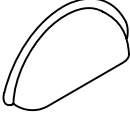
P

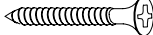
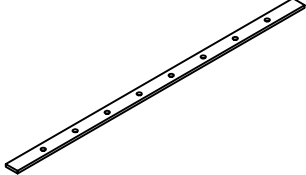
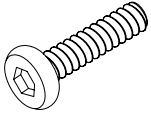

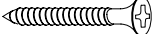
DRAWER
BOTTOM PANEL-2PCS

NOTE:THE SURFACE WITH THE STICKER IS THE BACK SIDE

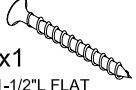
<p>a</p>  <p>WOOD DOWEL-30PCS</p>	<p>b</p>  <p>CAM LOCK BOLT-12PCS</p>	<p>c</p>  <p>CAM LOCK-12PCS</p>			
<p>d</p>  <p>PLASTIC COVER-4PCS</p>	<p>e</p>  <p>Ø1/4"X1-1/4" L BOLT-6PCS</p>	<p>f</p>  <p>5/8" ROUND HEAD SCREW-12PCS</p>			
<p>g</p>  <p>POTHOOK-2PCS</p>	<p>h</p>  <p>Ø5/32"X10mm POTHOOK BOLT-2PCS</p>	<p>i</p>  <p>DRAWER HANDLE-2PCS</p>			
<p>j</p>  <p>Ø5/32"X5/8" L DRAWER HANDLE BOLT-4PCS</p>	<p>k</p>  <p>1" L FLAT HEAD SCREW-9PCS</p>	<p>l</p>  <p>METAL PLATE-2PCS</p>			
<p>m</p>  <p>1" L BOLT-16PCS</p>	<p>n</p>  <p>ALLEN WRENCH-1PC</p>	<p>o</p>  <p>1-1/4" L FLAT HEAD SCREW-2PCS</p>			
	<p>1  x2 RECTANGLE METAL PLATE</p> <p>2  x1 5/8" L FLAT HEAD SCREW</p> <p>3  x1 PLASTIC ANCHOR</p> <p>4  x1 PLASTIC BAND</p> <p>5  x1 1-1/2" L FLAT HEAD SCREW</p> <p>ANTI-TIPPING HARDWARE PACKAGE</p>				

NOTE:THE SURFACE WITH THE STICKER IS THE BACK SIDE

HOW TO SEPARATE GLIDES

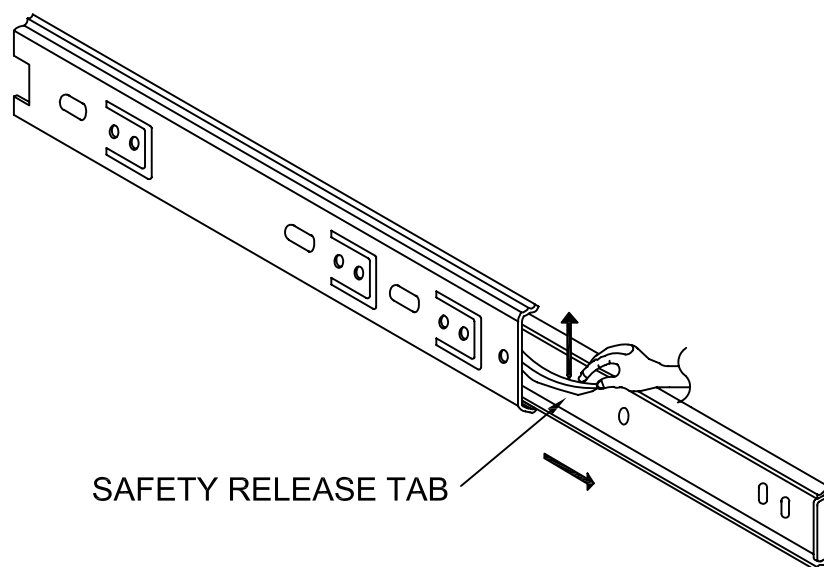

PRIOR TO ASSEMBLY, WE SUGGEST SEPARATING THE INNER GLIDES FROM THE OUTER-GLIDES, SIMPLY PULL THE LEFT/RIGHT INNER GLIDES FROM THE OUTER GLIDES EXPOSING A SMALL BLACK SAFETY RELEASE TAB, BY PUSHING THE SAFETY RELEASE TAB. YOU WILL BE ABLE TO SEPARATE THE GLIDES.

NOTE: • UPON OPENING, THOROUGHLY CLEAN ALL WOOD SURFACES TO REMOVE DUST AND DIRT THAT MAY HAVE SETTLED ONTO THE FINISH DURING SHIPMENT. IN ORDER TO PREVENT DAMAGE DURING ASSEMBLY. PLEASE ASSEMBLE THIS ITEM WITH AT LEAST TWO PEOPLE.

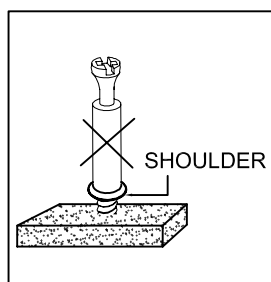
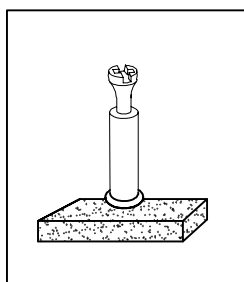

NOTE: TURN THE CAM-BOLT SCREWS UNTIL THEY ARE TIGHT, THE SHOULDER SHOULD BE AGAINST THE SURFACE OF THE PART.

HOW TO USE THE CAM-TOOL

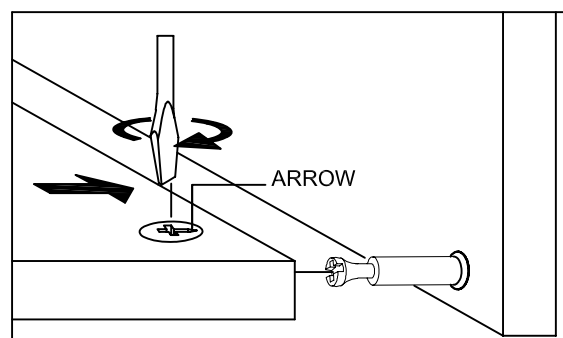
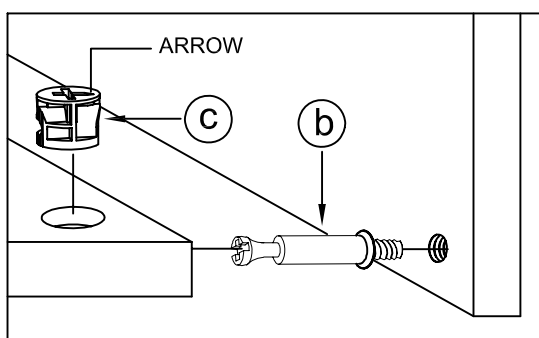

NOTE: • THE ARROWS ON THE HIDDEN CAM-LOCKS SHOULD POINT TO THE CAM-BOLTS.

FIG 1

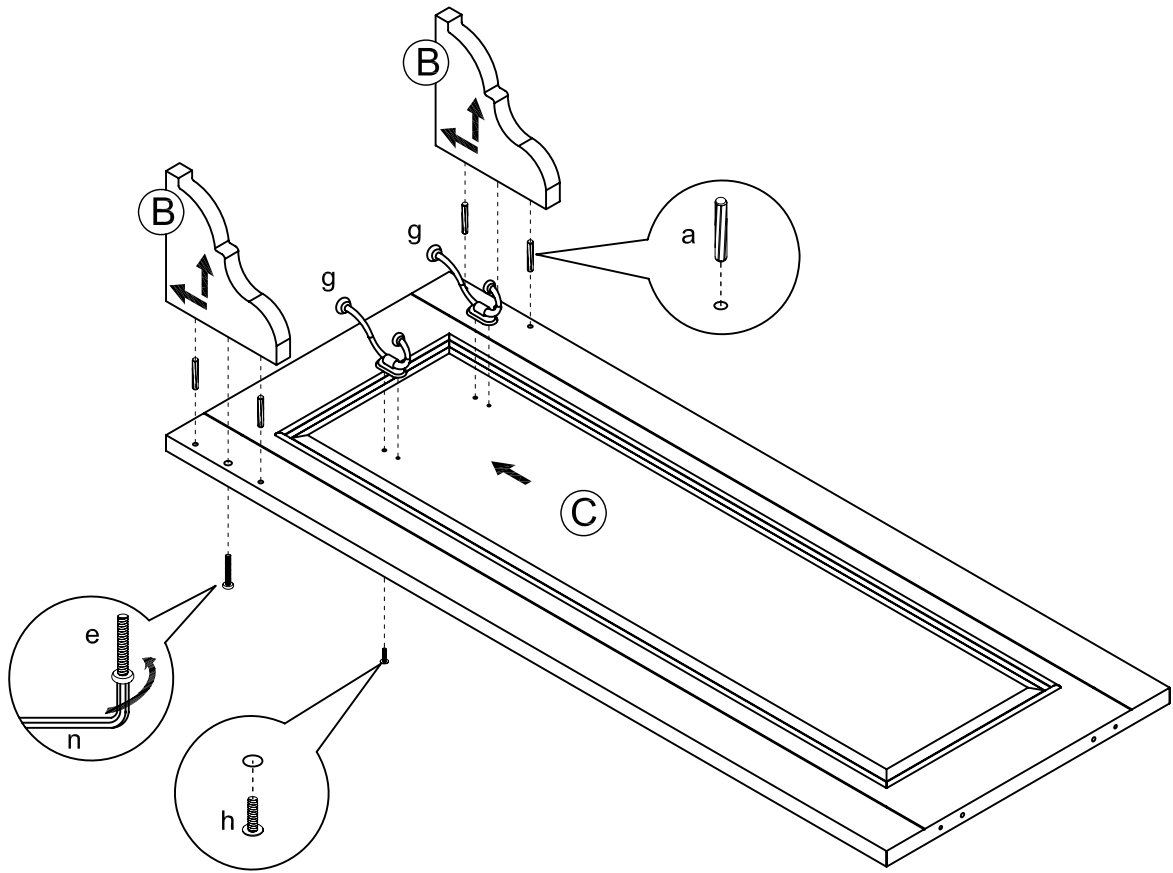

- ATTACH THE POTHOOK (g) TO THE TOP BACK PANEL (C) BY USING THE $\text{Ø}5/32 \times 10\text{mm}$ BOLT (h).
- JOIN THE PARTITION (B) TO THE TOP BACK PANEL (C) BY USING WOOD DOWEL (a) FIRST.
- TIGHTEN THE PARTITION (B) BY USING THE $\text{Ø}1/4 \times 1-1/4\text{L}$ BOLT (e) WITH THE ALLEN WRENCH (n) AS SHOWN.

FIG 2

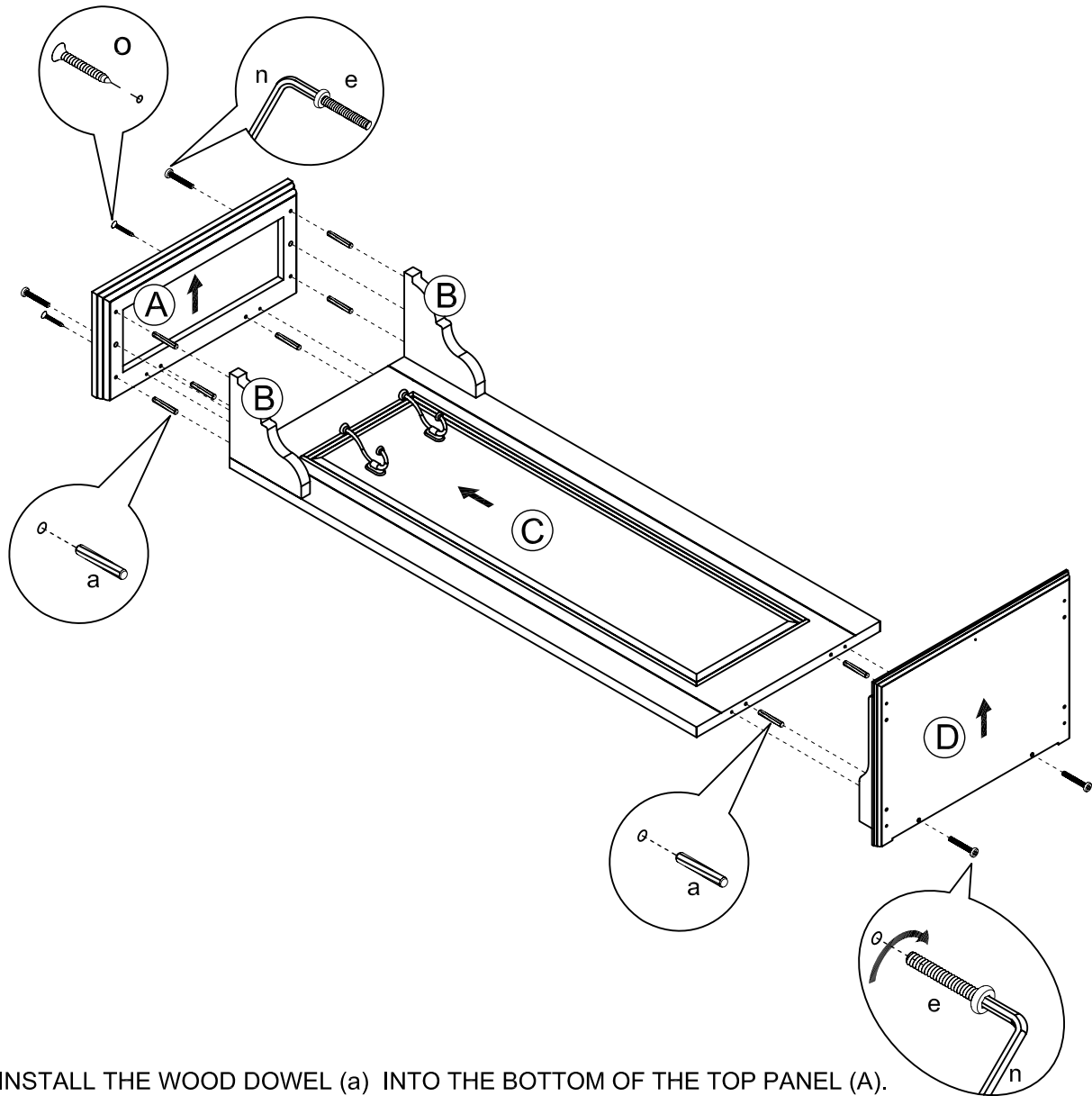

- INSTALL THE WOOD DOWEL (a) INTO THE BOTTOM OF THE TOP PANEL (A).
- JOIN THE TOP PANEL (A) TO THE ASSEMBLED PART BY USING THE WOOD DOWEL (a) FIRST.
- TIGHTEN THE TOP PANEL (A) BY USING THE 1-1/4" L BOLT (e) WITH THE ALLEN WRENCH (n) AS SHOWN.
- TIGHTEN THE TOP PANEL (A) BY USING THE 1-1/4" L FLAT HEAD SCREW (o) THROUGH THE PRE-DRILLED HOLES AS SHOWN.
- INSTALL THE WOOD DOWEL (a) INTO THE TOP OF THE FIXED PANEL (D).
- JOIN THE FIXED PANEL (D) TO THE ASSEMBLED PART BY USING THE WOOD DOWEL (a) FIRST.
- TIGHTEN THE FIXED PANEL (D) BY USING THE 1-1/4" L BOLT (e) WITH THE ALLEN WRENCH (n) AS SHOWN.

FIG 3

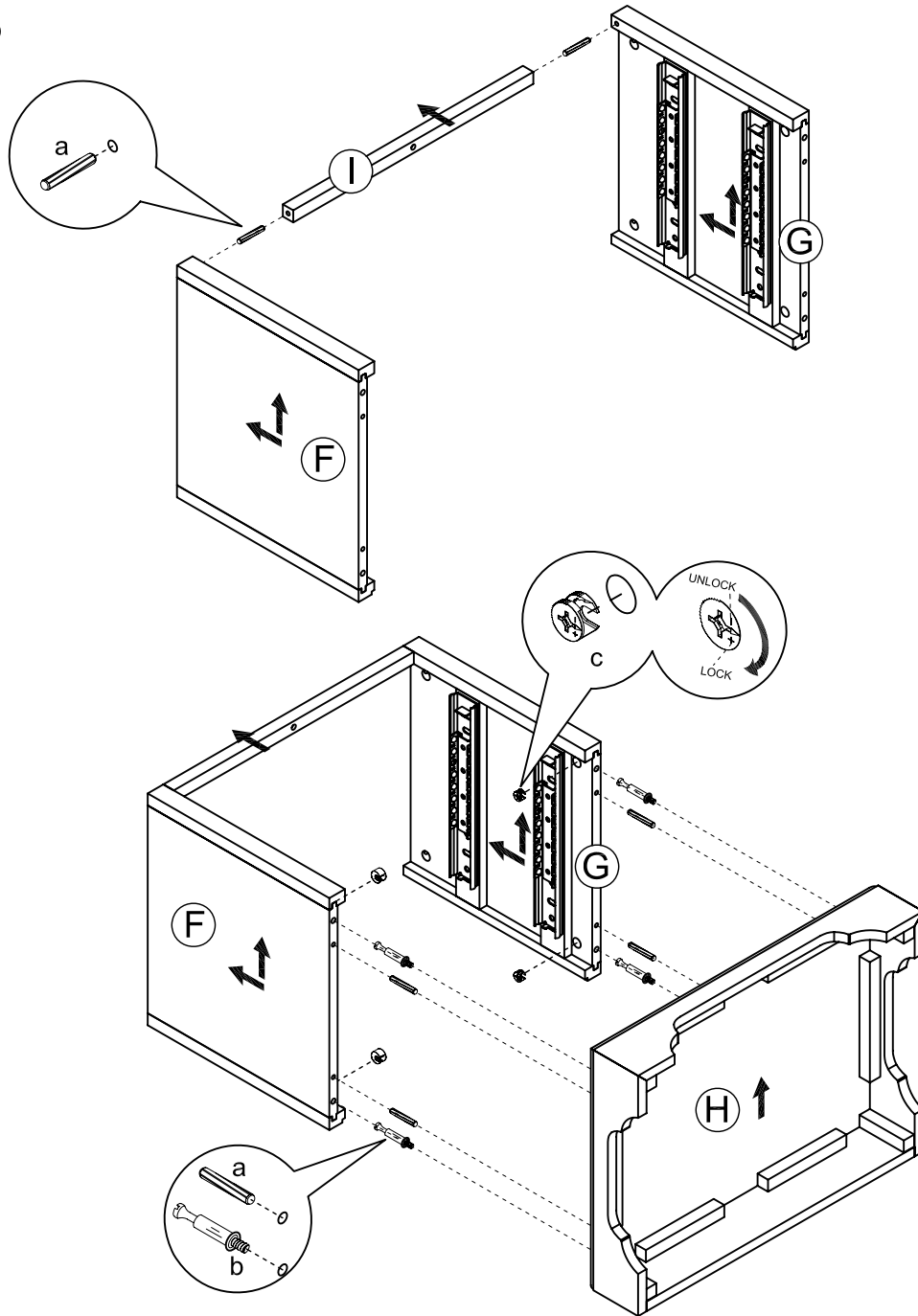

- INSTALL THE WOOD DOWEL (a) INTO THE FRONT CROSS BRACE (I).
- JOIN THE FRONT CROSS BRACE (I) TO THE BOTH SIDE PANELS (F) & (G) BY USING THE WOOD DOWEL (a) FIRST.
- INSTALL THE WOOD DOWEL (a) AND THE CAM LOCK BOLT (b) INTO THE TOP OF THE BOTTOM PANEL (H).
- JOIN THE BOTTOM PANEL (H) TO THE ASSEMBLED PART BY USING THE WOOD DOWEL (a) FIRST.
- TIGHTEN CAM LOCK BOLT (b) WITH THE CAM LOCK (c) IN THE PRE-DRILLED HOLES.

FIG 4

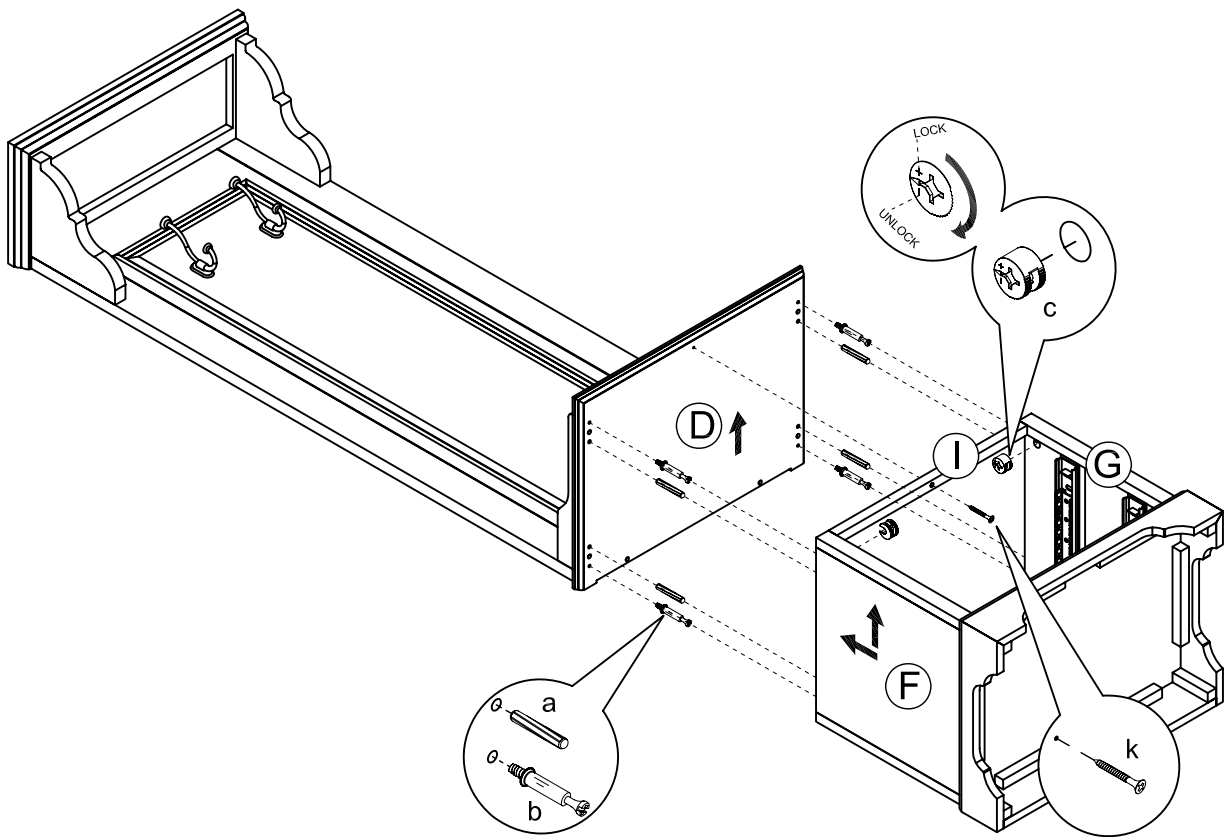

- INSTALL THE WOOD DOWEL (a) AND THE CAM LOCK BOLT (b) INTO THE BOTTOM OF THE FIXED PANEL (D).
- JOIN TWO ASSEMBLED PARTS BY USING THE WOOD DOWEL (a) FIRST.
- TIGHTEN CAM LOCK BOLT (b) WITH THE CAM LOCK (c) IN THE PRE-DRILLED HOLES.
- TIGHTEN THE FRONT CROSS BRACE (I) BY USING THE 1" L FLAT HEAD SCREW (k) THROUGH THE PRE-DRILLED HOLES AS SHOWN.

FIG 5

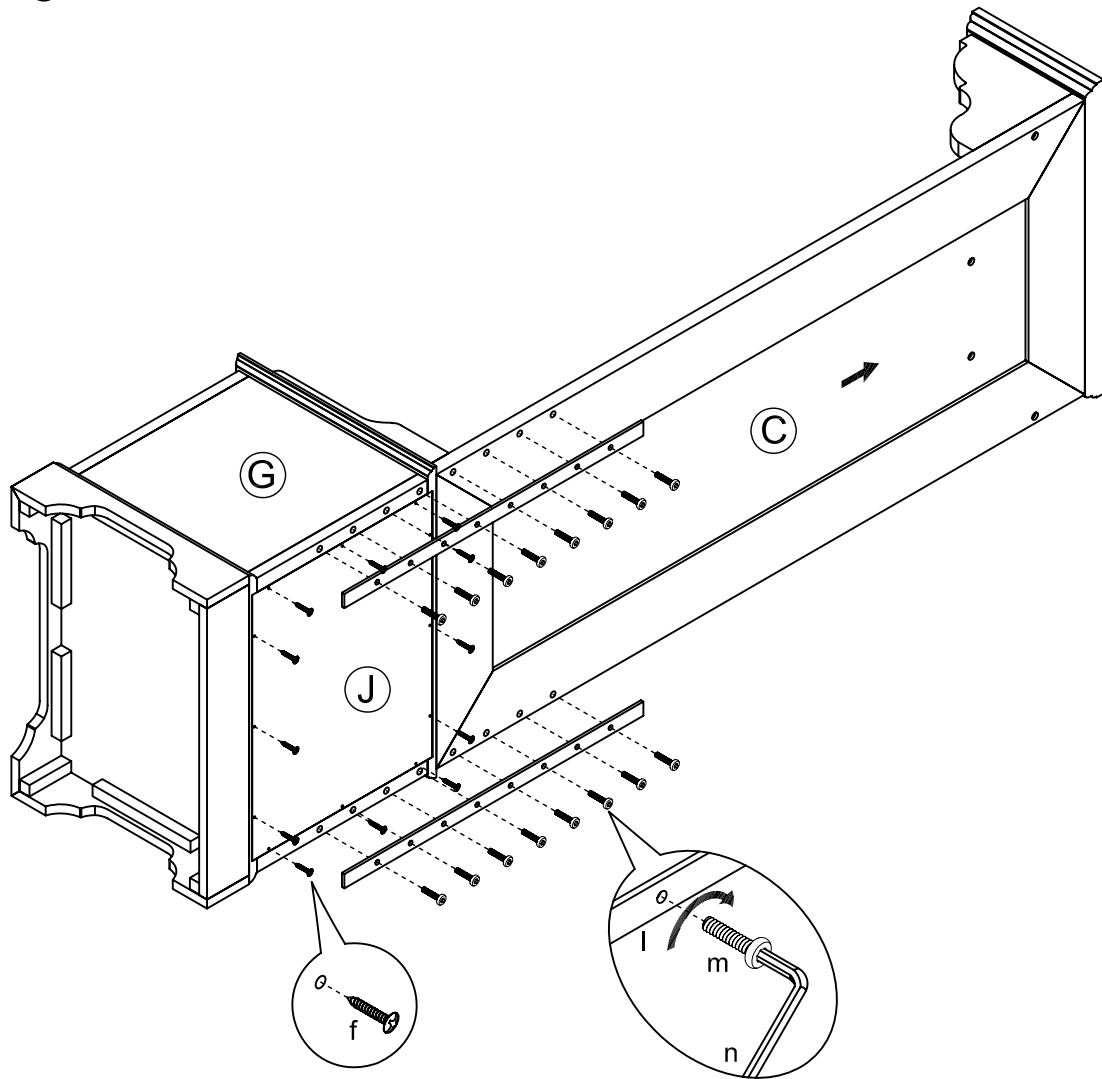

- TIGHTEN THE BOTTOM BACK PANEL (J) BY USING THE 5/8" L ROUND HEAD SCREW (f).
- ATTACH THE METAL PLATE (l) TO THE ASSEMBLED PART BY USING THE BOLT (m), TIGHTEN THE BOLT (m) WITH THE ALLEN WRENCH (n) AS SHOWN.

FIG 6

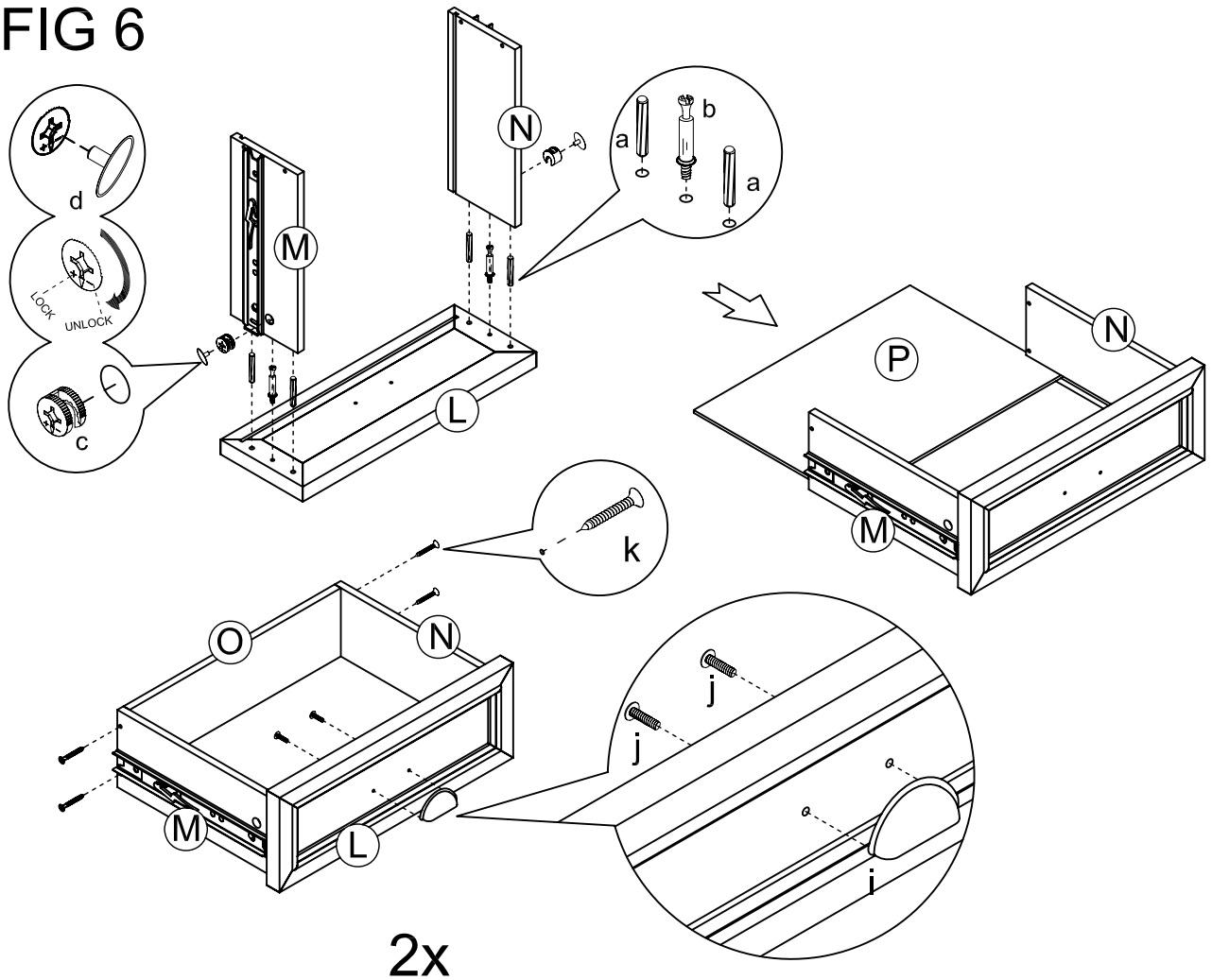

2x

- INSTALL THE WOOD DOWEL (a) AND THE CAM LOCK BOLT (b) INTO THE DRAWER FRONT PANEL (L).
- JOIN THE DRAWER LEFT SIDE PANEL (M) AND THE DRAWER RIGHT SIDE PANEL (N) TO THE DRAWER FRONT PANEL (L).
- ONCE JOINED, TIGHTEN CAM LOCK BOLT (b) WITH THE CAM LOCK (c) IN PRE-DRILLED HOLES.
- COVER CAM HOLES WITH THE PLASTIC COVER (d).
- SLIDE THE DRAWER BOTTOM PANEL (P) INTO THE GROOVES ON THE DRAWER LEFT SIDE PANEL (M) AND THE DRAWER RIGHT SIDE PANEL (N).
- JOIN THE DRAWER BACK PANEL (O) TO THE ASSEMBLED DRAWER PART AND TIGHTEN THE DRAWER BACK PANEL (O) BY USING THE 1" L FLAT HEAD SCREW (k) THROUGH PRE-DRILLED HOLES ON DRAWER SIDE PANELS.
- TIGHTEN THE DRAWER HANDLE (i) TO THE DRAWER FRONT PANEL (L) BY USING THE $\text{Ø}5/32 \times 5/8$ " L BOLT (j).

FIG 7

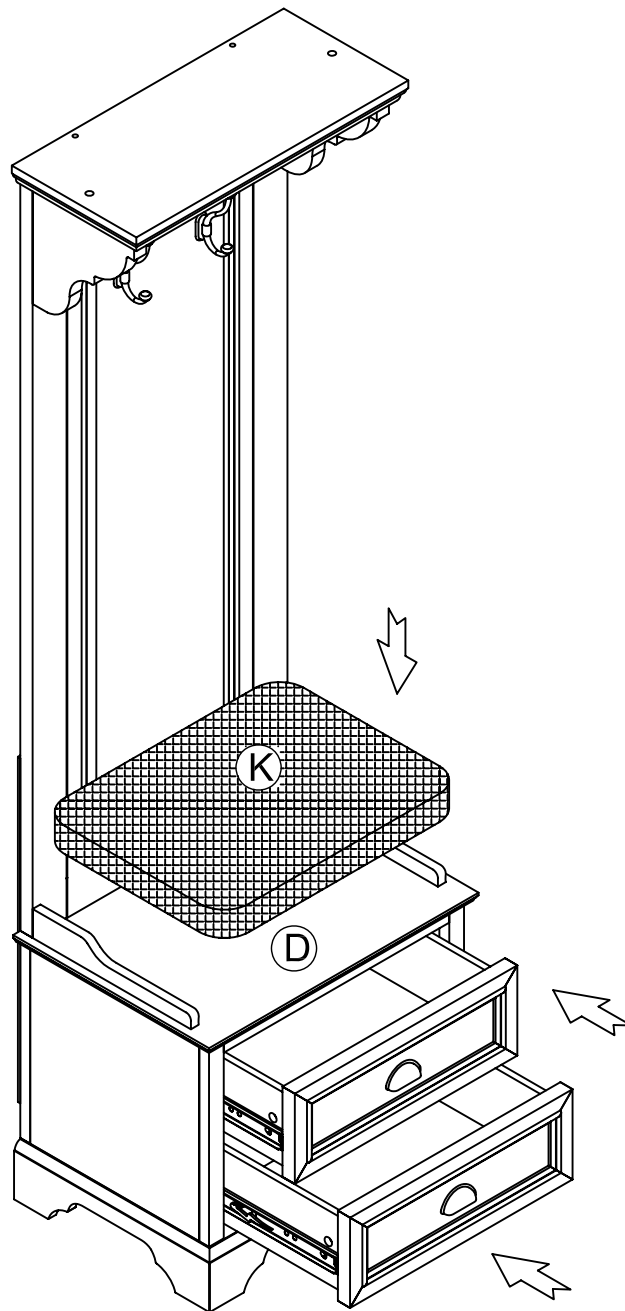

- INSERT DRAWERS INTO THE ASSEMBLED PART.
- PLACE THE CUSHION (K) ABOVE THE FIXED PANEL (D).

FIG 8

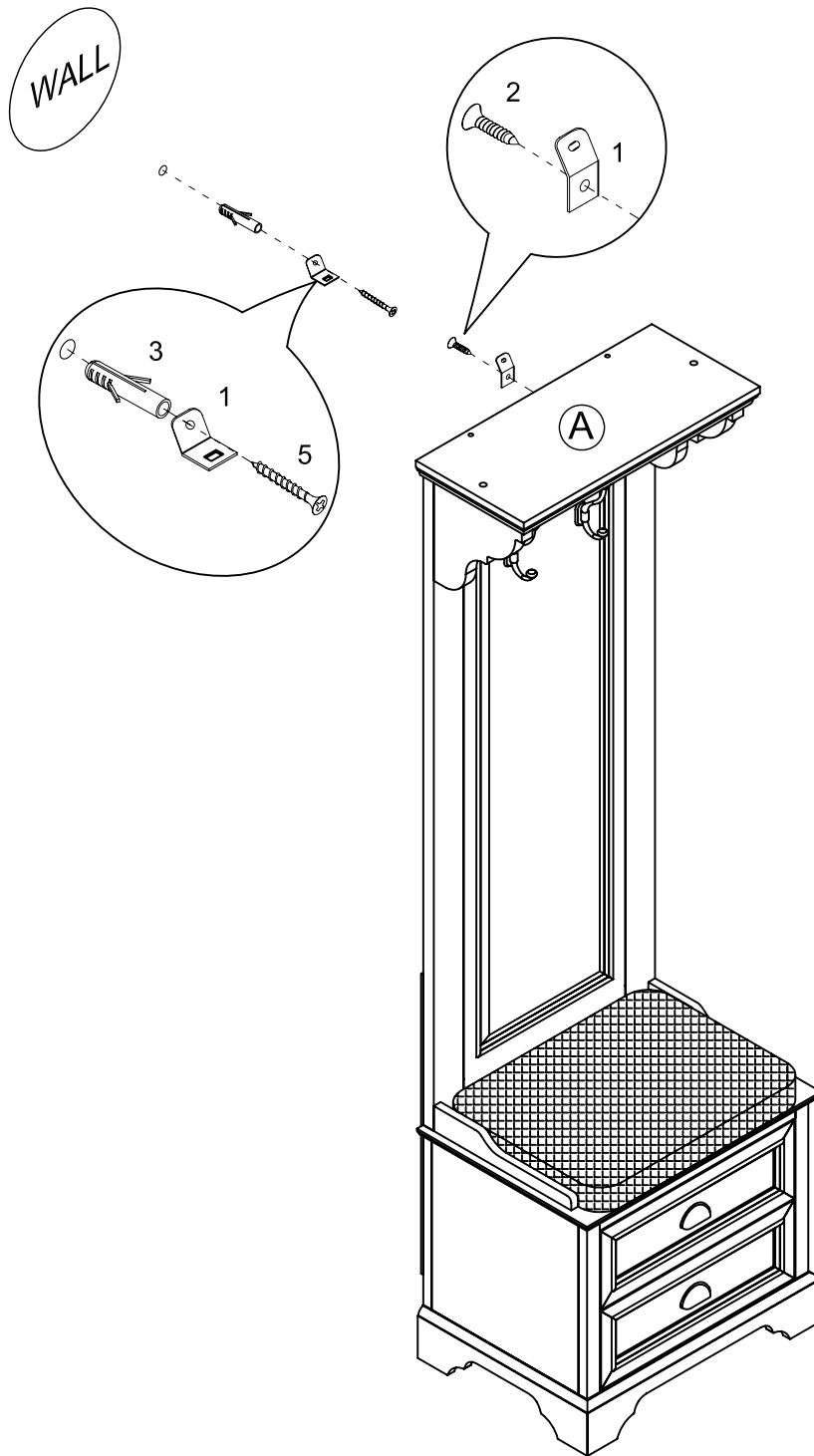

- TIGHTEN THE RECTANGLE METAL PLATE (1) TO THE REAR OF THE TOP PANEL (A) BY USING 1/2" FLAT HEAD SCREW (2).
- PLACE THE ASSEMBLED SADIE SINGLE HALL TREE AT THE DESIRED POSITION. MARK THE INSERTION POINTS FOR THE PLASTIC ANCHOR (3).
- USING THE PROPER HARDWARE FOR YOUR WALL TYPE, DRILL 1/4" HOLES INTO THE WALL.
- TIGHTEN THE RECTANGLE METAL PLATE (1) TO THE PLASTIC ANCHOR (3) BY USING THE 1-1/2" FLAT HEAD SCREW (5).

FIG 9

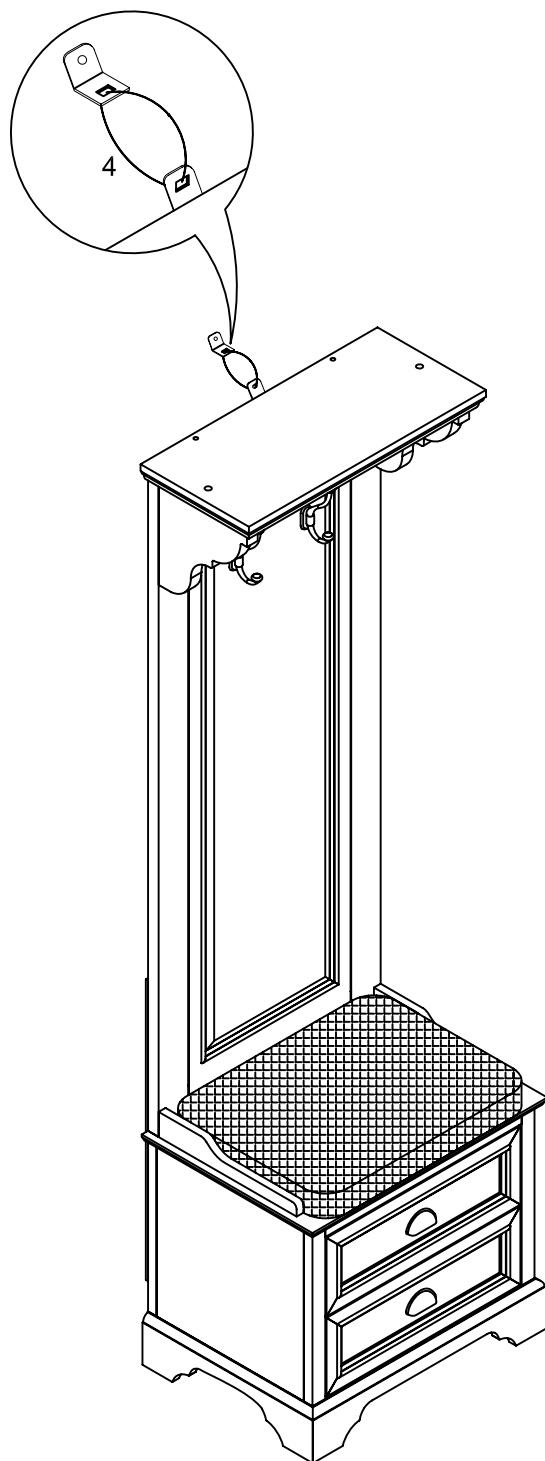

- USING THE PLASTIC BAND (4) CONNECT TWO RECTANGLE METAL PLATES (1).