

Pre-Installation

SPECIFICATIONS

Cup Size (CC)	Spray Pattern (in)	Tip Size (mm)	Weight (lbs)	Length (in)	Maximum Operating Pressure (PSI)	Air Cons. (SCFM)
600	1.2 - 9.2	1.4 & 2.2	1.17	6.25	40	4.3

PACKAGE CONTENTS

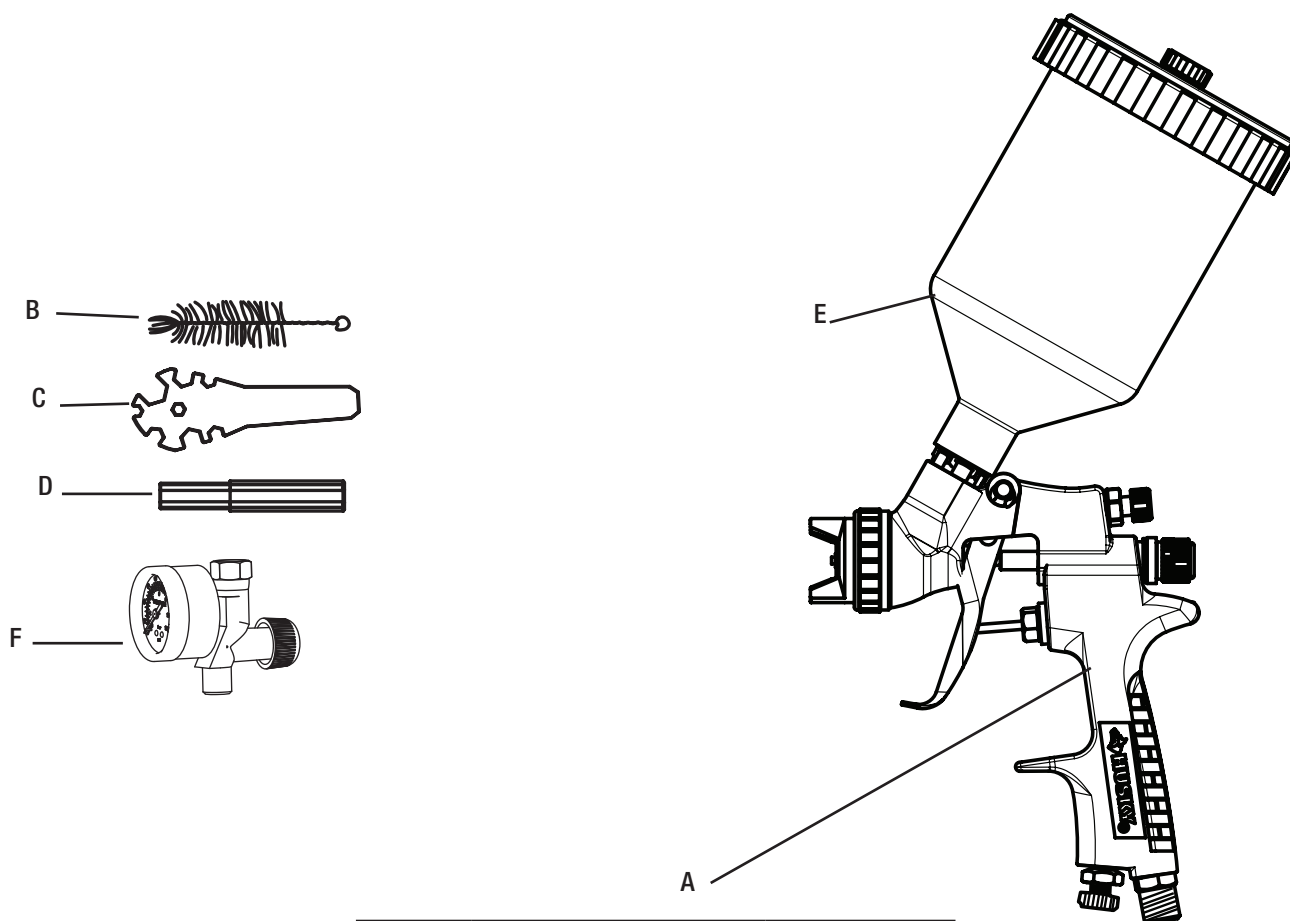

Part	Description	Quantity
A	Spray Gun	1
B	Cleaning Brush	1
C	Wrench	1
D	Socket Spanner	1
E	Paint Cup	1
F	Regulator	1