

# 10ft Closet System

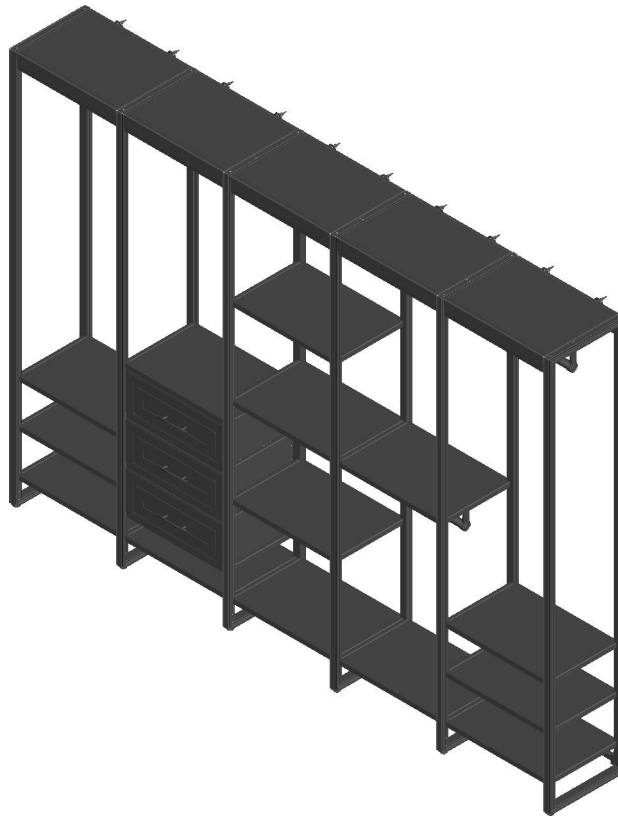

113 3/4"  
(2889 mm)

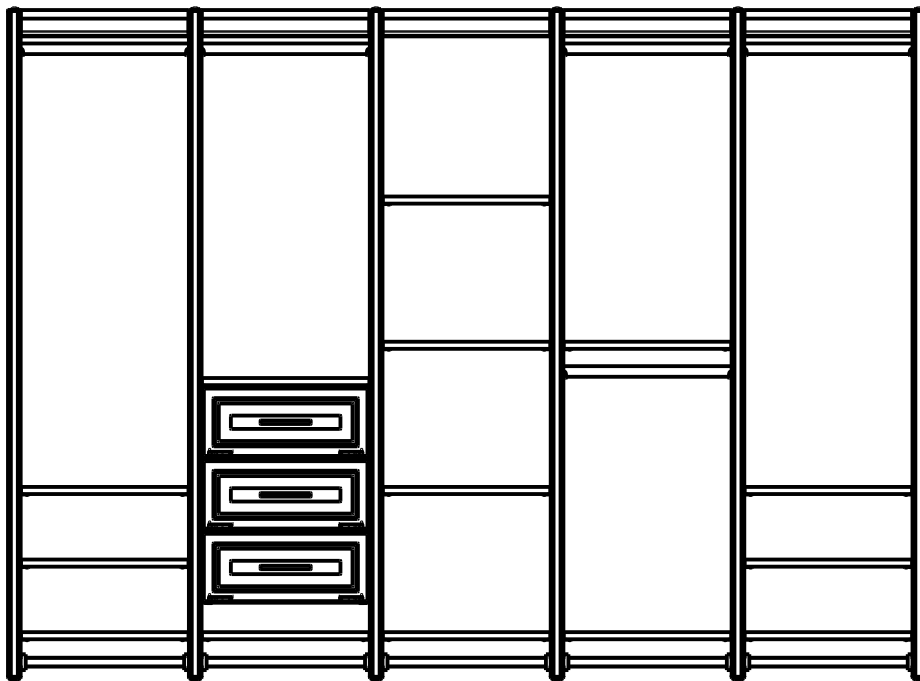

16 3/4"  
(425 mm)

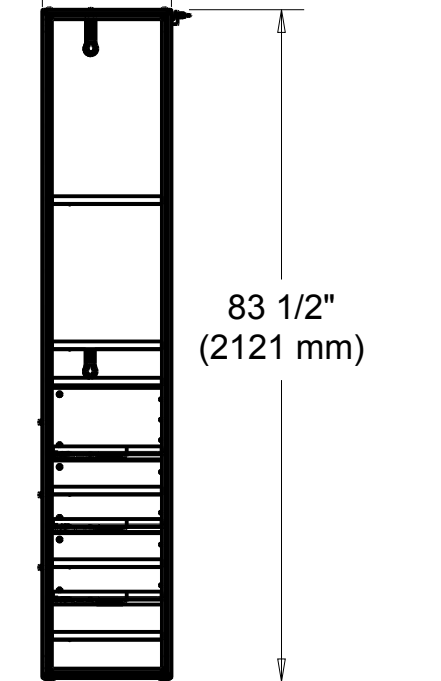

83 1/2"  
(2121 mm)

CLOSETS  
By LIBERTY

# 10ft Closet System

## ALUMINUM VERTICAL KITS

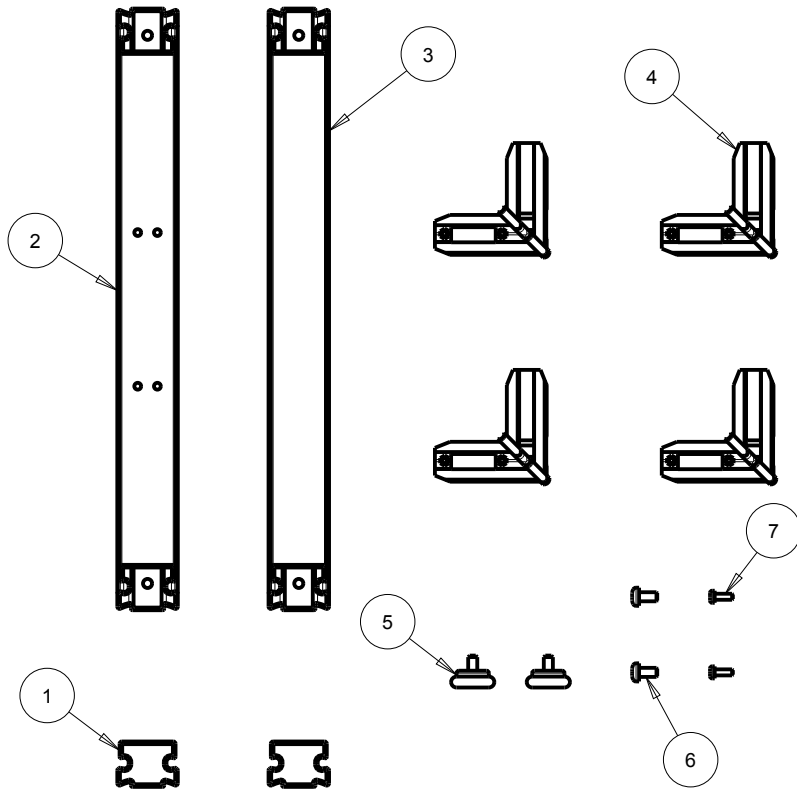
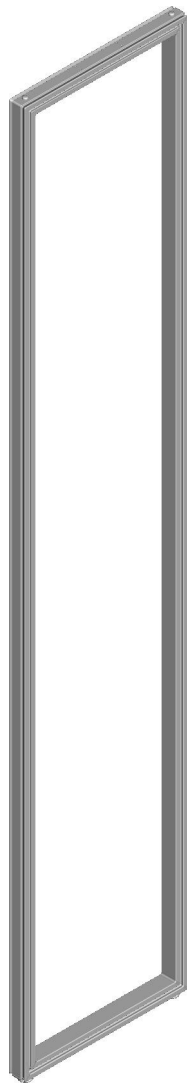

ID	DESCRIPTION	QTY
1	FULL HEIGHT VERTICAL EXTRUSION	2
2	HEADER MEMBER	1
3	HORIZONTAL MEMBER	1
4	COUPLER ASSEMBLY	4
5	LEVELING FEET	2
6	M6 X 12.0 PHILLIPS PAN HEAD MACHINE SCREW	2
7	M4 X 12.0 PHILLIPS PAN HEAD MACHINE SCREW	2

**QTY:** 6

**MATERIALS:** Powder Coated Aluminum Frame and Glass Filled Nylon Corners

**DIMENSIONS:** Assembled closet organization system is 113-3/4 in. wide x 16-3/4 in. deep x 83.5 in. tall.

**INSTALLATION:** Detailed Instructions and Hardware Included for Easy Installation.

**UNIQUE FEATURE:** Smart customization with bracket locations every 4.5 in. to offer the maximum customizability and optimize space in the closet

**WARRANTY:** 1 Year Limited Warranty.



# 10ft Closet System

## THREE DRAWER KIT

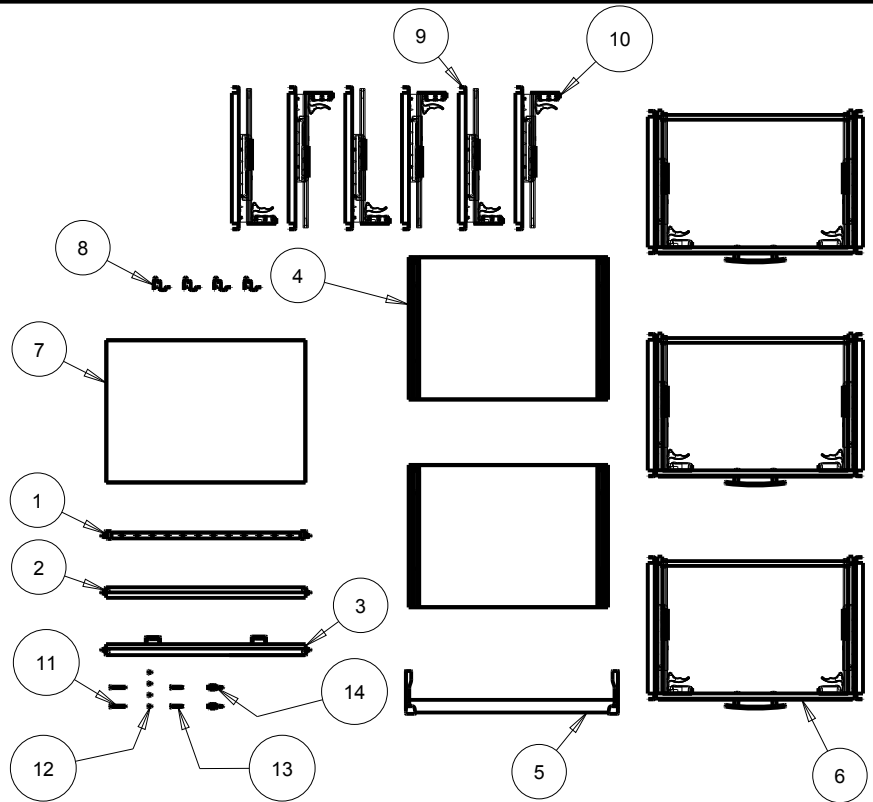
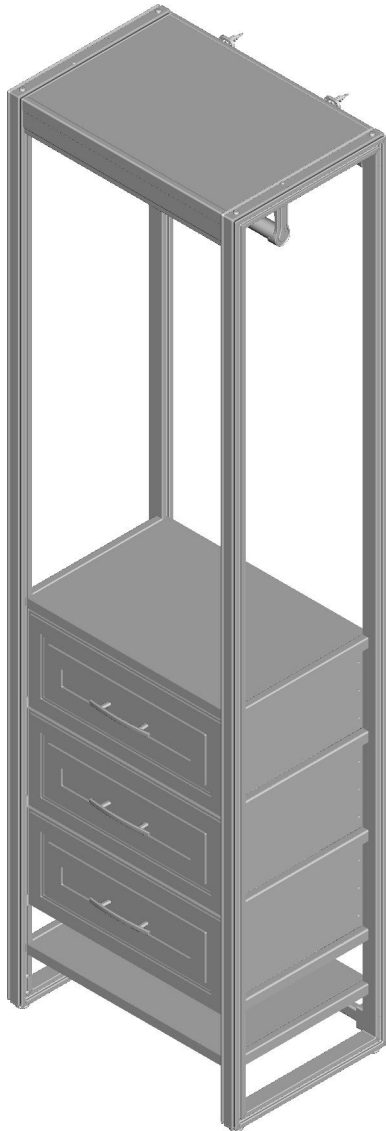

ID	DESCRIPTION	QTY
1	24IN REAR BOTTOM STABILIZER ASSEMBLY	1
2	24IN FRONT STABILIZER ASSEMBLY	1
3	24IN REAR TOP STABILIZER ASSEMBLY	1
4	24IN SHELF ASSEMBLY	2
5	24IN ROD ASSEMBLY	1
6	24IN DEEP DRAWER ASSEMBLY	3
7	24IN TOP SHELF ASSEMBLY	1
8	ACCESSORY BRACKET	4
9	LEFT SLIDE ASSEMBLY	3
10	RIGHT SLIDE ASSEMBLY	3
11	M4 X 40.0 FLAT HEAD TAPPING SCREW	2
12	M4 X 10.0 FLAT HEAD TAPPING SCREW	4
13	#8 X 1-1/4" PHILLIPS PAN HEAD TAPPING SCREW	2
14	AUGER ANCHORS	2

**QTY:** 1

**MATERIALS:** Engineered Wood drawer boxes with soft-close undermount slides. Aluminum hanging bars with Nylon brackets. Powder Coated Steel shelf supports. Engineered Wood shelves with Paper Coated Surface.

**DIMENSIONS:** Assembled closet organization system is 113-3/4 in. wide x 16-3/4 in. deep x 83.5 in. tall.

**INSTALLATION:** Detailed Instructions and Hardware Included for Easy Installation.

**UNIQUE FEATURE:** Drawer Pulls with a CTC measurement of 3-3/4 in. (96 mm) included in satin nickel finish to complement the timeless design of the closet system

**WARRANTY:** 1 Year Limited Warranty.



# 10ft Closet System

## TWO HANGING BAR KIT

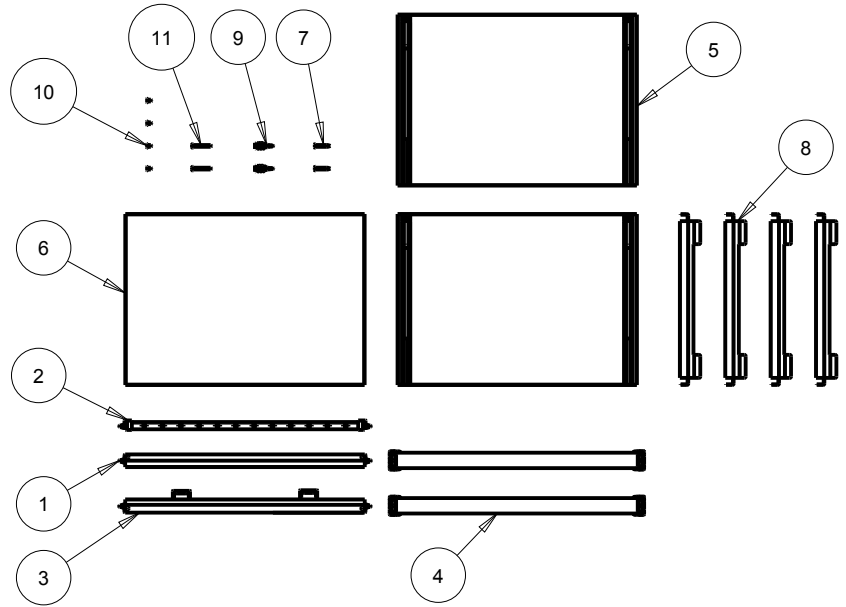
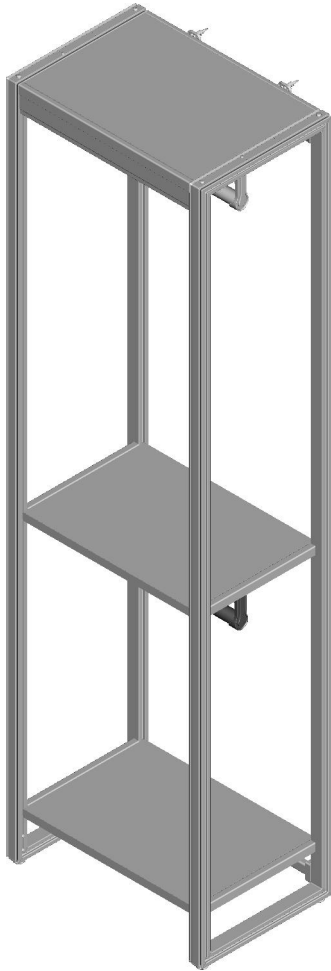

ID	DESCRIPTION	QTY
1	24IN FRONT STABILIZER ASSEMBLY	1
2	24IN REAR BOTTOM STABILIZER ASSEMBLY	1
3	24IN REAR TOP STABILIZER ASSEMBLY	1
4	24IN ROD ASSEMBLY	2
5	24IN SHELF ASSEMBLY	2
6	24IN TOP SHELF ASSEMBLY	1
7	#8 X 1-1/4" PHILLIPS PAN HEAD TAPPING SCREW	2
8	ACCESSORY BRACKET	4
9	AUGER ANCHORS	2
10	M4 X 10.0 FLAT HEAD TAPPING SCREW	4
11	M4 X 40.0 FLAT HEAD TAPPING SCREW	2

**QTY:** 1

**MATERIALS:** Aluminum hanging bars with Nylon brackets. Powder Coated Steel shelf supports. Engineered Wood shelves with Paper Coated Surface.

**DIMENSIONS:** Assembled closet organization system is 113-3/4 in. wide x 16-3/4 in. deep x 83.5 in. tall.

**INSTALLATION:** Detailed Instructions and Hardware Included for Easy Installation.

**UNIQUE FEATURE:** Need more storage? Our complementing accessories work within the closet system for an easy addition to help optimize your storage space.

**WARRANTY:** 1 Year Limited Warranty.



# 10ft Closet System

## FIVE SLIDING SHELF KIT

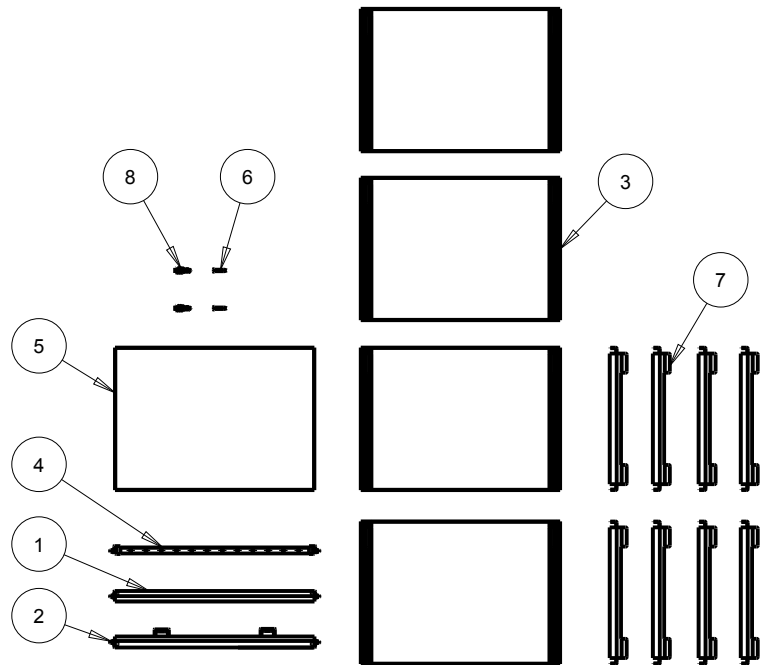
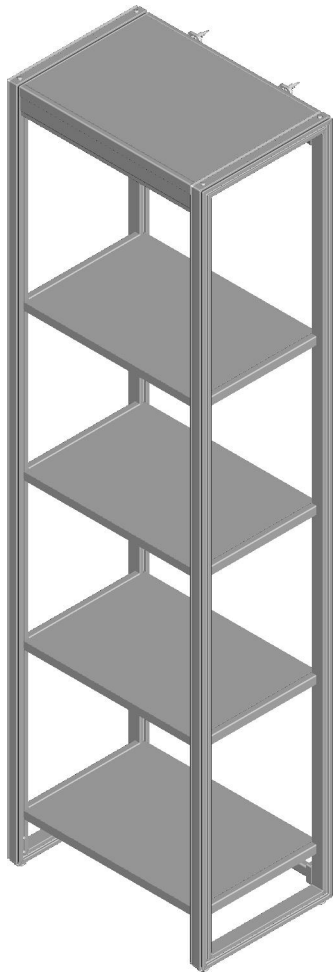

ID	DESCRIPTION	QTY
1	24IN FRONT STABILIZER ASSEMBLY	1
2	24IN REAR TOP STABILIZER ASSEMBLY	1
3	24IN SHELF ASSEMBLY	4
4	24IN REAR BOTTOM STABILIZER ASSEMBLY	1
5	24IN TOP SHELF ASSEMBLY	1
6	#8 X 1-1/4" PHILLIPS PAN HEAD TAPPING SCREW	2
7	ACCESSORY BRACKET	8
8	AUGER ANCHORS	2

- QTY:** 1
- MATERIALS:** Powder Coated Steel shelf supports. Engineered Wood shelves with Paper Coated Surface.
- DIMENSIONS:** Assembled closet organization system is 113-3/4 in. wide x 16-3/4 in. deep x 83.5 in. tall.
- INSTALLATION:** Detailed Instructions and Hardware Included for Easy Installation.
- UNIQUE FEATURE:** Dynamic customization allows you to move anything, anywhere at any time for the ultimate in customization in your closet.
- WARRANTY:** 1 Year Limited Warranty.



# 10ft Closet System

## FOUR SLIDE SHELF AND HANGING BAR KIT

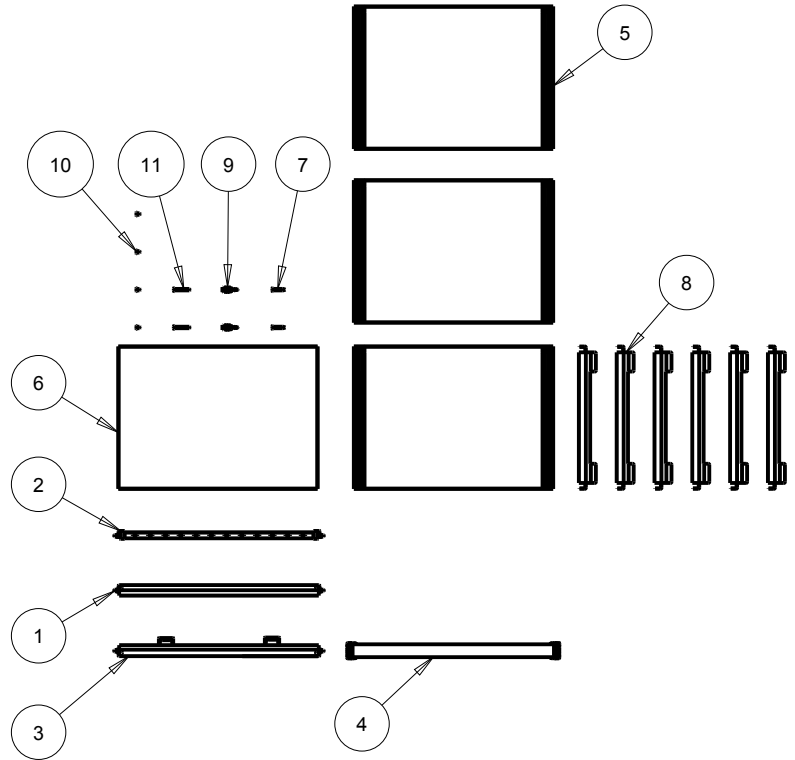
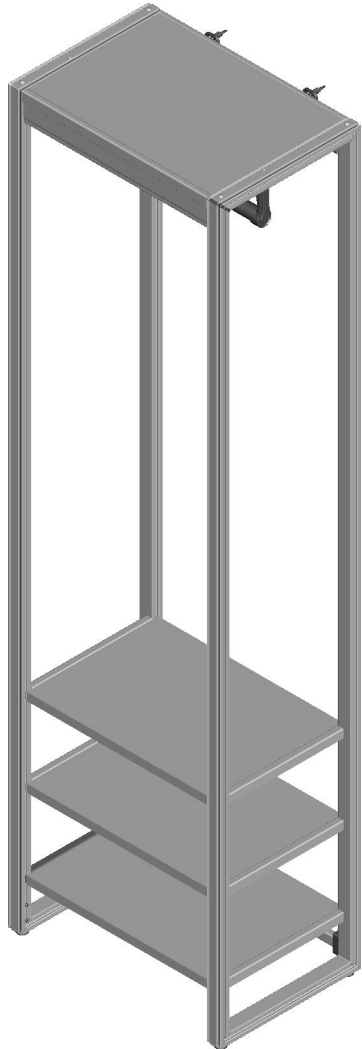

ID	DESCRIPTION	QTY
1	24IN FRONT STABILIZER ASSEMBLY	1
2	24IN REAR BOTTOM STABILIZER ASSEMBLY	1
3	24IN REAR TOP STABILIZER ASSEMBLY	1
4	24IN ROD ASSEMBLY	1
5	24IN SHELF ASSEMBLY	3
6	24IN TOP SHELF ASSEMBLY	1
7	#8 X 1-1/4" PHILLIPS PAN HEAD TAPPING SCREW	2
8	ACCESSORY BRACKET	6
9	AUGER ANCHORS	2
10	M4 X 10.0 FLAT HEAD TAPPING SCREW	4
11	M4 X 40.0 FLAT HEAD TAPPING SCREW	2

**QTY:** 2

**MATERIALS:** Aluminum hanging bars with Nylon brackets. Powder Coated Steel shelf supports. Engineered Wood shelves with Paper Coated Surface.

**DIMENSIONS:** Assembled closet organization system is 113-3/4 in. wide x 16-3/4 in. deep x 83.5 in. tall.

**INSTALLATION:** Detailed Instructions and Hardware Included for Easy Installation.

**UNIQUE FEATURE:** Allows for long hanging space and small item storage.

**WARRANTY:** 1 Year Limited Warranty.

