

SIMPLI™
HOME

Wyndent Hall™
HOME DECOR
brooklyn + max™

WARM SHAKER / NORFOLK / LEXINGTON

MEDIUM STORAGE & MEDIA CABINET

MODEL # AXWSH005-TB



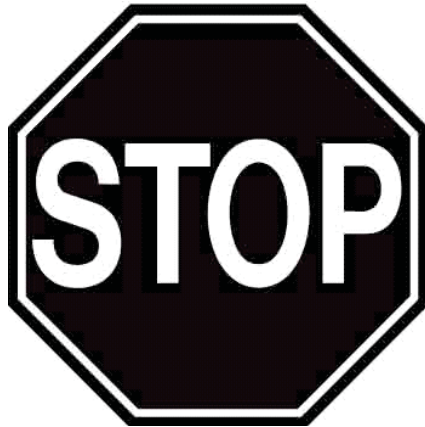

**FOR REPLACEMENT PARTS OR HELP WITH
ASSEMBLY PLEASE CONTACT US AT:**

simpli-home.com/customer-support

**PLEASE ENSURE TO HAVE THE MODEL #
FROM THE PACKAGING OR INSTRUCTION BOOKLET**

**TO RETURN THE PRODUCT:
PLEASE CONTACT THE RETAILER
WHERE THE ITEM WAS PURCHASED FROM**

SIMPLI[™]
H O M E

Wyndent Hall[™]
HOME DECOR
brooklyn + max[™]

**ENTER
TO WIN**

**Upload an image of our furniture
in your home with a short review
to our facebook page for a chance to**

**Win up to \$3000 of
Simpli Home furniture!!!**

www.facebook.com/simplihomefurnishings



IMPORTANT : Please read this manual carefully before beginning assembly of this product. Keep this manual for future reference.

SAFETY INFORMATION

Identify all the parts and hardware. Do not discard of the packaging until you have checked that you have all of the parts and hardware required. Hardware package may have spare parts.

WARNING: This item contains small parts which can be swallowed by children and pets. Keep children and pets away during assembly. To avoid danger of suffocation, always keep plastic bags away from children and pets. We recommend that you assemble this unit on a carpeted floor to avoid scratches. If using power tools, set the tool to low torque to avoid damage.

May require 2 people for ease of assembly.

CARE and MAINTENANCE

To clean, use a soft or slightly damp cloth, then wipe with a clean, dry cloth. Dust with soft dry cloth.

Do not use ammonia-based cleaning products, as they will damage the finish.

Do not leave liquids or damp cloths on this furniture.

To avoid dulling of the finish, do not place furniture in direct sunlight.

Please inspect and tighten all screws or bolts on a regular basis to ensure proper performance and safety of your item.

PARTS DESCRIPTION

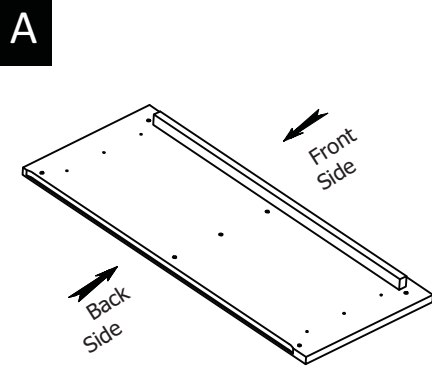

TOP
QTY 1

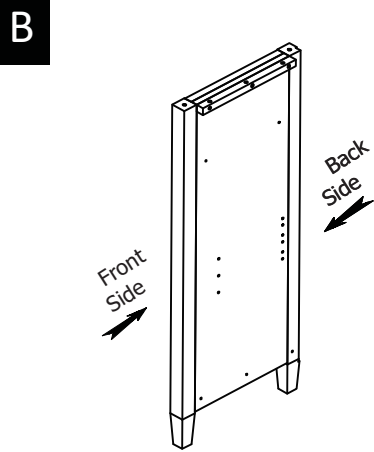

SIDE
QTY 1 PAIR

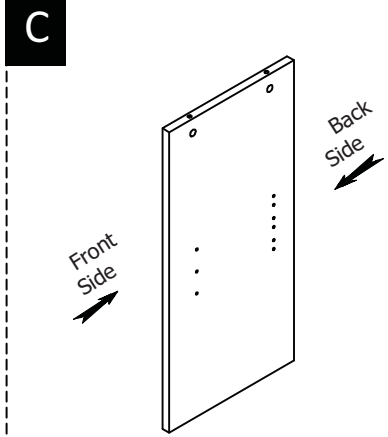

CENTRE SUPPORT
QTY 1

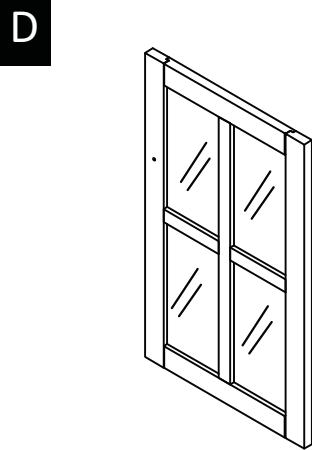

DOOR
QTY 1 PAIR

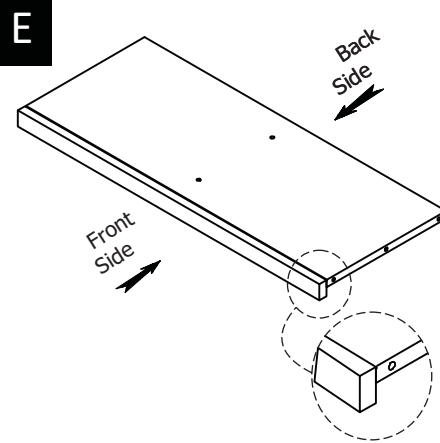

BOTTOM SHELF
QTY 1

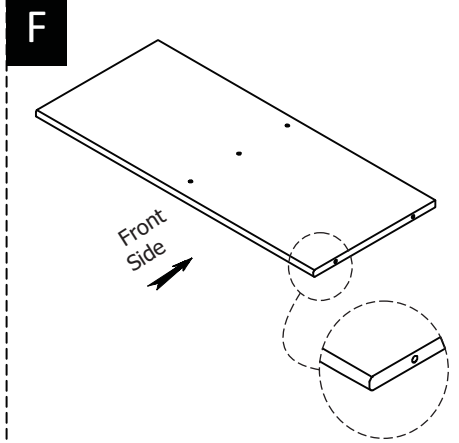

TOP SHELF
QTY 1

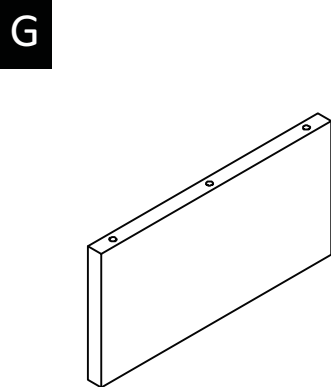

DIVIDER
QTY 1

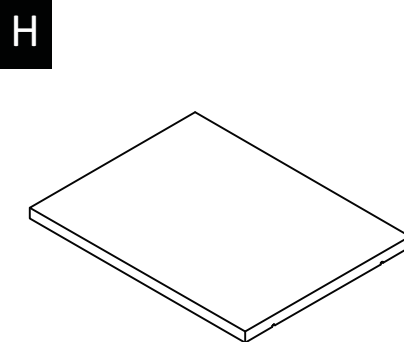

CABINET SHELF
QTY 2

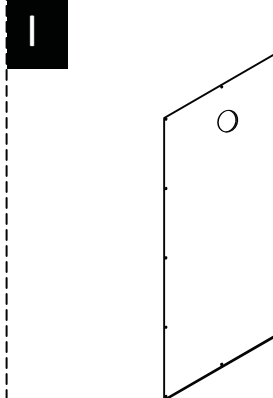

BACK PANEL
QTY 2

NEED HELP? For help with assembly or if you are missing a part,
Please call customer service at 1-866-518-0120 ext. 262 (9 am to 4 pm EST)

HARDWARE DESCRIPTION

1

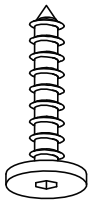

ALLEN KEY SCREW
M6 X 30 mm
QTY 8

2

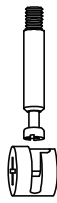

CAM LOCK PIN
CAM LOCK
QTY 12 SETS

3

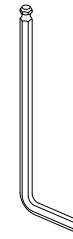

ALLEN KEY
QTY 1

4

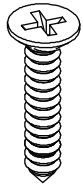

PHILLIPS SCREW
M4 X 15 mm
QTY 24

5

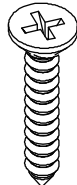

PHILLIPS SCREW
M3 X 15 mm
QTY 8

6

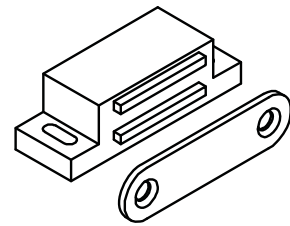

MAGNET AND PLATE
QTY 2 SETS

7

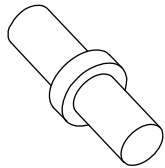

SHELF SUPPORT
QTY 12

8

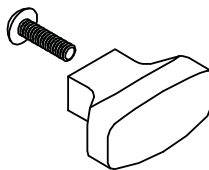

HANDLE
M4 X 25 mm
QTY 2 SETS

9

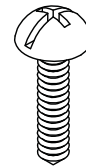

PHILLIPS SCREW
ROUND HEAD
M4 X 15 mm
QTY 21

10



- a. M4 x 25mm - QTY 1
- b. M4 x 15mm - QTY 1
- c. M4 x 25mm - QTY 1

TIPPING RESTRAINT
QTY 1 SET

11



WOOD DOWEL
Ø8 X 30 mm
QTY 10

12

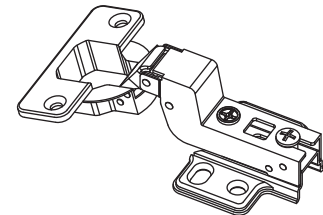

ADJUSTABLE HINGE
QTY 4 SETS

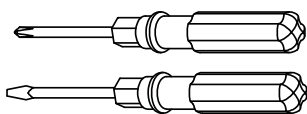

Required -
Flathead screwdriver
Phillips screwdriver
Rubber mallet
Not Included

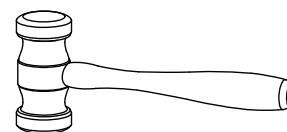

NEED HELP? For help with assembly or if you are missing a part,
Please call customer service at 1-866-518-0120 ext. 262 (9 am to 4 pm EST)

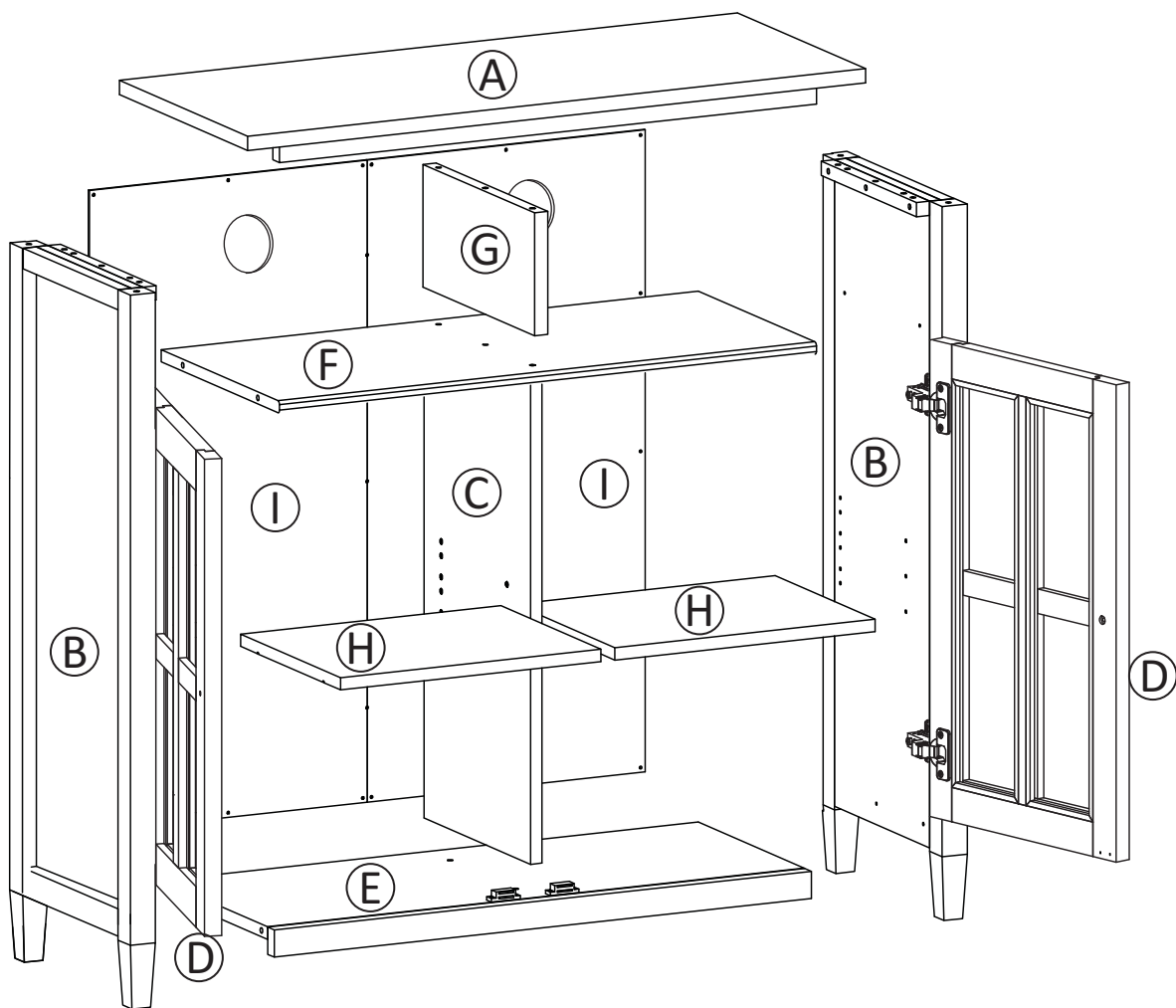

STEP 1

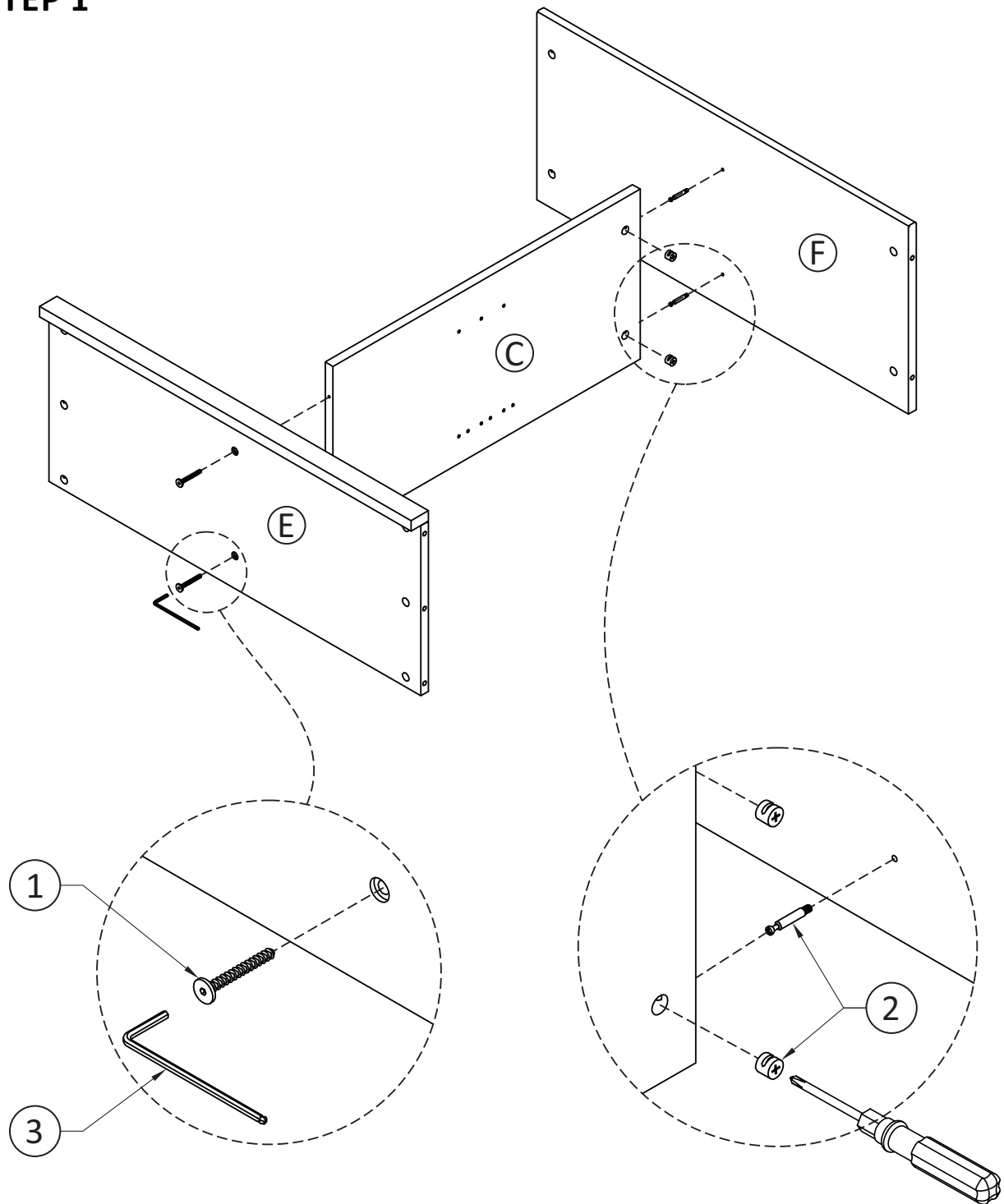

1. Attach Bottom Shelf (E) to Centre Support (C) with Allen Key Screws (1) through pre-drilled holes.
2. Attach Cam Lock Pins (2) to Top Shelf (F) using guide holes.
3. Align Cam Lock Pins (2) and insert into pre-drilled holes on Centre Support (C).
4. Insert 2 Cam Locks (2) into pre-drilled holes in Centre Support (C).
5. Once in place tighten Cam Locks (2) using a flathead screwdriver.

STEP 2

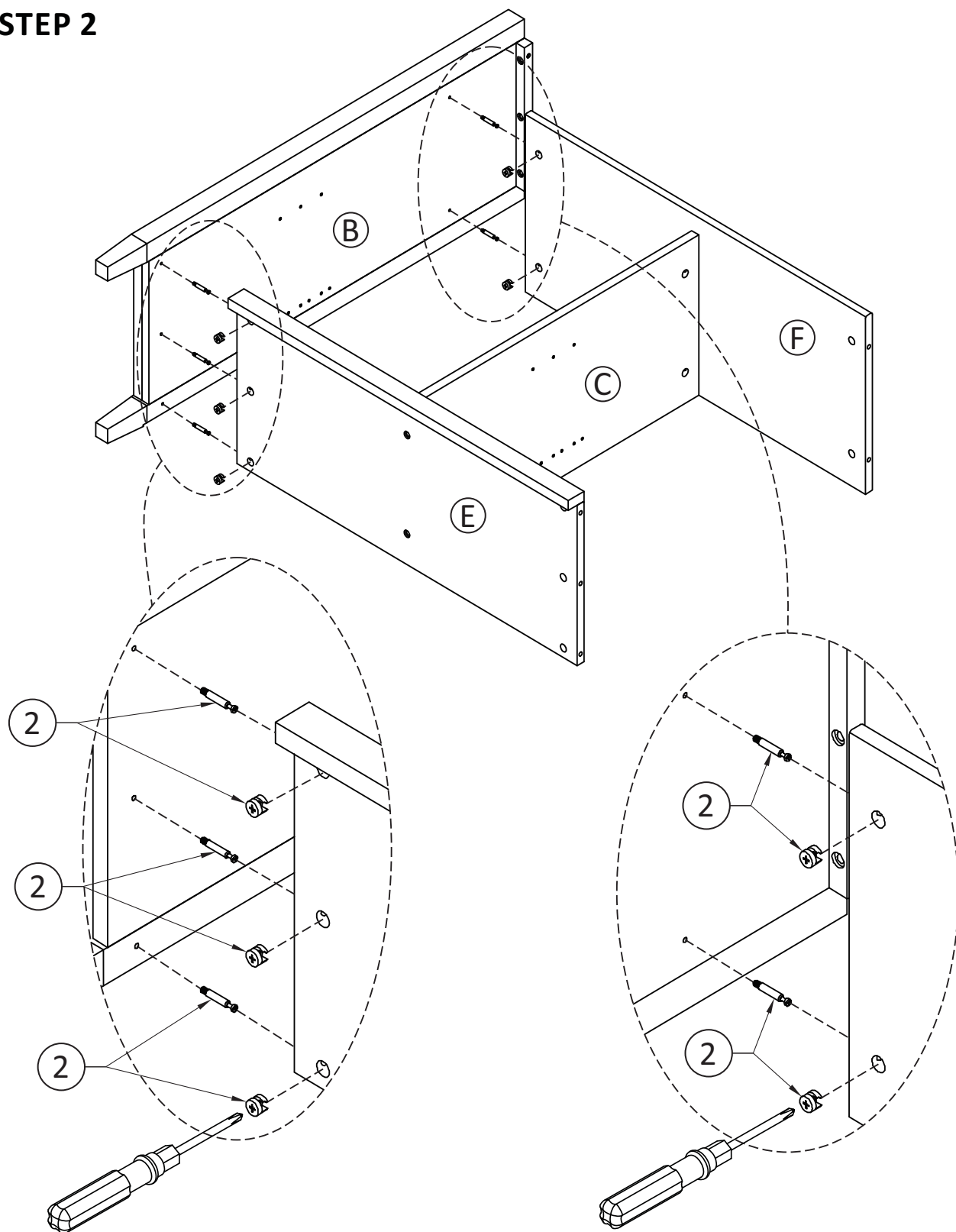

1. Attach Cam Lock Pins (2) into guide holes on Side (B) (3 Cam Lock Pins for the bottom and 2 for the top).
2. Align Cam Lock Pins (2) with pre-drilled holes of Bottom Shelf (E) and Top Shelf (F).
3. Insert Cam Locks (2) into pre-drilled holes of Bottom Shelf (E) and Top Shelf (F).
4. Once in place tighten Cam Locks (2) using a flathead screwdriver.

STEP 3

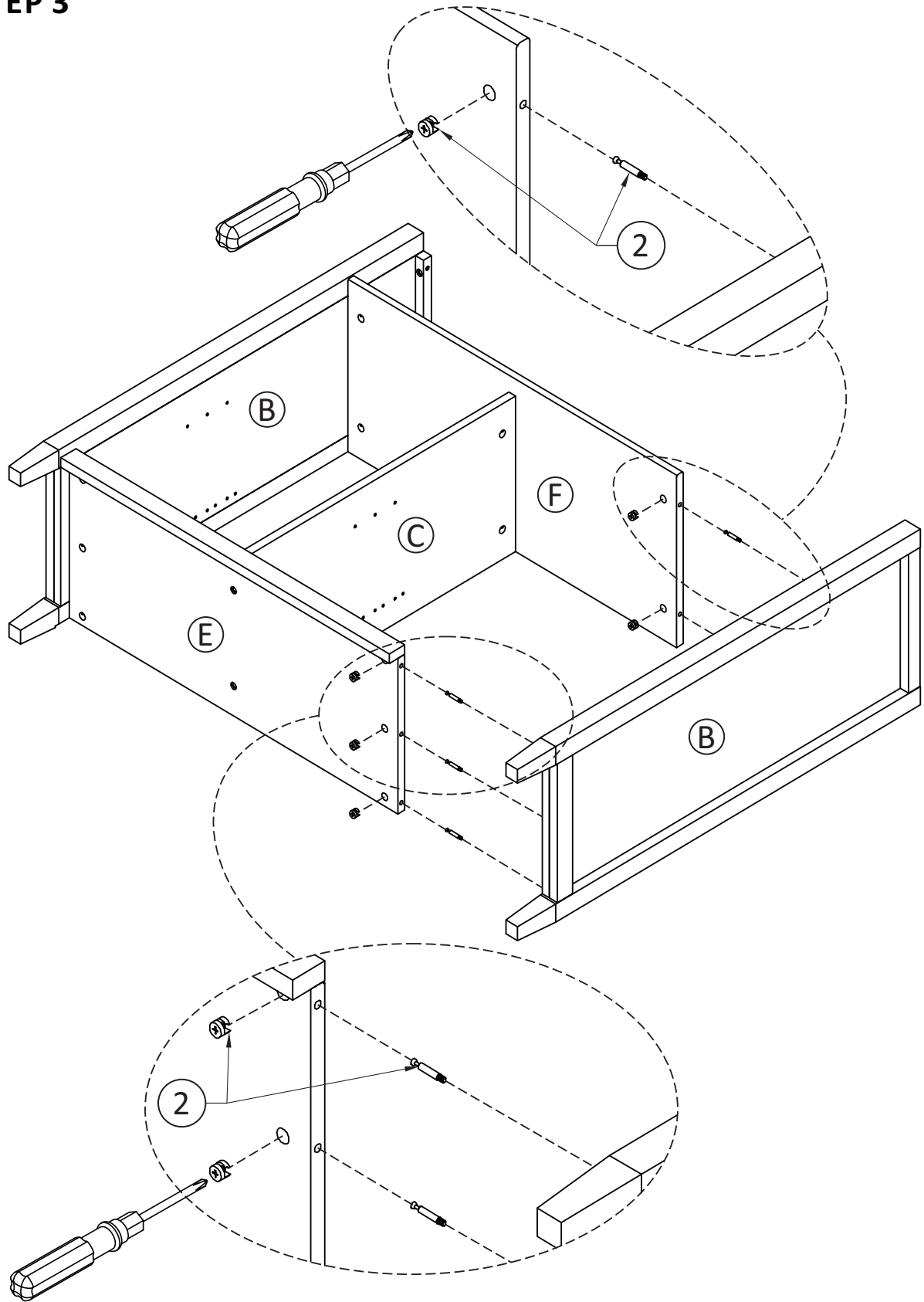

1. To attach opposite Side (B) to Bottom Shelf (E) and Top Shelf (F) repeat steps 1 - 4 in step 2.

STEP 4

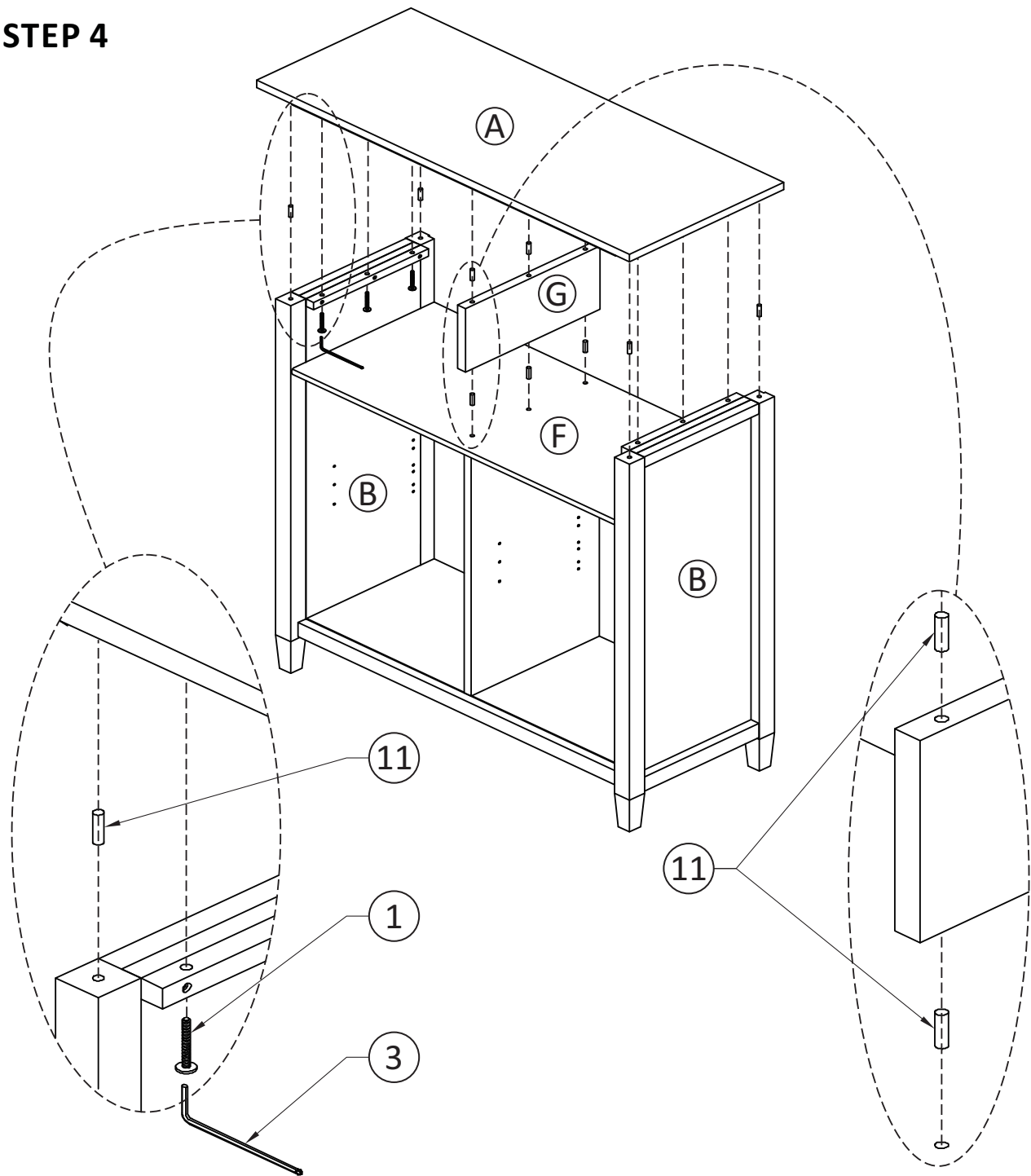

1. Insert 2 Wood dowels (11) into corner of each Side (B).
2. Insert 6 Wood dowels (11) into Divider (G).
3. Use rubber mallet to tap Dowels (11) into bottom of holes securely. $\frac{1}{2}$ length of Dowels should be exposed.
4. Align Dowels (11) with pre-drilled holes in centre of Top Shelf (F) and insert firmly.
5. Align pre-drilled holes on bottom of Top (A) with Dowels on Sides (B) and Top Centre (G).
6. Firmly insert Dowels (11) into part (A).
7. Attach Top (A) to Sides (B) through pre-drilled holes using Allen Key Screws (1).
8. Use Allen Key (3) to tighten screws.

STEP 5

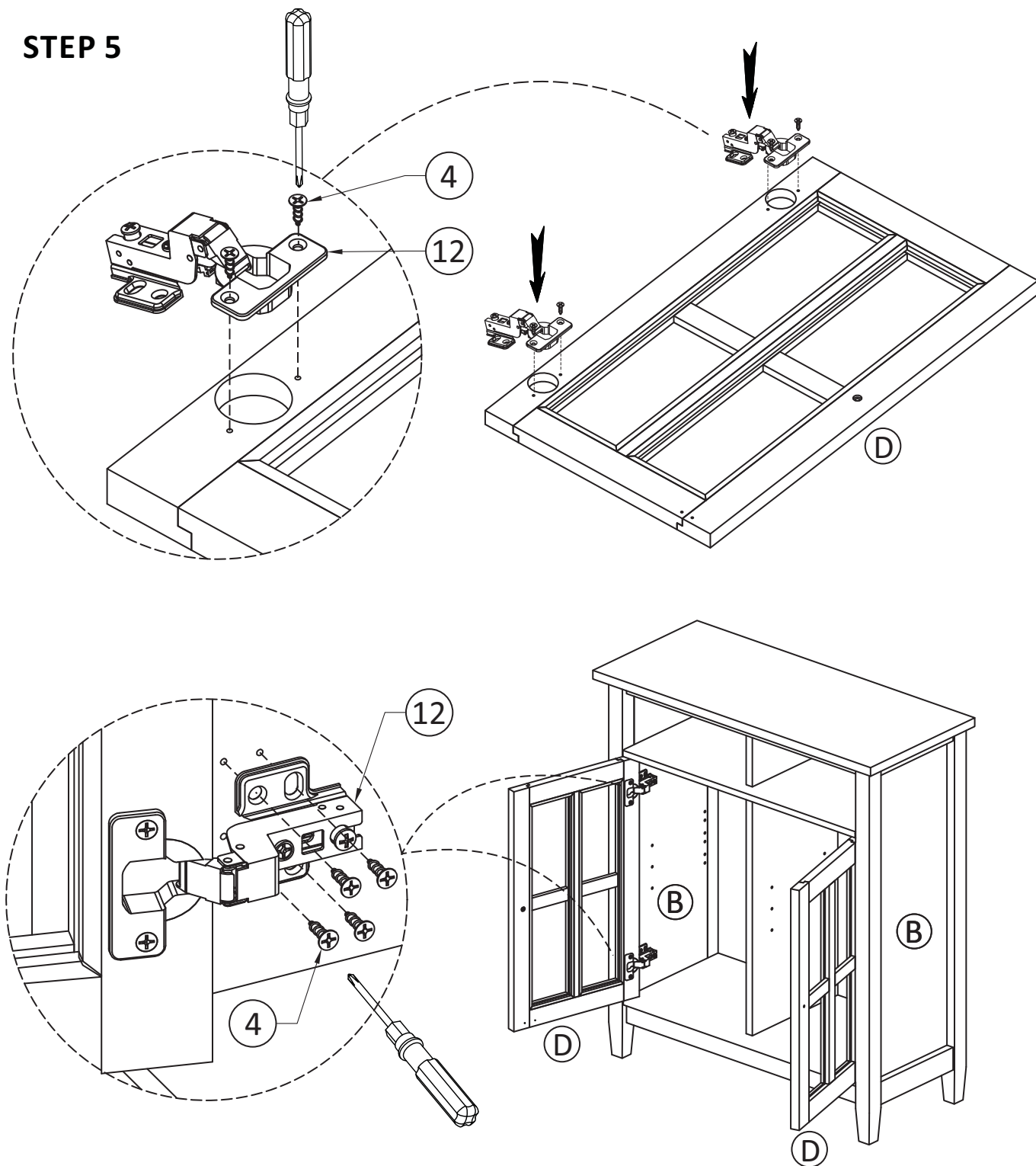

1. Attach Adjustable Hinges (12) to Doors (D) using Phillips Screws (4) into guide holes on Doors (D).
2. Attach Adjustable Hinges on Doors (D) to Sides (B) using Phillips Screws (4) into guide holes on Sides (B).
3. Use a Phillips screwdriver to tighten screws.

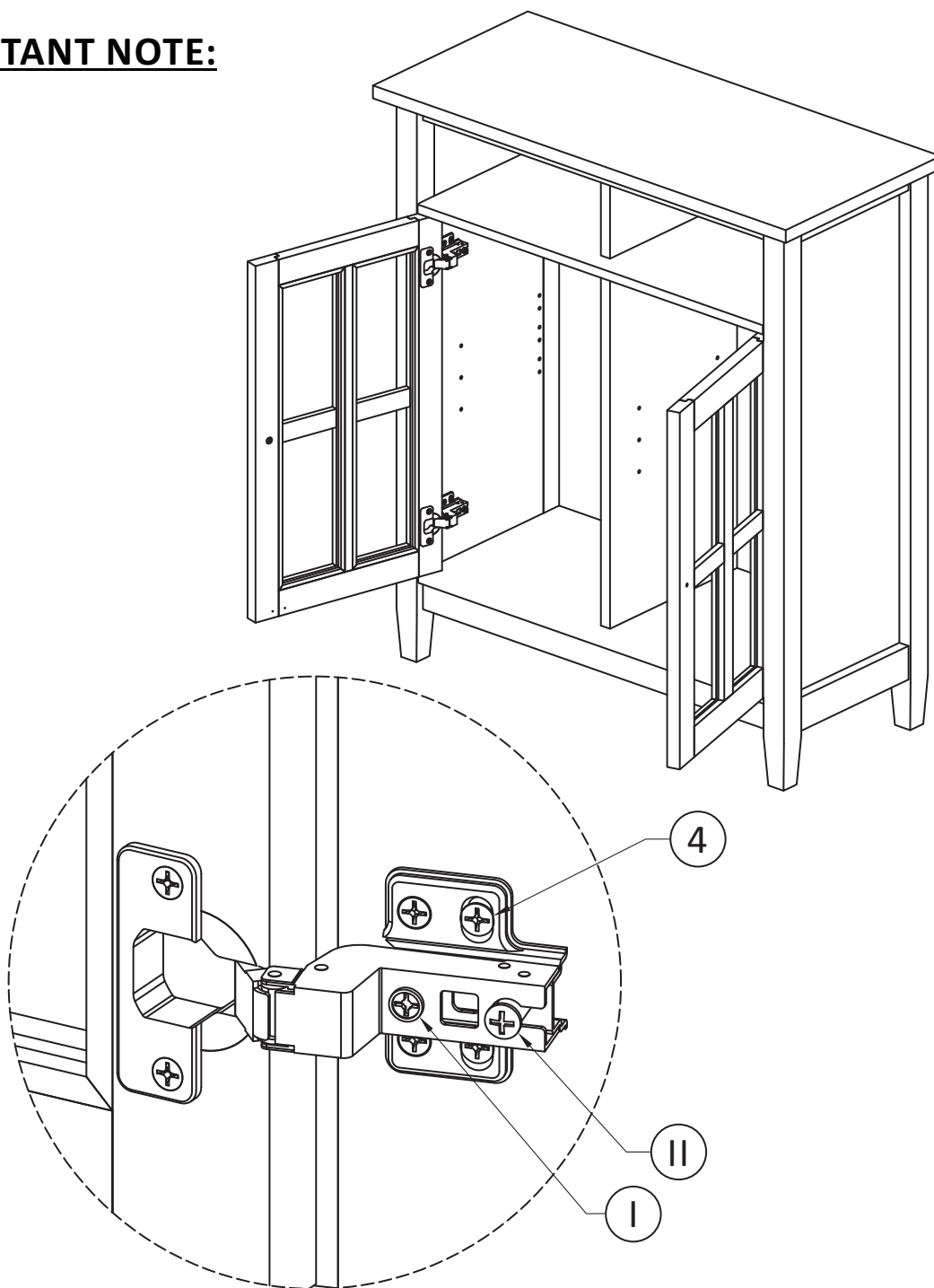
IMPORTANT NOTE:

Tighten the Screw marked (II) to fasten hinge. The door may need to be adjusted so that all the spaces between the door and the unit sides are equal. To adjust, follow instructions:

1. Side adjustment 4 mm

To move the door towards the side panel, loosen screw (I) and tighten screw (II) .

To move the door away from the side panel, loosen screw (II) and tighten screw (I) .

2. Depth adjustment 4 mm

Loosen screw (II) (just one turn), adjust door to desired position, re-tighten screw .

3. Height adjustment

Loosen screw (4) , adjust door to desired position, re-tighten screw .

STEP 6

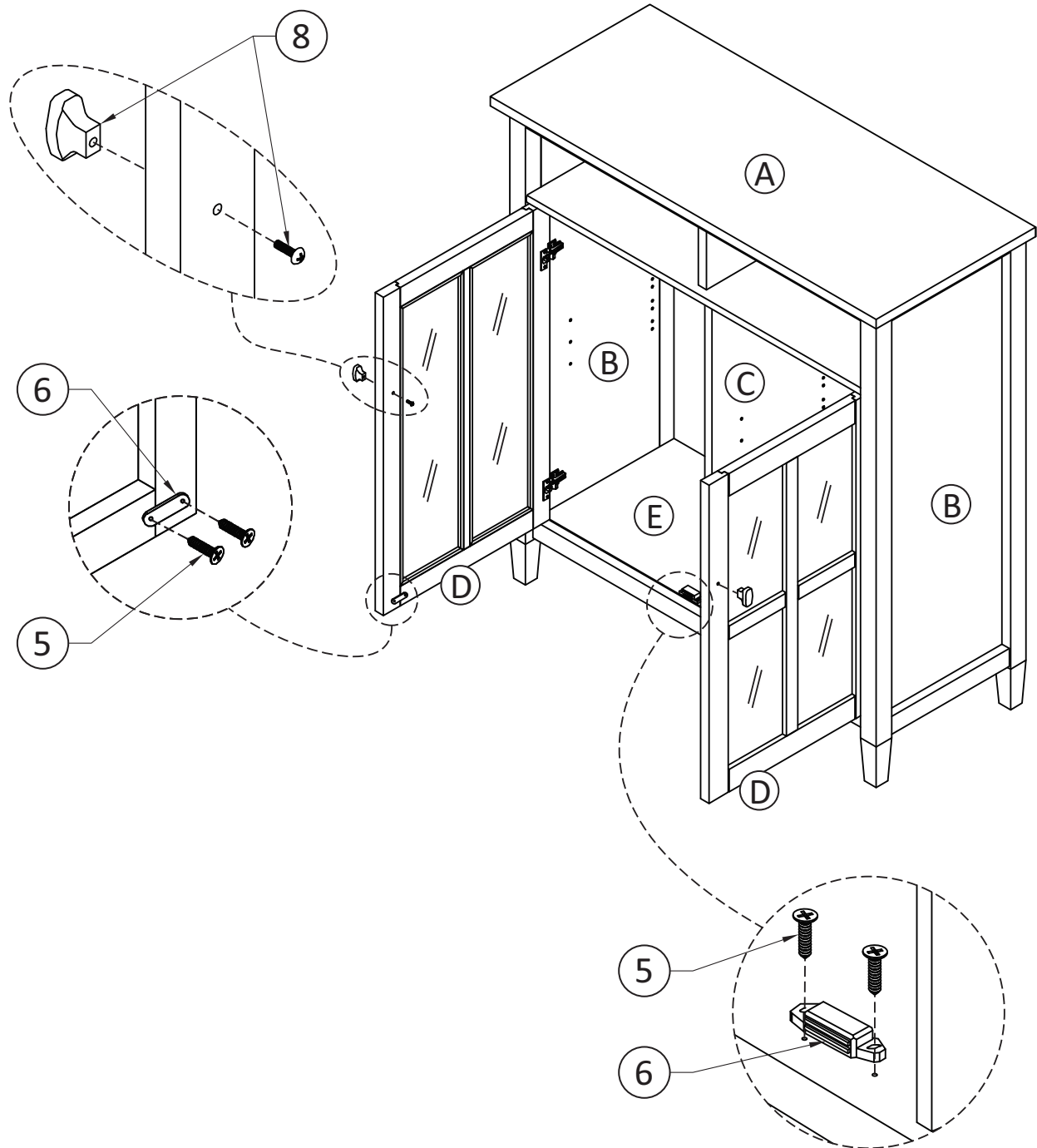

1. Attach Magnet Plates (6) to inside corners of Doors (D) using Phillips Screws (5) into guide holes on Doors (D).
2. Attach Magnet (6) to inside corner of Bottom Shelf (E) using Phillips Screws (5) into guide holes on Bottom Shelf (E).
3. Use a Phillips screwdriver to attach Handles (8) to Doors (D).

STEP 7

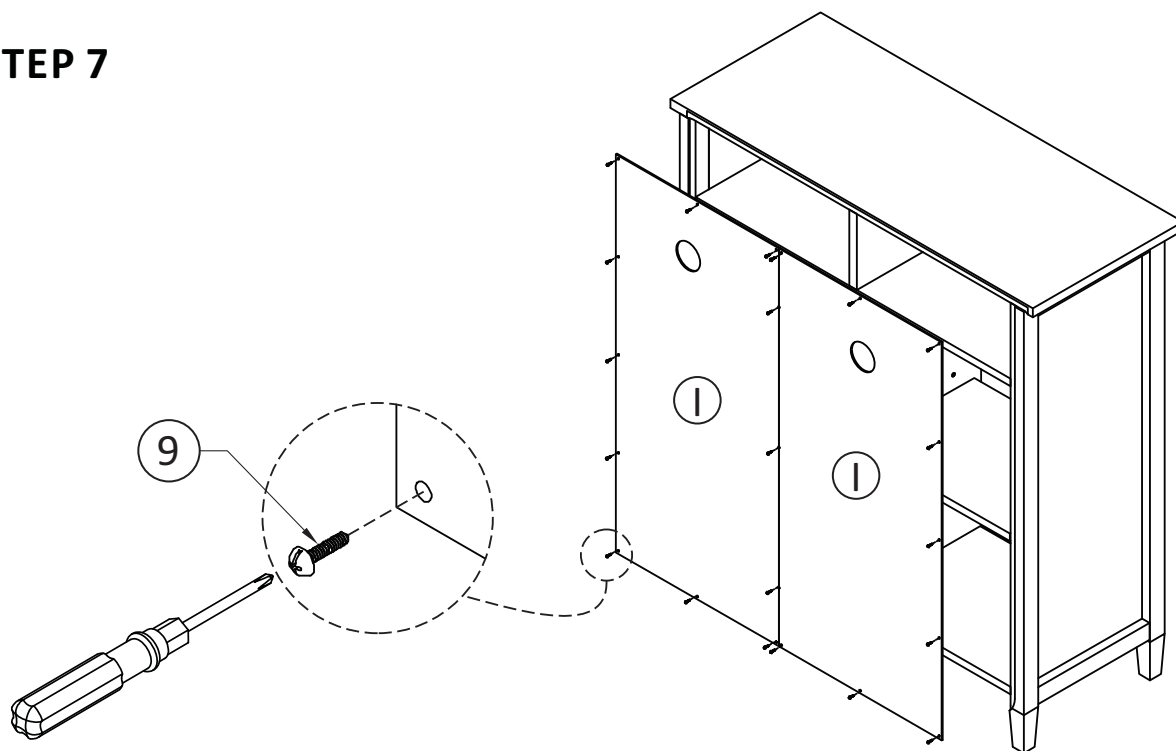

1. Attach Back Panels ① to back of cabinet using Phillips Screws Round Head ⑨ into pre-drilled guide holes.
2. Use Phillips screwdriver to tighten screws.

STEP 8

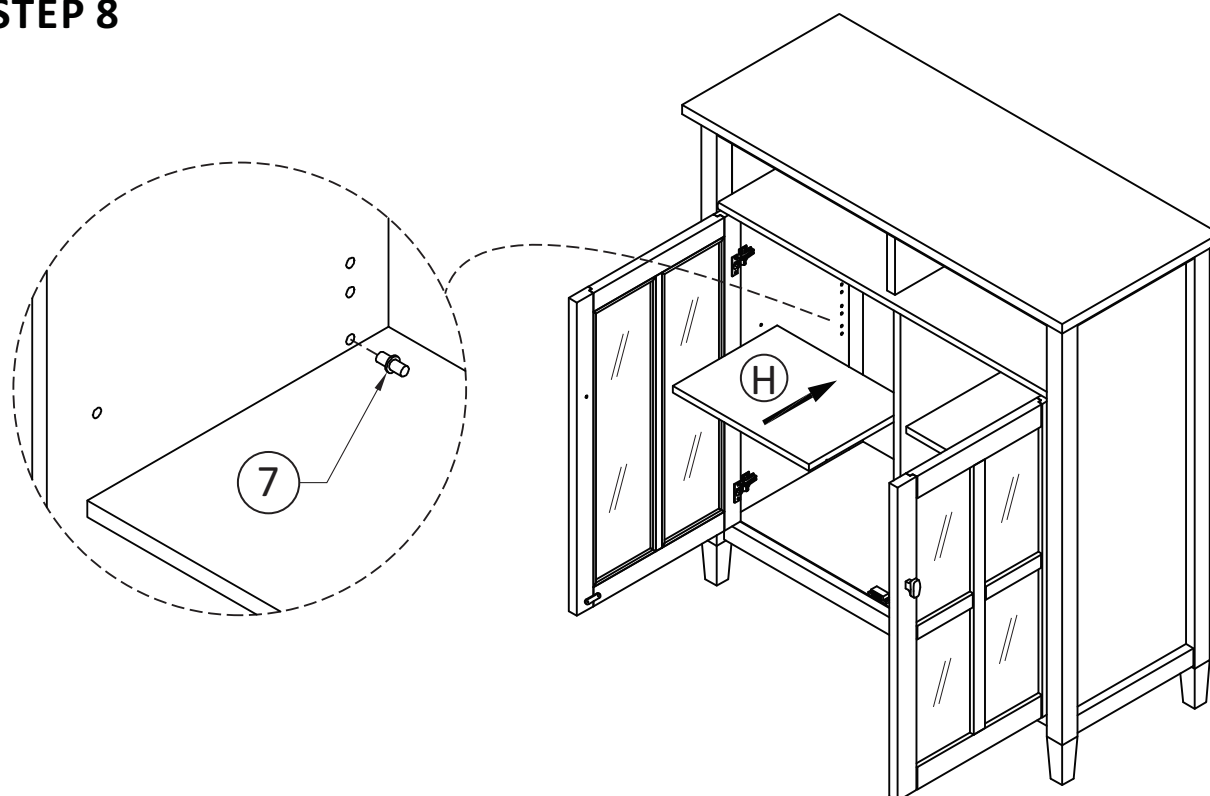

1. Use 4 Shelf Supports ⑦ for each Cabinet Shelf ⑧ in desired location.
2. 2 Shelf Supports ⑦ may be used on back top of each Cabinet Shelf ⑧ as a tipping restraint.

NOTE: Injuries and damage can occur from furniture tip-over. It is important to use the safety bracket included. If the tipping restraint kit is not in the box, please contact our customer service department in order to obtain another kit before using the furniture.

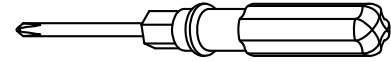
STEP 9

NOTE: The screwdriver is not included in the hardware pack.

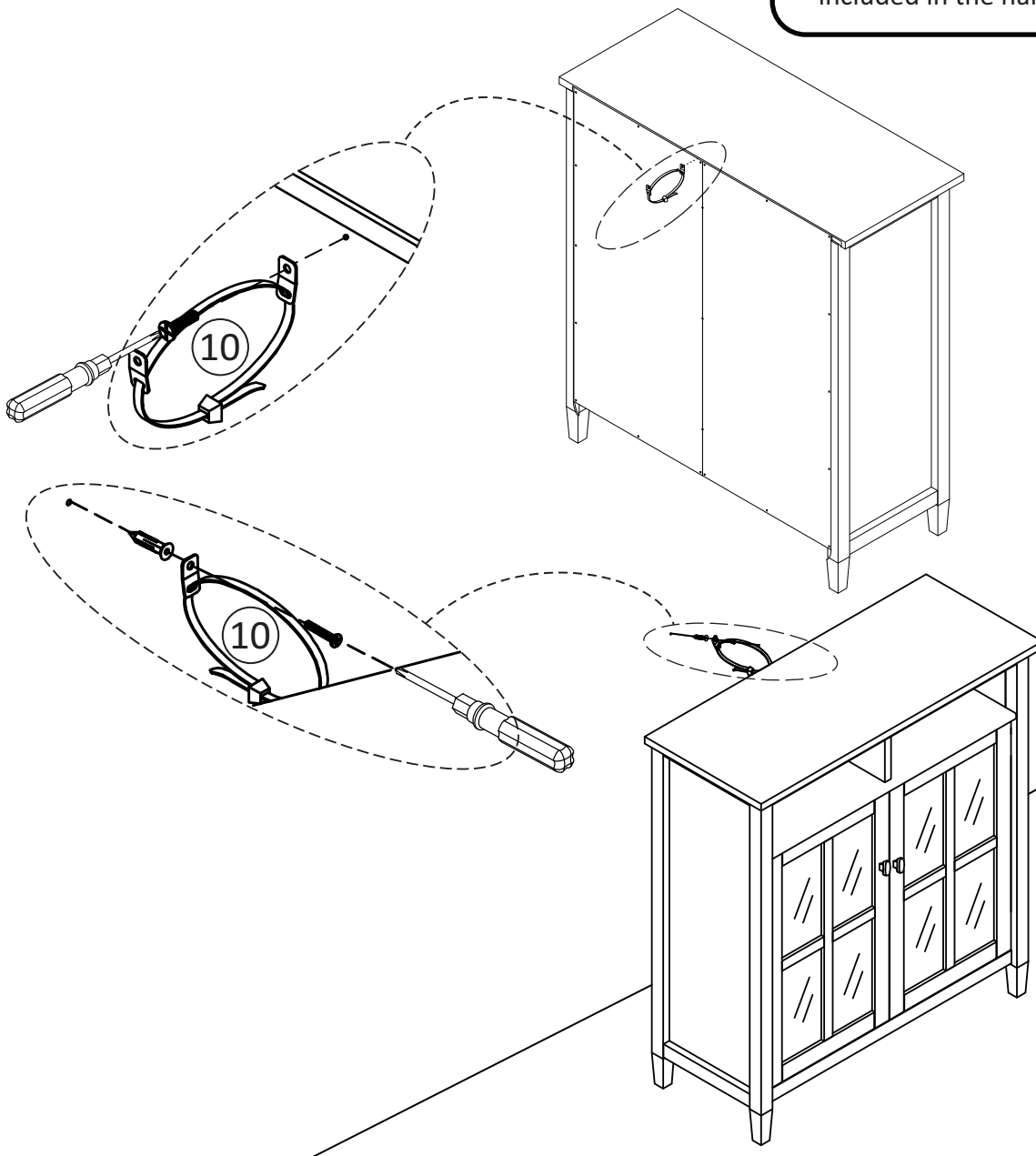

1. To attach Tipping Restraint ⑩, follow instructions on Tipping Restraint package.

When you determined the location for your unit, install the Furniture Tipping restraint. Carefully follow the instructions contained on the package.



WARRANTY

Thank you for purchasing a **Simpli Home – Wyndenhall – Brooklyn + Max** product. These products have been made to demanding, high-quality standards and are guaranteed for domestic use against manufacturing faults for a period of 12 months from the date of purchase. This warranty does not affect your statutory rights.

In case of any malfunction of your product (failure, missing parts, etc.) please contact us at our toll free service line at 1-866-518-0120 ext. 262 from 9 am to 4 pm, Monday to Friday, Eastern Standard Time or by email at simpli-home.com/customer-support.

We reserve the right to repair or replace the defective product, at its discretion.

This product is guaranteed for 12 months if used for normal purposes. Any warranty is invalid if the product has been overloaded or subject to neglect, improper use or an attempted repair by other than an authorized agent. Heavy-duty or daily professional/commercial usage are not guaranteed.

Due to continuous product improvement, we reserve the right to change the product specifications without prior notice.



Question, problems, missing parts?

Before returning your product
please email Customer Support at
simpli-home.com/customer-support

or call

Customer Support at 1-866-518-0120 ext. 262
Monday to Friday between 9 am – 4 pm EST

For more information visit us on our website
www.simpli-home.com

Like us on facebook
www.facebook.com/simplihomefurnishings