



4" Ceramic Tile Wet Saw



Features & Benefits:

- 1/4HP, 3,600 RPM motor
- Capable of performing square, angled, and diagonal cuts
- Table tilts up to 15°, 30°, and 45° for precision miter cuts
- Automatic thermal overload protection
- Lightweight and portable
- Accepts 4" blade with standard 5/8" arbor
- Limited 1 year warranty
- UL listed

Includes:

- 4" continuous rim wet diamond blades
- 45° angle bar
- Rip guide



Specifications

Motor: 120V-60Hz
1/4HP

RPM: 3,600 (single speed)

AMPS: 1.5

Blade capacity: 4" (102mm)

Arbor: 5/8" (16mm)

Size: 13 1/16"W x 14"D x 3 5/8"H
(total height)

Weight: 8 lbs.

Length of Cut: Unlimited



STK#	Description	Quantity	Packaging
60084A	4" Ceramic Tile Wet Saw	1	Box





4" Ceramic Tile Wet Saw

PARTS LIST

DESCRIPTION	SKT#
Rip Guide	60084A-01
Wing Nut	60084A-02
Washer	60084A-03
Blade Guard	60084A-04
Screw for Wing Nut (Guard)	60084A-05
Guard Support	60084A-06
Wing Nut	60084A-07
Outer Washer	60084A-08
Inner Washer	60084A-10
Miter Support	60084A-11
Right Cutting Table	60084A-12
Screw for Cutting Table (7)	60084A-13
Left Cutting Table	60084A-14
Capacitor	60084A-15
Motor	60084A-16
Frame	60084A-17
Switch	60084A-18
Screw for Motor (2)	60084A-19
Rubber Stand (4)	60084A-20
Electrical Cord	60084A-21
45° Angle Cutting Guide	60084A-22
4" Continuous Rim Wet Blade	6-4000CR

EXPLODED PARTS

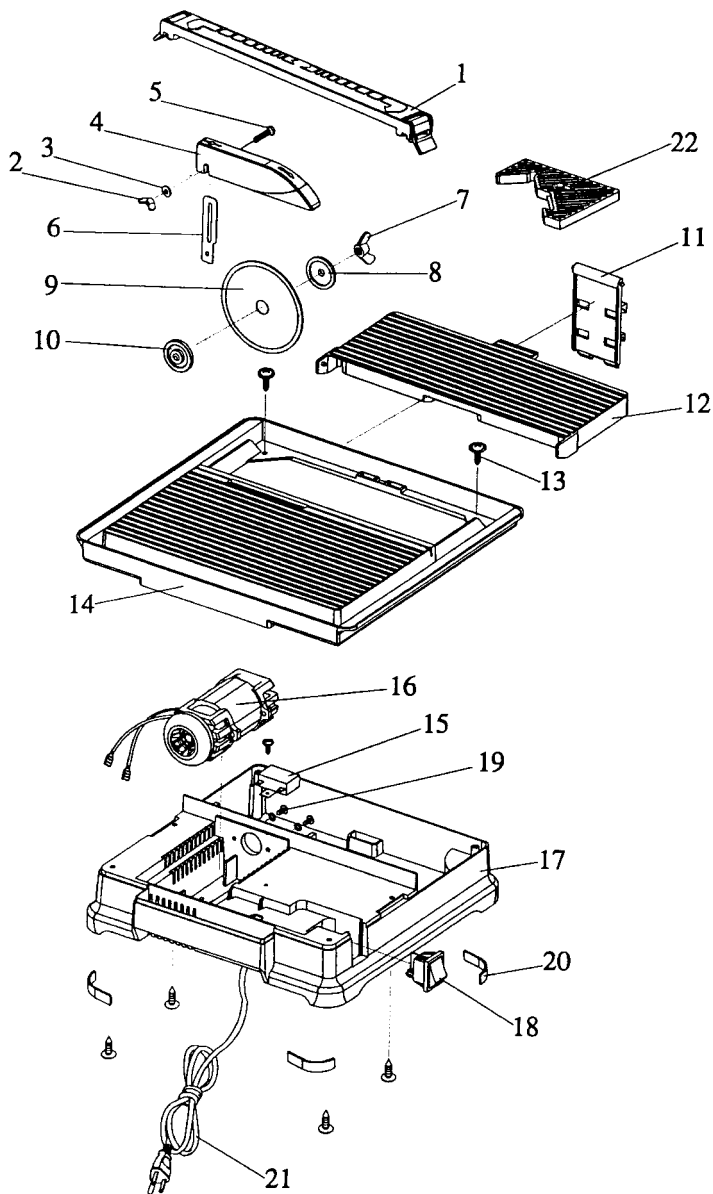

QEP is proud to introduce the new 60084A 4" Ceramic Wet Tile Saw. Great for home projects, kitchen and bathroom renovation, countertops/tabletops, window sills/thresholds and mosaics. Lightweight and portable, this saw is a great home improvement tool for small remodeling jobs.

Q.E.P. Co., Inc. • Boca Raton, FL 33487 • (800) 777 8665 • www.qep.com



Roberts Company Canada Ltd.
PH: (800) 840 9422

Roberts Holland B.V.
PH: (31) 184 495757

Q.E.P. Australia Pty. Ltd.
PH: (61) 3 9799 7122

Q.E.P. Co., N.Z., Limited
PH: (64) 9 415 9700

Q.E.P. Chile Limitada
PH: 011 562 443 1282