

**PRODUCT SPECIFICATIONS**

Elkay by Schock Premium Quartz 33" x 22" x 9-1/2" Double Bowl Dual Mount Sink. Sink is molded with natural quartz and high-performance UV-stable acrylic resins that result in an impact-resistant, nonporous and heat-, scratch-, stain- and fade-resistant surface. Naturally sound deadening and Rear Center drain placement.

<b>Installation Type:</b>	Top Mount
<b>Material:</b>	Quartz
<b>Finish:</b>	Gray (GRY)
<b>Number of Bowls:</b>	2
<b>Sink Dimensions:</b>	33" x 22" x 9-1/2"
<b>Bowl 1 Dimensions:</b>	14-9/16" x 18-3/16" x 9-1/2"
<b>Bowl 2 Dimensions:</b>	14-9/16" x 18-3/16" x 9-1/2"
<b>Drain Size:</b>	3-1/2" (89mm)
<b>Drain Location:</b>	Rear Center
<b>Minimum Cabinet Size:</b>	36"
<b>Mounting Hardware:</b>	Part # 64090408 included for countertops up to 1-3/4" (44mm) thick
<b>Cutout Template #:</b>	<a href="#">0000001442</a> <a href="#">1000003714</a>

Template is available for download at [elkay.com](http://elkay.com)

**Installation Profile:**

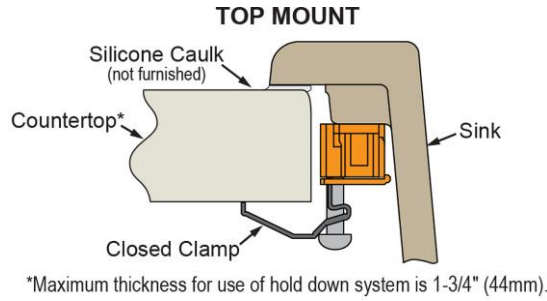

**OPTIONAL ACCESSORIES**

<b>Drain:</b>	LK99
<b>Rinsing Basket:</b>	LKWRB1518SS (large bowl), LKWERBSS (large bowl), LKWRB1516SS (small bowl)

PART: \_\_\_\_\_ QTY: \_\_\_\_\_  
 PROJECT: \_\_\_\_\_  
 CONTACT: \_\_\_\_\_  
 DATE: \_\_\_\_\_  
 NOTES: \_\_\_\_\_  
 APPROVAL: \_\_\_\_\_



AMERICAN PRIDE. A LIFETIME TRADITION. Like your family, the Elkay family has values and traditions that endure. For almost a century, Elkay has been a family-owned and operated company, providing thousands of jobs that support our families and communities.



Sinks are listed by IAPMO® as meeting the applicable requirements of the Uniform Plumbing Code®, International Plumbing Code®, and National Plumbing Code of Canada.

**Product Compliance:** CSA B45.5/IAPMO Z124

[Clean and Care Manual \(PDF\)](#)

[Installation Instructions \(PDF\)](#)

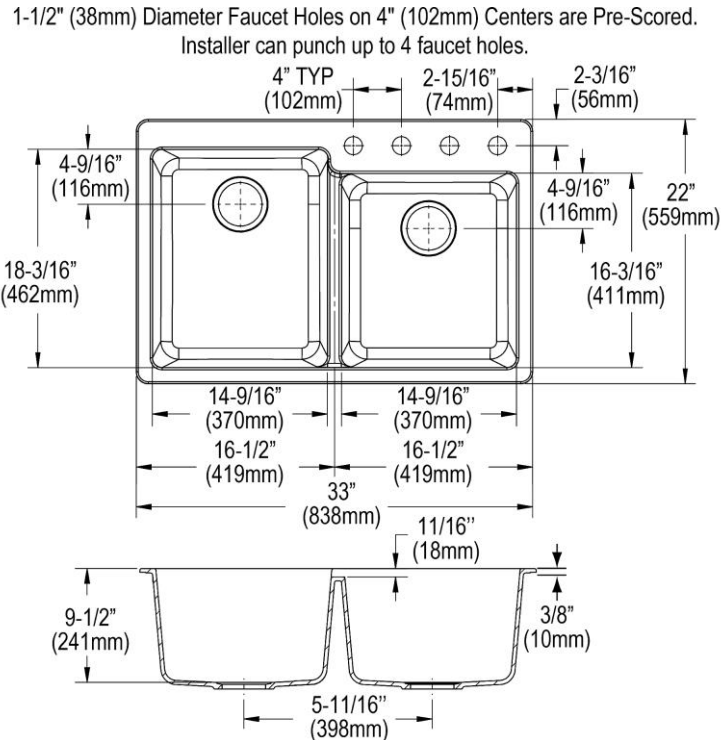

In keeping with our policy of continuing product improvement, Elkay reserves the right to change product specifications without notice. Please visit [elkay.com](http://elkay.com) for the most current version of Elkay product specification sheets. This specification describes an Elkay product with design, quality, and functional benefits to the user. When making a comparison of other producers' offerings, be certain these features are not overlooked.