

LONGEVITY[®]

The power to last!

www.longevity-inc.com



Operating Manual
for

***StickWeld*[®] 140 STL**

140 Amp Dual-Voltage PFC Lift TIG Optional STICK Welder

Table of Contents

Table of Content	Pg. 1
Thank you From LONGEVITY	Pg. 2
Warranty/Shipping Damage/Order Information	Pg. 3
Safety Information	Pg. 4-5
Specifications and Ratings	Pg. 6
What's Included?	Pg. 7
Main Unit Knob/Button/Function Diagram	Pg. 8
Troubleshooting	Pg. 13
Routine Maintenance	Pg. 16
Contact Info	Pg.17

THANK YOU!

We, at LONGEVITY, want to thank you for purchasing our product. You are almost ready to experience Longevity Welding first hand. Longevity definitely appreciates your business and understand that this equipment may be overwhelming to setup and operate so we have prepared a manual that will assist you in understand your new plasma cutter/welder. If you have any questions during or after reading this manual, please feel to contact us! Please take a moment to register your product on our website at www.longevity-inc.com or www.lweld.com

Once again, thank you for choosing Longevity as your main welding supplier!

Longevity Global, Inc
d
Hayward, CA 94545

Toll-Free Customer Support: 1-877-LONG-INC / 1-877-566-4462
Website: www.longevity-inc.com
Sales: sales@longevity-inc.com
Customer Service: help@longevity-inc.com
Dealers: dealers@longevity-inc.com
Complaints: complaints@longevity-inc.com

Please join our welding forums to share welding tips and tricks, to receive useful information from customers who also use our products, and to be a part of the Longevity™ welding community at www.freeweldingforum.com

Warranty

LONGEVITY Plasma Cutters, Welders, and Multi-Purpose Welders are covered for specific Parts and Labor warranty at our facility. For detailed information regarding your specific LONGEVITY welder or cutter, please view our Terms and Policies page on our website at the following website link: <http://www.longevity-inc.com/terms/>

Shipping Damage

Your machine is insured against damage during shipping. Keep all packing materials and containers in case machine must be returned. We will initiate a claim with the shipping company to cover damage or loss. If there is shipping damage upon opening your package, our customer service team will work with you to get the matter resolved.

In Warranty Service

Customers, who own machines that are in warranty and require service, should contact our Warranty Department by email at help@longevity-inc.com to obtain a return authorization code. In addition to the warranty we offer, we would like for you to register your product on our website at www.longevity-inc.com/resources. Remember, warranty starts from the date of purchase. For your convenience, write your order information below so you can track your order in case you need warranty work.

Order No.: _____
Date of Purchase: _____
Warranty Period: _____

Out-of-Warranty Service

Customers, who own machines that are out of warranty and require service, should contact us for an estimate. Longevity offers an exchange program on out of warranty units. We also help non LONGEVITY customers with repairs, replacement, and service.

If your unit is not manufactured by Longevity and you cannot receive service from your manufacturer or seller, Longevity will lend out hand. Our warranty policy is also available for all plasma cutters and welders. For more information, please email us at HELP@longevity-inc.com

Warnings and Safety

Welding and plasma cutting may be dangerous to the operator and to bystanders, if the equipment is not operated properly. Welding or cutting must be performed in accordance with all relevant safety regulations. Carefully read and understand this instruction manual before installing and operating this equipment.

Changing function modes during welding may damage equipment.

Before welding, disconnect the electrode-holder cable from the equipment.

A circuit breaker is required to prevent electrical overload of the equipment.

Only high quality welding tools should be used.

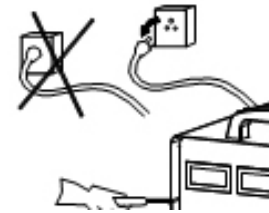

Electric Shock can be fatal.

Ensure that ground cable is connected in accordance with applicable safety codes.

Never touch electrodes, wires, or circuit components with bare hands. Wear dry welding gloves when welding.

The operator must be insulated from the work piece.



Smoke and gas can be harmful to health.

Ensure that the working area is well ventilated.

Avoid breathing smoke and gas generated during the welding process. Cutting and welding can cause cancer because of the smoke that comes from the welds and cuts.



Arc-light emission can be harmful to eyes and skin.

Always wear a welding helmet, anti-radiation glass, and work clothes while welding.

Ensure that people in or near the working area are protected.



Welding splash is a fire hazard.

Keep flammable material away from the work place.

Keep a fire extinguisher nearby, and have all personnel trained in its use.

Surface noise generated while welding or cutting can be harmful to hearing.



In the event of a machine fault.

Refer to this instruction manual.

If the fault cannot be determined, contact your local dealer or supplier for assistance.



Safety Tips

Consider the following tips to ensure safe operation of your welding/cutting equipment:

- Ensure that this welding equipment is installed in an area free of corrosive chemical gases, flammable gases or materials, and explosive chemicals.
- The area should contain little dust, and have a humidity of no more than 80%.
- Operate the welding equipment in an area sheltered from direct sunlight and precipitation. Work area temperature should be maintained at -10°C to +40°C;
- If, because of an overload, the machine suddenly stops, and it is necessary to restart it, leave the internal fan operating to lower the inside temperature.
- Always wear protective clothing and a welding mask to protect your skin.
- Wear safety goggles designed to darken the arc generated by your machine.
- Wear suitable noise protection to protect your hearing.
- Ensure that machine is grounded through the power cord or on the machine case.
- Never operate the machine in bare feet or on a wet floor.
- Never switch the machine off while it's in use. Doing so will damage the internal circuitry.
- Ensure that your circuit breaker is rated to handle the current requirements of your machine.
- Use a UL approved receptacles and plugs with your machine. Never hard wire the machine to main power.
- Work in a well ventilated area to avoid smoke. Keep your head out of the smoke. Ensure that air is flowing away from you to avoid inhaling smoke.
- Ensure proper ventilation through the machine's louvers. Maintain a distance of at least 12 inches between this cutting equipment and any other objects in the work area.
- Use a screen or curtain designed to keep passers by from viewing the arc.
- The arc spray and metal spray from machine use may cause nearby fires. Use caution.
- If, after reviewing this manual, you have any problems in setting up or operating your machine, contact us at help@longevity-inc.com.

Technical Specifications and Ratings

Rated input	Single-phase, 110/220V, 50/60Hz
Output	10-140A
Machine Type	IGBT Inverter
Duty Cycle ~ Stick	40% @ 140A
Duty Cycle ~ Lift TIG	25% @ 140A
Insulation Grade	⁺ - F
Weight	9 lbs
Dimensions (Length*Width*Height)	12.5”L x 4.5”W x 8.5”H



What's Included?

- 1 13 FT Ground Clamp
- 1 13 FT Stinger
- 1 Carrying Case
- 1 110/220 Adapter

Main Unit

Pictured: Stickweld 140 STL



Main Unit Knob/Button/Function:

1. **Current Display:** Welding Current display when machine is welding.
2. **Power Pilot Lamp:** The pilot lamp indicates that the machine is on when lit.
3. **Alarm Pilot Lamp:** When the machine has less voltage, is over current, or overheating, this pilot lamp will light up to indicate that the thermal overload protection has been activated.
4. **Welding Current Regulation:** Used to set your welding current.
5. **Conversion Switch:** Up= Stick Down= TIG
6. **Earth Connection:** Negative polarity output
7. **Welding Connection:** Positive polarity output.
8. **Power cord**
9. **Power Switch:** Use switch to turn on and off machines

STICK/ARC Welding

(Also known as MMA-Manual Metal Arc or Shielded Metal Arc Welding-SMAW)

Connect the Stick torch to the - terminal and Torch Control receptacles.

Connect the ground clamp to the + terminal and clamp the metal to be welded. Reverse the torch and ground connections for DCEP (Direct Current Electrode Positive).

DC Stick - Select Stick, DC, desired amps using Base cur knob, Pulse Mode off.

1. Insert electrode into electrode holder. Position the electrode for the most comfortable position so that the electrode can be held directly over the work piece with a slight angle.
2. Set Amperage to the recommended amperage by the electrode manufacturer. Strike an arc by swiping it briskly across the work piece in the same manner as one would strike a match. Alternatively, you may strike an arc with firm tapping motion against the work piece. Either method is acceptable. An arc should initiate. Continue to keep the arc going by holding the electrode off the work piece no more than the electrode width.
3. Continue the arc by feeding the electrode into the weld puddle while moving the electrode forward. This will take some coordination, but will be fairly easy to do after practice. Do not allow the arc to become too long, because air and slag can become entrapped in the metal. The sound of a proper arc will be similar to a gentle frying sound. A long arc will emit a humming sound. An arc that is too short may be extinguished and the electrode may stick to the work piece. If the electrode sticks, immediately release the electrode from the electrode holder and break the electrode loose by hand. If the flux breaks off, simply trim off the excess rod until flux and bare metal meet. A welding rod must have flux to shield the weld from the atmosphere or the weld will fail.

4. Use the Current control to change arc qualities. Adjust the amperage according to the recommendations of the electrode (welding rod) manufacturer for the type and size of the electrode used. Experimentation will be required to find the optimal setting desired. It is an excellent tool for out of position welding.

5. Electrode selection. Electrodes are usually given performance and characteristic ratings using a system of letters and numbers determined by the American Welding Society (AWS). The rating system includes the minimum tensile strength of the finished weld, the weld position (flat, vertical, horizontal, or overhead or a combination of two or more positions) and the flux type. Additional information may be given. Each manufacturer has their individual name and terminology as well.

As there is no general recommendation that can be made about a particular electrode selection, except for practice welds, a electrode designated by the AWS as E 6011, E 6013, E 7014, or E 7018 may be used, each having its own distinct features and purpose. These are among the most common electrodes used in the industry and are not difficult to find. E 6011 electrodes are not as smooth running as some of the other electrodes, but offer the advantage of being able to weld on rusty metal and contaminated surfaces. It is widely used and requires very little skill to begin using. This is not a particular endorsement of an E6011, rather a simple example of what may be used in developing proficient technique. It is recommended that a variety of electrodes be used and practiced with. Consultation with an experienced local welding supplier will help greatly in determining what welding electrode is the best for your given situation. Many times, samples or small packages of electrodes are available at relatively low cost.

Stick Electrode Chart Example: E 60 1 3

Strength

60--60,000 psi,

70--70,000 psi

Weld Position

1--All positions: Flat, Vertical, Horizontal, & Overhead

2--Flat Position or Horizontal Fillets Only

3--Flat Position Only

Weld Characteristics

0--Non-low hydrogen, DC Reverse polarity

1--Non-low hydrogen, AC or DC Reverse polarity

2--Non-low hydrogen, AC or DC Straight polarity

3--Non-low hydrogen, AC or DC Either polarity

4--Non-low hydrogen, iron powder coating, AC or DC Reverse polarity

5--Low-hydrogen, DC Reverse polarity

6--Low-hydrogen, AC or DC Reverse polarity

7--Non-low hydrogen, iron powder coating, AC or DC Reverse polarity

8--Low hydrogen, iron powder coating, AC or DC Reverse polarity

Polarity Definition

electrode negative =straight polarity (typical stock machine setup)

electrode positive = reverse polarity

Be sure to observe the electrode manufacturer recommendations regarding polarity. If the weld appears lumpy, porous or otherwise malformed, change the polarity of the ground cable and the electrode holder cable. Many electrodes run with in reverse polarity, (DCEP) setting. A few run with a straight polarity (DCEN). Some will run either way. For reverse polarity (DCEP) stick welding, swap the electrode holder and ground cable connections.

Proper weld identification: Overlap and undercutting are two main causes of weld failure. Proper washing of the weld bead into the sides or “toes” of the weld is important. Keep the welding electrode or the TIG tungsten and welding arc within the weld joint to prevent overlap. Pausing on the sides of the welds to wait for the sides to fill reduces the chance of undercutting, even if the current is a little too high. If it is possible, with any practice weld, cut the joint down the middle, lengthwise, or place the weld in a vice and use a hammer to bend the metal over the weld area until it is either broken or bent 90 degrees. This destructive testing method will help you improve your skill by revealing faults and flaws in your welds.

Stick (SMAW) Electrode Welding

Stick, the most basic of welding processes, offers the easiest option for joining steel and other metals. Although it produces the least pretties or cleanest welds, ARC/STICK welding gets the job done! Stick welding power sources deliver inexpensive options for welding versatility, portability and reliability. Stick joins metals when an arc is struck between the electrode and the work piece, creating a weld pool and depositing a consumable metal electrode into the joint. The electrode's protective coating also acts as a shielding gas, protecting the weld and ensuring its purity and strength. Best for windy conditions and adverse environments.

If you're not familiar with Stick (SMAW) welding basics, the following information can make choosing an electrode easier.

Recommended Stick Electrodes			
Common Steel Electrodes			
AWS Class	Position	Polarity	Usage
A0611	ALL	AC DCEN DCEP	Deep penetrating All- purpose stick electrode. Used on carbon/galvanized steel. Does great with medium rusty, or painted metals 60,000 PSI, tensile strength.
E6013	ALL	AC DCEN DCEP	Mild to medial penetrating all-purpose stick electrode. Carbon Steel 60,000 PSI Tensile Strength
E7014	ALL	AC DCEN DCEP	Best when you have High-Deposition rates Good for light penetration and fast speeds 70,000 PSI tensile strength
E7018	ALL	AC DCEN DCEP	Low Hydrogen stick electrode All carbon steels- Great for tack welding, or welds that are in awkward positions 70,000 PSI tensile strength
E7018AC	ALL	AC DCEN DCEP	Low Hydrogen stick electrode Good for medium and high-carbon steels (on medium-high voltage AC welders) 70,000 PSI tensile strength
Specialty Stick Welding Electrodes			
AWS CLASS	Position	Polarity	Usage
Stainless Steel 308L	ALL	AC/DC	301-305, and 308 base metal Great for build-up and cladding Slag easily removed
Stainless 312 Plus	ALL	AC/DC	Metals that are hard to weld; stainless, high carbon, cast, and high nickel steels. Has a strong resistance to moisture Self-detaching slag
Cutting/ Chamfering	ALL	AC/DC	Cutting/beveling of all metals, which include; stainless steels, aluminum, and copper Great for weld joint removal
Flux Coated Brazing			Brazing of steel, cast iron, nickel/some nickel alloys, and copper/some copper alloys Brazing fuels are needed (oxyacetylene.. etc)
Aluminum 4043		DC	Flat horizontal and vertical aluminum welding jobs ngth.
Nickel 55 Cast Iron	ALL	AC/DC	55% nickel on cast iron High strength—stronger than nickel 99 Machinable
Nickel 99 Cast Iron	ALL	AC/DC	99% nickel on cast iron Ductile strength is higher than nickel 55 Easier to machine than nickel 55
Hard Surfacing Overlay		AC/DC	Chrome coated steels Wear and impact resistant Good for use on bulldozer blades, plow shears and metal to earth applications
Hard Surfacing Buildup		AC/DC	Chrome-manganese steel Great impact Hardens to 550-55 Rockwell C
DCEN= DC Electrode Negative (Straight Polarity) DCEP= DC Electrode Positive (Reverse Polarity)			

Electrode Polarity Chart

Electrode	DC*	AC	Position	Penetration	Usage
6010	EP	—	All	Deep	Min. Prep, Rough, High Spatter
6011	EP	✓	All	Deep	
6013	EP, EN	✓	All	Low	General
7014	EP, EN	✓	All	Medium	Smooth, Easy, Fast
7018	EP	✓	All	Low	Low Hydrogen, Strong
7024	EP, EN	✓	Flat, Horz. Fillet	Low	Smooth, Easy, Faster
308L	EP	✓	All	Low	Stainless Steel

*EP = Electrode Positive (Reverse Polarity); EN = Electrode Negative (Straight Polarity)

Electrode Amperage Chart

Elect.	Dia. (in.)	Amperage Range					
		MIN.	50A	100A	150A	200A	MAX.
6010 & 6011	3/32						
	1/8						
	5/32						
	3/16						
6013	5/64						
	3/32						
	1/8 5/32						
7014	3/32						
	1/8						
	5/32						
7018	3/32						
	1/8						
	5/32						
308L	3/32						
	1/8						
	5/32						

Striking an Arc

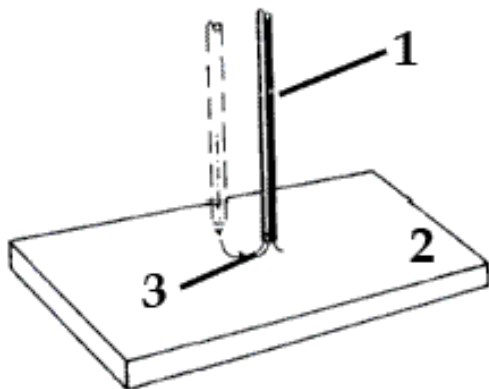
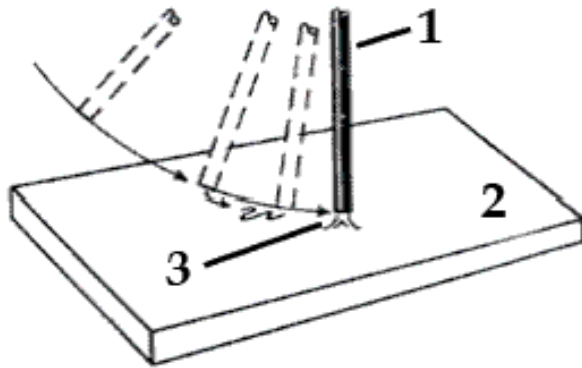

1 Electrode; 2 Workpiece; 3 Arc

Helpful Hints

- Use a drag technique for most applications.
- Take precautions with flying materials when chipping slag.
- Keep electrodes clean and dry - follow manufacturer instructions.
- Common steel electrodes (refer to chart above).
- Penetration: DCEN- Less penetration; AC - Medium (can be more spatter also); DCEP - Most penetration

Catalog and Capabilities

LONGEVITY has what you need for stick welding, from welders to welding supplies and protective clothing. Stick welders come in two basic classifications; 115V stick welders and 230/460V stick welders. Stick Electrodes or welding rod for stick welding are available in stainless steel, carbon steel, low alloy steel, maintenance alloy, hard facing, nickel alloy, and magnesium

Routine Maintenance

The life of your machine and the quality of the work performed using your machine, will be enhanced by practicing periodic routine maintenance.

- At regular intervals, clear dust that may accumulate in the machine using clean and dry compressed air. If the working condition has heavy smoke and pollution, the welding machine should be cleaned once a month.
- Keep the machine exterior clean with mild soap and water.
- Do not walk on or store items on the cables or cords.
- Do not jar, drop, or stack items on top of the machine.
- Always connect the machine to a proper grounded electrical outlet.
- Always check the torch consumables before and after use and ensure that they are clear of obstructions, and that no parts are damaged.
- Replace any worn or damaged consumables before using machine.
- For periods of prolonged non-use, remove cables and store them in their original boxes in a cool dry place, free of bug infestation.

LONGEVITY® Global, Inc. thanks you for your purchase and the opportunity to be able to serve you. If, after reviewing this manual, you have any problems in setting up or operating your machine, contact us at help@longevity-inc.com.

LONGEVITY® Global, Inc.

Toll-Free 1-877-LONG-INC / 1-877-566-4462

Website: www.longevity-inc.com

Sales: sales@longevity-inc.com

Customer Service: help@longevity-inc.com

Dealers: dealers@longevity-inc.com

Please join our welding forums to share welding tips and tricks, to receive useful information from customers who also use our products, and to be a part of the LONGEVITY® welding community at www.freeweldingforum.com

For the coolest LONGEVITY sponsored race teams plus a complete racing forum that covers everything from Drag Racing to RC Car Racing, please check out www.longevity-racing.com!

Enjoy your new welding machine from LONGEVITY! Thanks again!