

# HOME DECORATORS *collection*

BF-20430 Oxford Collection 4 drawer Letter Size file Cabinet

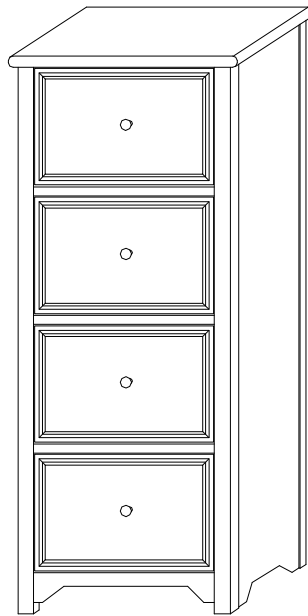



## ASSEMBLY INSTRUCTIONS





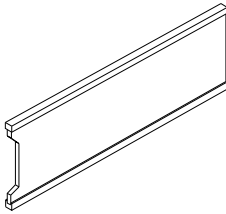
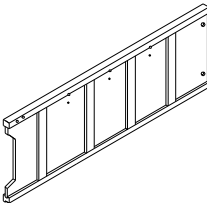

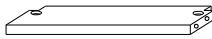
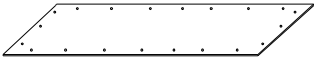
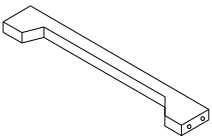
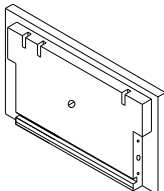
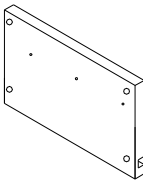
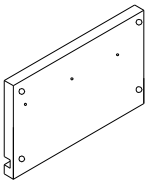
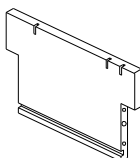





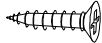

Made In China

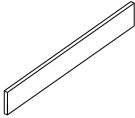

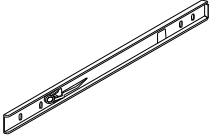
Thank you for purchasing this quality product. Be sure to check all packing material carefully for small parts, which may have come loose inside the carton during shipment. Count all parts and material hardware, Compare with parts list to be sure all parts are present. If any parts are missing or damaged, phone, fax, or mail to our Customer Service Department. For efficient and speedy service please indicate the model number and code letter of part(s) need.

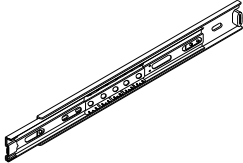
**IMPORTANT NOTE:** Follow instructions listed below in proper sequence as numbered to assure fast, easy and correct assembly.

<b>PARTS LIST</b>		
<b>A</b>	<b>B</b>	<b>C</b>
		
TOP PANEL-1PC	RIGHT SIDE PANEL-1PC	LEFT SIDE PANEL-1PC
<b>D</b>	<b>E</b>	<b>F</b>
		
BOTTOM PANEL-1PC	ACROSS PANELS-3PCS	BACK PANEL-1PC
<b>G</b>	<b>H</b>	<b>I</b>
		
LOW PANEL-1PC	DRAWER PANEL FRONTS-4PCS	RIGHT DRAWER PANEL SIDES-4PCS
<b>J</b>	<b>K</b>	<b>L</b>
		
LEFT DRAWER PANEL SIDES-4PCS	DRAWER PANEL BACKS-4PCS	DRAWER PANEL BOTTOMS-4PCS

<p>M</p>  <p>CAM-LOCKS-14PCS</p>	<p>N</p>  <p>CAM-BOLTS-14PCS</p>	<p>P</p>  <p>SCREWS-32PCS</p>
<p>Q</p>  <p>DOWELS-26PCS</p>	<p>R</p>  <p>SCREWS-22PCS</p>	<p>S</p>  <p>KNOBS-4PCS</p>
<p>T</p>  <p>SCREWS-4PCS</p>	<p>U</p>  <p>FILE HANGERS-8PCS</p>	<p>V</p>  <p>SCREWS-48PCS</p>
<p>W</p>  <p>INNER SLIDES-8PCS</p>	<p>Y</p>  <p>CAM-TOOL-1PC</p>	<p>Z</p>  <p>OUTER SLIDERS-8PCS</p>
<p>W1 to prevent tipping</p>  <p>HOOKS-2PCS</p>	<p>X1 to prevent tipping</p>  <p>SCREWS-2PCS</p>	<p>Y1 to prevent tipping</p>  <p>HANGERS-2PCS</p>
<p>Z1 to prevent tipping</p>  <p>SCREWS-2PCS</p>		

REMARK: THE LETTER STICKED IS THE BACK SIDE.

## HOW TO SEPARATE GLIDES

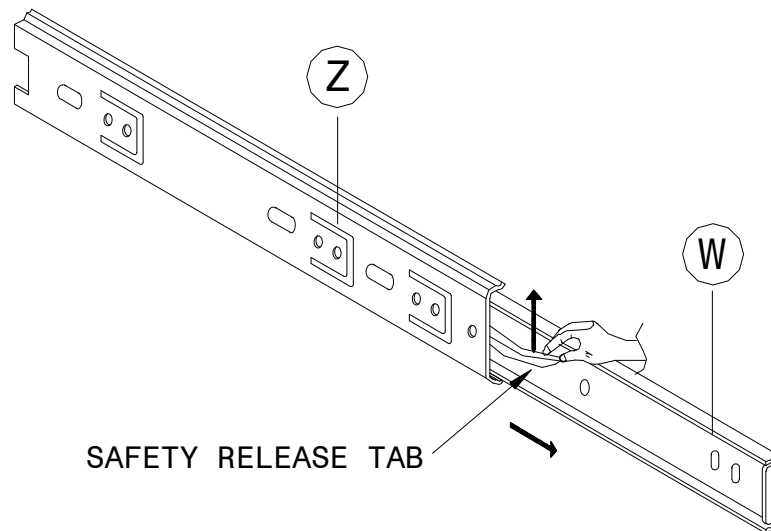

PRIOR TO ASSEMBLY, WE SUGGEST SEPARATING THE INNER GLIDES FROM THE OUTER-GLIDES, SIMPLY PULL THE LEFT/RIGHT INNER GLIDES FROM THE OUTER GLIDES EXPOSING A SMALL BLACK SAFELY RELEASE TAB, BY PUSHING THE SAFETY RELEASE TAB. YOU WILL BE ABLE TO SEPARATE THE GLIDE.

NOTE: • UPON OPENING THOROUGHLY CLEAN ALL WOODS SURFACES TO REMOVE DUST AND DIRT THAT MAY HAVE SETTLED ONTO FINISH DURING SHIPMENT. IN ORDER TO PREVENT DAMAGE DURING ASSEMBLY, PLEASE ASSEMBLE THIS ITEM WITH AT LEAST TWO PEOPLE.

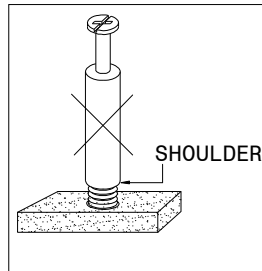
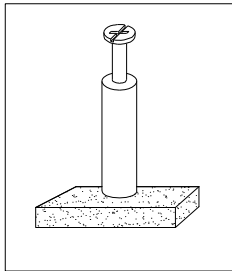

NOTE: TURN THE CAM-BOLT SCREWS UNTIL THEY ARE TIGHT, THE SHOULDER SHOULD BE AGAINST THE SURFACE OF THE PART.

## HOW TO USE THE CAM-TOOL

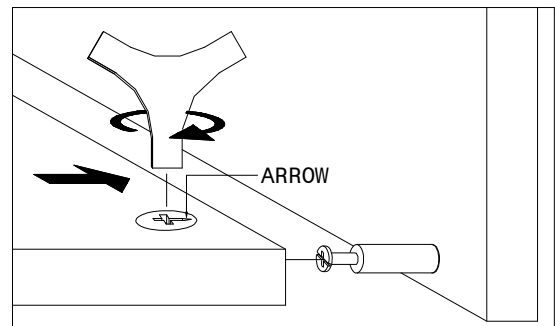
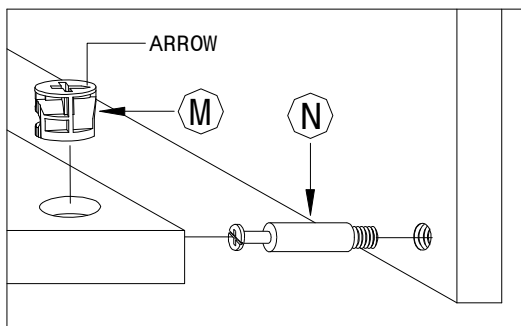

NOTE: • THE ARROWS ON THE HIDDEN CAM-LOCKS SHOULD POINT TO THE CAM-BOLTS.

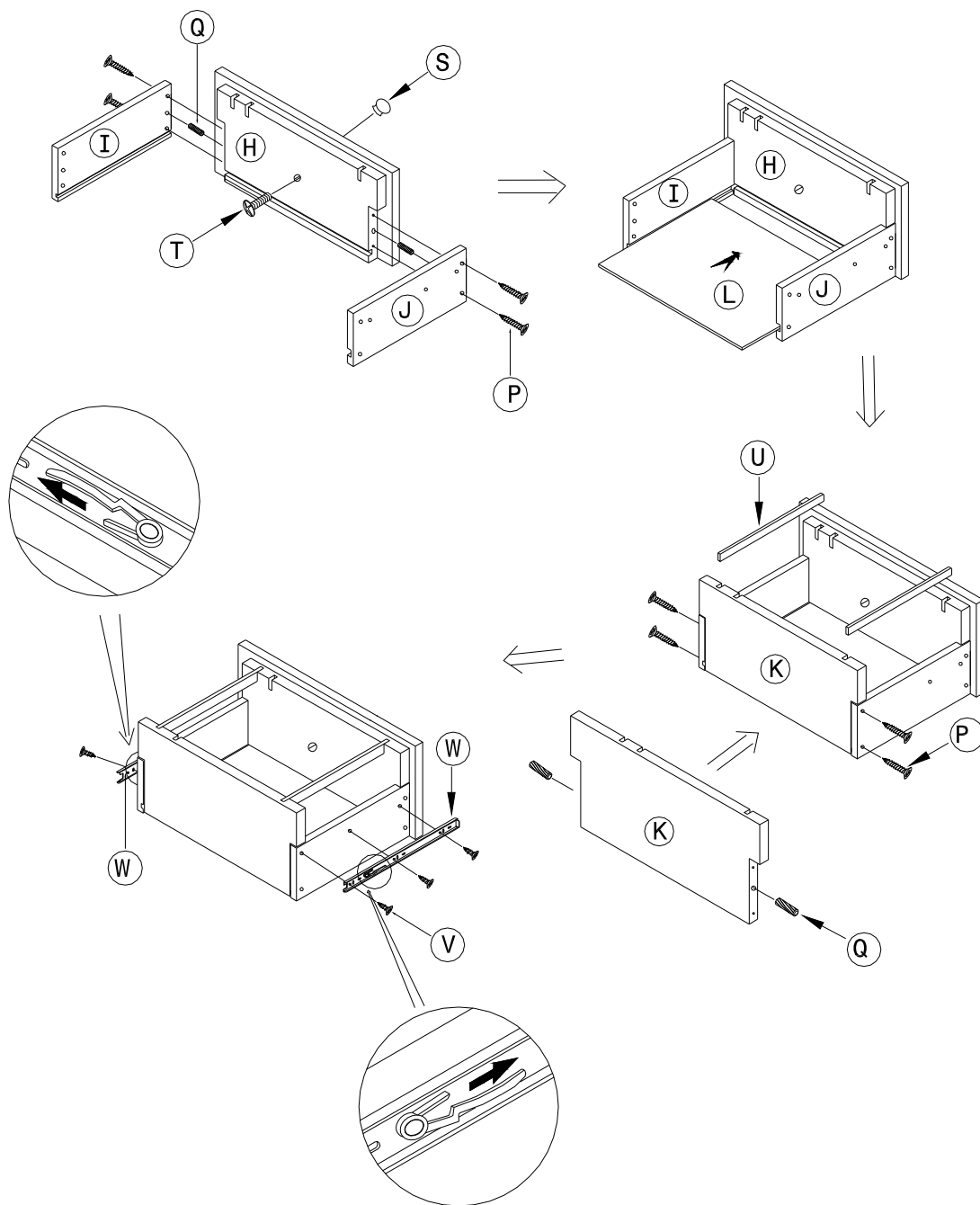

### 1) .ASSEMBLE THE DRAWER.

- INSERT DOWELS(Q) INTO HOLES IN PANEL(H) AND ATTACH SIDE PANELS(I/J) USING SCREWS(P) .
- ATTACH THE KNOB(S) TO FRONT DRAWER PANEL(H) USING SCREWS(T) .
- INSERT BOTTOM DRAWER PANEL(L) INTO SLOT IN SIDE DRAWER PANELS(I/J) .
- INSERT THE DOWELS(Q) INTO HOLES IN BACK DRAWER PANEL(K) AND ATTACH USING SCREWS(P) .
- INSERT THE FILE HANGERS(U) INTO THE CUT-OUT OF DRAWER PANEL FRONT&BACK .
- FINALLY, ATTACH INNER SLIDES(W) TO DRAWER PANEL SIDES(I/J) USING SCREWS(V) .

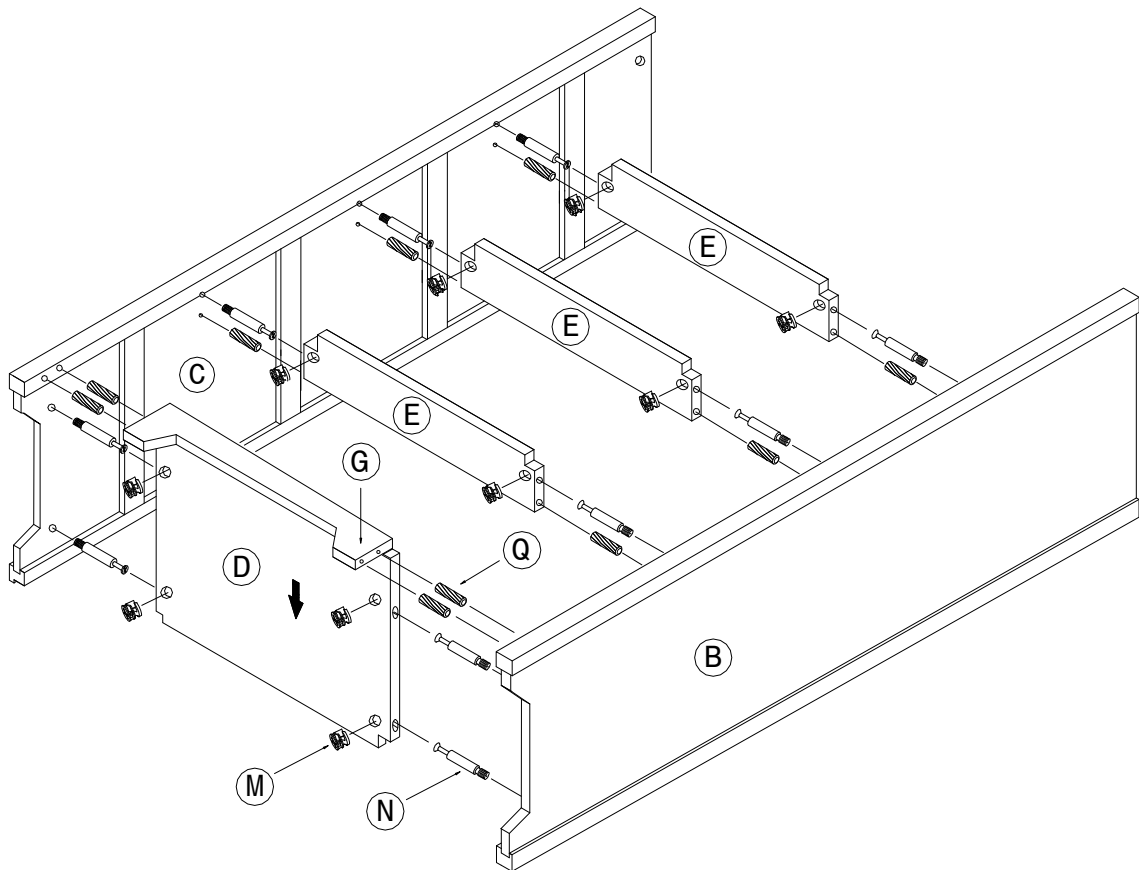

**2) .ASSEMBLE THE SIDE PANEL(B/C) .**

- INSERT THE DOWELS(Q) INTO HOLES IN ACROSS/LOW PANEL(E/G) .
- ROTATE THE 10 CAM-BOLTS(N) INTO HOLES IN SIDE PANELS(B/C) .
- PLACE THE CAM-BOLTS(N) INTO HOLES IN PANELS(E/D) AND ATTACH USING CAM-LOCKS(M) .

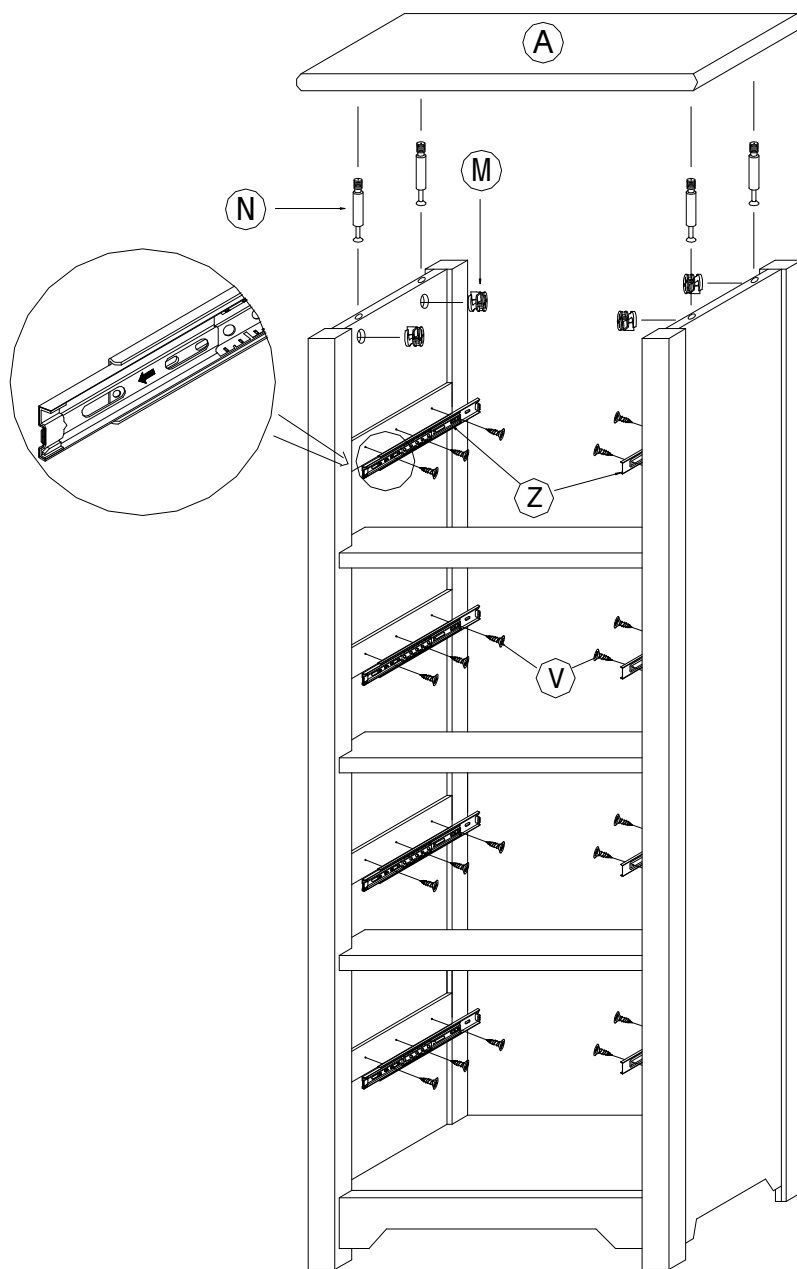

### 3) .ASSEMBLE THE TOP PANEL(A) .

- ROTATE THE 4 CAM-BOLTS(N) INTO HOLES IN TOP PANEL(A) .
- PLACE THE CAM-BOLTS(N) INTO HOLES IN SIDE PANELS(B/C) AND ATTACH USING CAM-LOCKS(M) .
- ATTACH THE OUTER SLIDES(Z) TO SIDE PANELS(C/B) USING SCREWS(V) .



NOTE: ALL DRAWER WILL BE ATTACHED TO THE SLIDES AS DESCRIBED BELOW.

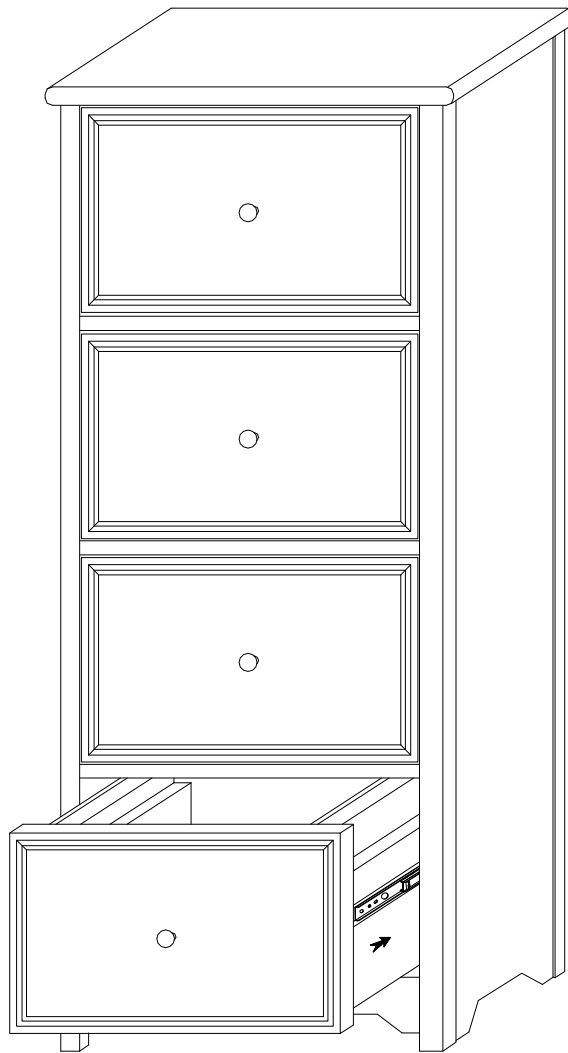

4) ASSEMBLE THE DRAWERS.

- SLIDE THE DRAWER INNER SLIDES INTO OUTER SLIDES.

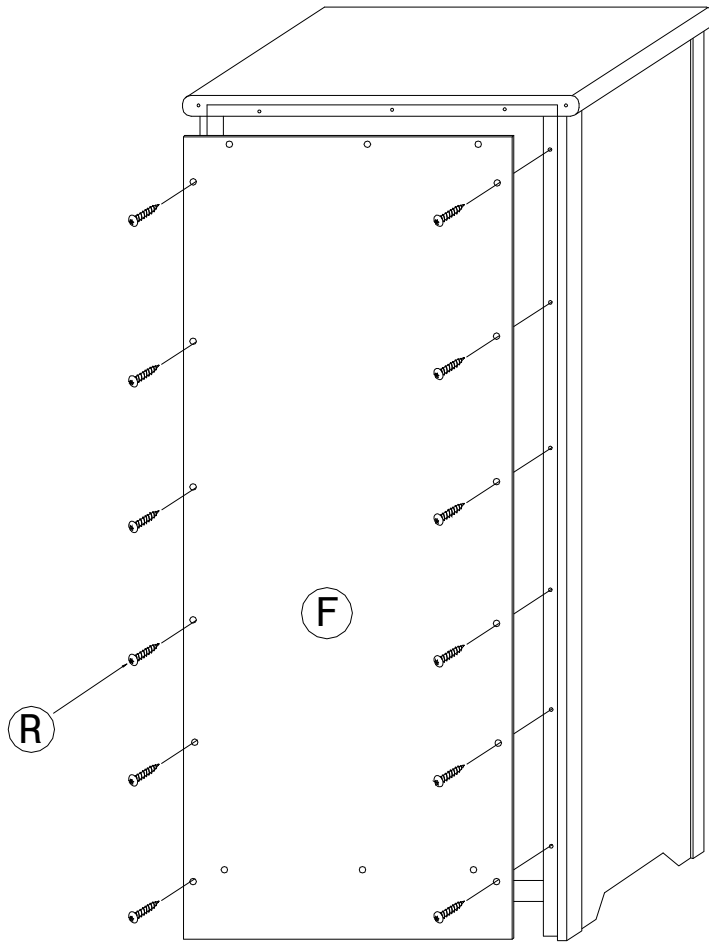

5) ASSEMBLE THE BACK PANEL (F) .

- ATTACH BACK PANEL (F) USING SCREWS (R) INTO THE REAR OF SIDE, TOP, AND BOTTOM PANEL .



## Warning

The anti-tip hardware must be used as part of assembly!

- ATTACH 2 HOOKS(W1) USING 2 SCREWS(X1) IN THE PREDRILLED HOLES OF REAR TOP PANEL.

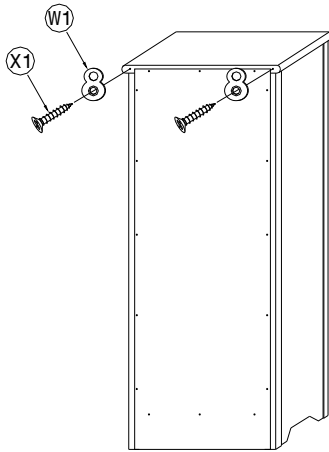

- DRILL TWO HOLES INTO WALL, PLEASE REFER TO THE REAR TOP PANEL'S HOLE DISTANCE AND HEIGHT.
- PUT 2 HANGERS(Y1) INTO HOLES IN WALL AND ROTATE 2 SCREWS(Z1) INTO HANGERS(Y1).

