



URIMAT®

Swiss quality – since 1998.

EVERY DROP COUNTS

Welcome to URIMAT



Welcome to URIMAT

URIMAT is a leading manufacturer of environmentally friendly products in the sanitary ware industry.

In a place where others are passive, URIMAT is actively setting new trends and standards on a daily basis. The waterless urinals made by the Swiss manufacturer URIMAT are enjoying worldwide acceptance and simultaneously bringing hygiene and ecological protection to thousands of washrooms around the globe. As they discover the innovative technology and the high value retention of our products, new customers are placing their confidence in our solution every day, thereby actively helping to save millions of litres of clean drinking water. In regions where this valuable resource is in short supply, such arguments are becoming ever more crucial in an era of climate change.

As a market leader, URIMAT is fully committed to ecological sustainability. Our products are manufactured using eco-friendly materials and production processes. When choosing our partners we emphasise carbon-neutral production and high ethical standards.

Our uncompromising quality control and leading technology guarantee durable products with odourless, hygienic and ecological operation.

Make a statement today.
Choose URIMAT.

Thank you very much! The URIMAT Team.



Used worldwide

You're in good company
with URIMAT

When you choose to rely on the technology of the market leader – the waterless urinals by URIMAT – you are in excellent company.

Take McDonald's, for example – A global corporation that subscribes to high ecological principles and is committed to sustainability. By installing URIMAT in their premises worldwide, McDonald's is sending a clear message and saving billions of litres of valuable drinking water.

In virtually every industry, we can name prestigious references that place their confidence in us every day. Make a statement now! Choose URIMAT!

URIMAT

The ecological environmental system.



- 1 High-tech polycarbonate bowl, carbon-neutral manufacturing, 100% recyclable
- 2 Unique odour trap technology with integrated cleaning system Saving minimum 100,000 litres of drinking water a year per urinal = 17.5 kg less CO₂
- 3 Microbiological cleaning system
- 4 Financing possibility through advertising

URIMAT sets standards

As a leading company for waterless sanitary technology, URIMAT is continually redefining the quality standard. Our constant striving for new solutions to protect that precious resource, water, have been endorsed over recent years by numerous renowned international environmental awards and certifications.

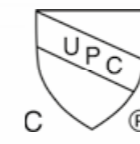

URIMAT Water is life*.

URIMAT is a leading producer of environmentally friendly products in the sanitary ware industry



* Around 71% of the earth's surface is covered by water. But only 0.3% of all the water on the planet is available in streams, rivers and groundwater for potential use as drinking water.

The original.

The waterless urinals from the market leader at a glance!



Model	URIMAT eco	URIMAT ecoplus	URIMAT ecoinfo	URIMAT ecovideo	URIMAT compactplus	URIMAT compactinfo	URIMAT compactvideo	URIMAT ceramic	URIMAT ceramiccompact	URIMAT inox
Article code	15.001	16.001	11.001	16.981	14.001	14.101	14.981	12.201	12.301	18.001
Colour	● white*	● white*	● white*	● white*	● white*	● white*	● white*	● white*	● white*	 available in all RAL colours (upon request)
Weight	4,2 kg	4,4 kg	4,7 kg	5,5 kg	3,5 kg	3,8 kg	4,5 kg	21 kg	12,5 kg	6 kg
Special feature		passive advertising display	illuminated advertising display	with LCD video display	passive advertising display	illuminated advertising display	with LCD video display			
Technology			LED Display	WiFi and USB		LED Display	WiFi and USB			

* other colours upon request

Model ranges eco and compact

Innovative and functionally designed urinals made from durable high-tech plastic. No water, no chemicals, no odours. The patented mechanical drain trap and microbiological cleaning agents guarantee trouble-free, odourless operation.

Dimensions (in mm)

eco

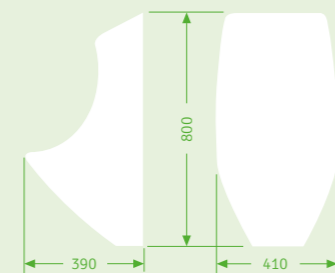

compact

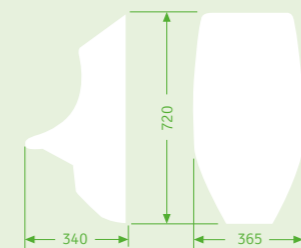

Model range ceramic

Elegance meets technology. The complete absence of a flushing rim and sharp edges in the vitreous china urinals from URIMAT actively avoid any build-up of deposits. The non-porous glaze of the URIMAT ceramic bowl ensures that no residues are left. No water, no chemicals, no odour. The patented mechanical drain trap and the microbiological cleaning agents guarantee trouble-free, odourless operation.

Dimensions (in mm)

ceramic

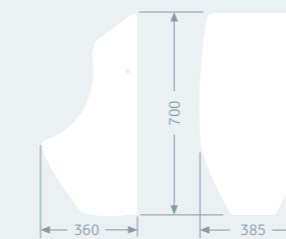

ceramiccompact

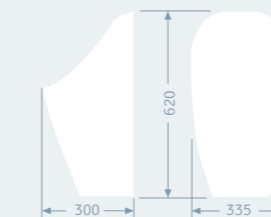

Model range inox

The combination of intelligent concept and perfect elegance. The urinal is made completely of V2A stainless steel to an exclusive design developed by URIMAT. Its negative, inward-curved frame is what gives it its unique, inimitable form, impressing with clear, elegant contours. The splash-preventing shape protects the surroundings and keeps marks off the floor, which makes for far less cleaning. It is light, weighing just 6kg, and easy to install thanks to a full-faced mounting frame. The inox urinal is also acid-resistant, fire-proof and available in all RAL colours. It hardly needs adding that this model range also offers all the advantages of the waterless URIMAT system.

Dimensions (in mm)

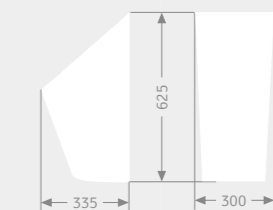

MB-ActiveTrap

Sophisticated technology for the most basic of needs.

The URIMAT MB-ActiveTrap collects the urine and channels it into the waste pipe without flushing, while at the same time sealing in any odours. Fluids are channelled via a vertical membrane straight into the sewage system. Above the membrane there is a microbiological cleaning block which prevents build-up of deposits both inside the odour seal unit and in the waste pipe. As soon as fluids stop flowing through the membrane, it automatically forms an air-tight seal.

After the MB-ActiveCube has dissolved, the red surface beneath the transparent cover signals that the odour trap has to be replaced.

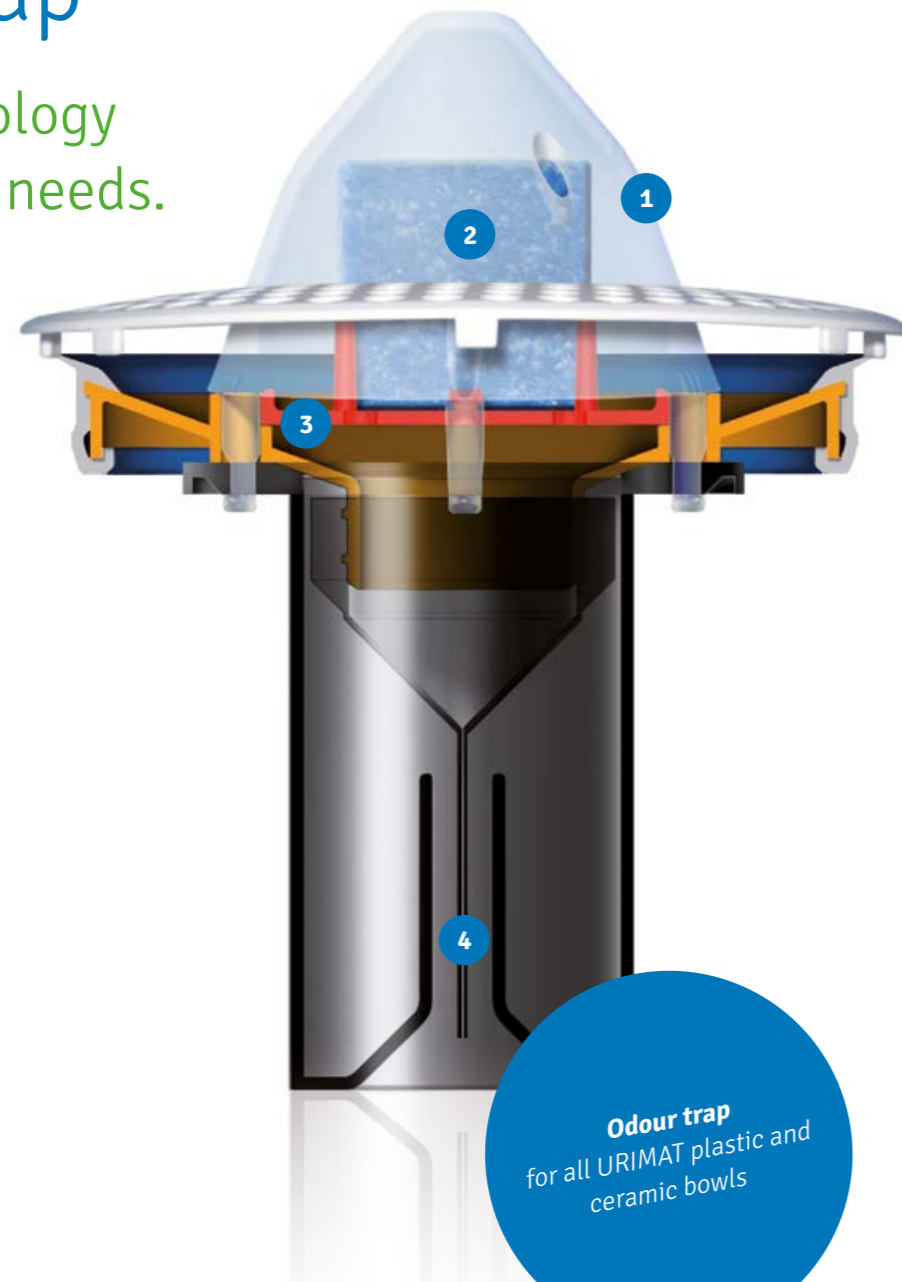

Odour trap for all URIMAT plastic and ceramic bowls

The patent for 100% odour-free function

1 Patented three-way control

The cover of the integrated MB-ActiveCube has three settings which regulate the efficiency of the block, thereby controlling its effective service life.

2 Integrated MB-ActiveCube

The integrated MB-ActiveCube improves hygiene, reduces deposits and prevents the inside of the odour trap and the waste pipe becoming encrusted with organic matter, urine deposits and fats.

3 Lifecycle indicator

After the MB-ActiveCube has dissolved, the red surface beneath the transparent cover signals that the odour trap has to be replaced.

4 Vertically sealing membrane system

The vertical membrane technology guarantees that odours are completely sealed away and is able to withstand both negative and positive pressures. It is impossible for gases from the sewage system to escape.

MB-ActiveCleaner

PH-neutral, biological and sustainable.

Dermatologically tested for skin-friendliness and found to be «very good». MB-ActiveCleaner eliminates the bad odours caused when organic matter decomposes. It is particularly well suited for maintenance cleaning and odour elimination in heavily used washrooms & sanitary facilities.

MB-ActiveCleaner contains micro-organisms that penetrate the pores (joints) and destroy any odours caused by organic residues deposited there, leaving a pleasant and lasting freshness. Used daily, it prevents odours from developing.

By delaying re-soiling, MB-ActiveCleaner makes an active contribution to maintaining cleanliness in all environments.



Areas of application

- › Toilets and sanitary facilities
- › Washrooms and showers
- › Façades, passages and stairways
- › Waste containers and refuse collection stations
- › Floors, carpets etc.

URIMAT sets standards



Advertising with URIMAT

A high-yield investment.

URIMAT is not only a market leader among waterless urinals, but at the same time offers an advertising medium with significant reach in a clearly defined target group. There is no changing the channel or turning the page. Your advertising message is viewed on average for 40 seconds.

Depending on the model, the urinals from URIMAT offer either static advertising displays or high-resolution LCD-screens with animated messages that hit home within your target group.

A modern and audience-specific medium that allows you or your customers to address your target group in the most effective way. The URIMAT media partners will be pleased to advise you.

The Acceptance Study

- › 93% of all those surveyed said the advertising screen was the first thing they noticed on the URIMAT!
- › 96% find the advertising on the URIMAT positive or aren't bothered by it!
- › 90% remember the message on the URIMAT advertising display!
- › captive audience of
- › 40 seconds
- › no divergence loss

The Acceptance Study was performed in Switzerland by the renowned market research institute, IHA-GfK.

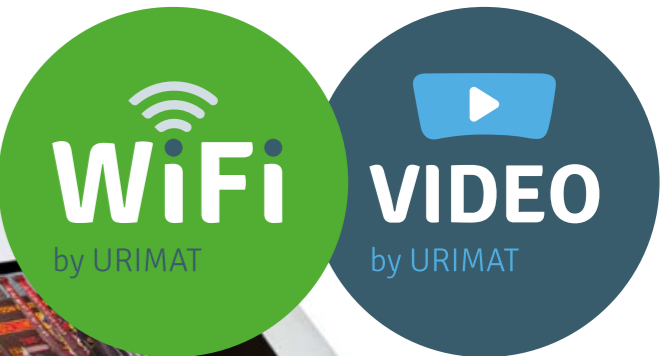

Partition wall and design element in one

Urinal partition walls by URIMAT!

URIMAT uses elegantly shaped urinal partition walls made of Trespa®. These durable dividers have a smooth surface, good hygiene properties and are extremely robust. In addition, they are also very easy to clean.

URIMAT urinal-partition walls make a perfect design element in your washroom.*

* Also available in toughened safety glass



Ultimately only hard facts count!

Arguments that have persuaded even URIMAT's most demanding customers:

- Annual savings of at least 100,000 litres of drinking water per urinal per year
- No Water consumption
- No urine scale build-up
- No chemicals
- CO2 reduction (at least 175g per m3 water)
- No flushing systems necessary
- CO2-neutral manufacturing
- Worldwide patented system and design
- Microbiological cleaning system
- Advertising Income possible
- Durable materials
- All-round service with our own staff
- Successful since 1998
- Swiss quality
- Leasing options available

Mounting frame

The practical mounting element for new installation and renovation

The URIMAT mounting frame ensures an accurate fit and simple assembly involving just four fixing screws. The four mounting brackets ensure highly secure installation and enable precise horizontal and vertical alignment.

- › **Art. 58.515**
Makro-Fix mounting
for URIMAT plastic bowls
- › **Art. 58.520**
Kera-Fix mounting
for URIMAT ceramic bowls





URIMAT®

Swiss quality – since 1998.



URIMAT Schweiz AG
Feldbachstrasse 81
CH-8714 Feldbach

+41 (0)55 251 52 30
www.urimat.ch