

OPERATING MANUAL & PARTS LIST

**9661051C, 9661201C,
9661301C & 9661401C**

PALMGREN®

**0.5-TON, 2-TON, 3-TON & 4-TON
ARBOR PRESS WITH
DEPTH STOP COLLAR**

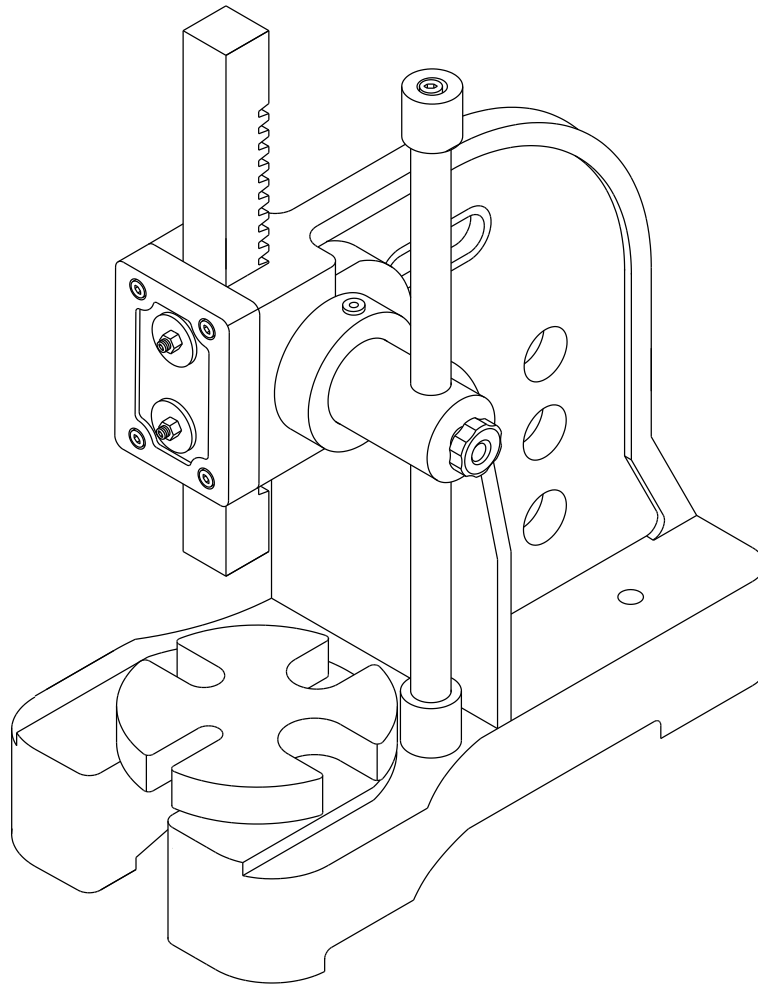

Read carefully and follow all safety rules and operating instructions before first use of this product.

DESCRIPTION

Palmgren Arbor Presses are designed for riveting, squeezing, bending, punching, flattening, removing a bearing or pressing in bearings. Removable, rotating, machined anvil has 4-slots to provide convenient support for workpieces that vary in size and shape. Presses are suited for work in production lines as well as in machine shops, automotive repair shops and home workshops. Model 9661051 is a 0.5-ton press, 9661201 is a 2-ton press, 9661301 is a 3-ton press and 9661401 is a 4-ton press.

SAFETY RULES

- For best operation, the arbor press must be bolted to a stationary object that is also affixed to the floor.
- When using the press, be sure the work is mounted securely in it. Do not attempt to use the press with the workpiece mounted on an angle.
- Use only accessories designed for the arbor press. Attachments and equipment used in the pressing operation must be as strong as the press. Use steel collars and blocks to press against the workpiece.
- Do not overload the press by using handle extensions (cheater bars).
- When not in use, the ram should be in the down position to prevent accidents.
- Know the arbor press and accessories. Read and understand owner's manual.
- Wear a face shield or safety glasses.
- Never place hands in jeopardy.
- Always check your set up, i.e., see that the ram contacts workpiece squarely before applying pressure.
- Keep your mind on your work. Be alert.
- Make sure workpiece, punch, anvil and accessories are securely clamped.
- Don't force the arbor press or its accessories.

DIMENSIONS

Model Type		9661051C	9661201C	9661301C	9661401C
Base Length	L	9 ³ / ₈ "	16"	17 ⁷ / ₈ "	21"
Base Width	W	5 ¹ / ₈ "	7 ⁷ / ₈ "	9 ¹ / ₂ "	10 ³ / ₄ "
Height	H	9 ³ / ₈ "	15 ¹ / ₈ "	21 ¹ / ₂ "	27"
Max. Work Height	A	4 ⁵ / ₈ "	8"	12 ¹ / ₂ "	15 ³ / ₄ "
Swing	2B	7 ³ / ₈ "	11 ⁷ / ₈ "	12 ¹ / ₈ "	16 ³ / ₄ "
Anvil Diameter	D	3 ³ / ₈ "	6 ⁵ / ₈ "	6 ⁵ / ₈ "	9 ³ / ₄ "
Ram Dimension	R x R	3/4 x 3/4"	1 ¹ / ₄ x 1 ¹ / ₄ "	1 ¹ / ₂ x 1 ¹ / ₂ "	1 ³ / ₄ x 1 ³ / ₄ "

Refer to Figure 1.

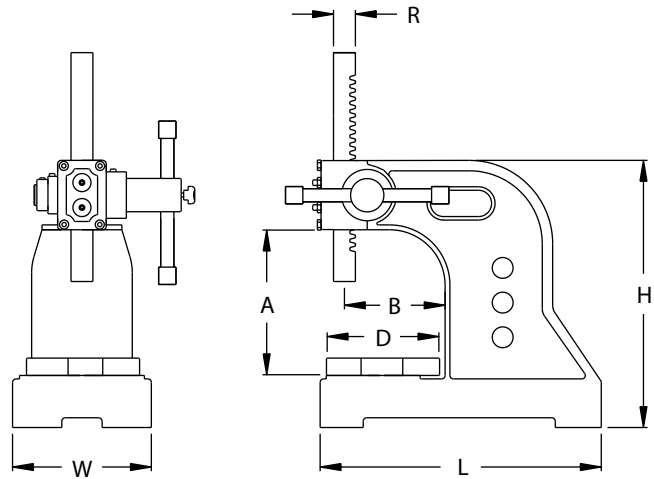

Figure 1 - Dimensions

ASSEMBLY

Refer to Figure 2.

- Mount arbor press to bench or stand. Secure arbor press using two mounting holes on the body (Ref. No. 1). (Hardware is not supplied.)
- The 0.5 and 2-Ton presses are completely assembled. The handle needs to be installed on the 3 and 4-Ton presses. To install handle, remove cap and bolt from handle (Ref. Nos. 4, 5 and 7). Insert handle into pinion (Ref. No. 3) and replace cap and bolt. Secure handle in position with knob (Ref. No. 6).
- To use with a punch, remove pinion retaining ring and set screw (Ref. Nos. 9 and 10) from pinion. Remove pinion from the body. Remove ram (Ref. No. 2), mount ram upside down so the punch hole is facing down. Replace pinion, pinion retaining ring and set screw. Insert the punch (Ref. No. 17) best suited to the job. Magnet inside ram will secure punch in position. Set screws (Ref. No. 11) will ease or restrict the ram action. Adjust to your requirements.

DEPTH STOP COLLAR INSTALLATION:

The Depth Stop Collar allows to precisely adjust and/or limit the Arbor Press Ram Stroke. To install the Depth Stop Collar:

- Position the Collar over the Ram such that the two set screws is on the front side of the arbor press.



- Loosen the two set screws slightly with a wrench (not supplied) and slide the Collar over the Ram. Position the Collar at the desired height and tighten both the set screws

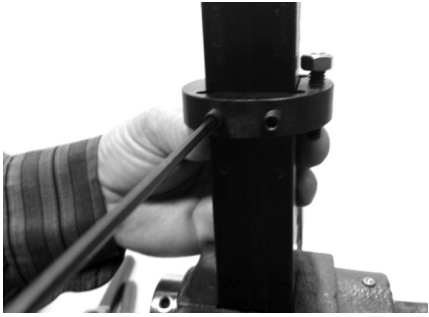

- For precise depth stop adjustment, turn the screw on the hex nut to the desired height. Secure the position of the screw by tightening the hex nut until it bottoms out on the arbor press frame.

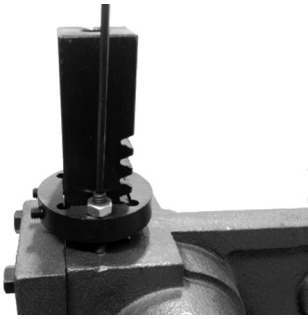

MAINTENANCE

- Oil the pinion periodically through the oil fitting, and grease the ram rack whenever necessary. Keep a light film of oil on machined surface to prevent rust. Keep work area clean. Clean the arbor press of dirt and debris after every use.
- If the ram is loose and drops by itself, loosen hex nuts and tighten screws (Ref. Nos. 11 and 12) for adjustment. All screws should be tightened with the same amount of pressure. Secure set screws by tightening nuts.

WARRANTY

Palmgren warrants their products to be free of defects in material or workmanship. This warranty does not cover defects due directly or indirectly to misuse, abuse, normal wear and tear, failure to properly maintain the product, heated, ground or otherwise altered, or used for a purpose other than that for which it was intended. The warranty does not cover expendable and/or wear parts (i.e. v-belts, coated screws, abrasives), damage to tools arising from alteration, abuse or use other than their intended purpose, packing and freight. The duration of this warranty is expressly limited to the terms noted below beginning from the date of delivery to the original user. The Palmgren products carry the following warranties on parts with a 1 year warranty on labor:

- | | |
|---|--------------------------------|
| • USA Machine vises – Lifetime | • Finishing machines – 2 years |
| • IQ Machine vises – Lifetime | • Band saws – 2 years |
| • Bench vises – Lifetime | • Work stands – 2 years |
| • Positioning tables – Lifetime | • Arbor presses – 2 years |
| • Bench grinders, buffers and belt grinders – 3 years | • Milling machines – 2 years |
| • Tapping machines – 2 years | • Lathes – 2 years |
| • Drilling machines – 2 years | • Accessories – 1 year |

The obligation of Palmgren is limited solely to the repair or replacement, at our option, at its factory or authorized repair agent of any part that should prove deficient. Purchaser must lubricate and maintain the product under normal operating conditions at all times. Prior to operation become familiar with product and the included materials, i.e. warnings, cautions and manuals. **Failure to follow these instructions will void the warranty.**

This warranty is the purchaser's exclusive remedy against Palmgren for any deficiency in its products. Under no circumstances is Palmgren liable for any direct, indirect, incidental, special or consequential damages including lost profits in any way related to the use or inability to use our products. This warranty gives you specific legal rights which may vary from state to state.

SERVICE & REPAIR

1. If a Palmgren product requires a repair or warranty service **DO NOT** return the product to the place of purchase.
2. All warranty related work must be evaluated and approved by Palmgren/C.H. Hanson.
3. Prior to returning any item the user must obtain factory approval and a valid RGA number.
4. For instructions and RGA number call toll free (800) 827-3398.

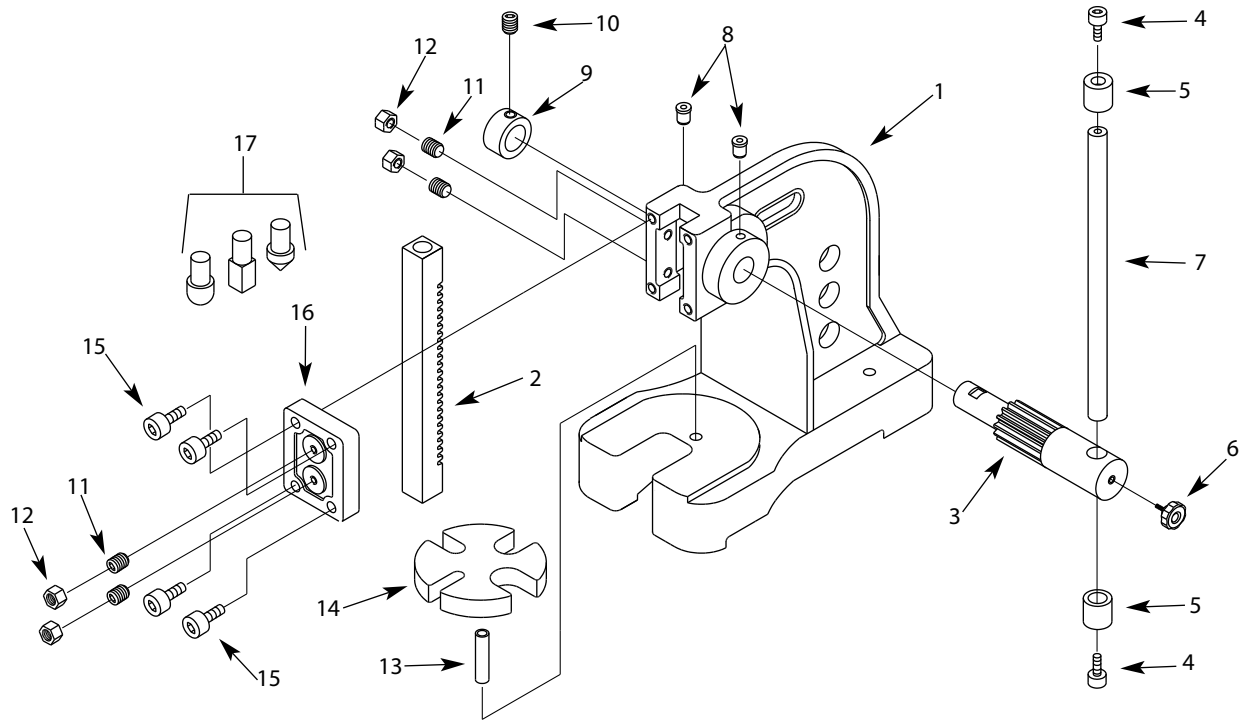

Figure 2 - Replacement Parts Illustration for 0.5-Ton, 2-Ton, 3-Ton and 4-Ton Arbor Press

REPLACEMENT PARTS LIST FOR ARBOR PRESS

Ref. No.	Description	Part Number for:				Qty.
		9661051C	9661201C	9661301C	9661401C	
1	Body	†	†	†	†	1
2	Ram with Magnet	9628701.00	9628714.00	9628727.00	9628738.00	1
3	Pinion	9628702.00	9628715.00	9628728.00	9628739.00	1
4	6-1.0 x 16mm Socket Head Bolt	*	-	-	-	2
4	6-1.0 x 20mm Socket Head Bolt	-	*	*	*	2
5	Cap	9628703.00	9628716.00	9628729.00	9628729.00	2
6	Knob	9628704.00	9628717.00	9628730.00	9628730.00	1
7	Handle	9628705.00	9628718.00	9628731.00	9628740.00	1
8	Oil Fitting	9628706.00	9628706.00	9628706.00	9628706.00	2
9	Pinion Retaining Ring	9628707.00	9628719.00	9628732.00	9628732.00	1
10	8-1.25 x 8mm Set Screw	*	*	*	*	1
11	6-1.0 x 20mm SetScrew	*	-	-	-	4
11	8-1.25 x 25mm Set Screw	-	*	*	*	4
12	6-1.0mm Hex Nut	*	-	-	-	4
12	8-1.25mm Hex Nut	-	*	*	*	4
13	Table Pin	9628708.00	9628708.00	9628708.00	9628708.00	1
14	Anvil	9628709.00	9628720.00	9628733.00	9628741.00	1
15	6-1.0 x 25mm Hex Head Bolt	*	-	-	-	4
15	8-1.25 x 30mm Hex Head Bolt	-	*	-	-	4
15	8-1.25 x 20mm Socket Head Bolt	-	-	*	*	4
16	Face Plate	9628710.00	9628721.00	9628734.00	9628742.00	1
17	Punch Set (3 pieces-round;point;square)	9628711.00	9628722.00	9628722.00	9628722.00	1
Δ	Depth Stop Collar Assembly	9635408.00	9635410.00	9635411.00	9635412.00	1
Δ	Operator's Manual	9637077.01	9637077.01	9637077.01	9637077.01	1

Δ Not Shown.

* Standard hardware item available locally.

† Not available as replacement part.