

USE AND CARE GUIDE

BREXLEY VANITY COMBO

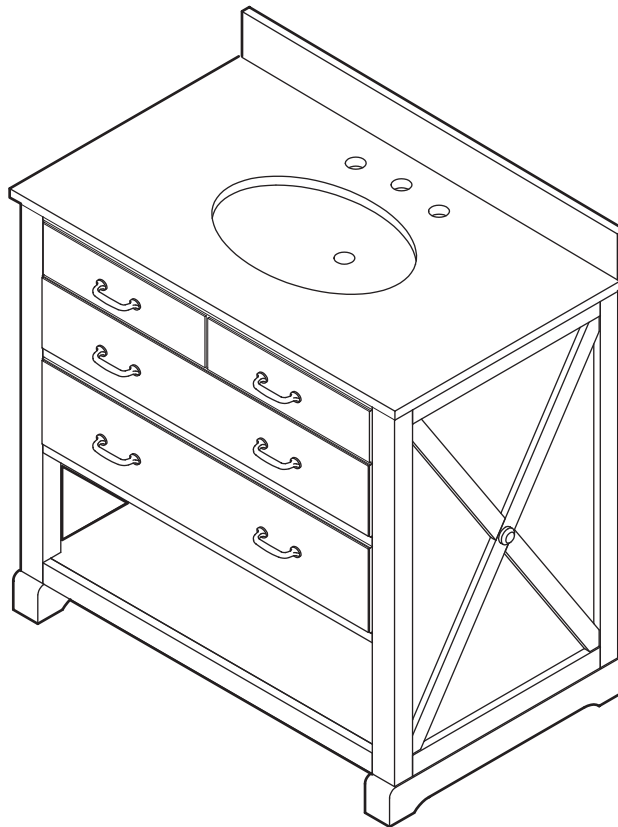

Questions, problems, missing parts? Before returning to the store,
call Home Decorators Collection Customer Service
8 a.m. - 6 p.m., EST, Monday-Friday

1-800-986-3460

HOMEDEPOT.COM/HDC

THANK YOU

We appreciate the trust and confidence you have placed in Home Decorators Collection through the purchase of this vanity. We strive to continually create quality products designed to enhance your home. Visit us online to see our full line of products available for your home improvement needs. Thank you for choosing Home Decorators Collection!

Table of Contents

Table of Contents.....	2	Assembly.....	4
Safety Information.....	2	Maintenance.....	5
Lifetime Limited Warranty.....	2	Care and Cleaning.....	5
Pre-Assembly.....	3		
Planning Assembly.....	3		
Tools Required.....	3		
Package Contents.....	3		

Safety Information



WARNING: Handle with care. Do not drop, handle roughly, or overtighten screws as this will cause damage to the wood.

NOTICE: Observe local plumbing and building codes.

Warranty

Home Decorators Collection products are manufactured with superior quality standards and workmanship and are backed by a 1-Year Manufacturer's warranty. Home Decorators Collection products are warranted to the original consumer purchaser to be free of defects in materials or workmanship. We will replace FREE OF CHARGE any product or parts that proves defective. Simply, return the product / part to any of The Home Depot retail locations or call 1-800-986-3460 to receive the replacement item. Proof of purchase (original sales receipt) from the original consumer purchaser must be made available for all Home Decorators Collection warranty claims.

This warranty excludes incidental/inconsequential damages and failures due to misuse, abuse or normal wear and tear. This warranty excludes all industrial, commercial & business usage, whose purchasers are hereby, extended a five year limited warranty from the date of purchase, with all other terms of this warranty applying except the duration of warranty.

Some states and provinces do not allow the exclusion or limitation of incidental or consequential damages, so the above limitations may not apply to you. This warranty gives you specific legal rights and you may also have other rights that vary from state to state and province to province. Please see a store or contact 1-800-986-3460 for more details.

Pre-Assembly

TOOLS REQUIRED

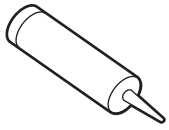

Silicone
sealant



Clean
rag

PACKAGE CONTENTS

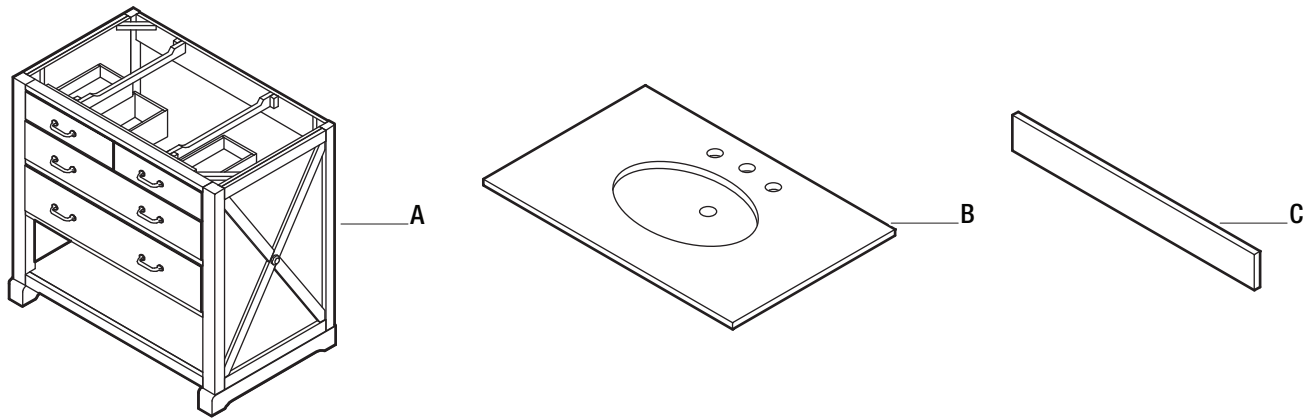

Part	Description	Quantity
A	Vanity	1
B	Top	1
C	Backsplash	1

Assembly

1 Applying the silicone

- Wipe off the top edges of the vanity (A) that will be in contact with the top using a clean rag.
- Apply a layer of silicone along all of the top edges.

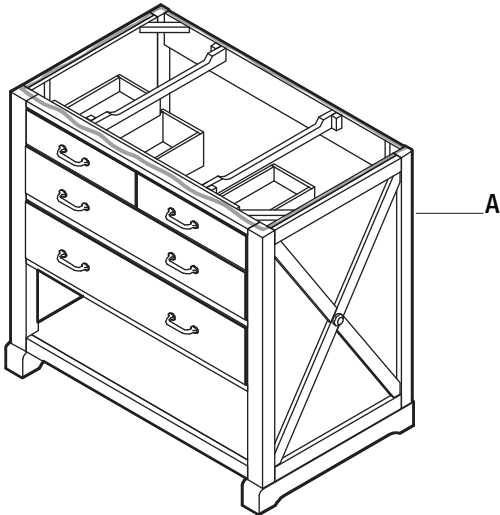

2 Installing the top



CAUTION: Two people are needed to safely lift the top and accurately position it onto the vanity.

- Align the top (B) with the vanity (A).
- Slowly lower the top (B) onto the vanity (A).

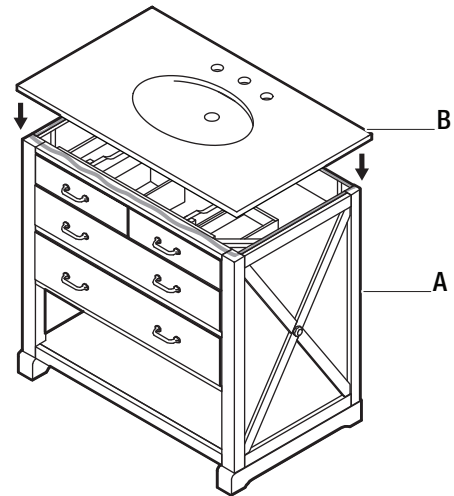

3 Installing the backsplash (optional)

- Wipe off the area of the top (B) where the backsplash (C) will sit using a clean rag.
- Apply a line of silicone onto the top (B) along the back edge.
- Align the backsplash (C) with the back edge. Slowly lower it onto the top (B) and gently press to adhere.
- Wipe away any seeping silicone from underneath the backsplash (C) with a clean rag.

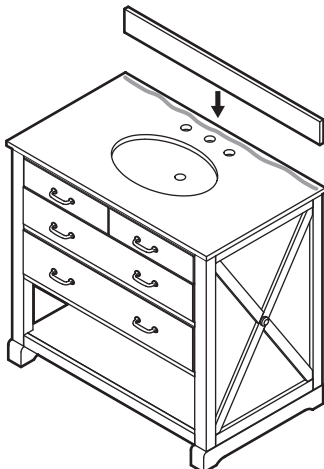

4 Removing the drawers (optional)

- Fully extend the drawer.
- Pull the two latches outward on the underside of the drawer to release the lock.
- Simultaneously tilt and lift the drawer upwards to pull it out of the vanity (A).

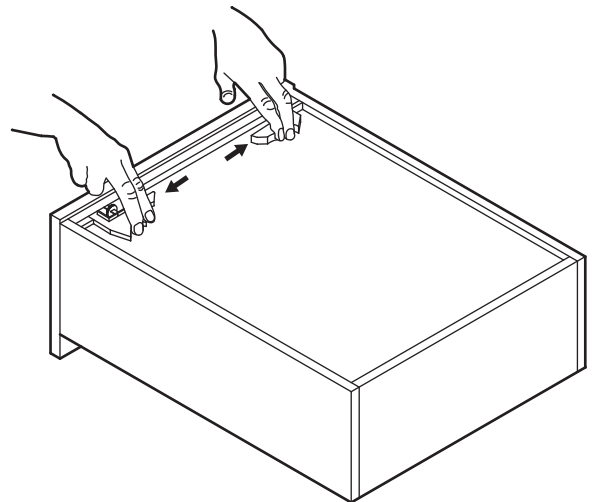

Maintenance

To protect your bath furniture, we suggest the following:

- Avoid placing your furniture in direct sunlight, as sunlight causes fading.
- Clean up spills immediately. Use a blotting rather than a wiping action. Water left over a long period of time will cause white spots in the finish.
- Alcohol, perfume, after-shave and medications can cause severe damage to the finish.

Care and Cleaning

For best results in cleaning and polishing your bath furniture, we recommend the following:

- Dust frequently with a clean, soft, dry, lint-free cloth. Clean the surface by rubbing in the direction of the grain.
- Polish your furniture approximately every six months with a product that contains detergents, emulsifiers and mineral oil. The detergents clean dirt from the furniture; the emulsifiers give it body to clean and last longer; the mineral oil is left behind as a barrier for dirt and moisture that can harm the finish. There is no grit to harm the finish, no wax build-up, and no silicone to raise the sheen and act as a barrier for touch-ups and refinishing.
- Clean up spills immediately. Use a blotting rather than a wiping action. Water left over a long period of time will cause white spots in the finish.
- Clean the outside surface with mild soap, warm water, and a soft cloth.
- On stubborn stains, use a powdered detergent and damp sponge or nylon scouring pad.
- Never use abrasive scouring powders, cleansers, or pads because they will scratch, damage, and dull the surface.
- Clean the sink surface with mild soap and warm water, then dry with a soft cloth.

HOME DECORATORS COLLECTION

Questions, problems, missing parts? Before returning to the store,
call Home Decorators Collection Customer Service
8 a.m. - 6 p.m., EST, Monday-Friday

1-800-986-3460

HOMEDEPOT.COM/HDC

Retain this manual for future use.